

Remote Emergency Pack for LED Luminaires YH25B Series standard version

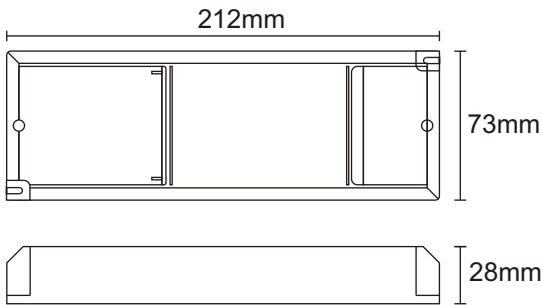

Dimension



Product description

- LED emergency converter that can transfer standard LED fitting into emergency LED fitting.
- Used with Lithium iron phosphate battery.
- Suits for LED fitting with external led driver.
- Accessory: test switch and charge indicator.

Applications

- Use in damp and dry environment.
- For use on a wide range of LED fittings to convert them from standard to emergency fitting.
- LED fitting would be maintained emergency fitting if standard (main powered) driver, emergency lighting kit and battery are all retained in the circuit. LED fitting would be non-maintained emergency fitting if only emergency conversion module and battery are retained in the circuit.
- Additional Relay that can control standard LED driver.
- Deep discharge protection.
- Connector between emergency kit and battery has the function of polarity reversal protection.
- Ambient range ta 0....50°C
- IP20 protection, relies on end-product enclosure for protection against accidental contact live parts.
- Not intended for use in luminaires for high-risk task area lighting.

Relevant standard

IEC 61347-1
IEC 61347-2-7
EN 55015
EN 61547
EN 61000-3-2
EN 61000-3-3
EN 62493
AS/NZS 60598-2-22
AS2293.3



Ordering data

Model No.:	Input voltage	Output voltage/power (Emergency mode)	Battery pack	Duration (E.M mode)
YH25B-2031050Li	220-240Vac 50-60Hz	10-50Vdc 2W cp	LiFePO4 6.4V 1.5Ah	180minutes
YH25B-3031050Li	220-240Vac 50-60Hz	10-50Vdc 3W cp	LiFePO4 6.4V 2.2Ah	180minutes
YH25B-3021050Li	220-240Vac 50-60Hz	10-50Vdc 3W cp	LiFePO4 6.4V 1.5Ah	120minutes
YH25B-5021050Li	220-240Vac 50-60Hz	10-50Vdc 5W cp	LiFePO4 6.4V 2.2Ah	120minutes
YH25B-4151050Li	220-240Vac 50-60Hz	10-50Vdc 4W cp	LiFePO4 6.4V 1.5Ah	90minutes
YH25B-6151050Li	220-240Vac 50-60Hz	10-50Vdc 6W cp	LiFePO4 6.4V 2.2Ah	90minutes
YH25B-6011050Li	220-240Vac 50-60Hz	10-50Vdc 6W cp	LiFePO4 6.4V 1.5Ah	60minutes
YH25B-8011050Li	220-240Vac 50-60Hz	10-50Vdc 8W cp	LiFePO4 6.4V 2.2Ah	60minutes

*YH25B / standard version

*CP: Constant power

Remote Emergency Pack for LED Luminaires YH25B Series standard version

Technical data

- Input rated voltage: 220-240V AC, 50-60Hz
- AC input current: 50mA max
- AC Input power rated 4.0 W max
- Power factor: >0.5
- Charge time : 16 hours
- Charge mode: trickle re-charging on battery.
- Output emergency power 2,8 wattage DC10...50V (3-15 LEDs) constant power output.
- Output voltage DC10...50V, DC55V max(SELV)
- Battery capacity (LiFePO4) 1500mAh, 2200mAh
- Battery Charging Current: 0-250mA
- 1, 1.5, 2, 3 hours rated duration
- Max. casing temperature tc 70°C
- Lumen Factor: 120lm/Wattage
- Reinforced insulation between mian supply and the battery circuit.
- This unit can recharge the battery normally after reconnecting of battery.

Battery information

Technical data(battery cells)

Battery model	IFR18650-1500	IFR18500-1100
Battery voltage per cell	3.2V	3.2V
Battery capacity per cell	1500mAh	1100mAh
Battery case temperature	0...60°	0...60°
Max short term temperature	70°	70°

Technical data(battery pack)

Model No.:	Rated	Type	Number of cells	Battery cells type
YHBL-2-1.5B	6.4V 1.5AH 9.6Wh	IFR18650-1500 2s1p	2	IFR18650-1500
YHBL-2-2.2	6.4V 2.2AH 14.08Wh	IFR18500-1100 2s2p	4	IFR18500-1100

*2S1P

S: Series connection

P: Parallel connection

Notes.

If users would like to change the batteries pack, please use the nominated models of STREAMER , then it will be under the warranty .

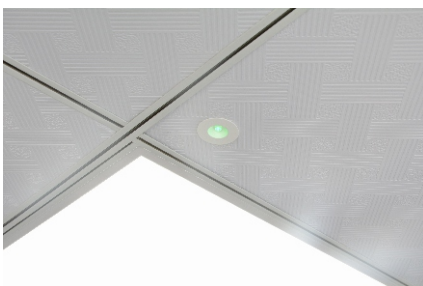
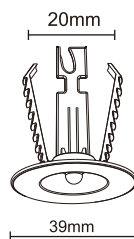

Fig.1



LED Holder



Fig.1 -Please make a 20mm cutting hole on the ceiling , where you could install the LED holder .

LED indicator

	Green stable: battery charging and fully charged
	Green off, DC mode (battery operation, emergency mode)

Remote Emergency Pack for LED Luminaires YH25B Series standard version

Notes :

Please do not cover this control gear .



Warranty

- Warranty 3 years
- Except for the following circumstances:
 - 1) Improper installation or operation.
 - 2) Misuse.
 - 3) Abuse.
 - 4) Unauthorized or improper repair alteration.
 - 5) Accident or negligence in use, storage, transportation.
 - 6) Any natural acts.

* If users would like to change the batteries pack, please use the nominated models of STREAMER , then it will be under the warranty .