

NP12180M (VRLA AGM BATTERY)

12V 18Ah



Neutron Power NP series are designed with AGM (Absorbent Glass Mat) technology and for general-purpose applications, such as UPS, telecom, and electrical utilities. These batteries are comply to most popular international standards, such as IEC60896-21/22, BS6290-4, Eurobat Guide. The battery container and cover are available both in V0 class flame retardant ABS or HBO ABS plastics too.

Neutron Power batteries meet the standards JIS, DIN, IEC60896-21/22 & BS6290-4. We have obtained ISO9001 & ISO14001 certification, UL approval (MH46127) and CE approval for all types of batteries. All these render our batteries to be compatible with requirements of world-level equipments.

Performance Characteristics		
General Information	Length	181mm (7.13 Inch)
	Width	77mm (3.03 Inch)
	Height	167mm (6.57 Inch)
	Total Height	167mm (6.57 Inch)
	Approx Weight	5.3 Kg
	Nominal Voltage	12 Volt
	Number of Cells	6
	Nominal Capacity (20 hour rate)	18 Ah
	Design float life expectancy under normal operation conditions at 25°C	3 ~ 5 Years
	Terminal	T1
	Casing Material	Standard (ABS)
Optional - V0 Class Flame Retardant (ABS)		
Nominal Capacity 77°F (25°C)	20 hour rate (0.90A, 10.5V)	18 AH
	10 hour rate (1.73A, 10.5V)	17.3 AH
	5 hour rate (3.24A, 10.5V)	16.2 AH
	1 hour rate (10.85A, 10.5V)	10.85 AH
Internal Resistance	Fully Charged Battery 77°F (25°C) ≤ 16 mOhms	
Self Discharge	3% of capacity declined per month at 20°C (average)	
Operating Temperature Range	Discharge	-20 ~ 60°C
	Charge	-10 ~ 60°C
	Storage	-20 ~ 60°C
Max. Discharge 77°F (25°C)	225A (5s)	
Short Circuit Current	850A	
Charge Methods	Constant Voltage Charge 77°F (25°C)	
	Cycle use 2.40 - 2.45VPC	
	Standby use 2.20 - 2.30VPC	
	Temperature compensation -20mV/°C	
	Maximum charging current 5.4A	
Battery Certification	 MH46127 UL CERTIFIED - MH46127	

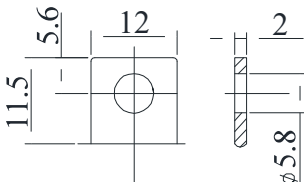
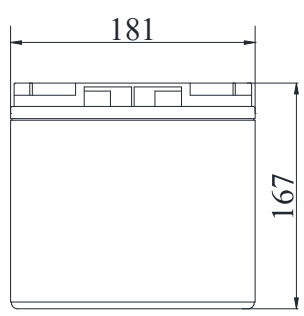
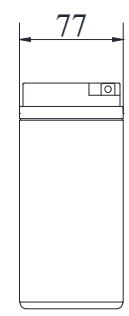
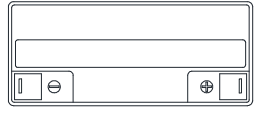
Outer Dimension		
Terminal T1 		
		

* The above characteristics data are average values obtained within three charge/discharge cycles not the minimum value. Neutron Power reserves the rights update the data information without prior notice.

Constant Current Discharge Data (Amperes at 25°C)									
F.V/Time	5Min	10Min	15Min	30Min	1Hr	3Hr	5Hr	10Hr	20Hr
1.60V/Cell	79.87	43.89	35.90	21.28	11.27	5.00	3.368	1.800	0.936
1.67V/Cell	73.73	41.71	34.78	20.40	11.15	4.95	3.332	1.781	0.926
1.70V/Cell	66.97	38.45	32.22	19.32	11.04	4.90	3.296	1.762	0.916
1.75V/Cell	61.44	36.27	30.51	18.58	10.85	4.81	3.239	1.732	0.900
1.80V/Cell	60.31	35.60	28.98	18.24	10.65	4.73	3.180	1.700	0.883

Constant Power Discharge Data (Watts per cell at 25°C)									
F.V/Time	5Min	10Min	15Min	30Min	1Hr	2Hr	3Hr	4Hr	5Hr
1.60V/Cell	155.76	85.58	67.26	41.49	21.99	12.71	9.76	8.01	6.57
1.67V/Cell	143.77	81.34	63.93	39.79	21.75	12.57	9.66	7.93	6.50
1.70V/Cell	130.59	74.97	58.92	37.68	21.52	12.44	9.55	7.84	6.43
1.75V/Cell	119.81	70.73	55.59	36.24	21.15	12.22	9.39	7.71	6.32
1.80V/Cell	117.61	69.43	54.57	35.57	20.76	12.00	9.21	7.57	6.20

