

LED UNDERGROUND LIGHT

ITEM NO. : LUL-W30A Series

INSTRUCTION OF LED UNDERGROUND LIGHT/LUL-W30A

The products are widely used in the decorative lighting for piazza, restaurants, private villas, garden, conference room, exhibition hall, beautify the area environment, stage bar, shopping mall, parking sculpture, the tourist attractions.

A. Specification

A-1. Structure

Material: Aluminum Alloy
 Input Voltage: 120V/240V AC or 24V DC
 Protection: IP67
 Work temperature: -20°C-40°C



LUL-W30A-60

A-2. Model Configuration Table

Model No.	LED Color	LED Quantity	Power Consumption	Size	Weight	✓
LUL-W30A-30	R/G/B / WW / W / NW	30pcs SMD/5050	7 WATTS	L500xW30xH70mm	1.9kg±5%	
LUL-W30A-60	R/G/B / WW / W / NW	60pcs SMD/5050	15 WATTS	L1000xW30xH70mm	3.8kg±5%	

Seamless splicing technology on the lamp body, it only reserves 0.5 ~ 1.0mm gap among two lamps for later maintenance.

B. Photometrics Parameters

LUL-W30A -60

B-1. Cadela distribution

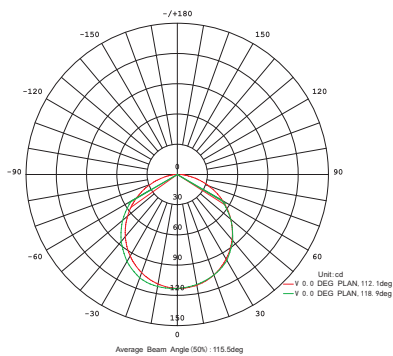

WW

B-2. Illuminance at a distance

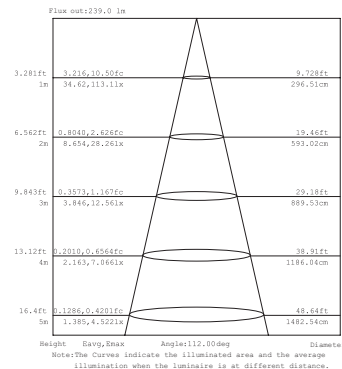

WW

C. Dimension drawing

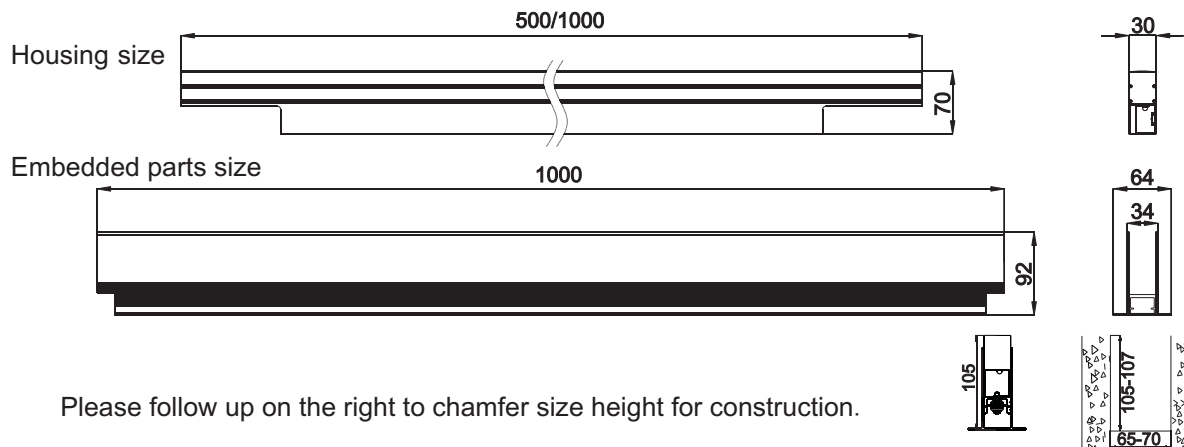

Please follow up on the right to chamfer size height for construction.

LED UNDERGROUND LIGHT

ITEM NO. : LUL-W30A Series

D. Installation

D-1. Fix embedded parts

As picture showed below, screws the fixed floor of embedded parts on the ground by M4 self-tapping screws, then put embedded parts on it and after adjusting well ,tighten the M5 screws by spanner.

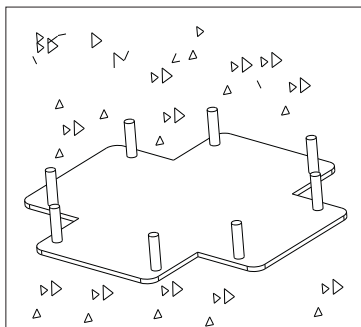
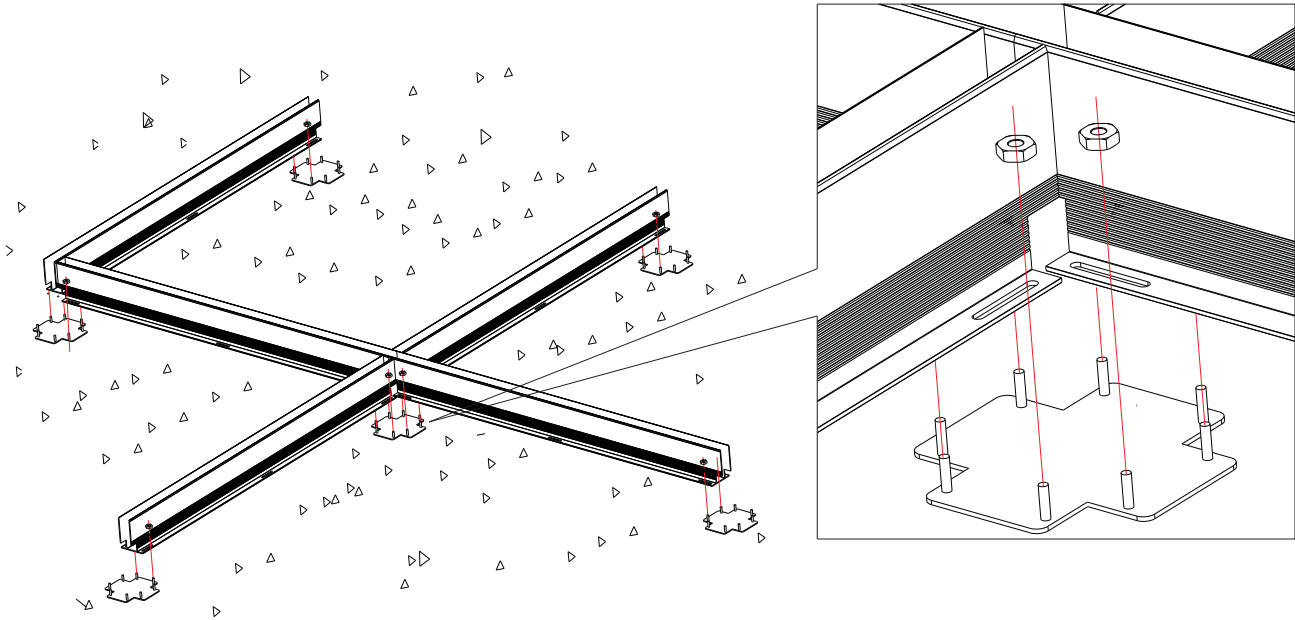

Screw the embedded part by M4 self-tapping screws.

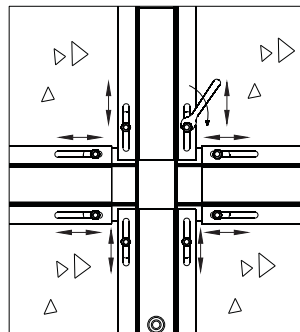

Put embedded parts on it well and after adjusting , tighten the M5 screws by spanner.

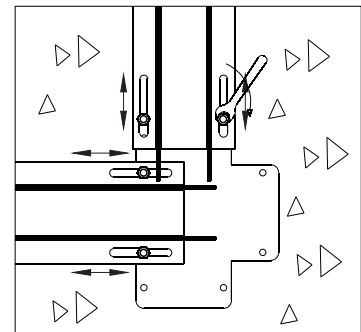

D-2. Place plastic filler

Place plastic filler in embedded part.

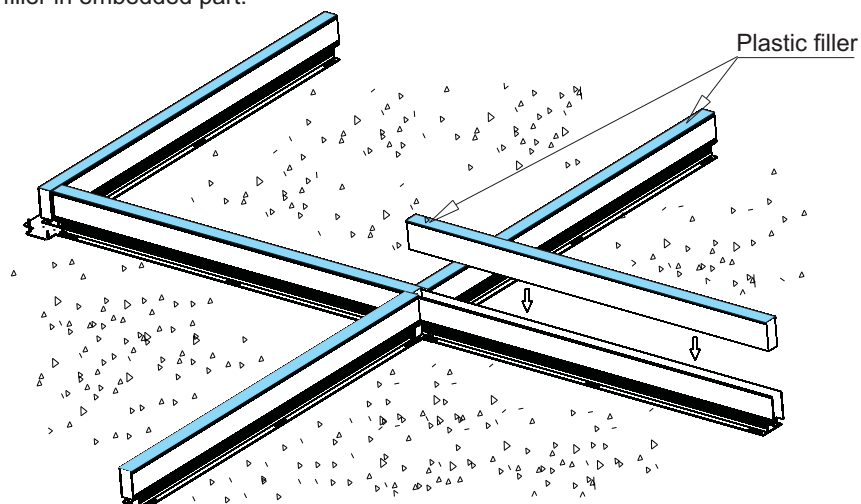

LED UNDERGROUND LIGHT

ITEM NO. : LUL-W30A Series

D-3. Pouring concrete around the embedded part, take out the plastic filler after concrete condensing.

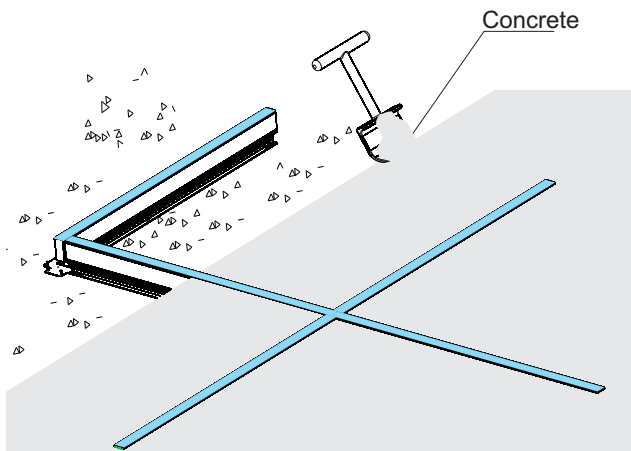

Pour concrete

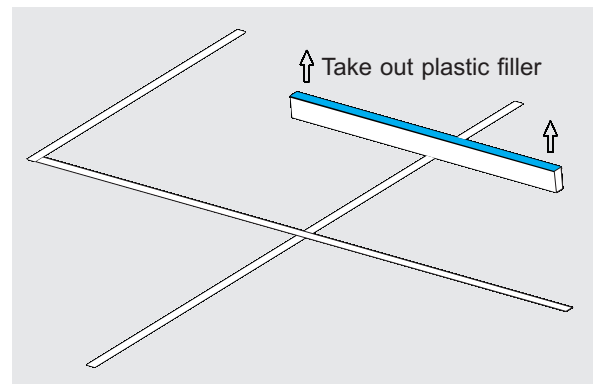

Take out filler

D-4. Connect lamps first (refer to "connection" for detailed connection way), then put lamps in embedded part

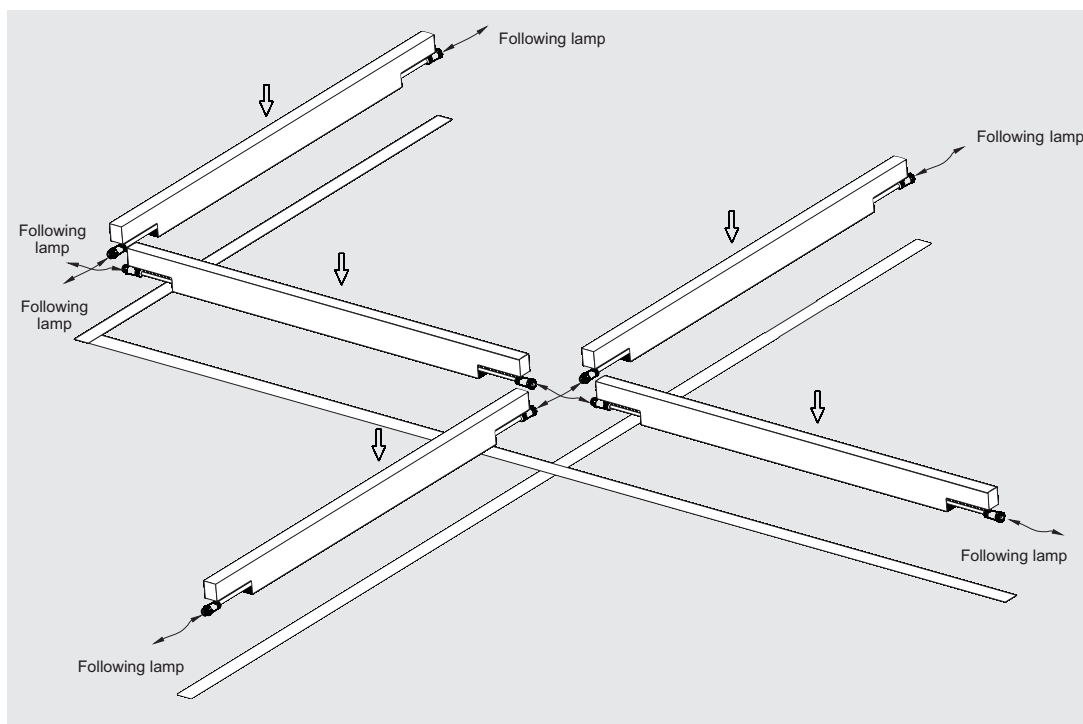

D-5. Put the special handle in the gap of two lamps body and hand the lamp, then drag it out.

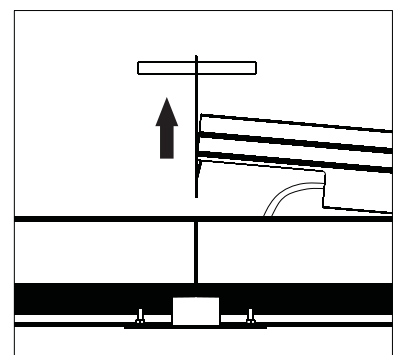
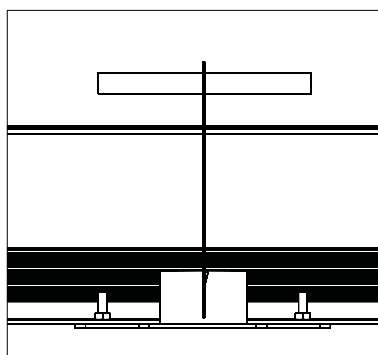
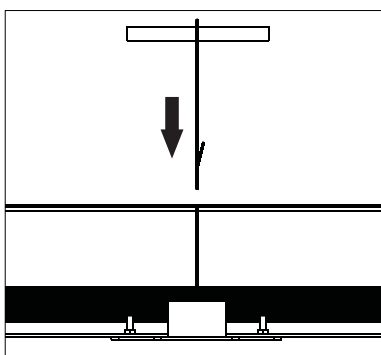

LED UNDERGROUD LIGHT

ITEM NO. : LUL-W30A Series

E. Connection(maximum 8 pcs can be connected for each sections)

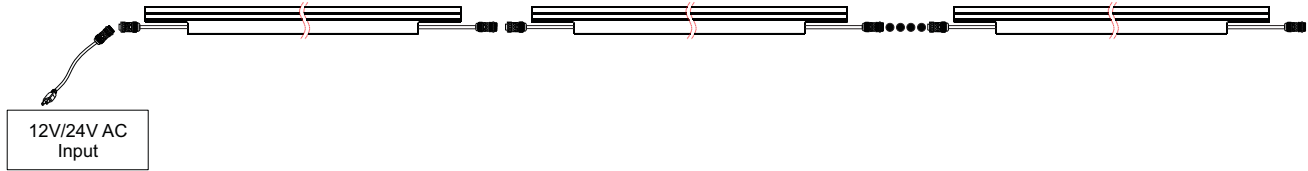

Caution:

1. Do not plug them into power when the product is still in package;
2. Don't use anything to cover the fixture during application;
3. Don't use this product in close environment;
4. If this product appears to be damaged, do not attempt any repair, please contact your dealer.

Warning:

- * Neglect on action of the above treatment will lead to failure of waterproof and proper working of the lights!!!
- * Make sure the ground connection well avoid electric shock, due to metal housing.