

LED UNDERGROUND LIGHT

ITEM NO.: LUL - GM4/5

INSTRUCTION OF LED UNDERGROUND LIGHT/LUL-GM4/5

The product are widely used in the decorative lighting for piazza, restaurants, private villas, garden, conference room, exhibition hall, beautify the area environment,stage bar,shopping mall,parkingsculpture,the tourist attractions.

A. Specification

A-1. Structure

Materials of Shell: 304 stainless steel+aluminum housing

Power Factor: >0.97

Power Efficiency: >90%

Input Voltage: DC12V/DC24V

Protecting Rate: IP67

Operating Temperature: -20°C~50°C



LUL-GM4



LUL-GM5



A-2. Model Configuration Table

Model No.	LED Color	Input Voltage	LED QTY	Powe consumptionr	Beam angle	Size	Weight	✓
LUL-GM4	WW / W / NW	24V DC	3SMD 1W	3 WATTS	35° / 45°	L195xW63xH65mm	1.2kg±5%	
LUL-GM5	WW / W / NW	24V DC	6SMD 1W	7 WATTS	35° / 45°	L328xW63xH65mm	1.4kg±5%	

B.Photometrics Parameters

B-1. Distribution Curve

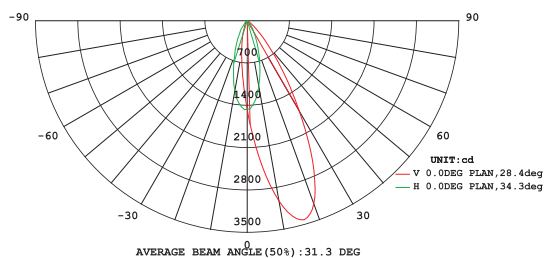

LUL-GM4 Beam angle: 35°

B-2.Illuminance at a distance

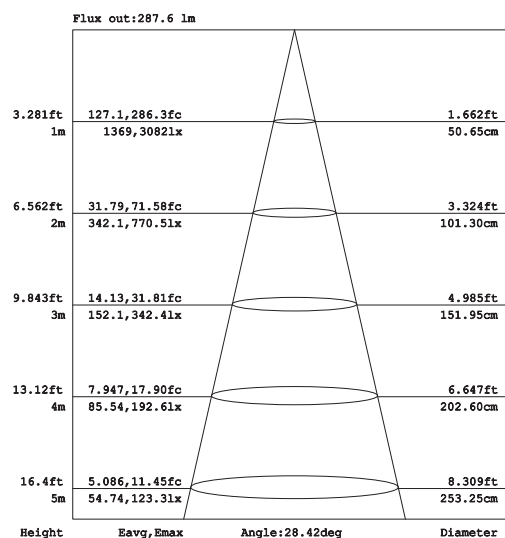

Note:The Curves indicate the illuminated area and the average illumination when the luminaire is at different distance.

LED UNDERGROUND LIGHT

ITEM NO.: LUL - GM4/5

C. Dimension drawing

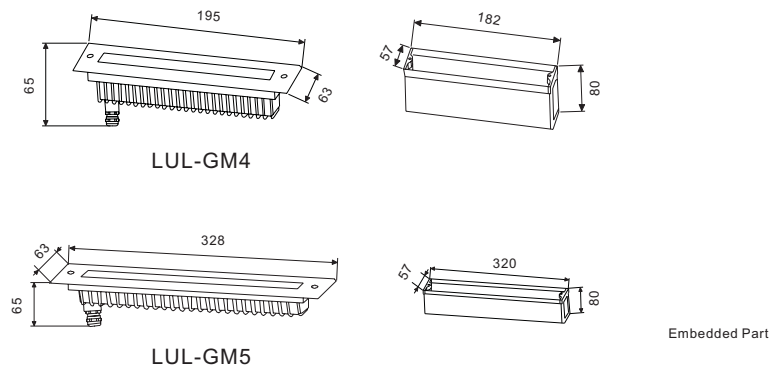

D. Installation and Connection

D-1. Installation Steps

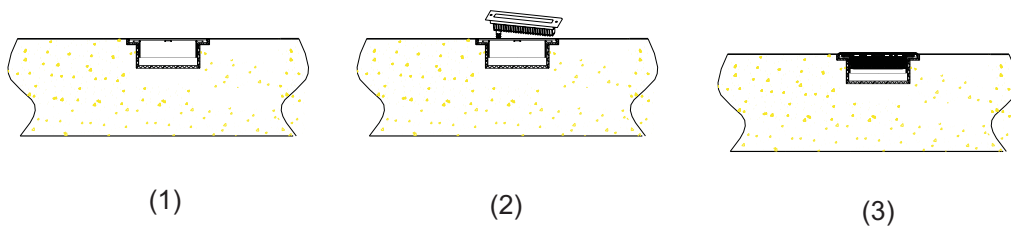

1. Make holes in the installation place according to embedded part, pls note:
Every light has supporting sheet which is used for protecting embedded part well because of pressure of cement or other heavy (like picture shown)
2. Power the light well according to the voltage of light(24VDC) and make waterproof treatment well.
3. Put light into embedded part and screw them well;

D-2. Connection

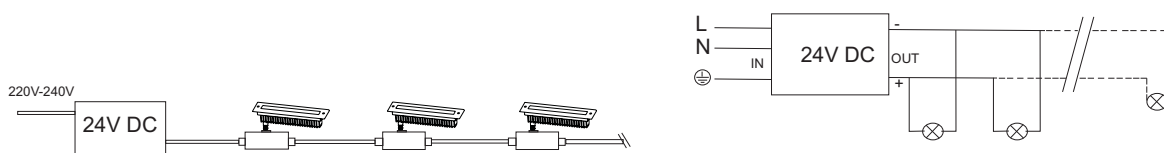

E. Waterproof treatment (don't put joint part in water)

The wire joint must be sealed with a 20mm thermal shrinking tube, blow and shrink it with a hair driers; thence wrapped with waterproof tape (auto-adhesive, please refer to below instruction for operation) on both side; Blow the second 25mm shrink tube at last so as to protect waterproof tape under sunshine and guarantee the waterproof validity. For detailed instruction pls refer to below picture:

LED UNDERGROUND LIGHT

ITEM NO.: LUL - GM4/5

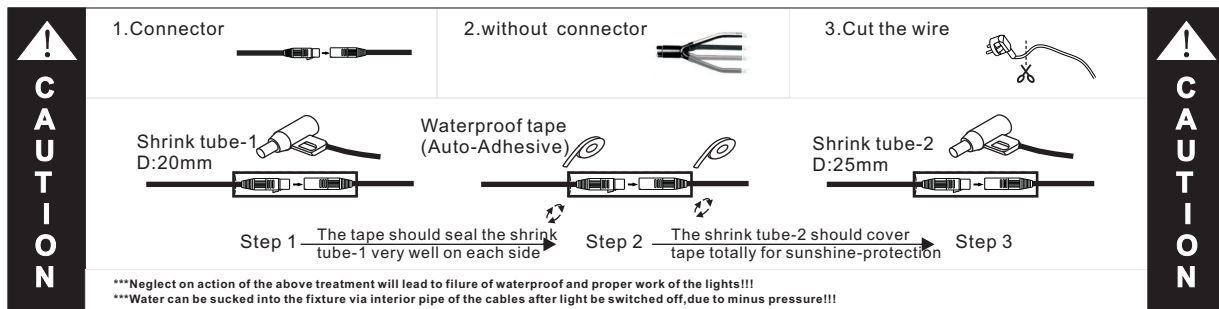

*** Power connector should be treated in the same way if available!!!

*** IP68 connector does not require above treatment, but you connect a threaded twist quite well to prevent operational errors lead to joint water

Caution:

- 1.Only professional people to make installation,pls check the fixture well before installation;
- 2.Pls install the lights according to this datasheet carefully, screw the light well and connect the wire correctly.

Warning:

- * neglect on action of the above treatment will lead to failure of waterproof and proper working of the lights!!
- * Make sure the ground connection well avoid electric shock, due to metal housing.

Note: The above instruction are subject to update or improved without notice.Pls turn to our staff for further details !
Thanks for your long term support !