

LM100

Medium Intensity Obstruction Light



Products description and application

LM100 series medium intensity aviation obstruction light Type B has been awarded the FAA, ICAO, CAAC certification.

Medium intensity type B is used to mark the constructions for aircraft warning at night. Red at night and steady burning /flashing working mode. Combined with advantages of advanced LED, optics and system control technology to satisfied the harshest applications.

Applying to the air traffic warning areas such as towers(Telecom, GSM), smokestacks (heat-engine plant, coking plant chemical plant etc.), buildings, port devise, construction machinery, wind power generator etc.

Applying to the 45-90m obstacle or on 45m -90m position of big obstacle.

Applying to outside environment.

Applying to high salt area.



Features

- o Die-cast aluminum housing, surface electrostatic powder sprayed yellow,
- o LED light source, lifespan up to 100000h.
- o Three-profiteering design(Waterproof, shockproof, dust proof)
- o Use UV resistant, shock resistant PC lampshade.
- o Switchable work mode:steady burning /flashing (support field configuration)
- o With fault alarm inspection and fault alarm output. (Normally on/off optional)
- o Professional EMC design, Anti-electromagnetic interference.
- o Professional optical design
- o Lightning protection up to 10kv
- o Optional GPS function

General Specifications

International standard	CAAC ICAO FAA	MH6012-2015 ICAO Annex 14 Volume I 6th Edition Advisory Circular 150/5345-43H	Aviation obstruction light Airport design and operation Specification for Obstruction Lighting Equipment
------------------------	---------------------	--	---

Electrical parameters		Mechanical structure parameters	
Operation voltage	AC230V±10%	Main material	Aluminium alloy
Working power frequency	50Hz~60Hz	Cover material	Merlon(PC)
Power rating	65W	UV resistant rate	UL746C(f1)
Power consumption	30W(40times/min)	Operating humidity	0%~95%RHP
Lightning protection	MH6012-2015 L- L 6kV MH6012-2015 L-G 6kV MH6012-2015 air discharge8kV MH6012-2015 Contact discharge 6kV	Operating temperature	Ta-40 °C ~ +60 °C
EMC	MH6012-2015	IP Rate	IP66
		Entry cable	Side M20X1.5 ,Suitable cable diameter 9-14mm Bottom M20X1.5, Suitable cable diameter 9-14mm
		Base Color	Yellow●
		Weight	6.5 kg

Optical parameters			
Light-emitting component	LED	Intensity	2000cd±25%
Light color	Red (white can be	Operating mode	20/30/40/60 FPM,

LM100

Medium Intensity Obstruction Light



Vertical degree customized)
 $\geq 3^\circ$

Horizontal degree

Steady burning; Default 40FPM
 Plane 360°

Mounting dimensions

Unit:mm

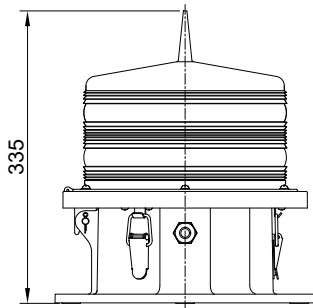
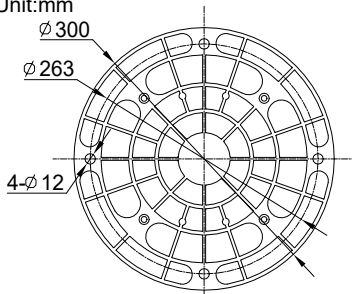

picture 1 regular base size(Side outlet)

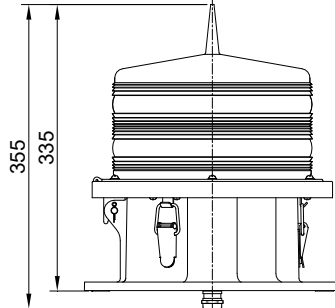
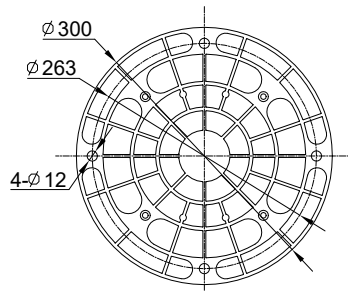

picture 2 regular base size(Bottom outlet)

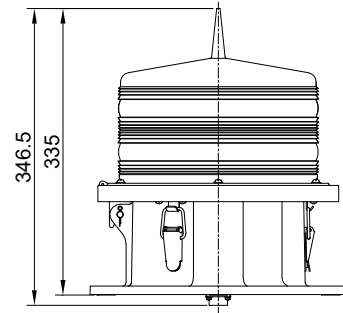
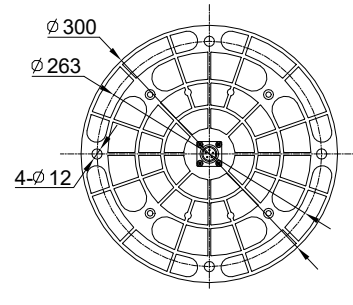

picture 3 regular base size(Bottom aero plug)

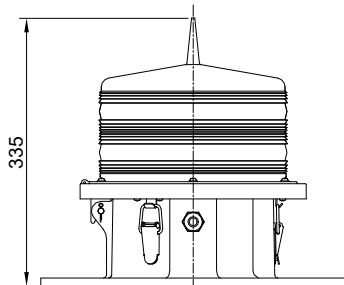
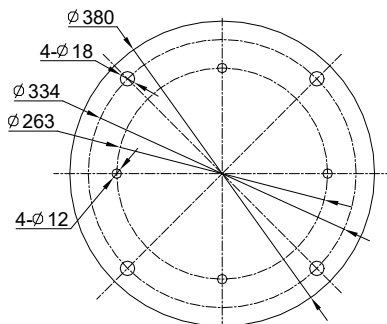

picture 4 big base size(Side outlet)

Wiring diagram

LM100

Medium Intensity Obstruction Light

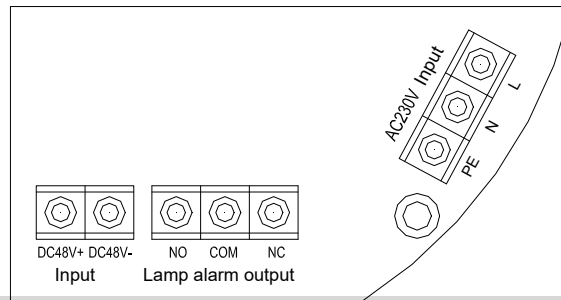

Installation method of use

- Make sure the light on a smooth surface which has enough strength, if there is no mounting surface, we can customize special mounting bracket as request.
- Open the 3 hasps on the bottom, turn around the light, Exposed terminal row.
- Access the power cord from the waterproof joint, Correctly connect the power signal wire and the ground wire according to the terminal definition on the label.
- After finishing the connection, fasten the buckles. Check whether the power cables are connected correctly before power on.
- GPS synchronization test should be in the outdoor environment without any block. Synchronization takes about 15 minutes (Only suit for the type of synchronization with GPS).

Lightdial switch function using the method

- The product with flash work mode manual adjustable function, also with fault alarm function.
- Method for flash work mode: disconnect the power supply, take apart the light and dial the switch with screwdriver.

Dial code	0 0 0	0 0 1	0 1 0	1 0 1
Dial sample figure				
Light work mode	steady burning(auto) (steady burning at night)	Flash(auto) 20times/min	Flash(auto) 30times/min	Flash(auto) 30times/min
Dial code	0 1 1	1 0 0	1 1 0	1 1 1
Dial sample figure				
Light work mode	flash 40times/Min	Flash 60times/min	Manual steady	Manual off

Remarks 1: when turnover to number end is 1, Turnover to ON is 0.

Remarks 2: auto steady burning function means that the light could see whether it is daytime or night, when it is night, it would be steady burning.

Remarks 3: Manual steady burning function means that the light would see whether it is night or not, it tacitly confirm that it is steady burning all the time.

Remarks 4: Manual steady off function means that turning off the light all the time for test.

Remarks 5: No matter how in any mode, it would have 1 second for itself examination when connecting to the electricity.

UTC Time Control Function(East Australia)

Winter time: 17:00~22:59 eastern time: the aviation lights work

Summer time: 18:00~23:59 eastern time: the aviation lights work

Fault alarm function

LM100

Medium Intensity Obstruction Light



When the light don't connect the power supply or the work current for light is low: relay has no action, "COM" and "Normal Close" terminals closed, as shown.

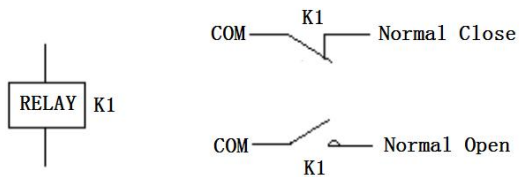

When the light connect the power supply and work normally: the relay work, "COM" and "Normal Open" terminals closed, as shown.

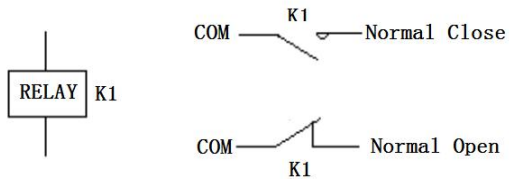

- If need to receive the "disconnection" signal when no power supply connection or fault, alarm signal wire should connect at "COM" + "Normal Open" Terminal;
- If need to receive the "closed" signal when no power supply connection or fault, alarm signal wire should connect at "COM" + "Normal Close" terminal.

Precautions

- The part of material of products is PC(like lamp cover and lamp shell), so it cannot direct or indirect touch the organic solvent, such as industrial alcohol, banana oil, isotropic alcohol, carbon tetra-chloride, cyclone and so on, otherwise, the product will be corrosion.
- Ensure that the power connection part is correct before using.
- Temperature rise when light working is normal phenomenon.
- Please do not open any components except professional serviceman.