

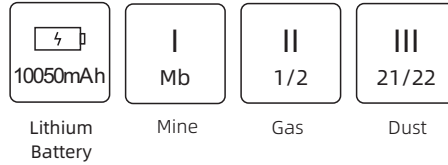

ExMP52R

Explosion Proof Rechargeable LED Handlamp



Description

- Suitable for explosive environment class I, class II zone 1, 2, class III zone 21, 22 and other professional portable lighting.
- Intrinsically safe explosion-proof design.
- The body is made of permanent anti-static, anti-aging and anti-corrosion high-strength alloy plastic injection molding, compact and lightweight, easy to carry.
- Professional optical lens design, soft illumination, uniform spot, in line with GB30734 fire protection standard.

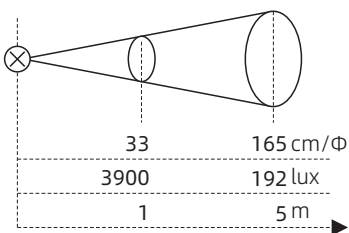

Parameters

Certifications:	IECEX, ATEX
Ex mark:	IECEX: Ex ib I Mb; Ex ib IIC T4 Gb; Ex ib IIIB T130°C Db ATEX: Ex I M2 Ex ib I Mb Ex II 2 G D Ex ib IIC T4 Gb; Ex ib IIIB T130°C Db
Usage:	I, II Zone 1/2, and II Zone 21/22
Working ambient temp.:	-40°C ≤ Ta ≤ +55°C
Ingress protection:	IP66/67
CCT:	6500K
Luminous flux:	≥330lm (strong mode), ≥170lm (work mode)
Run time:	≥17h (strong mode), ≥24h (work mode)
Battery type:	lithium Battery (IEC 61233, IEC 61960)
Battery capacity:	3.6V, 10050mAh
Charging way:	matched 1000/01-B52 charging base
Charging time:	<14h
Charging cycles:	500 cycles
Lifespan:	50,000h (without battery)
Position indicator:	Blue / Green / Yellow / Red / White (optional)

Note: The luminous flux and continuous discharge time are the values measured under the environment of -20°C ≤ Ta ≤ +55°C.

Features



Order specifications

Illustration	Description	Weight (g)	Order No.
	Explosion Proof Rechargeable LED Handlamp	589	ExMP52R-□
	Explosion Proof Rechargeable LED Handlamp + Charging base	962	ExMP52R-□+B52-□

0-Without ● R-Red ● G-Green
 ● Y-Yellow ● B-Blue ○ W-white

□ GB ○ EN □ BS □ ANSI □ AS □ JIS

Position indicator

Code of plug

Note: Users can choose type B integrated charging track rail and integrated charging stand. Please see pages 04 and 05 for details.

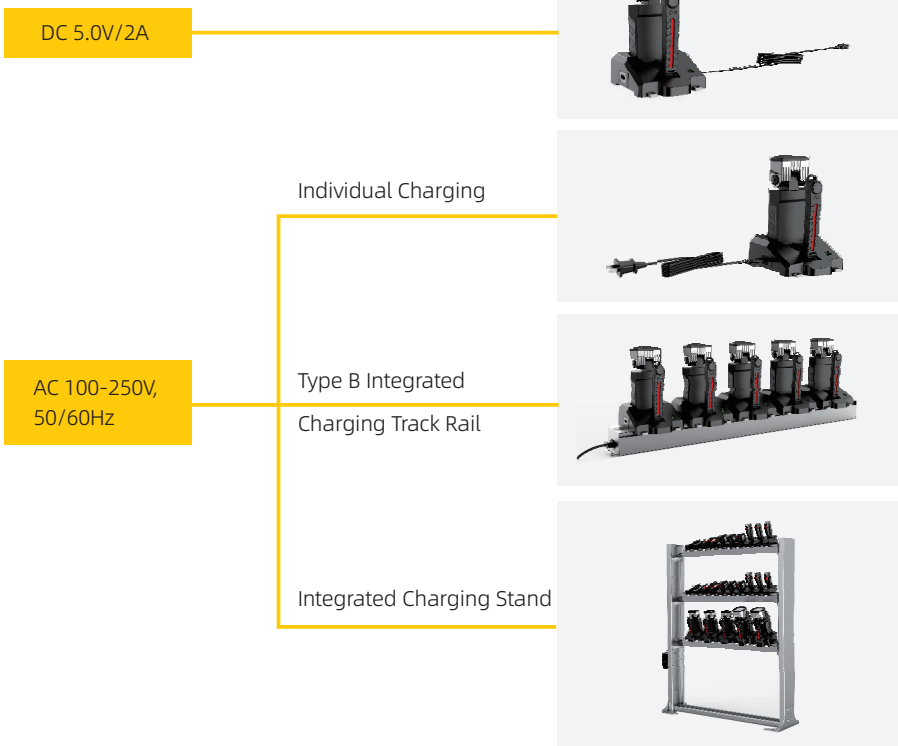

Charging system

- ExMP52R is equipped with a special charging base to ensure safe use. The charging base has a charging indicator light, red means charging, green means fully charged.
- The charging base has 3 charging ports - AC 100-250V/2A, DC 5.0V/2A and a matched integrated charging port at the bottom. Safe, simple and convenient.
- This product is suitable for type B integrated charging track rail.

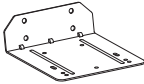
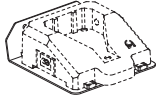
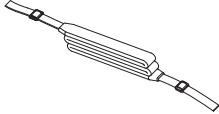
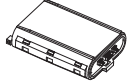

Note: For technical parameters of integrated charging track rail and integrated charging stand, please refer to pages 04 and 05.

Spare parts

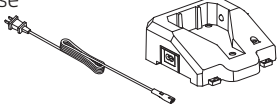
Illustration	Description	Weight (g)	Order No.
	 304 stainless steel	435	1000/11-03-01
	/	30	1000/11-02-01
	3.6V, 10050mAh	158	1000/05-R52-Ex
	Input voltage/current: DC 5.0V/2000mA	94	1000/12-01
	Input voltage/current: AC 100-250V/500mA Input voltage/current: DC 5.0V/2000mA	373	1000/01-B52-□

 GB
  EN
  BS
  ANSI
  AS
  JIS
 _____ Code of plug

Outline dimension (unit: mm)

