

# EMERGENCY EXIT LIGHTS SLIMLINE

SMT LED with lifespan 50,000 burning hours  
SMT LED surface mount emergency exit light



● **SLS.M.SRE.NC180.WLF**

Running-man graphical exit signs  
comply to latest SS 563 & SS 508

● **SLS.M.SE.NC180.WLF**

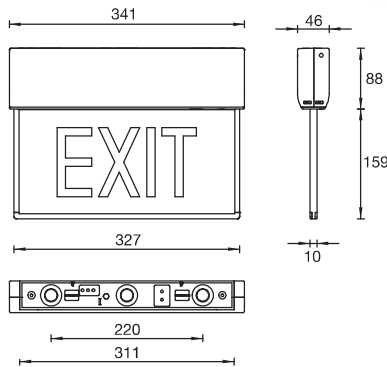

Dimension: mm NTS

## TECHNICAL DATA

Mode of Operation	: Maintained
Lamp	: 1.5W SMT LED
Rated Duration	: 3 hrs and others
Mains Supply	: 230 Volts, 50/60Hz
Power Consumption	: < 3W
Battery	: High temp Nickel Cadmium/Lithium
Charge Monitor	: Green LED (normal) / Red LED (error)
Test Facility	: Tactile switch
Safety Feature	: Low volt cut-off preventing battery overdischarge
Fitting Construction	: Injection moulded fire retardant acrylonitrile butadiene styrene (ABS)
Diffuser	: Fire retardant moulded acrylic
Mounting	: Wall or ceiling
Cable Entry	: Ø20mm K/O hole
Weight	: 1.0kg (gross)
Compliance	: SS 563 : Part 1 & 2, SS IEC 60598-2-22
Warranty	: 1 year

## KEY FEATURES

- > Using Surface Mount Technology LED
- > High Durability & Reliability
- > Low Heat
- > Low Maintenance
- > Low Power Consumption
- > No "Black Ends"
- > Self Testing Function
- > Malfunction Indicator
- > Versatile & User Customisable



Type and batch tested with  
PSB PLS-LISTED LABEL

Surface Mount  
Internal Lit  
LED Slim Exit Sign



## ORDERING GUIDE (Please check with Sales Dept if customisation is required)

Single Sided	Double Sided	Legend
SLS.M.SE.NC180.WLF	SLS.M.DE.NC180.WLF	
SLS.M.SEE.NC180.WLF	SLS.M.DEE.NC180.WLF	
SLS.M.SEW.NC180.WLF	SLS.M.DEE.NC180.WLF	
SLS.M.SR.NC180.WLF	SLS.M.DR.NC180.WLF	
SLS.M.SRE.NC180.WLF	SLS.M.DRE.NC180.WLF	
SLS.M.SRW.NC180.WLF	SLS.M.DRE.NC180.WLF	
SLS.M.SRS.NC180.WLF		
SLS.M.SRN.NC180.WLF		