

## Model EC-25 (CMDA and CMSA Applications) 25.2 (360) K-factor Upright Sprinkler Extended Coverage

### IMPORTANT

Refer to Technical Data Sheet TFP2300 for warnings pertaining to regulatory and health information.

Always refer to Technical Data Sheet TFP700 for the "INSTALLER WARNING" that provides cautions with respect to handling and installation of sprinkler systems and components. Improper handling and installation can permanently damage a sprinkler system or its components and cause the sprinkler to fail to operate in a fire situation or cause it to operate prematurely.

Scan the QR code or enter the URL in a web browser to access the most up-to-date electronic version of this document. Data rates may apply.



[docs.jci.com/tycofire/TFP213](http://docs.jci.com/tycofire/TFP213)

### General Description

The TYCO Model EC-25, Extended Coverage 25.2K Upright Sprinkler is a UL Listed, standard response, extended coverage Control Mode Density Area (CMDA) sprinkler for storage and non-storage applications in accordance with the design requirements of NFPA 13.

The Model EC-25 sprinkler may also be used as a Control Mode Specific Application (CMSA) sprinkler in accordance with the Alternative Sprinkler Systems Design chapter in NFPA 13.

The Model EC-25 sprinkler is also FM Approved as a quick response, extended coverage sprinkler for storage and non-storage applications in accordance with FM Global Data Sheets.

The Model EC-25 sprinkler complies with the requirements in NFPA 13 for the protection of storage and display in retail stores.

When used in accordance with National Fire Protection Association (NFPA) 13, smoke vents and draft curtains are not required as specified in the 2015 edition of the International Building Code (IBC) and International Fire Code (IFC) for CMSA sprinklers with an RTI of 50 or less and a design of 12 or fewer sprinklers.

These sprinklers offer a maximum coverage area of 196 ft<sup>2</sup> (18,2 m<sup>2</sup>), which is almost double the area offered by standard coverage sprinklers used for similar applications.

For more information on applications and benefits of the Model EC-25 Upright Sprinkler, refer to the available White Papers at [www.tyco-fire.com](http://www.tyco-fire.com).

### NOTICE

The Model EC-25 Upright Sprinklers described herein must be installed and maintained in compliance with this document, as well as with the applicable standards of the NFPA, in addition to the standards of any other authorities having jurisdiction. Failure to do so may impair the performance of these devices.

The owner is responsible for maintaining their fire protection system and devices in proper operating condition. Contact the installing contractor or sprinkler manufacturer with any questions.



### Sprinkler Identification Number (SIN)

Refer to Table A for sprinkler identification number.

### Technical Data

#### Approvals

- UL and C-UL Listed: CMDA (Standard Response)
- FM Approved: CMDA and CMSA (Quick Response)
- EAC Approved

**Note:** Approvals only apply to the service conditions indicated in the Design Criteria section.

#### Finish

Natural Brass

#### Physical Characteristics

Frame	Brass
Deflector	Copper
Compression Screw	Stainless Steel
Hook	MONEL
Strut	MONEL
Link Assembly	Solder, Nickel
Button	Brass
Sealing Assembly	Beryllium Nickel w/TEFLON
Ejection Spring	INCONEL
Deflector Nut	Brass

#### Response Time Index (RTI)

Less than or equal to 50 (m-s)<sup>0.5</sup>

#### Additional Technical Data

See Table A

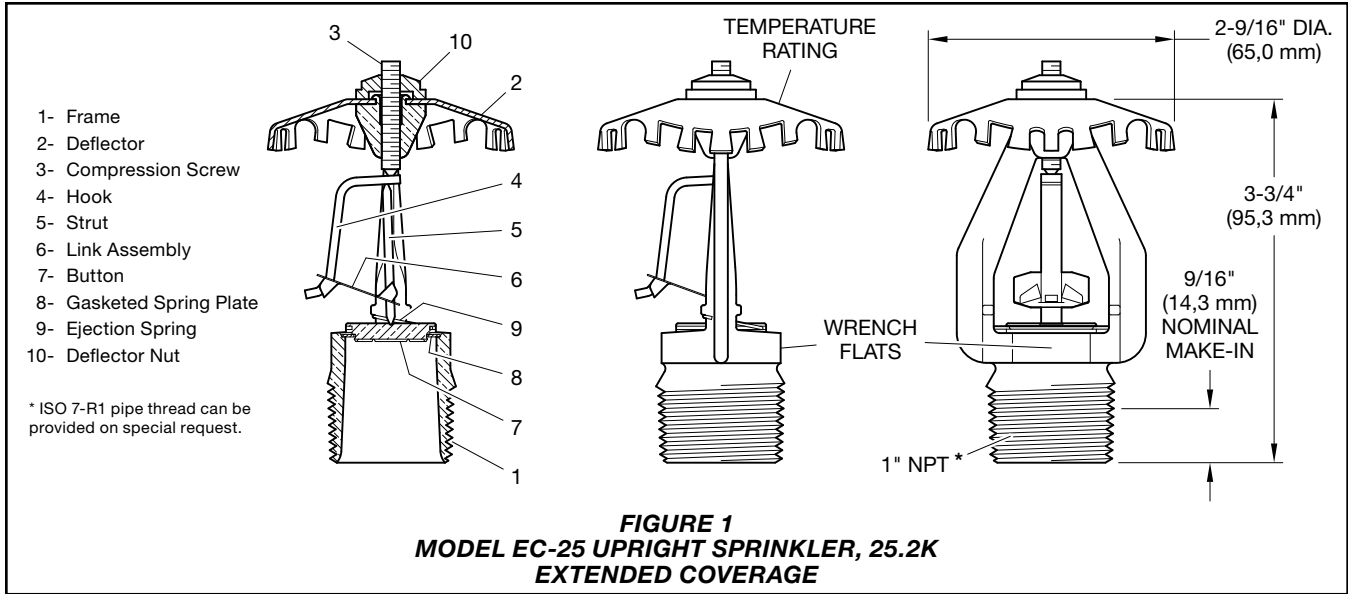

## Operation

The fusible link assembly is comprised of two link halves that are joined together by a thin layer of solder. When the rated temperature is reached, the solder melts and the two link halves separate, allowing the sprinkler to activate and flow water.

## Design Criteria

The following general guidelines provided for the TYCO Model EC-25 Upright Sprinklers can be used for a quick reference. The National Fire Protection Association (NFPA) and FM Global (FM Approvals) provide installation standards that must be used to properly design an automatic sprinkler system utilizing Model EC-25 Upright Sprinklers. The guidelines provided by NFPA and FM Global may differ. Consequently, the appropriate standard must be used for a given installation.

General guidelines are not intended to provide complete installation criteria. In all cases, the appropriate NFPA or FM Global installation standard must be referenced to ensure applicability and to obtain complete installation guidelines. For more information, see Table B.

Item	Description
Sprinkler Identification Number (SIN)	TY9128
K-factor (gpm/psi) (lpm/bar)	25.2 gpm/psi <sup>1/2</sup> (362,9 lpm/bar <sup>1/2</sup> )
Temperature Rating °F (°C)	165°F (74°C) 212°F (100°C)
Thread Size	1 in. NPT or ISO 7-R 1
Sprinkler Orientation	Upright
Maximum Working Pressure, psi (bar)	175 psi (12,1 bar)

**TABLE A**  
**MODEL EC-25 UPRIGHT SPRINKLER**  
**TECHNICAL DATA**

### Specific Application Design Criteria – Alternative System Design (CMSA)

The TYCO Model EC-25 Extended Coverage Upright Sprinklers (TY9128) have successfully undergone large-scale fire tests at FM Global to comply with the current edition of NFPA 13. As such, NFPA 13 may be utilized for design options with the Model EC-25 Upright Sprinklers for providing ceiling-only protection.

This allows for the protection of Palletized, Single, Double, and Multiple Row Open Racks. Protection is up to 30 ft (9,1 m) of Cartoned, Unexpanded Group A Plastic Commodities in a maximum 35 ft (11 m) ceiling condition with extended spacing up to 196 ft<sup>2</sup> (18,2 m<sup>2</sup>). This protection is delivered

while maintaining very reasonable flow and pressure requirements. Pipe sizes as well as water supply requirements can now be kept to a minimum when compared to other design methods for high piled storage challenges.

When used in accordance with NFPA 13, smoke vents and draft curtains are not required as specified in the 2015 edition of the International Building Code (IBC) and International Fire Code (IFC) for CMSA sprinklers with an RTI of 50 or less and a design of 12 or fewer sprinklers.

Guidelines for the use of the Tyco Model EC-25 Upright Sprinkler in accordance with the Alternative System Design (CMSA) are shown in Table B.

Storage Type	NFPA	NFPA	FM Global
Sprinkler Type	CMDA	CMSA <sup>4</sup>	Storage and Non-Storage
Response Type	Standard Response	Quick Response	Quick Response
System Type	Wet/Dry/ Preaction	Wet	Wet
Temperature Rating °F (°C)	165°F (74°C) 212°F (100°C) <sup>1</sup>	165°F (74°C) 212°F (100°C)	165°F (74°C) 212°F (100°C)
Roof Construction	Unobstructed and Noncombustible Obstructed <sup>3</sup>	In accordance with Chapter 21 (2013, 2016 ed.) or Chapter 24 (2019, 2022 ed.) of NFPA 13 for Extended Coverage Sprinklers	Refer to FM 2-0
Ceiling Slope	Refer to NFPA 13	Refer to NFPA 13	Refer to FM 2-0
Maximum Coverage Area	196 ft <sup>2</sup> (18,2 m <sup>2</sup> )	196 ft <sup>2</sup> (18,2 m <sup>2</sup> )	Refer to FM 2-0
Minimum Coverage Area	Refer to NFPA 13	100 ft <sup>2</sup> (9,3 m <sup>2</sup> )	Refer to FM 2-0
Maximum Spacing	14 ft (4,3 m) where coverage area exceeds 144 ft <sup>2</sup> (13,5 m <sup>2</sup> ) 15 ft (4,6 m) where coverage area is 144 ft <sup>2</sup> (13,5 m <sup>2</sup> ) or less	14 ft (4,3 m)	Refer to FM 2-0
Minimum Spacing	8 ft (2,4 m)	10 ft (3,0 m)	Refer to FM 2-0
Minimum Clearance to Commodity	3 ft (900 mm) <sup>2</sup>	Refer to NFPA 13	Refer to FM 2-0
Sprinkler Distance to Ceiling	Refer to NFPA 13	Refer to NFPA 13	Refer to FM 2-0
Open Frame (that is, no solid shelves), Single, Double, Multiple-Row, or Portable Rack Storage of Class I-IV and Cartoned Nonexpanded Plastics	Refer to NFPA 13	In accordance with Chapter 21 (2013, 2016 ed.) or Chapter 24 (2019, 2022 ed.) of NFPA 13 for Extended Coverage Sprinklers	Refer to FM 2-0 and 8-9
Solid Pile or Palletized Storage of Class I-IV and Cartoned Nonexpanded Plastics	Refer to NFPA 13	N/A	Refer to FM 2-0 and 8-9
Storage and Display of Class I-IV and cartoned nonexpanded Group A plastics and nonexpanded exposed Group A plastics in Retail Stores	In accordance with Chapter 20 (2007, 2010, 2013, 2016, ed.), Chapter 23 (2019 ed.), or Chapter 26 (2022 ed.) of NFPA 13 for Extended Coverage Sprinklers	N/A	N/A
Idle Pallet Storage	N/A	N/A	Refer to FM 2-0, 8-9, and 8-24
Rubber Tire Storage	N/A	N/A	Refer to FM 2-0 and 8-3
Roll Paper Storage (Refer to the Standard)	N/A	N/A	Refer to FM 8-21
Flammable/Ignitable Liquid Storage (Refer to the Standard)	N/A	N/A	Refer to FM 7-29
Aerosol Storage (Refer to the Standard)	N/A	N/A	Refer to FM 7-31
Automotive Components in Portable Racks (Control mode only; refer to the Standard)	Refer to NFPA 13	N/A	N/A

**Notes**

1. The cULus Listing for the sprinkler permits design criteria for high temperature CMDA sprinklers to be used with ordinary and intermediate temperature Model EC-25 sprinklers.
  2. A minimum operating pressure of 22 psi (1,5 bar) is required for clearances less than 4 ft (1,2 m).
  3. Model EC-25 Sprinklers, having been specifically tested and Listed for non-combustible obstructed construction, are suitable for use within trusses or bar joists having non-combustible web members greater than 1 in. (25,4 mm) when applying the 4 times obstruction criteria rule defined under "Obstructions to Sprinkler Discharge Pattern Development."
  4. CMSA criteria is based on the original FM Approval for the Model EC-25 Sprinkler, which is now included in Chapter 21 (2103, 2016 ed.) and Chapter 24 (2019, 2022 ed.) of NFPA 13. Additional design criteria for the Model EC-25 Sprinkler may be found in FM Global Property Loss Prevention Data Sheet 8-9. The Model EC-25 Sprinkler is described as a quick response K25.2 EC upright storage sprinkler in FM Global Data Sheet 8-9.
- N/A = Not Applicable

**TABLE B**  
**MODEL EC-25 UPRIGHT SPRINKLER**  
**COMMODITY SELECTION AND DESIGN CRITERIA OVERVIEW**

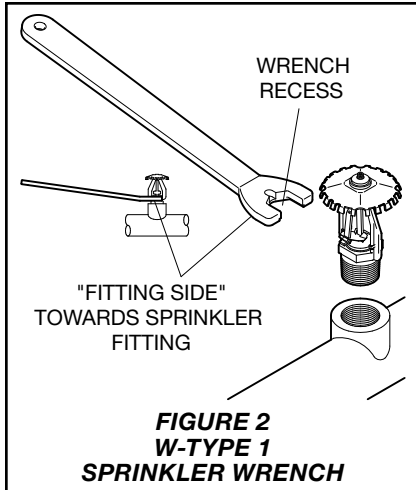

## Installation

The TYCO Model EC-25 Extended Coverage 25.2K Upright Sprinklers are to be installed in accordance with this section.

Damage to the fusible link assembly during installation can be avoided by handling the sprinkler using only the frame arms and the appropriate sprinkler wrench. Do not grip or apply any force to the fusible link assembly. Damaged sprinklers must be replaced immediately.

A leak-tight 1 in. NPT sprinkler joint should be obtained by applying a minimum-to-maximum torque of 20 to 30 lb-ft (26,8 to 40,2 N-m). Higher levels of torque may distort the sprinkler inlet with consequent leakage or impairment of the sprinkler.

**Note:** Install the Model EC-25 Upright Sprinkler in the upright position.

**Step 1.** With pipe thread sealant applied, hand-tighten the sprinkler into the sprinkler fitting. Do not apply any force to the link assembly, and handle the Model EC-25 Upright Sprinkler only by the frame arms.

**Step 2.** Wrench-tighten the Model EC-25 Upright Sprinkler using only the W-Type 1 Sprinkler Wrench, see Figure 2, and by fully engaging (seating) the wrench on the sprinkler wrench flats.

**Step 3.** After installation, inspect the link assembly for damage. In particular, verify that the link assembly and hook are positioned as illustrated in Figure 1, and that the link assembly has not been bent, creased, or forced out of its normal position in any way. Damaged sprinklers must be replaced immediately.

## Care and Maintenance

The TYCO Model EC-25 Extended Coverage 25.2K Upright Sprinklers must be maintained and serviced in accordance with this section.

Before closing a fire protection system main control valve for maintenance work on the fire protection system that it controls, obtain permission to shut down the affected fire protection system from the proper authorities and notify all personnel who may be affected by this decision.

Inspection, testing, and maintenance must be performed as indicated below and in accordance with the local requirements and/or national codes. Any impairment must be immediately corrected.

The owner is responsible for the inspection, testing, and maintenance of their fire protection system and devices in compliance with this document, as well as with the applicable standards of any authorities having jurisdiction. Contact the installing contractor or product manufacturer with any questions.

Automatic sprinkler systems are recommended to be inspected, tested, and maintained by a qualified Inspection Service in accordance with local requirements and/or national codes.

## Limited Warranty

For warranty terms and conditions, visit [www.tyco-fire.com](http://www.tyco-fire.com).

## Ordering Procedure

Contact your local distributor for availability. When placing an order, indicate the full product description and part number (P/N).

### Sprinkler Assemblies

Specify: Model EC-25 Extended Coverage 25.2K Upright Sprinklers (TY9128), (specify temperature rating), with Natural Brass finish, P/N (specify):

165°F (74°C) . . . . . P/N 58-450-1-165  
212°F (100°C) . . . . . P/N 58-450-1-214

### Special Order

#### Sprinkler Assemblies with ISO 7-R 1 Thread Connection

Specify: Model EC-25 Extended Coverage 25.2K Upright Sprinklers (TY9128) with ISO 7-R 1 thread connection, (specify temperature rating), with Natural Brass finish, P/N (specify):

165°F (74°C) . . . . . P/N 58-451-1-165  
212°F (100°C) . . . . . P/N 58-451-1-214

### Sprinkler Wrench

Specify W-Type 1 Sprinkler Wrench, P/N 56-872-1-025



## TFP213 Change History Appendix

ISSUE DATE	NOTES
01-24	Page 3, Table B, Row 15 beginning Storage and Display, relocated criteria "In accordance with Chapter 20 (2007, 2010, 2013, 2016, ed.), Chapter 23 (2019 ed), or Chapter 26 (2022 ed.) of NFPA 13 for Extended Coverage Sprinklers" from NFPA CMSA column to NFPA CMDA column.
11-23	Page 1, Technical Data Approvals subsection, removed NYC Approved under MEA 355-01-E. All other changes, Page 3, Table B: Row beginning Storage Type Open Frame, column NFPA CMSA, updated criteria to "In accordance with Chapter 21 (2013, 2016 ed.) or Chapter 24 (2019, 2022 ed.) of NFPA 13 for Extended Coverage Sprinklers," formerly "In accordance with Chapter 20 (2007, 2010, 2013, 2016 ed.), Chapter 23 (2019 ed.), or Chapter 26 (2022 ed.) of NFPA 13 for Extended Coverage Sprinklers"; Row beginning Storage and Display, changed to "Storage and Display of Class I-IV and cartoned non-expanded Group A plastics and nonexpanded exposed Group A plastics in Retail Stores," formerly "Storage and Display of Class I-IV and Cartoned Nonexpanded Group A Plastics in Retail Stores"; Same row, column NFPA CMSA, updated criteria to "In accordance with Chapter 20 (2007, 2010, 2013, 2016, ed.), Chapter 23 (2019 ed), or Chapter 26 (2022 ed.) of NFPA 13 for Extended Coverage Sprinklers," formerly "N/A."
08-23	Page 1, General Description section, reorganized section to clarify separate conditions for UL Listed and FM Approved applications; Page 2, Design Criteria section, consolidated content previously spanning pages 2 to 4 and organized into three sub-sections, UL and C-UL Listing Criteria, FM Approval Criteria, and NFPA 13 – Alternative System Design (CMSA) Criteria, now replaced by general guidelines and a Specific Application Design Criteria – Alternative System Design (CMSA) sub-section; Page 3, Table B, Commodity Selection and Design Criteria Overview, separated NFPA criteria into two columns for CMDA and CMSA sprinkler applications, broadened FM Global column to encompass Storage and Non-Storage sprinkler applications, formerly CMDA/CMSA, added rows for each to provide Roof Construction, Ceiling Slope, Maximum and Minimum Coverage Areas and Spacing, Minimum Clearance to Commodity, and Sprinkler Distance to Ceiling, and added row restricting all from Storage and Display of Class I-IV and Cartoned Nonexpanded Group A Plastics in Retail Stores.
05-23	Page 4, Installation section, corrected step sequence numbering to Steps 1, 2, and 3, formerly shown as 1, 3, and 4 in 09-22 edition.
09-22	Page 1, added QR code and URL to allow convenient access to electronic version from printed document; Page 1, Approvals sub-section, added EAC Approved; Page 4, changed corporate address and telephone number to 1467 Elmwood Avenue, Cranston, RI 02910   Telephone +1-401-781-8220, formerly 1400 Pennbrook Parkway, Lansdale, PA 19446   Telephone +1-215-362-0700.
08-18	Updated Tyco® branding and document format; Added Johnson Controls copyright; Added disclaimer stating specifications and information subject to change without notice; Added reference to Regulatory and Health Warning Technical Data Sheet TFP2300.
05-18	Organized technical information into tables as required by UL.
02-18	Corrected typographical error in UL and C-UL Listing Criteria section, clearance between deflector and top of storage sub-paragraph to to ...clearances of 36 in. (0,9 m) up to 48 in. (1,21 m)..., formerly ...clearances of 36 in. (0,9 m) up to 8 in. (1,21 m)...
01-18	Clarified reference to NFPA 13 in descriptions of application and system design requirements; Removed design criteria Tables A and B.
04-15	Changed temperature rating to 212°F (100°C), formerly 214°F (101°C).
05-14	Clarified CMDA and CMSA applications; Clarified requirements per IBC and IFC.
12-13	Added new NFPA 13, 2013 Chapter 21 allowances for alternative system design. Information regarding storage and shelf storage of Class I - IV and cartoned non-expanded plastic commodities has been added.
06-12	Clarified applicable system types in UL and C-UL Listing Criteria and in FM Approval Criteria.

## UPDATING INSTRUCTIONS

Page 2 of 2

ISSUE DATE	NOTES
09-11	Added current enhancements to FM Global design criteria.
12-10	Removed patent information.
09-04	Added reference to Installer Warning data sheet TFP700.; Added UL and C-UL Listed installation criteria for non-combustible web members greater than 1 inch within trusses and or bar joists.
01-03	Added new Tyco Fire & Building Products masthead.
11-02	Page 1, General Description section, added statement EC-25 Sprinklers comply with the criterion for the protection of retail stores as described in the 2002 edition of NFPA 13, Section 12-7.2; Page 2, UL and C-UL Listing Criteria, revised minimum flow requirements to be based on design density applied over actual area of coverage per sprinkler and to provide examples, to add 36 in. (0,9 m) minimum clearance between deflector and top of storage, added high-piled storage occupancies criteria.
02-02	New Technical Data Sheet TFP213 describes Series EC-25 Extended Coverage Upright Sprinkler.