

Series LFII Residential Sprinklers 4.2 K-Factor Flush Pendent Wet Pipe and Dry Pipe Systems

General Description

The TYCO RAPID RESPONSE Series LFII Residential Flush Pendent Sprinklers (TY2284) are decorative, fast response, fusible solder sprinklers designed for use in residential occupancies such as homes, apartments, dormitories, and hotels. When enhanced flow characteristics for residential portions of any occupancy per NFPA 13 is the major consideration, the Series LFII Sprinklers should be the first choice.

The Series LFII Residential Sprinklers are intended for use in the following scenarios:

- wet and dry pipe residential sprinkler systems for one- and two-family dwellings and mobile homes per NFPA 13D
- wet and dry pipe residential sprinkler systems for residential occupancies up to and including four stories in height per NFPA 13R
- wet and dry pipe sprinkler systems for the residential portions of any occupancy per NFPA 13

Historically residential sprinklers, based on their Listing, have been limited to wet pipe sprinkler systems to assure speed of water delivery for a given prescribed design area (number of design sprinklers). The Listing for the

IMPORTANT

Always refer to Technical Data Sheet TFP700 for the "INSTALLER WARNING" that provides cautions with respect to handling and installation of sprinkler systems and components. Improper handling and installation can permanently damage a sprinkler system or its components and cause the sprinkler to fail to operate in a fire situation or cause it to operate prematurely.

Series LFII Residential Flush Pendent Sprinklers now offers the laboratory approved option of designing dry pipe residential sprinkler systems.

Through extensive testing, it has been determined that the number of design sprinklers (hydraulic design area) for the Series LFII Residential Sprinklers (TY2284) need not be increased over the number of design sprinklers (hydraulic design area) as specified for wet pipe sprinkler systems, as is customary for density/area sprinkler systems designed per NFPA 13.

Consequently, the Series LFII Residential Sprinklers (TY2284) offer the features of non-water filled pipe in addition to not having to increase the number of design sprinklers (hydraulic design area) for systems designed to NFPA 13, 13D, or 13R. Non-water filled pipe will permit options for areas sensitive to freezing.

These Sprinklers have a 4.2 (60,5) K-factor that provides the required residential flow rates at reduced pressures, enabling smaller pipe sizes and water supply requirements.

The flush design of the Series LFII Residential Sprinklers features a separable escutcheon providing 3/8 inch (9,5 mm) vertical adjustment. This adjustment reduces the accuracy to which the pipe nipples to the sprinklers must be cut.

The Series LFII Residential Sprinklers have been designed with heat sensitivity and water distribution characteristics proven to help in the control of residential fires and to improve the chance for occupants to escape or be evacuated.



NOTICE

The Series LFII Residential Flush Pendent Sprinklers (TY2284) described herein must be installed and maintained in compliance with this document and with the applicable standards of the National Fire Protection Association, in addition to the standards of any authorities having jurisdiction. Failure to do so may impair the performance of these devices.

Owners are responsible for maintaining their fire protection system and devices in proper operating condition. The installing contractor or sprinkler manufacturer should be contacted with any questions.

Model/Sprinkler Identification Number (SIN)

TY2284

Technical Data

Approvals

- UL Listed for use with wet pipe and dry pipe systems
- C-UL Listed for use only with wet pipe systems
- NYC Approved under MEA 44-03-E

Refer to the Design Criteria section for details on these approvals.

Maximum Working Pressure

175 psi (12,1 bar)

Discharge Coefficient

K= 4.2 GPM/psi^{1/2} (60,5 LPM/bar^{1/2})

Temperature Rating

162°F (72°C)

Vertical Adjustment

3/8 inch (9,5 mm)

Finishes

Sprinkler and Escutcheon: White, Chrome, Black, or Antique Brass

Physical Characteristics

BodyCopper Alloy
DeflectorCopper
Valve CapCopper Alloy
Orifice SealPTFE
Heat CollectorsCopper

Operation

The sprinkler assembly contains a small fusible solder element. When exposed to sufficient heat from a fire, the solder melts and enables the internal components of the sprinkler to fall away. At this point the sprinkler activates with the deflector dropping into its operated position (Figure 1C), permitting water to flow.

Design Criteria

The RAPID RESPONSE Series LFII Residential Flush Pendent Sprinklers (TY2284) are UL and C-UL Listed for installation in accordance with the following criteria.

Note: *When conditions exist that are outside the scope of the provided criteria, refer to the Residential Sprinkler Design Guide TFP490 for the manufacturer's recommendations that may be acceptable to any local authority having jurisdiction.*

System Types

Per the UL Listing, wet pipe and dry pipe systems may be utilized. Per the C-UL Listing, only wet pipe systems may be utilized.

For dry systems, corrosion-resistant or internally galvanized pipe shall be utilized with the sprinklers described in this data sheet

For dry systems not using CPVC, pendent sprinklers shall be installed on return bends, where the sprinklers, return bends, and branch line piping (that is, potential areas for trapped water) are in areas at or above 40°F (4°C)

Refer to technical data sheet TFP485 about the use of Residential Sprinklers in residential dry pipe systems.

NOTICE

When corrosion-resistant or internally galvanized pipe and fittings with a potable water supply are utilized, return bends need not be installed. However, any portion of the piping that has the potential to trap water must be maintained at or above 40°F (4°C) unless provision to drain such areas is provided and maintained dry.

Water Delivery

When using the Series LFII Residential Pendent Sprinklers (TY2284) in dry pipe sprinkler systems, the requirements for "Dry System Water Delivery" per Section 8.3.4.3 of the 2010 edition of NFPA 13D apply. For a residential hazard, in no case shall the time of water delivery exceed 15 seconds for the most remote operating sprinkler.

Hydraulic Design (NFPA 13D and 13R)

The minimum required sprinkler flow rate for systems designed to NFPA 13D or NFPA 13R are given in Tables A and B as a function of temperature rating and the maximum allowable coverage areas. The sprinkler flow rate is the minimum required discharge from each of the total number of "design sprinklers" as specified in NFPA 13D or NFPA 13R.

NOTICE

The number of "design sprinklers" specified in NFPA 13D and 13R for wet pipe systems is to be applied when designing dry pipe systems. There is no need to increase the design area, as is the case for density/area systems, in accordance with U.S. Patent 7,712,543. Refer to technical data sheet TFP485 for details.

Hydraulic Design (NFPA 13)

For systems designed to NFPA 13, the number of design sprinklers is to be the four most hydraulically demanding sprinklers. The minimum required discharge from each of the four sprinklers is to be the greater of the following:

- The flow rates given in Tables A and B for NFPA 13D and 13R as a function of temperature rating and the maximum allowable coverage area.
- A minimum discharge of 0.1 GPM/sq. ft. over the "design area" comprised of the four most hydraulically demanding sprinklers for the actual coverage areas being protected by the four sprinklers.

NOTICE

The number of "design sprinklers" specified in NFPA 13 for wet pipe systems is to be applied when designing dry pipe systems. There is no need to increase the design area, as is the case for density/area systems, in accordance with U.S. Patent 7,712,543. Refer to technical data sheet TFP485 for details.

Obstruction to Water Distribution.

Sprinklers are to be located in accordance with the obstruction rules of NFPA 13D, 13R, and 13 as applicable for residential sprinklers as well as with the obstruction criteria described within the TYCO technical data sheet TFP490.

Operational Sensitivity

The sprinklers are to be installed in the flush position per Figure 1 with the provided escutcheon.

Sprinkler Spacing

The minimum spacing between sprinklers is 8 feet (2,4 m). The maximum spacing between sprinklers cannot exceed the length of the coverage area (Table A) being hydraulically calculated (for example, maximum 12 feet for a 12 ft. x 12 ft. coverage area, or 20 feet for a 20 ft. x 20 ft. coverage area).

Precautionary Warnings for Corrosive Environments

The Series LFII Residential Flush Sprinkler (TY2284) must be installed in a non-corrosive environment. The improper use of corrosive agents such as flux, or other products that contain chloride ions, whether applied internally or externally to the sprinkler system, may result in corrosion of the sprinkler heads, or stress corrosion cracking, which in turn may cause the sprinkler heads to develop leaks, operate unexpectedly or improperly.

Accordingly, it is essential that the Series LFII Residential Flush Sprinkler (TY2284) be installed only by experienced fire sprinkler engineers, who comply fully with NFPA 13, 13D, 13R and 25, ASTM B 813, ASTM B 828 and Copper Development Association (CDA).

Copper sprinkler system piping

Any time copper piping is used in any part of a fire sprinkler system, the copper piping must be installed in conformance with all applicable standards and requirements for copper piping, including: NFPA 13, 13D, 13R and 25, ASTM B 813, ASTM B 828, and Copper Development Association (CDA). Any soldering in any part of a sprinkler system, either internally or externally, must be done with use of only an ASTM B 813 approved flux. Residual flux must be thoroughly REMOVED from both the interior and exterior surfaces of the piping before installing the sprinkler heads. The use of improper flux, or the failure to thoroughly remove proper flux, may result in corrosion of the sprinkler heads or stress corrosion cracking, which in turn may cause the sprinkler heads to develop leaks, operate unexpectedly or improperly.

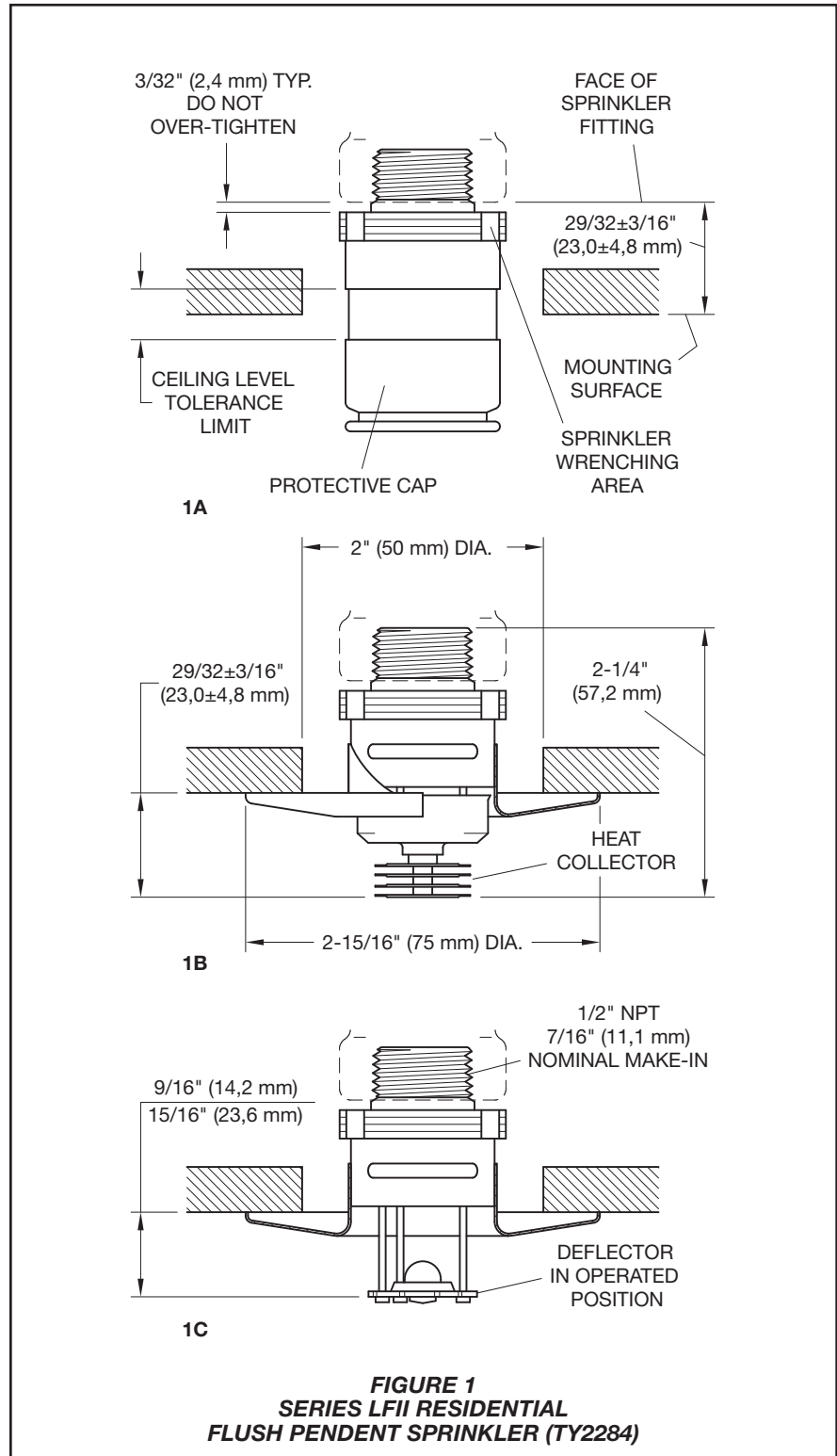

Maximum Coverage Area ^(a) Ft. x Ft. (m x m)	Maximum Spacing Ft. (m)	WET PIPE SYSTEM Minimum Flow and Residual Pressure ^(b)		
		For Horizontal Ceiling ^(c, d, e) (Maximum 2-Inch Rise for 12-Inch Run)	For Sloped Ceiling ^(c, d, e) (Maximum 8-Inch Rise for 12-Inch Run)	For Sloped Ceiling ^(c, d, e) (Maximum 8-Inch Rise for 12-Inch Run)
		162°F (72°C)	162°F (72°C)	162°F (72°C)
12 x 12 (3,7 x 3,7)	12 (3,7)	13 GPM (49,2 LPM) 9.6 psi (0,66 bar)	17 GPM (64,3 LPM) 16.4 psi (1,13 bar)	14 GPM (53,0 LPM) 11.1 psi (0,77 bar)
14 x 14 (4,3 x 4,3)	14 (4,3)	13 GPM (49,2 LPM) 9.6 psi (0,66 bar)	17 GPM (64,3 LPM) 16.4 psi (1,13 bar)	14 GPM (53,0 LPM) 11.1 psi (0,77 bar)
16 x 16 (4,9 x 4,9)	16 (4,9)	14 GPM (53,0 LPM) 11.1 psi (0,77 bar)	17 GPM (64,3 LPM) 16.4 psi (1,13 bar)	14 GPM (53,0 LPM) 11.1 psi (0,77 bar)
18 x 18 (5,5 x 5,5)	18 (5,5)	18 GPM (68,1 LPM) 18.4 psi (1,27 bar)	19 GPM (71,9 LPM) 20.5 psi (1,41 bar)	18 GPM (68,1 LPM) 18.4 psi (1,27 bar)
20 x 20 (6,1 x 6,1)	20 (6,1)	22 GPM (83,3 LPM) 27.4 psi (1,89 bar)	24 GPM (90,8 LPM) 32.7 psi (2,25 bar)	N/A

- (a) For coverage area dimensions less than or between those indicated, use the minimum required flow for the next highest coverage area for which hydraulic design criteria are stated.
- (b) The Minimum Flow requirement is based on minimum flow in GPM (LPM) from each sprinkler. The associated residual pressures are calculated using the nominal K-Factor. Refer to Hydraulic Design under the Design Criteria section.
- (c) For NFPA 13D 2010 applications, Horizontal Ceiling criteria shall be used for certain sloped ceiling configurations up to 8:12 pitch. Refer to TIA 1028R for allowed sloped ceiling limitations when using horizontal ceiling criteria.
- (d) For NFPA 13R applications, Horizontal Ceiling criteria may be used for sloped ceiling configurations up to 8:12 pitch when acceptable to the Local Authority Having Jurisdiction.
- (e) For NFPA 13 residential applications, the greater of 0.1 GPM/Ft.² over the design area or the flow in accordance with the criteria in Table A must be used.

TABLE A
SERIES LFII RESIDENTIAL 4.2 K-FACTOR FLUSH PENDENT SPRINKLERS (TY2284)
NFPA 13, 13D, AND 13R HYDRAULIC DESIGN CRITERIA
WET PIPE SYSTEMS

Maximum Coverage Area ^(a) Ft. x Ft. (m x m)	Maximum Spacing Ft. (m)	DRY PIPE SYSTEM ^(b) Minimum Flow and Residual Pressure For Horizontal Ceiling ^(c) (Maximum 2-Inch Rise for 12-Inch Run)
		162°F (72°C)
12 x 12 (3,7 x 3,7)	12 (3,7)	13 GPM (49,2 LPM) 9.6 psi (0,66 bar)
14 x 14 (4,3 x 4,3)	14 (4,3)	13 GPM (49,2 LPM) 9.6 psi (0,66 bar)
16 x 16 (4,9 x 4,9)	16 (4,9)	13 GPM (49,2 LPM) 9.6 psi (0,66 bar)
18 x 18 (5,5 x 5,5)	18 (5,5)	17 GPM (64,4 LPM) 16.4 psi (1,13 bar)
20 x 20 (6,1 x 6,1)	20 (6,1)	20 GPM (75,7 LPM) 22.7 psi (1,56 bar)

- (a) For coverage area dimensions less than or between those indicated, use the minimum required flow for the next highest coverage area for which hydraulic design criteria are stated.
- (b) The Minimum Flow requirement is based on minimum flow in GPM (LPM) from each sprinkler. The associated residual pressures are calculated using the nominal K-Factor. Refer to Hydraulic Design under the Design Criteria section.
- (c) For NFPA 13D 2010 applications, Horizontal Ceiling criteria shall be used for certain sloped ceiling configurations up to 8:12 pitch. Refer to TIA 1028R for allowed sloped ceiling limitations when using horizontal ceiling criteria.

TABLE B
SERIES LFII RESIDENTIAL 4.2 K-FACTOR FLUSH PENDENT SPRINKLERS (TY2284)
NFPA 13D HYDRAULIC DESIGN CRITERIA
DRY PIPE SYSTEMS

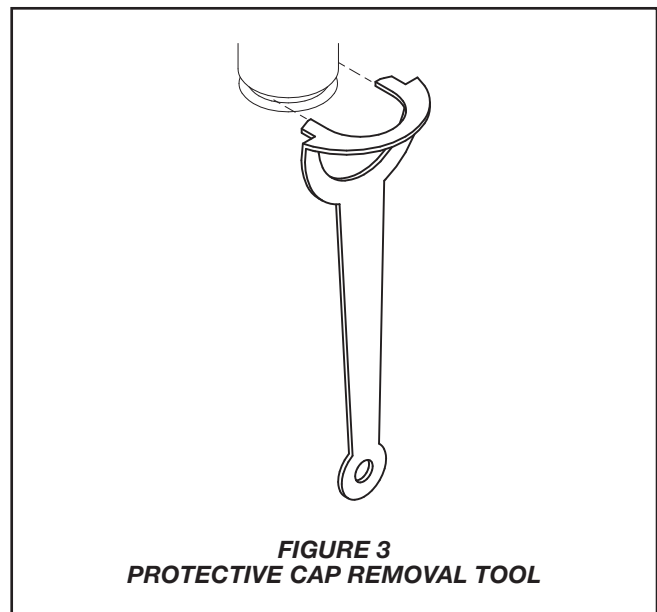
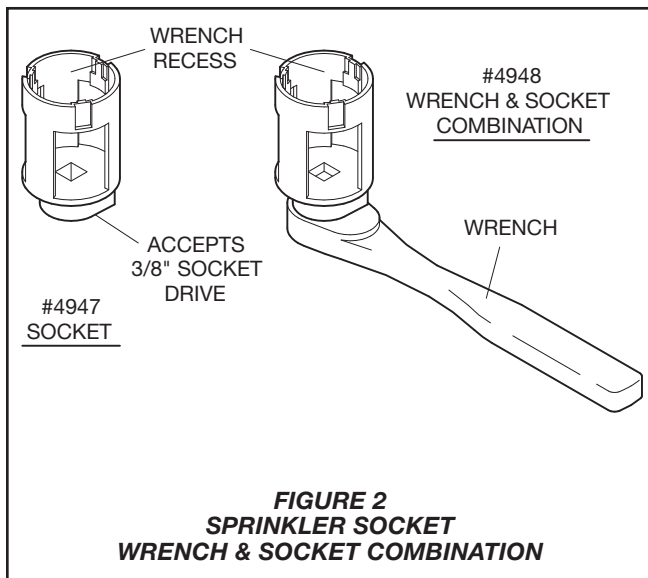

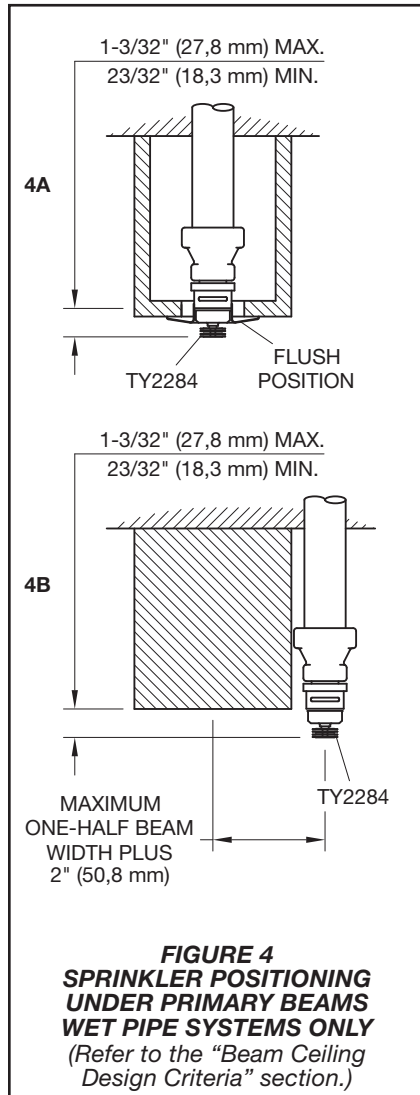

FIGURE 4
SPRINKLER POSITIONING
UNDER PRIMARY BEAMS
WET PIPE SYSTEMS ONLY
(Refer to the "Beam Ceiling Design Criteria" section.)

Beam Ceiling Design Criteria

The RAPID RESPONSE Series LFII Residential Flush Pendent Sprinklers (TY2284) are UL and C-UL Listed for installation in only wet pipe systems for residential occupancies with horizontal ceilings (that is, slopes up to a 2 inch rise over a 12 inch run) with beams when installed in accordance with the following criteria.

General Information

The basic concept of this protection scheme is to locate the sprinklers on the underside of the beams, refer to Figure 4, (not in the beam pockets); to identify the main beams that principally run in one direction as "primary beams"; and, to identify the beams that run principally perpendicular to the main beams, as may be present (or in some cases may be necessary for proper sprinkler protection), as "secondary beams".

Primary and Secondary Beam Types
Solid surface, solid or hollow core, combustible or non-combustible.

Primary and Secondary Beam Positioning

Directly attached to the underside of a combustible or non-combustible smooth ceiling at any elevation.

Primary Beam Cross-Section

Maximum depth of 14 inches and the maximum width is unlimited. The cross-sectional shape of the primary beam may be rectangular to circular.

Secondary Beam Cross-Section

Maximum depth to be no greater than the primary beam and the maximum width is unlimited. The cross-sectional shape of the secondary beam may be rectangular to circular.

Primary Beam Spacing

The primary beams (Figure 5A) are to be 3 ft. - 4 in. to 6 ft. from the compartment wall to center of the nearest beam and from center to center between beams.

Secondary Beam Spacing

The secondary beams principally run perpendicular to the primary beams. Secondary beams of a depth equal to the primary beam must be placed so that the beam pockets created by the primary beams do not exceed 20 feet in length (Figure 5B).

Note: When the beam pockets created by the primary beams exceed 20 feet in length, the installation will require the use of secondary beams as described above. Otherwise, secondary beams need not be present.

Secondary beams of a cross-sectional depth greater than one-quarter the depth of the primary beams are to be a minimum of 3 ft.-4 in. from the compartment wall to center of the nearest beam and from center to center between beams (Figure 5C).

Secondary beams of a cross-sectional depth no greater than one-quarter the depth of the primary beams may be placed at any compartment wall to center of the nearest beam distance and from any center to center distance between beams (Figure 5C).

Lintels

Lintels over doorways exiting the compartment must be present. The minimum height for the lintels is 8 inches or no less than the depth of the Primary Beams, whichever is greater.

Sprinkler Types

Series LFII Residential Flush Pendent Sprinklers (TY2284), 162°F (72°C).

Sprinkler Coverage Area and Hydraulic Design

The sprinkler coverage areas and hydraulic design criteria as presented in the Table A for "Horizontal Ceilings" are to be applied.

Sprinkler Position

The bottom of heat collector to bottom of primary beams for the Series LFII (TY2284) Flush Pendent Sprinklers is to be 23/32 to 1-3/32 inches (Figure 4A). The vertical center-line of the Series LFII Flush Pendent Sprinklers (TY2284) is to be no greater than half the primary beam cross-sectional width plus 2 inches from the center-line of the primary beam (Figure 4B).

NOTICE

Core drilling of beams to allow the installation of sprinkler drops requires consulting with a structural engineer.

Where core drilling is not permitted, the previously stated sprinkler position criteria for the Series LFII Residential Flush Pendent Sprinklers (TY2284) allows for the sprinkler drop to be placed adjacent to the primary beam.

Beam and Soffit Arrangements

A soffit is permitted to be placed around the perimeter of a compartment with the beam arrangement within the soffit area (Figure 6).

The cross-section of the soffit may be any size as long as it does not create an obstruction to water distribution per the obstruction rules of NFPA 13 for residential sprinklers.

When soffits are present, the previously provided 3 ft.-4 in. to 6 ft. "compartment wall to adjacent beam" distance for the primary and secondary beams is to be measured from the face of the soffit as opposed to the compartment wall.

Note: Although the distance to the beams is measured from the face of the soffit, the sprinkler coverage area is to be measured from the compartment wall.

ALL FIGURES:
DISTANCES ARE
MEASURED TO
COMPARTMENT
WALL FACES AND
TO CENTERLINES
OF BEAMS

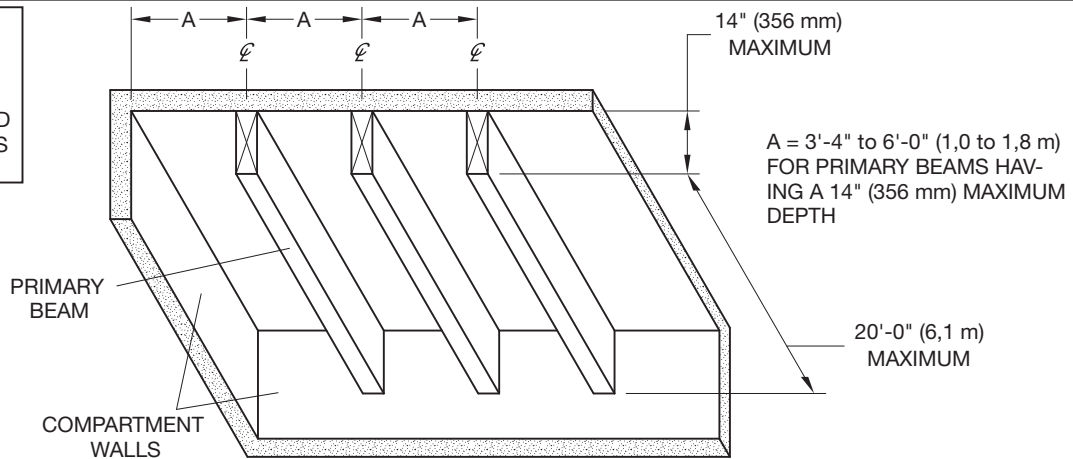

FIGURE 5A

PRIMARY BEAM SPANS UP TO 20'-0" (6,1 m)

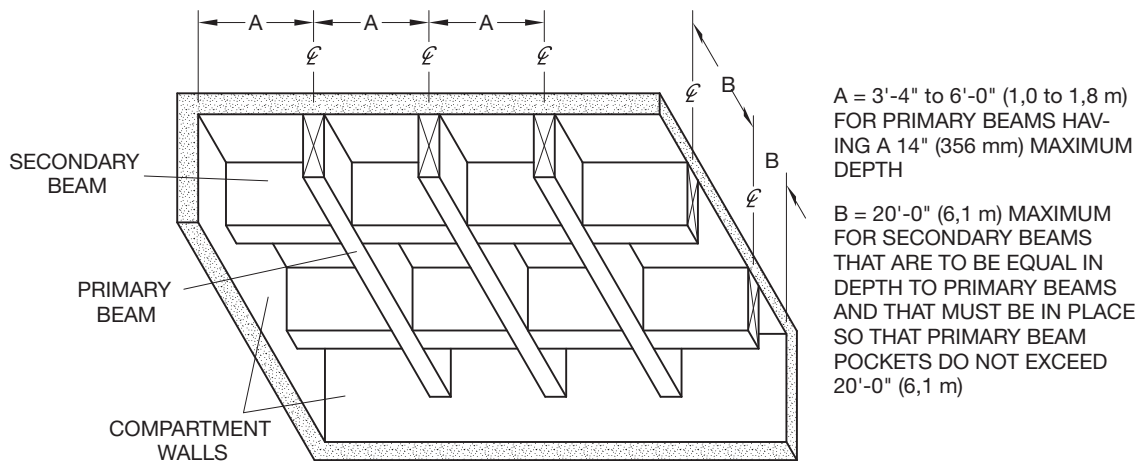

FIGURE 5B

PRIMARY BEAM SPANS GREATER THAN 20'-0" (6,1 m)

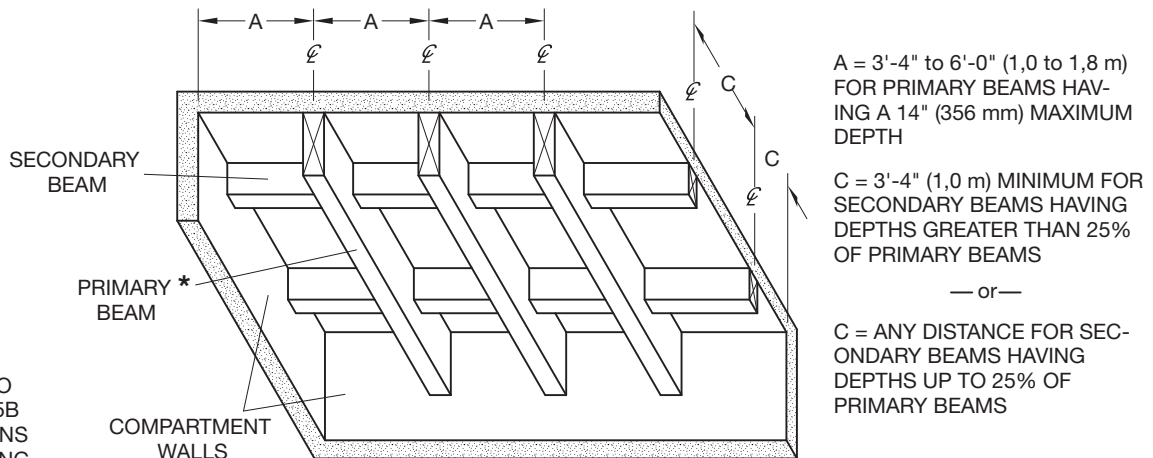

FIGURE 5C

COMBINATIONS OF PRIMARY AND SECONDARY BEAMS

* REFER TO
FIGURE 5B
FOR SPANS
EXCEEDING
20'-0" (6,1 m)

**FIGURE 5
BEAM ARRANGEMENTS
WET PIPE SYSTEMS ONLY**

(Refer to the "Beam Ceiling Design Criteria" section.)

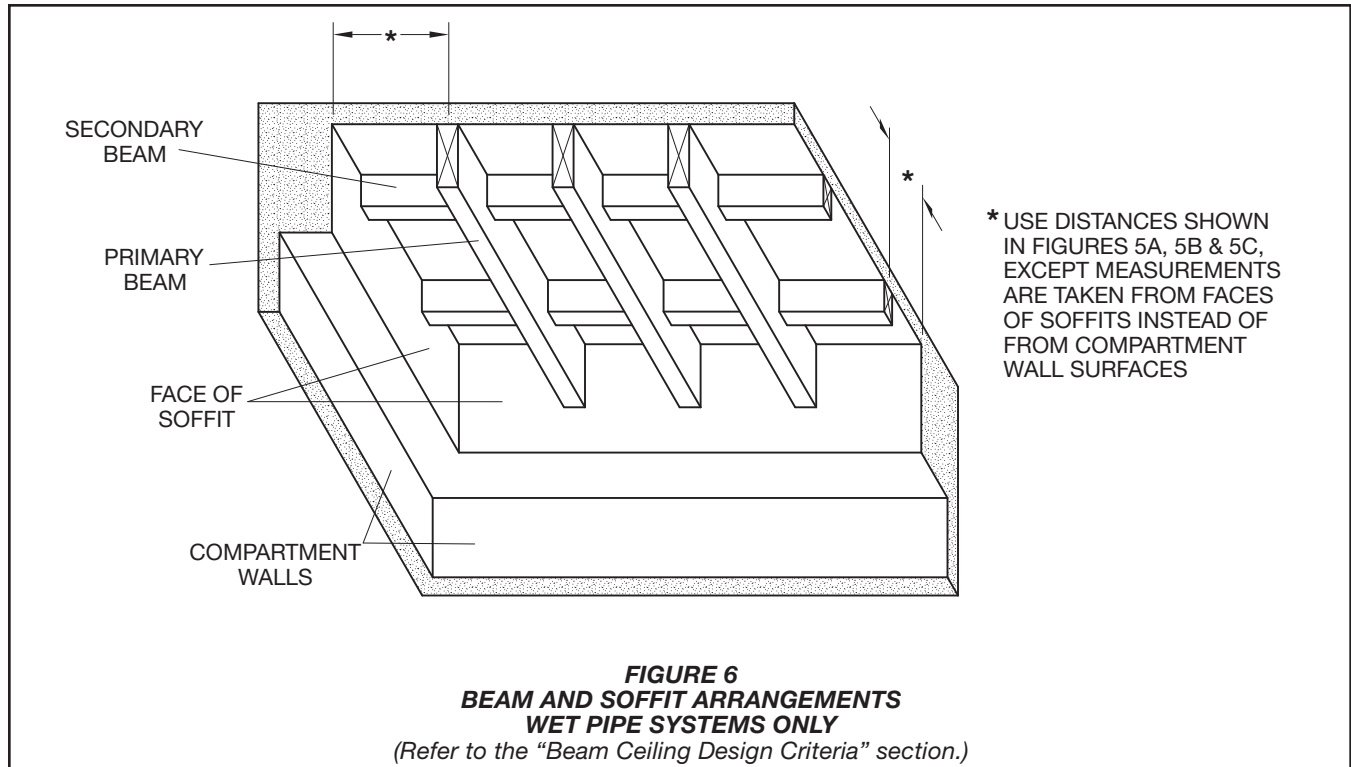

Installation

The RAPID RESPONSE Series LFII Residential Flush Pendent Sprinklers (TY2284) must be installed in accordance with the following instructions.

NOTICE

The Protective Cap is to remain on the sprinkler during installation until the ceiling installation is complete. The Protective Cap must be removed to place the sprinkler in service.

Obtain a leak-tight 1/2 inch NPT sprinkler joint by applying a minimum-to-maximum torque of 7 to 14 ft. lbs. (9,5 to 19,0 Nm). Higher levels of torque can distort the sprinkler Inlet with consequent leakage or impairment of the sprinkler.

Do not attempt to compensate for insufficient adjustment in the Sprinkler by under- or over-tightening the Sprinkler/Support Cup Assembly. Re-adjust the position of the sprinkler fitting to suit.

Each sprinkler must be inspected before installation. Do not use any sprinkler that exhibits any deformations or cracks, including cracks on the protective cap.

1. The Sprinkler must be installed only in the pendent position and with the Sprinkler waterway center-line perpendicular to the mounting surface.

2. Install the sprinkler fitting so that the distance from the face of the fitting to the mounting surface will be nominally 29/32 inches (23,0 mm) as shown in Figure 1A.

3. With pipe-thread sealant applied to the pipe threads, hand-tighten the sprinkler into the sprinkler fitting.

4. Tighten the sprinkler using only the Sprinkler Socket or Wrench & Socket Combination (Figure 2). The wrench recess of the Socket is to be applied to the sprinkler wrenching area (Figure 1A).

5. Use the "ceiling level tolerance limit" indicator on the Protective Cap to check for proper installation height. Relocate the sprinkler fitting as necessary. If desired the Protective Cap may also be used to locate the center of the clearance hole by gently pushing the ceiling material against the center point of the Cap.

6. After the ceiling has been completed with the 2 inch (50 mm diameter) clearance hole, use the Protective Cap Removal Tool (Figure 3) to remove the Protective Cap and then push on the Escutcheon until its flange just comes in contact with the ceiling. Do not continue to push the Escutcheon such that it lifts a ceiling panel out of its normal position. If the Escutcheon cannot be engaged with the Sprinkler, or the Escutcheon cannot be engaged sufficiently to contact the ceiling, relocate the sprinkler fitting as necessary.

Care and Maintenance

The RAPID RESPONSE Series LFII Residential Flush Pendent Sprinklers (TY2284) must be maintained and serviced in accordance with the following instructions.

NOTICE

Before closing a fire protection system main control valve for maintenance work on the fire protection system that it controls, obtain permission to shut down the affected fire protection systems from the proper authorities and notify all personnel who may be affected by this action.

Absence of the outer piece of an escutcheon, which is used to cover a clearance hole, can delay sprinkler operation in a fire situation.

Owners must assure that the sprinklers are not used for hanging of any objects and that the sprinklers are only cleaned by means of gently dusting with a feather duster; otherwise, non-operation in the event of a fire or inadvertent operation may result.

Exercise care to avoid damage to sprinklers before, during, and after installation. Never paint, plate, coat, or otherwise alter automatic sprinklers after they leave the factory.

Replace sprinklers that:

- were modified or over-heated.
- were damaged by dropping, striking, wrench twisting, wrench slippage, or the like.
- are leaking or exhibiting visible signs of corrosion.
- were exposed to corrosive products of combustion but have not operated, if you cannot easily remove combustion by-products with a cloth.

For the Cover Plate/Retainer Assembly, the following items apply:

- When properly installed, a nominal 3/32 inch (2,4 mm) air gap exists between the lip of the Cover and the ceiling, as shown in Figure 4. This air gap is necessary for proper sprinkler operation. The air gap allows heat flow from a fire to pass below and above the Cover, helping to assure appropriate release of the Cover in a fire situation. If repainting the ceiling after installation is required, exercise care to ensure that new paint does not seal off any of the air gap.

- Do not pull the Cover relative to the Retainer. Separation may result.
- Never repaint factory-painted Covers. When necessary, replace Covers with factory-painted units.

Responsibility lies with the owner for the inspection, testing, and maintenance of their fire protection system and devices in compliance with this document, as well as with the applicable standards of the National Fire Protection Association (for example, NFPA 25), in addition to the standards of any authorities having jurisdiction. Contact the installing contractor or sprinkler manufacturer regarding any questions.

Automatic sprinkler systems are recommended to be inspected, tested, and maintained by a qualified Inspection Service in accordance with local requirements and/or national codes.

Limited Warranty

Products manufactured by Tyco Fire Suppression & Building Products (TFSBP) are warranted solely to the original Buyer for ten (10) years against defects in material and workmanship when paid for and properly installed and maintained under normal use and service. This warranty will expire ten (10) years from date of shipment by TFSBP. No warranty is given for products or components manufactured by companies not affiliated by ownership with TFSBP or for products and components which have been subject to misuse, improper installation, corrosion, or which have not been installed, maintained, modified or repaired in accordance with applicable Standards of the National Fire Protection Association, and/or the standards of any authorities having jurisdiction. Materials found by TFSBP to be defective shall be either repaired or replaced, at TFSBP's sole option. TFSBP neither assumes, nor authorizes any person to assume for it, any other obligation in connection with the sale of products or parts of products. TFSBP shall not be responsible for sprinkler system design errors or inaccurate or incomplete information supplied by Buyer or Buyer's representatives.

In no event shall TFSBP be liable, in contract, tort, strict liability or under any other legal theory, for incidental, indirect, special or consequential damages, including but not limited to labor charges, regardless of whether TFSBP was informed about the possibility of such damages, and in no event shall TFSBP's liability exceed an amount equal to the sales price.

The foregoing warranty is made in lieu of any and all other warranties, express or implied, including warranties of merchantability and fitness for a particular purpose.

This limited warranty sets forth the exclusive remedy for claims based on failure of or defect in products, materials or components, whether the claim is made in contract, tort, strict liability or any other legal theory.

This warranty will apply to the full extent permitted by law. The invalidity, in whole or part, of any portion of this warranty will not affect the remainder.

Ordering Procedure

Contact your local distributor for availability. When placing an order, indicate the full product name and Part Number (P/N).

Sprinkler Assembly

Specify Series LFII Residential Flush Pendent Sprinkler (TY2284), K=4.2, 162°F (72°C) temperature rating, (finish), and P/N (below).

Chrome Plated P/N 51-123-9-162
Signal White (a)
(RAL9003) P/N 51-123-4-162
Black P/N 51-123-6-162
Antique Brass P/N 51-123-1-162

(a) Previously known as Bright White.

Escutcheon

Specify Escutcheon with (finish), P/N (below). Refer to Technical Data Sheet TFP770.

Chrome P/N 56-123-9-001
Signal White (a)
(RAL9003) P/N 56-123-4-001
Black P/N 56-123-6-001
Antique Brass P/N 56-123-1-001

Accessories

- Wrench and Socket
Specify Series LFII Residential Flush Pendent Sprinkler (TY2284), P/N 56-000-4-948.
- Socket
Specify Series LFII Residential Flush Pendent Sprinkler (TY2284), P/N 56-000-4-947.
- Protective Cap Removal Tool
Specify Series LFII Residential Flush Pendent Sprinkler (TY2284), P/N 56-000-4-300.