

# Reliable®

## Model RFS42 Residential Flat Concealed Horizontal Sidewall Sprinkler (SIN RA4835)

### Coverage to 16 ft. x 20 ft. (4.9m x 6.1m)

#### Features:

1. Flat cover plate for a flush, concealed wall finish.
2. 4.2 (60 metric) K Factor.
3. Sized to fit in a 3½" or larger stud space even when installed directly in a TorqueSafe™ 90° Sprinkler Head Elbow\*\* and several other common ½" and ¾" by ½" sprinkler fittings.
4. Push-on/pull-off flat cover plate.
5. Sprinkler shipped complete with factory installed protective cap.
6. Sprinkler assembly and cover plate packaged separately.
7. 1/8" (3.2 mm) cover plate adjustment.
8. Model RFS Cover plate available in a wide variety of colors and finishes.

#### Listings & Approvals

1. Listed by Underwriters Laboratories Inc. and UL certified for Canada (cULus).

#### UL Listing Category

Residential Automatic Sprinklers

#### UL Guide Number

VKKW

#### Patents:

**U.S. Patent No. 7,353,882, other Patents pending**

#### Product Description

The Reliable Model RFS42 Concealed Residential Extended Coverage Horizontal Sidewall Sprinkler is an attractive, concealed sprinkler assembly specially sized to fit within a 3½" or larger stud space. The sprinkler uses a push-on/pull-off flat cover plate assembly. The sprinkler assembly is shipped with a protective cap.

The flat cover plate is attached to the skirt using 135°F (57°C) ordinary temperature classification solder. The sprinkler is installed into the sprinkler fitting using the Model G6 Sprinkler Wrench.

When the ambient temperature rises, the solder holding the cover plate melts, allowing the release of this part and thus exposing the sprinkler inside to the rising ambient temperature.

This sprinkler is listed for a maximum service pressure of 175 psi (12,0 bar).



#### Application and Installation

The Model RFS42 sprinkler is intended for installation in the residential portions of any occupancy in accordance with NFPA 13, 13R & 13D. The sprinkler is listed as a Concealed Residential Horizontal Sidewall Sprinkler. System design and installation requirements for ceiling configurations are described in NFPA 13, 13R or 13D, as applicable.

The minimum listed spacing between Model RFS42 sprinklers is 8 ft (2.4 m).

The low flow RFS42RES sprinklers are specifically engineered to meet the latest residential sprinkler listing standards (UL 1626 Standard).\*

The sprinkler must be installed and properly oriented with the Model G6 Wrench:

Do not remove the factory installed plastic protective cap since it is sized to fit inside the G6 wrench. Note that the sprinkler can only mate when the sprinkler's deflector orientation tab (Fig. 1) is aligned with wrench's key-way. The G6 wrench is provided with bubble level pad and TOP marking, to allow the proper orientation of the horizontal sidewall deflector. Final leveling can be done after leak proof joint is obtained with a minimum to maximum torque of 8 to 18 ft-lbs (11 to 24 N·m). Leave the protective cap on to protect the sprinkler while the wall is plastered, wallpapered or painted. The protective cap must be removed and the listed cover plate installed prior to the sprinkler system being placed in service. A 2<sup>5</sup>/<sub>8</sub>" (67 mm) diameter hole must be cut in the wall for the sprinkler assembly to extend through.

Concealed cover plate/cup assemblies are listed only for use with specific sprinklers. The use of any other concealed cover plate/cup assembly with the Model RFS42 Horizontal Sidewall Sprinkler or the use of this dedicated concealed cover plate assembly on any sprinkler with which it is not specifically listed will void all guarantees, warranties, listings and approvals.

\* Effective date 3/14/2008

\*\*Spears Manufacturing Company

**Technical Data:**

Orifice Size	"K" Factor		Thread Size	Maximum Ambient Temperature	Maximum Water Working Pressure	Sprinkler Identification Number (SIN)	Approvals
	US	Metric					
3/8" (9.6mm)	4.2	60	1/2" NPT (R1/2)	100°F (38°C)	175 PSI (12 bar)	RA4835	cULus

Listed Design Criteria***									
Max. Coverage Area Width x Length		Deflector to Ceiling Dimension		Flow Rate		Pressure		Temperature Rating	
ft. x ft.	m x m	inches	mm	gpm	L/min	psi	bar	Sprinkler	Cover
12 x 12	3.6 x 3.6	4 - 6	102 - 152	12	45.4	8.2	0.57	165°F (74°C)	135°F (57°C)
12 x 12	3.6 x 3.6	6 - 12	152 - 305	13	49.2	9.6	0.67		
14 x 14	4.3 x 4.3	4 - 6	102 - 152	12	45.4	8.2	0.57		
14 x 14	4.3 x 4.3	6 - 12	152 - 305	14	53.0	11.1	0.78		
16 x 16	4.9 x 4.9	4 - 12	102 - 305	16	60.6	14.5	1.01		
16 x 18	4.9 x 5.5	4 - 12	102 - 305	18	68.1	18.4	1.29		
16 x 20	4.9 x 6.1	4 - 6	102 - 152	22	83.3	27.4	1.92		
16 x 20	4.9 x 6.1	6 - 12	152 - 305	23	87.0	30.0	2.10		

\*\*\*For NFPA 13 systems calculate for a minimum design density of 0.1 gpm/sf, but in no case go below the Listed Design Criteria Flow Rate and Pressure.

**Material Data**

<b>Bronze</b>	Sprinkler Body, Spring Closure Cap, Yoke, Lever, Slide Pin, Slide Plate, Deflector, Set Screw
<b>Brass</b>	Cover Plate, Sprinkler Sleeve, Frame Arms
<b>Stainless Steel</b>	Push Spring, Ball, Load Screw, Rivet
<b>Copper Plated Steel</b>	Cover Plate Skirt
<b>Nickel Alloy</b>	Fusible Element
<b>Nickel Alloy coated with PTFE Adhesive Tape</b>	Sealing Washer

**Installation Guide for 3 1/2" or Larger Stud Space**

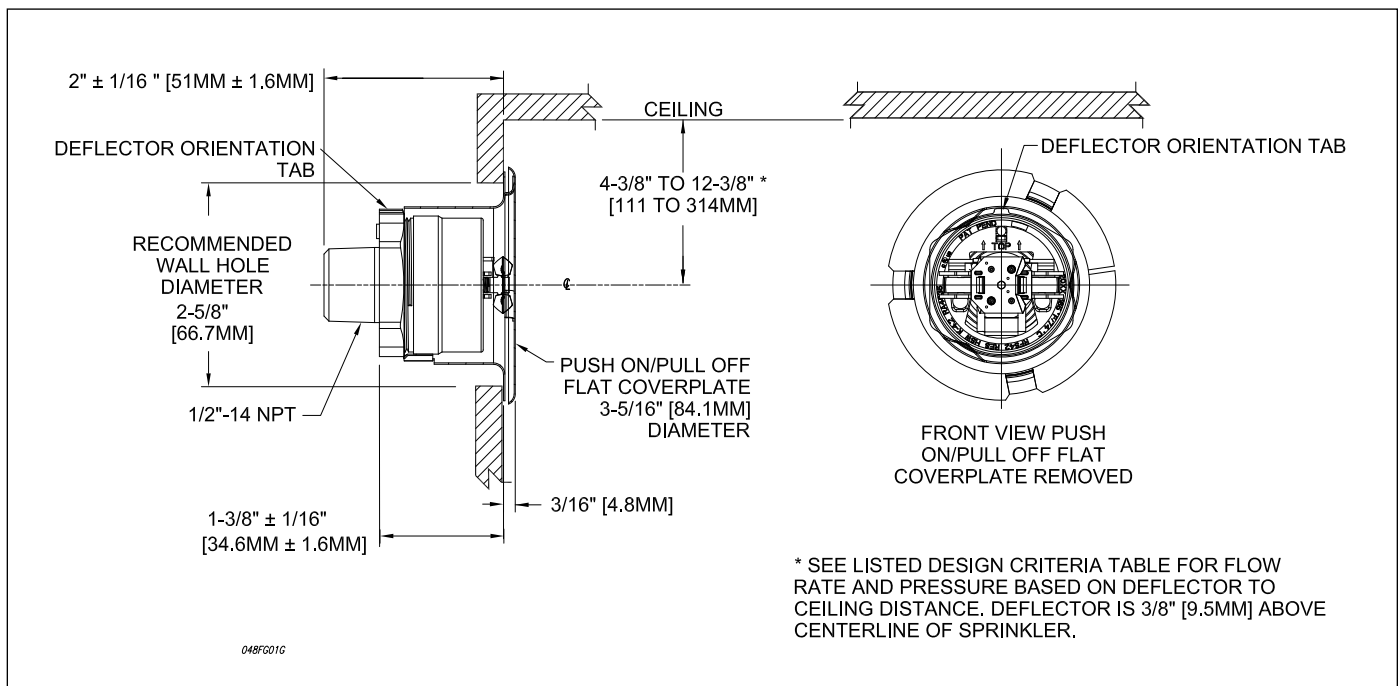

Fig. 1

**Attachment Method:**

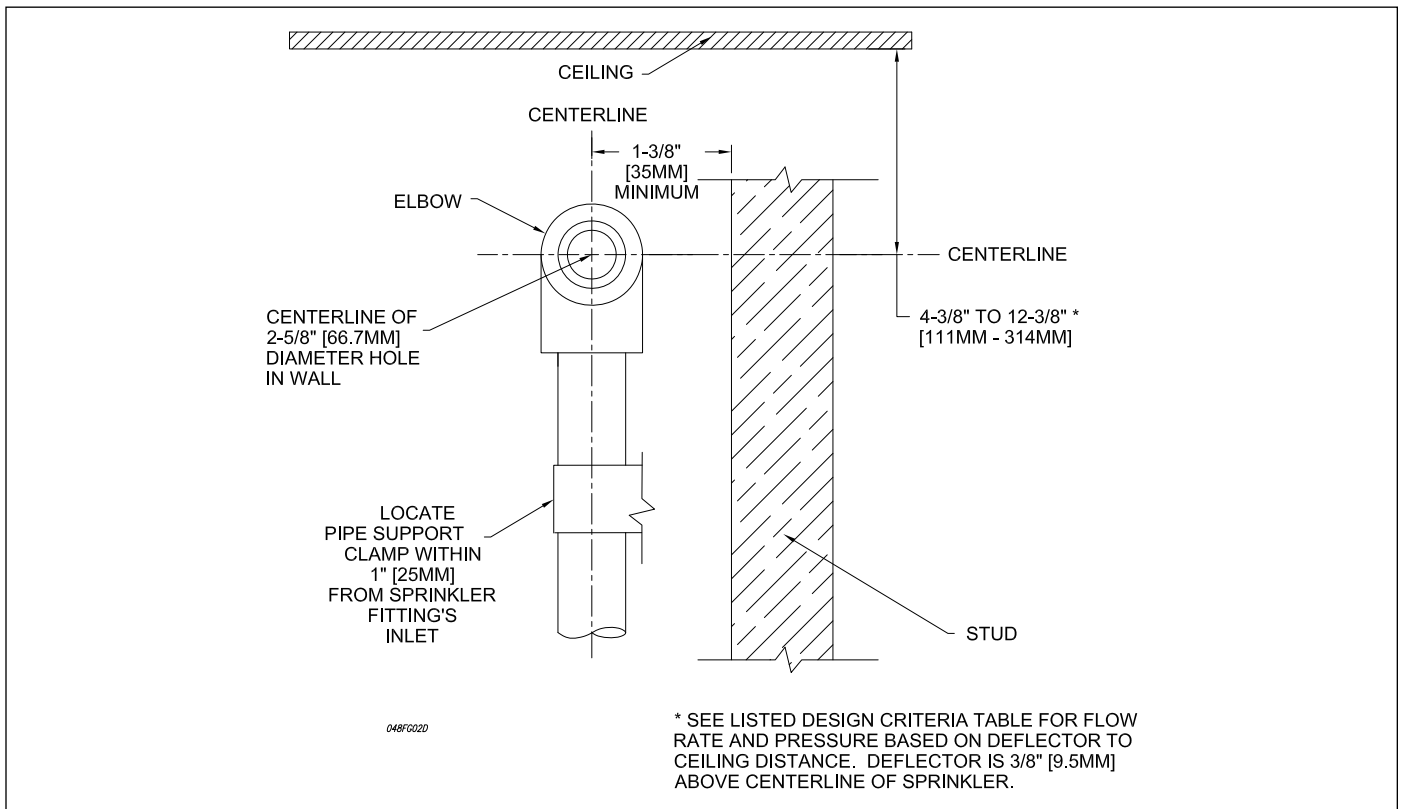

Fig. 2  
Front View

**Fig. 3:**

1. Securely support pipe from adjacent stud.
2. Pipe support clamp shall be located within 1" [25 mm] of sprinkler fitting's inlet lip.
3. The center of the sprinkler fitting shall be located at a horizontal distance of 1<sup>3</sup>/<sub>8</sub>" [35 mm] or more from the stud (Fig. 3).
4. The sprinkler fitting shall be installed so that the rear of the sprinkler is 2<sup>1</sup>/<sub>16</sub>" +/- 1<sup>1</sup>/<sub>16</sub>" from the finished surface of the wall. Verify wall assembly dimensions prior to installation to ensure that the cover plate attaches to the sprinkler and seats against the finished wall surface (Fig. 1).

**5. Maintenance**

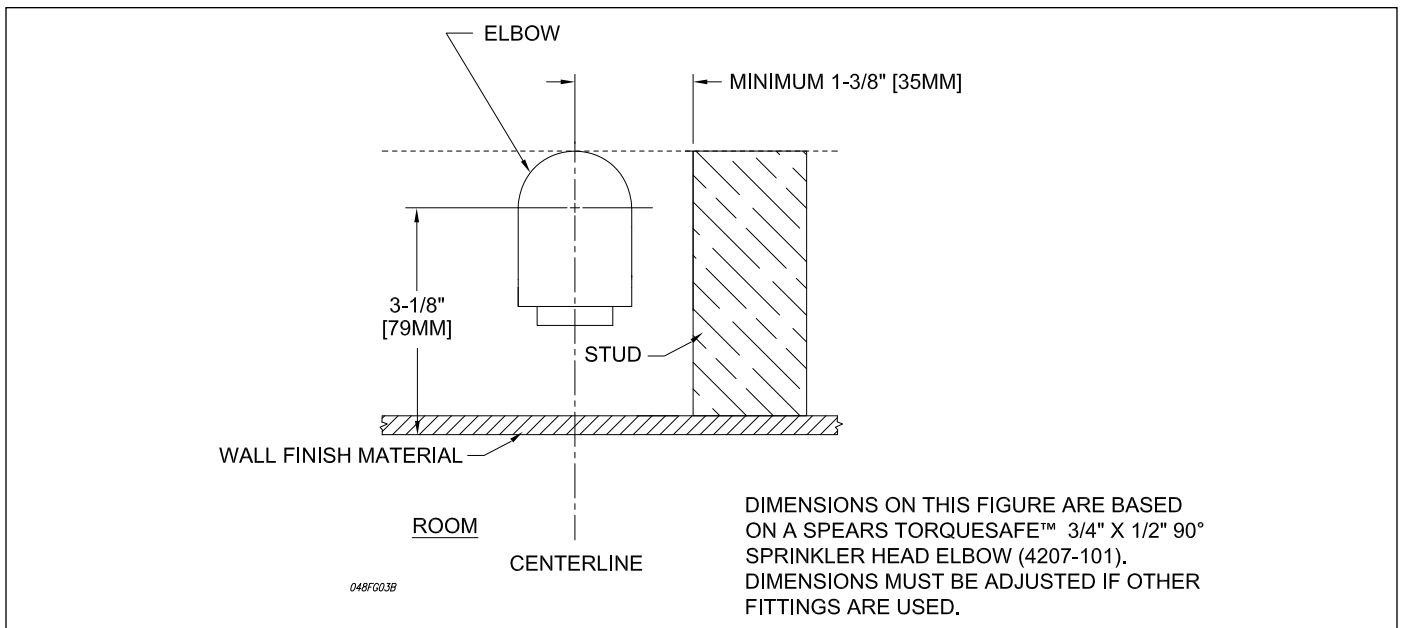

Fig. 3

Model RFS42 Concealed Sprinklers should be inspected and maintained in accordance with NFPA 25. Do not clean sprinklers with soap and water, ammonia or any other cleaning fluids. Remove dust by using a soft brush or gentle vacuuming. Replace any sprinkler or cover plate assembly, which has been painted (other than factory applied) or damaged in any way. A stock of spare sprinklers should be maintained to allow quick replacement of damaged or operated sprinklers. Prior to installation, sprinklers should be maintained in their original cartons and packaging until used to minimize the potential for damage to sprinklers that would cause improper operation or non-operation. Once operated automatic sprinklers and cover plates cannot be reassembled and reused. New sprinklers of the same size, type and temperature rating must be installed. A cabinet of replacement sprinklers should be provided for this purpose.

### Model RFS42 Residential Flat Cover Concealed Horizontal Sidewall Sprinkler Specification

Sprinklers shall be a UL listed as residential flat cover concealed horizontal sprinkler with RFS42 deflector and adjustable cover plate for light hazard, interior, non-corrosive applications. Sprinklers to be of bronze frame construction with brass cover plate and copper alloy retainer flange assembly. Water seal assembly shall consist of a PTFE coated Belleville spring washer and machined brass cup containing no plastic parts. Method of attaching the cover plate to the sprinkler cup shall be a Push-on and Pull-off design allowing a 1/8" cover plate adjustment. Sprinklers shall have a nominal K-factor of 4.2 (60 metric), and 1/2" NPT thread. Sprinkler temperature rating shall be 165°F (74°C) with a cover plate temperature rating of 135°F (57°C). Sprinklers shall be capable of a maximum coverage area of 16 ft. x 20 ft. (4.9 m x 6.1 m), with a minimum lateral spacing of 8 ft. (2.4 m). Rated working pressure shall be 175 psi (12,0 bar). A plastic protective cap shall be provided and factory installed onto the sprinkler cup to protect the sprinkler from damage, which could occur during construction before the cover plate is installed. Cover plate finish: [White] [Custom Color-specify]. Residential Coverage Concealed horizontal sidewall sprinklers shall be Reliable Model RFS42. SIN RA4835 (Bulletin 048).

### Cover Plate Finishes<sup>(1)</sup>

<b>Standard Finish</b>
White
<b>Special Application Finishes</b>
Flat White Paint
Off White Paint
Black Paint
Custom Color Paint
Bright Brass
Bronze
Chrome
Satin Chrome
Black Plating

<sup>(1)</sup> Other colors and finishes are available. Consult factory for details.

**Note:** Paint or any other coatings applied over the factory finish will void all approvals and warranties.

### Ordering Information

Specify:

1. Model RFS42 Residential Sidewall
2. Model RFS Cover Plate Finish

### Installation Wrench

Model G6 Sprinkler Wrench

### Installation Aid

A protective plastic cap is included for use during installation.

The equipment presented in this bulletin is to be installed in accordance with the latest published Standards of the National Fire Protection Association, Factory Mutual Research Corporation, or other similar organizations and also with the provisions of governmental codes or ordinances whenever applicable. Products manufactured and distributed by Reliable have been protecting life and property for over 90 years, and are installed and serviced by the most highly qualified and reputable sprinkler contractors located throughout the United States, Canada and foreign countries.

Manufactured by



#### Reliable Automatic Sprinkler Co., Inc.

(800) 431-1588 Sales Offices  
 (800) 848-6051 Sales Fax  
 (914) 829-2042 Corporate Offices  
 www.reliablesprinkler.com Internet Address



Revision lines indicate updated or new data.

EG. Printed in U.S.A. 11/19 P/N 999970457