



Clean Agent HFC-227ea

CG2XXXX227-BXXXX

Automatic, 175°F (79°C)

Sizes: 25-1000 cu. ft.

0.7-28.3 cu. m

MA2XXXX227-BLXXX

Manual/Automatic, 175°F (79°C)

Sizes: 25-1500 cu. ft.

0.7-42.5 cu. m

Owner's Manual
&
Installation Instructions



APPROVED

Project ID: 0003045895

U.S. Coast Guard Approved

No. 162.029/249/0

No. 162.029/251/0

Read and comply with all instructions, warnings and limitations before installing, servicing or removing this device.

Additional copies of this manual are available at no charge by contacting the manufacturer, distributor or dealer. Fireboy-Xintex reserves the right to change features without notice.

General Information	3
Specifications	4
Operation of Fireboy Fire Extinguisher	7
Marine Installation Instructions	8
Before Installation	8
Selecting Location	8
Mounting Fireboy System	10
Cable Installation (P/N: E-4209-XXX, XXX = Length in Feet)	11
Routing Cable	12
Legend Plate and T-Handle	13
Connecting Cable to Cylinder	15
Accommodating Diesel Engines	18
Installing Indicator Lamp (P/N: 90107)	18
Mounting Indicator Lamp	18
Wiring Indicator Lamp	19
Connecting to Powered Ventilation	20
Installation Checklist	21
Maintaining Fireboy Fire Extinguisher	22
Disconnection and Inspection of Manual Discharge Cable	22
Maintaining the Indicator Lamp Circuit	23
Health and Safety	23
Additional Equipment	25
Safety Data Sheet	26
Returning Fireboy-Xintex Equipment	32
Recharging Fireboy Extinguishers	32
3 Year Limited Warranty	33

General Information

Fireboy Automatic (CG series) and Manual/Automatic (MA) series Fire Extinguishing Systems are manufactured for a broad range of applications, including marine, industrial, and commercial uses. This booklet is intended to outline the proper installation of the system for marine applications; most applications are similar. If further technical advice is required, information is available by contacting Fireboy-Xintex.

Fireboy FM Component Approved HFC-227ea Systems are approved for use in normally occupied spaces and are approved for use within the European Union.

The National Fire Protection Agency defines normally occupied enclosure or space as “an enclosure or space where one or more persons are present under normal conditions.” (NFPA-2001).

SDS Sheets are available at no charge from the manufacturer and online at www.fireboy-xintex.com.

Referenced Agencies:

Bureau Veritas
3663 N. Sam Houston Pkwy. E., Suite 200
Houston, TX 88034

National Fire Protection Agency
1 Batterymarch Park
Quincy, MA 02269-9101
NFPA 2001, Standard on Clean Agent Fire Extinguishant Systems

FM Approvals
1151 Boston Providence Turnpike
Norwood, MA 02062

United States Coast Guard
2100 Second Street SW
Washington, DC 20593-0001

RINA
10 Upper Belgrave Street
London, SW1X 8BQ

WARNING:

1. NEVER INSTALL A FIREBOY SYSTEM ON THE UNDERSIDE OF A HATCH COVER OR ON AN ACCESS DOOR THAT MAY OPEN OR SEPARATE IN AN EXPLOSION
2. NEVER INSTALL THE ACTUATOR OF A FIREBOY SYSTEM IN CLOSE PROXIMITY TO EXHAUST MANIFOLDS OR TURBOCHARGERS. RADIATED HEAT MAY CAUSE PREMATURE ACTUATION
3. NEVER INSTALL THE ACTUATOR OF A FIREBOY SYSTEM BELOW THE CYLINDER (UPSIDE DOWN)
4. NEVER INSTALL A FIREBOY SYSTEM WHERE IT WILL TRAP OR BE IN DIRECT CONTACT WITH WATER
5. NEVER INSTALL A FIREBOY UNIT IN A COMPARTMENT LARGER THAN ITS VOLUME RATING
6. NEVER COMBINE THE VOLUME RATING OF TWO OR MORE FIREBOY UNITS TO PROTECT A GIVEN COMPARTMENT
7. THIS DEVICE SHALL NOT BE INSTALLED OR USED IN AIRCRAFT AND/OR RACING VEHICLES
8. DIESEL POWERED CRAFT MUST ALSO INSTALL THE AUTOMATIC ENGINE SHUTDOWN SYSTEM OR THIS SYSTEM MAY NOT EXTINGUISH THE FIRE (SEE ADDITIONAL EQUIPMENT)
9. FIREBOY SYSTEMS ARE NOT, NOR ARE THEY INTENDED TO BE, EXPLOSION SUPPRESSION DEVICES. THEY DO NOT LESSEN THE NEED TO INSPECT FOR FIRE HAZARDS AND TO VENTILATE ANY AREA WHERE FLAMMABLE FUMES MAY ACCUMULATE.
10. IN CASE OF ACCIDENTAL DISCHARGE, EVACUATE PROTECTED SPACE AND VENTILATE. DO NOT RETURN TO AREA UNTIL SPACE IS CLEAR OF AGENT. REFER TO HEALTH AND SAFETY SECTION (PAGE 23).

Specifications

CG2XXXX227-BXXXX and MA2XXXX227-BLXXX series extinguishers discharge automatically at a temperature of 175°F (79°C). MA2XXXX227-BLXXX series extinguishers may be discharged manually at any temperature. All models introduce an atmospheric concentration of 8.7% into the protected space. This concentration includes a 30% safety factor to the 6.7% Minimum Extinguishing Concentration (MEC). Operational temperature range of extinguishers is 32°F (0°C) to 130°F (54°C).

Model Number	Volume Protected		Diameter		Total Height		Agent Weight		Shipping Weight		System Pressure (@70° F)
	ft ³	m ³	in	mm	in	mm	lbs	kgs	lbs	kgs	psi
CG20025227-BXXXX	25	0.7	3.3	85	9.5	241	1.1	0.5	5	2.4	240
CG20050227-BXXXX	50	1.4	3.3	85	13.3	338	2.2	1.0	8	3.7	240
CG20075227-BXXXX	75	2.1	4.3	110	15.6	396	3.2	1.5	13	6.0	240
CG20100227-BXXXX	100	2.8	4.3	110	15.6	396	4.3	2.0	14	6.4	240
CG20125227-BXXXX	125	3.5	4.3	110	15.6	396	5.4	2.5	15	6.9	240
CG20150227-BXXXX	150	4.3	5.1	130	17.2	436	6.5	2.9	20	9.2	240

Model Number	Volume Protected		Diameter		Total Height		Agent Weight		Shipping Weight		System Pressure (@70° F)
	ft ³	m ³	in	mm	in	mm	lbs	kgs	lbs	kgs	psi
CG20175227-BXXXX	175	4.9	5.1	130	17.2	436	7.6	3.4	21	9.6	240
CG20200227-BXXXX	200	5.7	5.1	130	17.2	436	8.6	3.9	22	10.0	240
CG20225227-BXXXX	225	6.4	6.3	160	17.3	439	9.7	4.4	29	13.2	240
CG20250227-BXXXX	250	7.0	6.3	160	17.3	439	10.8	4.9	30	13.6	240
CG20275227-BXXXX	275	7.8	6.3	160	17.3	439	11.9	5.4	31	14.1	240
CG20300227-BXXXX	300	8.5	6.3	160	17.3	439	13.0	5.9	32	14.5	240
CG20325227-BXXXX	325	9.2	7.1	180	17.2	437	14.0	6.4	37	16.9	240
CG20350227-BXXXX	350	10.0	7.1	180	17.2	437	15.1	6.9	38	17.4	240
CG20375227-BXXXX	375	10.6	7.1	180	17.2	437	16.2	7.4	39	17.8	240
CG20400227-BXXXX	400	11.3	7.1	180	19.4	493	17.3	7.9	43	19.5	240
CG20450227-BXXXX	450	12.7	7.1	180	19.4	493	19.4	8.8	45	20.4	240
CG20500227-BXXXX	500	14.1	7.1	180	27.4	696	21.6	9.8	55	24.8	240
CG20550227-BXXXX	550	15.6	7.1	180	27.4	696	23.8	10.8	57	25.7	240
CG20600227-BXXXX	600	17.0	7.1	180	27.4	696	25.9	11.8	60	27.0	240
CG20650227-BXXXX	650	18.4	7.1	180	27.4	696	28.1	12.8	62	28.3	240
CG20700227-BXXXX	700	19.8	7.1	180	27.4	696	30.2	13.7	64	29.2	240
CG20750227-BXXXX	750	21.2	7.1	180	33.3	846	32.4	14.7	70	31.6	360
CG20800227-BXXXX	800	22.6	7.1	180	33.3	846	34.6	15.7	73	33.0	360
CG20850227-BXXXX	850	24.0	7.1	180	33.3	846	36.7	16.7	76	34.3	360
CG20900227-BXXXX	900	25.5	7.1	180	33.3	846	38.9	17.7	77	35.1	360
CG20950227-BXXXX	950	26.9	7.1	180	33.3	846	41.0	18.7	80	36.4	360
CG21000227-BXXXX	1000	28.3	10.0	254	21.4	544	43.2	19.6	93	42.2	360
MA20025227-BLXXX	25	0.7	3.3	85	9.5	241	1.1	0.5	5	2.4	240
MA20050227-BLXXX	50	1.4	3.3	85	13.3	338	2.2	1.0	8	3.7	240
MA20075227-BLXXX	75	2.1	4.3	110	15.6	396	3.2	1.5	13	6.0	240
MA20100227-BLXXX	100	2.8	4.3	110	15.6	396	4.3	2.0	14	6.4	240
MA20125227-BLXXX	125	3.5	4.3	110	15.6	396	5.4	2.5	15	6.9	240
MA20150227-BLXXX	150	4.3	5.1	130	17.2	436	6.5	2.9	20	9.2	240
MA20175227-BLXXX	175	4.9	5.1	130	17.2	436	7.6	3.4	21	9.6	240
MA20200227-BLXXX	200	5.7	5.1	130	17.2	436	8.6	3.9	22	10.0	240
MA20225227-BLXXX	225	6.4	6.3	160	17.3	439	9.7	4.4	29	13.2	240
MA20250227-BLXXX	250	7.0	6.3	160	17.3	439	10.8	4.9	30	13.6	240
MA20275227-BLXXX	275	7.8	6.3	160	17.3	439	11.9	5.4	31	14.1	240

Specifications Continued

Model Number	Volume Protected		Diameter		Total Height		Agent Weight		Shipping Weight		System Pressure (@70° F)
	ft ³	m ³	in	mm	in	mm	lbs	kgs	lbs	kgs	psi
MA20300227-BLXXX	300	8.5	6.3	160	17.3	439	13.0	5.9	32	14.5	240
MA20325227-BLXXX	325	9.2	7.1	180	17.2	437	14.0	6.4	37	16.9	240
MA20350227-BLXXX	350	10.0	7.1	180	17.2	437	15.1	6.9	38	17.4	240
MA20375227-BLXXX	375	10.6	7.1	180	17.2	437	16.2	7.4	39	17.8	240
MA20400227-BLXXX	400	11.3	7.1	180	19.4	493	17.3	7.9	43	19.5	240
MA20450227-BLXXX	450	12.7	7.1	180	19.4	493	19.4	8.8	45	20.4	240
MA20500227-BLXXX	500	14.1	7.1	180	27.4	696	21.6	9.8	55	24.8	240
MA20550227-BLXXX	550	15.6	7.1	180	27.4	696	23.8	10.8	57	25.7	240
MA20600227-BLXXX	600	17.0	7.1	180	27.4	696	25.9	11.8	60	27.0	240
MA20650227-BLXXX	650	18.4	7.1	180	27.4	696	28.1	12.8	62	28.3	240
MA20700227-BLXXX	700	19.8	7.1	180	27.4	696	30.2	13.7	64	29.2	240
MA20750227-BLXXX	750	21.2	7.1	180	33.3	846	32.4	14.7	70	31.6	360
MA20800227-BLXXX	800	22.6	7.1	180	33.3	846	34.5	15.6	73	33.0	360
MA20850227-BLXXX	850	24.0	7.1	180	33.3	846	36.7	16.7	76	34.3	360
MA20900227-BLXXX	900	25.5	7.1	180	33.3	846	38.9	17.7	77	35.1	360
MA20950227-BLXXX	950	26.9	7.1	180	33.3	846	41.0	18.7	80	36.4	360
MA21000227-BLXXX	1000	28.3	10.0	254	21.4	544	43.2	19.6	93	42.2	360
MA21050227-BLXXX	1050	29.7	10.0	254	21.4	544	45.3	20.5	96	43.5	360
MA21100227-BLXXX	1100	31.1	10.0	254	21.4	544	47.5	21.6	99	44.9	360
MA21150227-BLXXX	1150	33.0	10.0	254	27.5	699	49.7	22.6	108	49.0	360
MA21200227-BLXXX	1200	34.0	10.0	254	27.5	699	51.8	23.6	111	50.3	360
MA21250227-BLXXX	1250	35.4	10.0	254	27.5	699	54.0	24.5	113	51.3	360
MA21300227-BLXXX	1300	36.8	10.0	254	27.5	699	56.1	25.4	116	52.6	360
MA21350227-BLXXX	1350	38.2	10.0	254	27.5	699	58.3	26.5	119	54.0	360
MA21400227-BLXXX	1400	39.6	10.0	254	27.5	699	60.5	27.5	121	54.9	360
MA21450227-BLXXX	1450	41.0	10.0	254	27.5	699	62.6	28.5	124	56.2	360
MA21500227-BLXXX	1500	42.5	10.0	254	27.5	699	64.8	29.5	126	57.2	360
Low Profile Models											
CG20750227-B4XXX	750	21.2	10.0	254	21.4	544	32.4	14.7	80	36.3	360
CG20800227-B4XXX	800	22.6	10.0	254	21.4	544	34.5	15.6	83	37.6	360
CG20850227-B4XXX	850	24.0	10.0	254	21.4	544	36.7	16.7	86	39.0	360
CG20900227-B4XXX	900	25.5	10.0	254	21.4	544	38.9	17.7	88	39.9	360

Model Number	Volume Protected		Diameter		Total Height		Agent Weight		Shipping Weight		System Pressure (@70° F)
	ft ³	m ³	in	mm	in	mm	lbs	kgs	lbs	kgs	psi
CG20950227-B4XXX	950	26.9	10.0	254	21.4	544	41.0	18.7	91	41.3	360
MA20750227-BL4XX	750	21.2	10.0	254	21.4	544	32.4	14.7	80	36.3	360
MA20800227-BL4XX	800	22.6	10.0	254	21.4	544	34.5	15.6	83	37.6	360
MA20850227-BL4XX	850	24.0	10.0	254	21.4	544	36.7	16.7	86	39.0	360
MA20900227-BL4XX	900	25.5	10.0	254	21.4	544	38.9	17.7	88	39.9	360
MA20950227-BL4XX	950	26.9	10.0	254	21.4	544	41.0	18.7	91	41.3	360

All above models are approved under U.S.C.G. # 162.029/249/0, # 162.029/251/0.

When specifications listed on the label differ from this manual, the information listed on the label is correct.

240psi = 1655kPa = 16.5Bar

360psi = 2482kPa = 24.8Bar

Operation of Fireboy Fire Extinguisher

Manual operation of MA2XXXX227-BLXXX Systems

1. In case of fire, do not wait for automatic actuation.
2. Close all hatches leading to the protected compartment.
3. Shutdown all forced ventilation devices, engines, generators and electrical systems.
4. Remove the safety pin from the "FIRE" T-handle, and pull firmly.

Automatic operation of CG2XXXX227-BXXXX and MA2XXXX227-BLXXX systems

Actuation of a Fireboy fire extinguisher occurs at 175°F (79°C) and is entirely dependent on the intensity of the fire.

Signs of actuation

1. A loud sound similar to small arms fire.
2. A loud sound of rushing air.
3. The green indicator lamp is not illuminated.
4. A stalled engine.

When actuation occurs

1. Immediately shutdown all engines, powered ventilation, and electrical systems.
2. Extinguish all smoking materials.
3. Do not open the engine compartment.
4. The protected space may see an increase in pressure during discharge. Appropriate relief vents may be needed where structural integrity of protected space is in question.

Operation of Fireboy Fire Extinguisher Continued

After actuation

1. Before inspecting for damage, allow the agent to “soak” the compartment for at least 15 minutes and wait for hot metals or fuels to cool.
2. Have approved portable extinguishers in hand and ready for use.
3. Do not breathe fumes or vapors caused by the fire and/or suppression agent. They are hazardous and toxic. Refer to Health and Safety section (Page 23).
4. Forced ventilation will often be necessary. Care should be taken to readily dissipate hazardous atmospheres and not merely move them to another location. Consideration should be given to exhaust paths when opening or venting the enclosure after discharge. Ventilation should not be directed near any area that might be used as a gathering spot for personnel.

Marine Installation Instructions

Before Installation

1. Check the system for damage during shipment.
2. Check the pressure gauge to be sure the gauge pointer lies within the green zone at 70°F (21°C).
3. The correct weight is shown on the label for the appropriate model.
4. Select an interior location not directly subject to weather or seawater.
5. Confirm the volume of the compartment to be protected in cubic feet or cubic meters by multiplying the width, by the length, by the depth at the keel; make no deductions for installed equipment.
6. Verify calculated volume with volume shown on label and model specifications section.

Selecting a Location

1. Do not install a Fireboy system rated for less cubic volume than the volume of the compartment to be protected.
2. The maximum approved distance from the cylinder nozzle to ceiling is 20in (508mm).
3. Orientation:
 - Mounting up to 90° from vertical is permissible
 - Install on the forward or aft vertical bulkhead of the engine compartment as near to the centerline of the vessel (keel) as possible.
 - To prevent accelerated corrosion, do not mount directly to an aluminum/metal surface. Maintain galvanic isolation between the extinguisher and metal mounting surface.
 - Direct the actuator towards the opposite bulkhead or towards the engine(s)
 - Avoid installing athwart ship (perpendicular to the keel) on sailboats

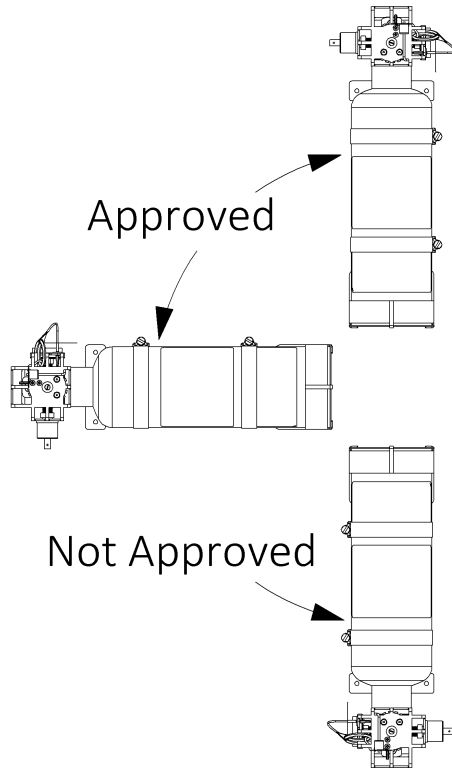

4. The approved ceiling height of the protected space is as follows:

- Models 025-300: 2.2ft (0.7m) to 6.3ft (1.9m)
- Models 325-700: 3.0ft (0.9m) to 7.0ft (2.1m)
- Models 750-1500: 4.0ft (1.2m) to 9.0ft (2.7m)

5. The maximum approved radial reach and area of coverage is as follows:

- Models 025-300: 10.6ft (3.2m), 89.3ft² (8.3m²)
- Models 325-700: 13.4ft (4.1m), 144ft² (13.4m²)
- Models 750-1500: 19.4ft (5.9m), 303ft² (28.1m²)

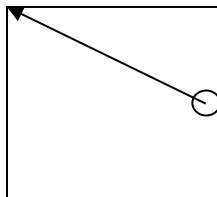

Mounting Fireboy system

DANGER:

ACCIDENTAL DISCHARGE DURING HANDLING OR INSTALLATION MAY CAUSE SERIOUS INJURY. DO NOT LIFT, CARRY, OR HANDLE BY ACTUATOR, PRESSURE SWITCH, OR CABLE. WEAR EYE PROTECTION WHEN INSTALLING OR SERVICING CYLINDER. REFER TO HEALTH AND SAFETY SECTION (PAGE 23).

Models 025-200

1. Use appropriate size and length bolts and lock washers and secure using all 4 mounting holes.
2. Mounting hardware can be installed with cylinder clamped in bracket.

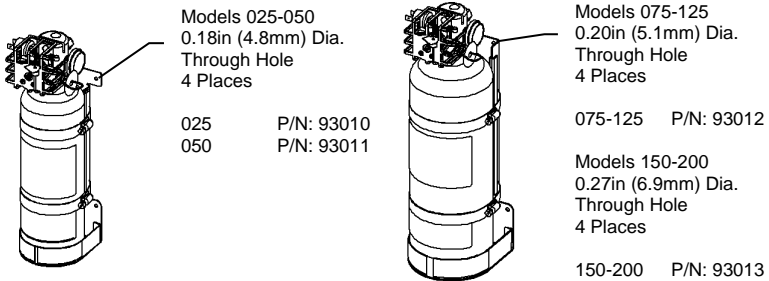

Models 225-700

1. Generously loosen cylinder clamps and remove cylinder.
2. Locate cylinder in safe and secure location to prevent cylinder from tipping.
3. Use appropriate size and length bolts and lock washers and secure bracket using all 6 mounting holes.
4. With bracket secured, place cylinder back in bracket and tighten cylinder clamps.

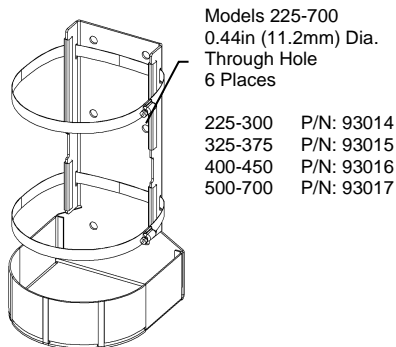

Models 750-1500

1. Use appropriate size and length bolts and lock washers and fasten to bulk head.
2. Mount the Shelf Brackets using the 6 mounting holes. Be sure to include unistrut while mounting bracket.
3. Locate upper bracket 1in (25.4mm) below the top weld seam of cylinder. Be sure to include spacer while mounting unistrut.
4. Install Clamps in unistrut and tighten with provided fasteners.

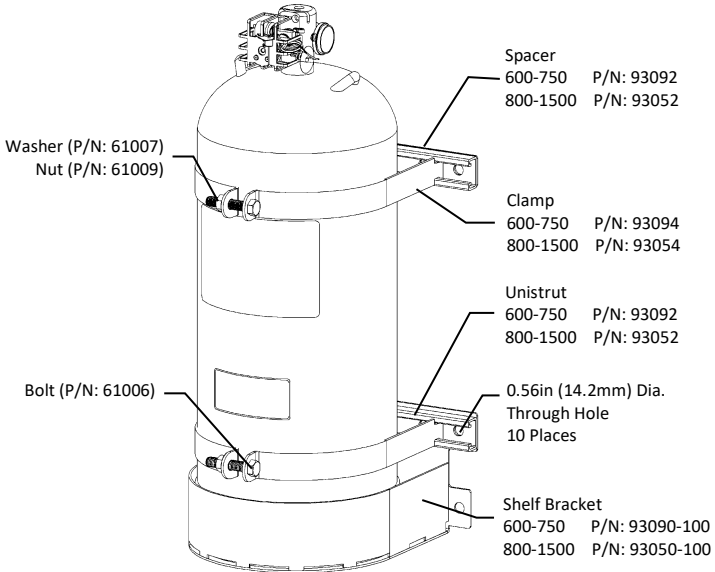

Cable Installation (P/N: E-4209-XXX, XXX = Length in Feet)

WARNING:

1. ALL FIREBOY MA2XXXX227-BLXXX SYSTEM INSTALLATIONS MUST USE ONLY GENUINE FIREBOY CABLES AND ASSOCIATED COMPONENTS THAT ARE ENGINEERED SPECIFICALLY FOR THIS APPLICATION. NOTHING ELSE WILL PROVIDE THE INTENDED DEGREE OF SAFETY AND RELIABILITY INHERENT IN THESE SYSTEMS.
2. ANY SUBSTITUTION WILL VOID ALL LABORATORY AND COAST GUARD APPROVALS AND FIREBOY-XINTEX WARRANTIES, AND MAY RESULT IN AN INOPERATIVE SYSTEM, AND UNSAFE AND HAZARDOUS CONDITIONS.
3. NEVER INSTALL A MANUAL RELEASE HANDLE IN THE SPACE TO BE PROTECTED.
4. NEVER INSTALL A CABLE ON A CG2XXXX227-BXXXX SERIES. FOR USE ON MA2XXXX227-BLXXX SERIES ONLY.

NOTE:

1. IF A DUAL RELEASE ADAPTER (DRA-1001) IS TO BE USED WITH THIS INSTALLATION, FOLLOW THE INSTRUCTIONS ENCLOSED WITH THAT UNIT AT THIS TIME.
2. FACTORY MUTUAL AND THE USCG REQUIRE MANUAL ACTUATION CABLES FOR ALL INSTALLATIONS OVER 1000 CU.FT.

CAUTION:

DO NOT CONNECT CABLE TO CYLINDER AT THIS TIME!

Routing the Cable

1. Locate the legend plate (1.9in (48mm) x 3.6in (92mm) with 7/16in (11.1mm) hole) for the manual release handle.
 - On a solid and secure surface (Minimum of ¼in (6.4mm) thick)
 - In full view of the operator
 - With enough clearance for the cable ferrule to extend approximately 12in (304.8mm) behind the panel
 - Angle Adaptor CAA-0285-01 available where clearance is limited
2. Using the legend plate as a template, locate and drill a 13/32in (10.3mm) hole.
3. Route the cable in the most direct manner, with as few bends as possible, to the cylinder location.
 - Do not bend in a radius of less than 6in (152.4mm) (a 12in (304.8mm) circle)
 - Follow the same route as manufacturer installed cables, if possible (Example: Steering, throttle, and transmission cables)
 - Do not subject cable to pinching or crushing, rubbing, extreme vibration, sharp bending or kinking, or extremes of heat or cold
 - Do not exceed 1440° of total bends (Example: 16 bends x 90° = 1440°)
 - Use the shortest allowable cable whenever possible
 - Maximum manual cable length is 100ft (30.5m)
4. Secure loose sections of the cable with the included nylon clamps.
 - Do not clamp cable in a bend
 - Do not crush cable with clamps

Legend Plate and T-Handle

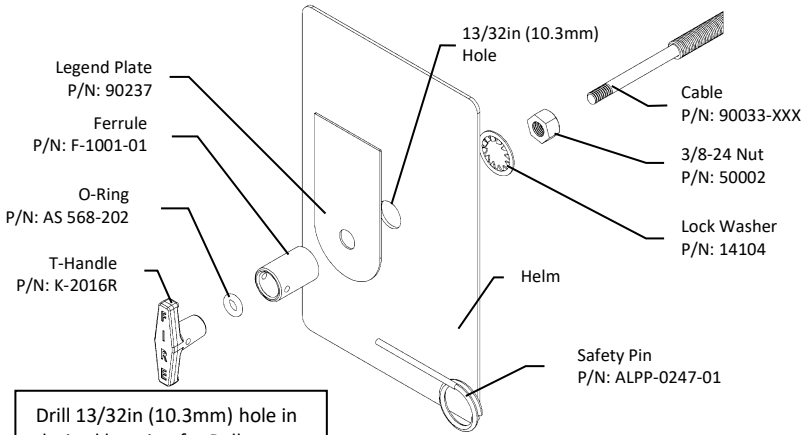

Drill 13/32in (10.3mm) hole in desired location for Pull Station.

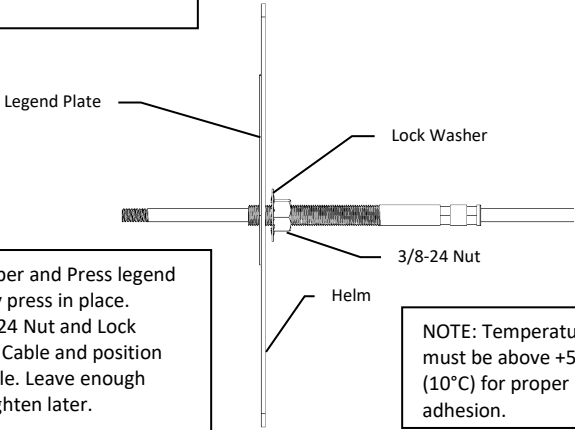

Peel off paper and Press legend plate firmly press in place. Install 3/8-24 Nut and Lock Washer on Cable and position through hole. Leave enough space to tighten later.

NOTE: Temperature must be above +50°F (10°C) for proper adhesion.

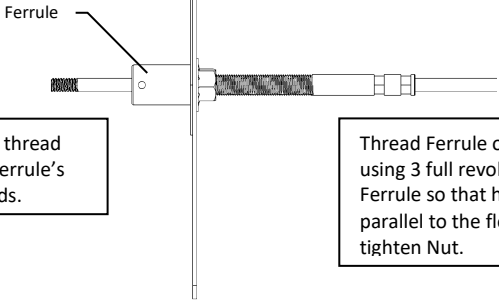

Note: Do NOT thread further than Ferrule's internal threads.

Thread Ferrule onto Cable using 3 full revolutions. Adjust Ferrule so that holes are parallel to the floor and tighten Nut.

Legend Plate and T-Handle Continued

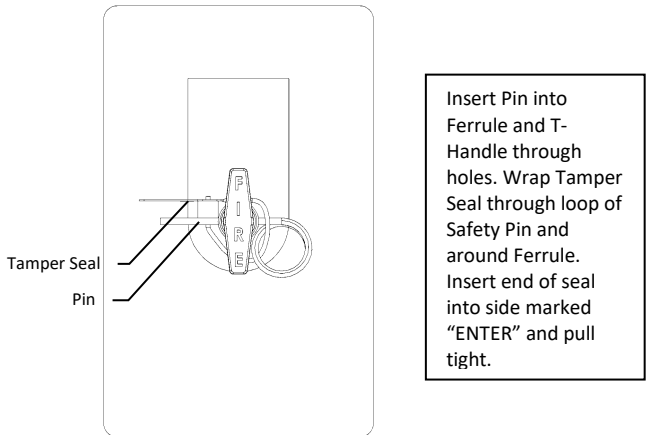
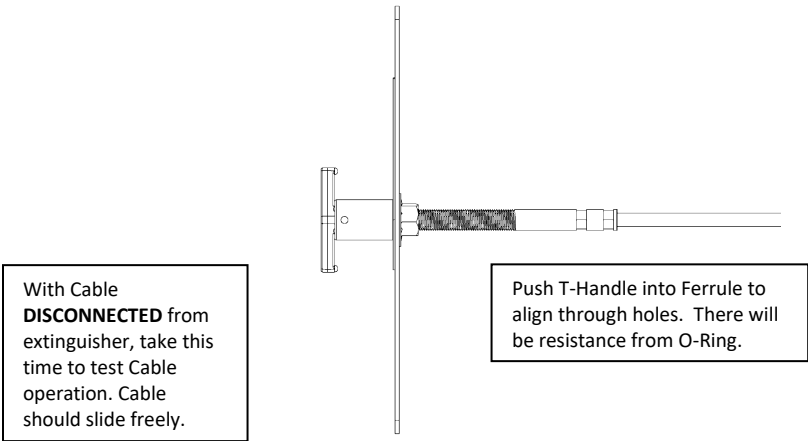
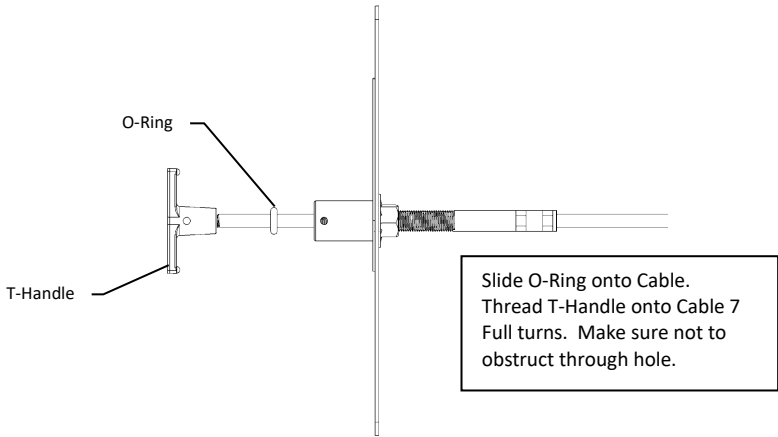

Connecting Cable to Cylinder

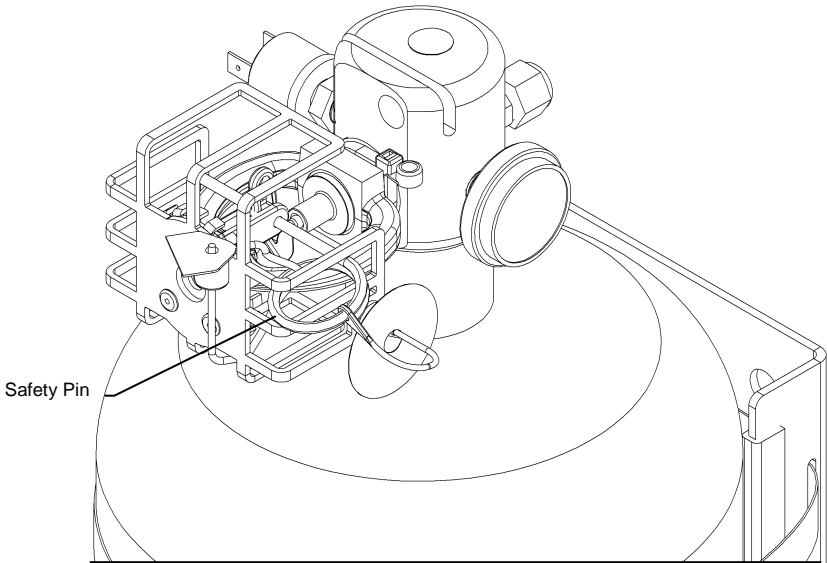

Extinguisher should be securely mounted and Cable should be routed.
Be sure the Safety Pin is in place.

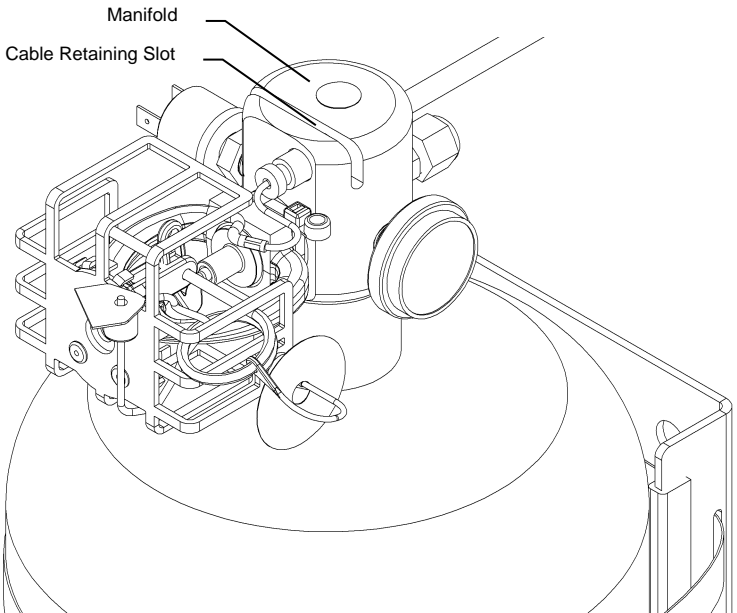

Insert extinguisher end of Cable through hole in Manifold past
retaining slot on Cable.

Connecting Cable to Cylinder Continued

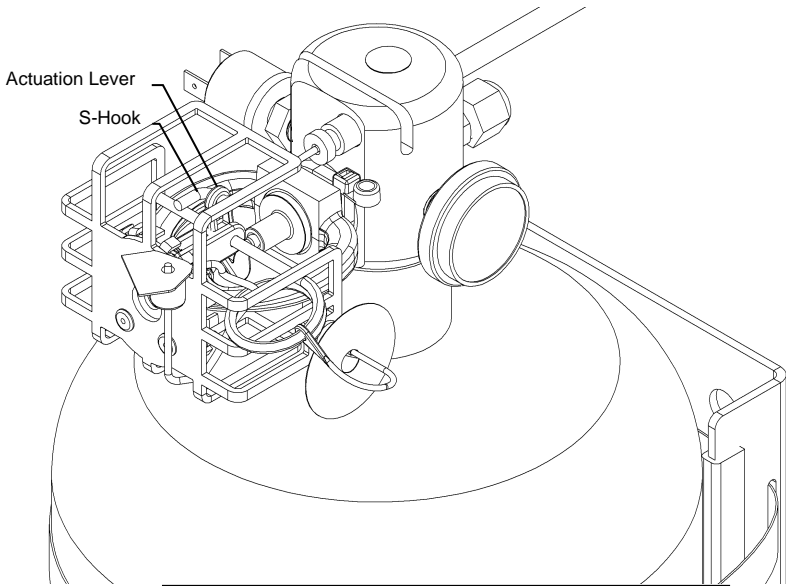

Insert S-Hook into hole at the top of Actuation Lever.

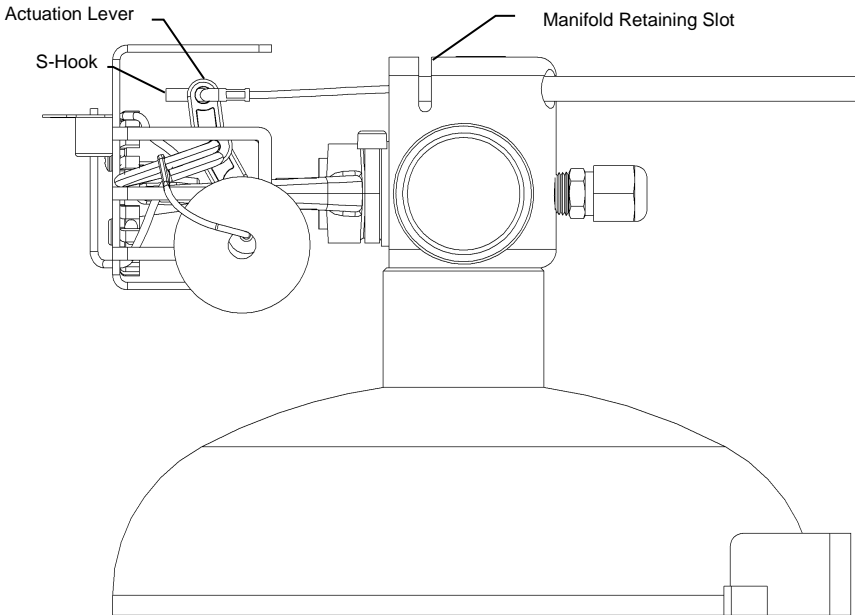

Align retaining slot of Cable with retaining slot of Manifold.

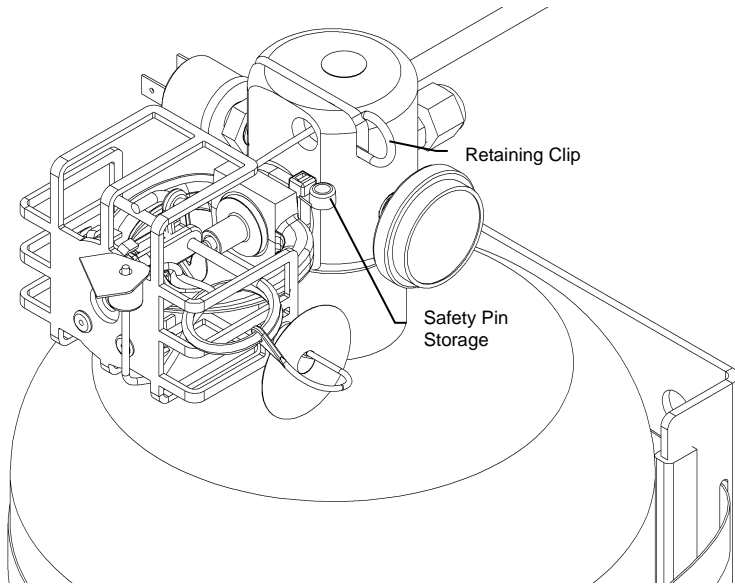

Secure Cable to Manifold with Retaining Clip.

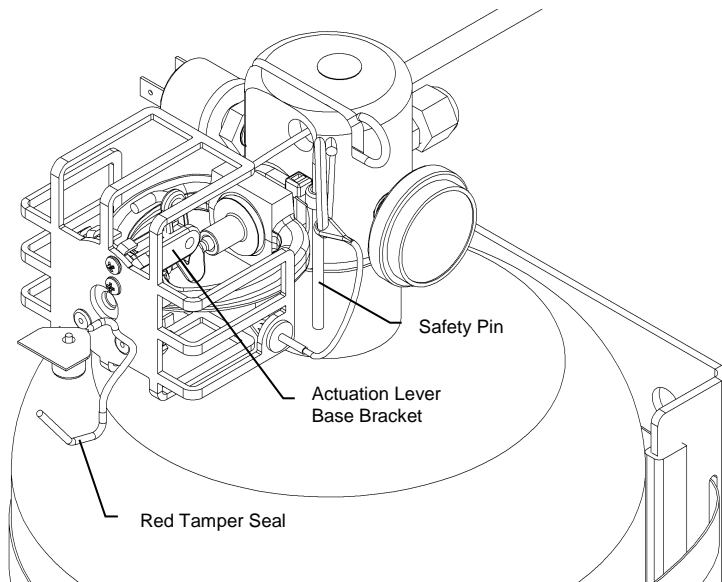

With T-Handle previously secured, remove Red Tamper Seal from Extinguisher to remove Safety Pin and store in provided location. Cable system is now operational.

WARNING:

FAILURE TO INSTALL AN ENGINE SHUTDOWN BOX WITH A FIREBOY SYSTEM IN ANY DIESEL ENGINE APPLICATION IMPEDES THE FIRE EXTINGUISHER AND MAY PREVENT FIRE EXTINGUISHMENT.

CAUTION:

FAILURE TO CONNECT A POWERED VENTILATION SYSTEM IN THE MANNER DESCRIBED BELOW IMPEDES FIRE EXTINGUISHER AND MAY PREVENT FIRE FROM BEING EXTINGUISHED.

1. Automatic Engine Shutdown units are available through your Fireboy-Xintex distributor, dealer or retailer in three, five, eight, and ten circuit models.
2. Follow the installation instructions included with the Automatic Engine Shutdown for proper installation.
3. Technical Support for Automatic Engine Shutdowns is available by calling Fireboy-Xintex or visiting our website at www.fireboy-xintex.com.

Installing Indicator Lamp (P/N: 90107)

Mounting Indicator Lamp

1. U.S. Coast Guard Rule 162.029 requires an indicator lamp and legend plate at each helm position from which the craft may be operated.
2. Your Fireboy System is supplied with one (1) indicator lamp and legend plate. Additional indicator lamps and legend plates are available factory direct, or through an authorized dealer.
3. Select an appropriate location for the indicator lamp and legend plate on or near the instrument panel at the helm and in full view of the operator.
4. Drill a 9/16in (14.3mm) hole.
5. Remove the backing paper on the legend plate.
6. Feed both wires through 9/16in (14.3mm) hole.
7. Press legend plate firmly press in place.

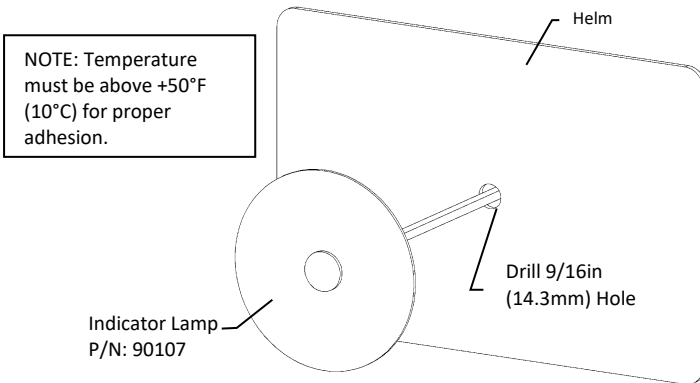

NOTE:

THE INDICATOR LAMP SUPPLIED IS FOR 12/24 VDC USE

WARNING:

1. AN ELECTRICAL SHORT MAY RESULT IN ELECTRICAL BURN, INJURY OR FIRE
2. BEFORE ATTEMPTING TO WIRE THE INDICATOR LAMP, TURN OFF ALL ELECTRICAL CURRENT TO THE IGNITION SWITCH
3. ALL FIREBOY WIRING MUST COMPLY WITH THE AMERICAN BOAT AND YACHT COUNCIL STANDARD E-11, TITLED AC AND DC ELECTRICAL SYSTEMS ON BOATS, AVAILABLE FROM ABYC, WWW.ABYCINC.ORG

Wiring Indicator Lamp

1. Review all wiring instructions below.
2. Consult a qualified marine electrician if you have any doubts about your ability to safely and properly complete the wiring. Ignition systems and electrical systems vary from boat to boat, and the directions which follow, may not apply to your boat.
3. Assemble the supplies you will need that are not included with your Fireboy System.
 - The necessary length of insulated 16 gauge (minimum) stranded wire
 - A one-half (0.5) ampere in-line fuse and fuse holder or circuit breaker
 - Properly sized insulated crimp-on wire connectors
4. Connect one lead of the fuse to the "ON" position of the starter switch.
5. Connect the other lead of the fuse to the red (+) wire of the LED indicator lamp.
6. Connect the black (-) wire of the indicator lamp to one of the pigtail wires on the Fireboy System (as shown below).
7. Do not reverse red and black wire, indicator lamp will not function.
8. Connect the remaining wire from the Fireboy system to ground.

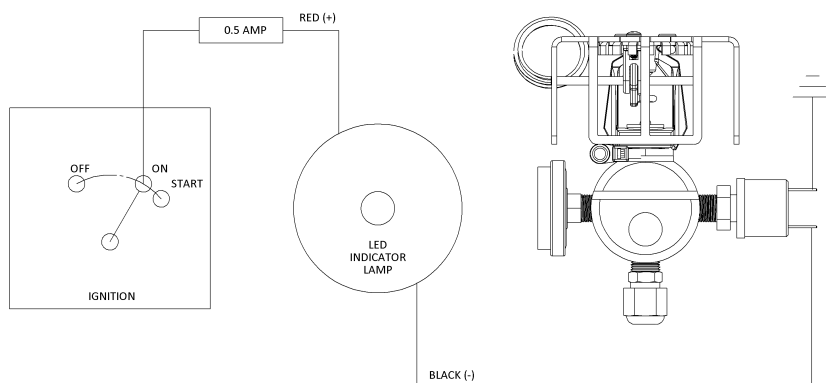

Connecting to Powered Ventilation

Engine compartments not equipped with a powered ventilation system require no further wiring.

If the engine compartment is equipped with a powered ventilation system, U.S. Coast Guard Rule 162.029 requires that the ground connection of the ventilation system be connected to the Fireboy system.

CAUTION:

FAILURE TO CONNECT A POWERED VENTILATION SYSTEM IN THE MANNER DESCRIBED BELOW IMPEDES FIRE EXTINGUISHER AND MAY PREVENT FIRE FROM BEING EXTINGUISHED.

Powered Ventilation Systems (Blowers)

1. Determine the maximum current draw of the powered ventilation system.
2. For current draw not exceeding 5 amps connect the negative (-) wire from the ventilation blower to the pressure switch at the same point as the indicator lamp.
3. For current draw exceeding 5 amps, use a Fireboy Automatic Engine Shutdown system.

NOTE:

THE LEGEND PLATE LED IS CONNECTED TO THE PRESSURE SWITCH AT THE SAME POINT THAT AUXILIARY DEVICES CAN BE CONNECTED. CARE MUST BE TAKEN WHEN WIRING OTHER DEVICES TO THE PRESSURE SWITCH TO ENSURE THE PRESENCE OF THE LED DOES NOT AFFECT THE OPERATION OF THE DEVICE. CONTACT FIREBOY-XINTEX TECHNICAL SUPPORT REGARDING ANY INSTALLATION QUESTIONS.

Use of indicator lamp

- The Fireboy System indicator lamp is designed to announce to the helmsman the state of the fire extinguisher when the ignition key is in the ON position.
- A GLOWING green light indicates the Fireboy system is CHARGED.
- A NON GLOWING light indicates the Fireboy system is DISCHARGED.

INSTALLATION CHECKLIST	
Verified Volume of Protected Space	
Verified Extinguisher Model is for Volume of Protected Space	
Mounted Extinguisher according to installation instructions	
Located extinguisher according to installation instructions	
Orientated extinguisher according to installation instructions	
Nozzle is no greater than 20in (508mm) from ceiling	
Secured Bracket according to installation instructions	
Installed Cable According to installation instructions (MA2XXXX227-BLXXX Series Only)	
Located Manual Release Handle according to installation instructions	
Routed Cable according to installation instructions	
No more than Sixteen 90° Bends (16 x 90° = 1440°)	
Secured Cable according to installation instructions	
Installed Manual Release Handle according to installation instructions	
Connected Cable to extinguisher according to installation instructions	
Removed Safety Pin on Extinguisher (System is operational)	
Installed Indicator Lamp According to installation instructions	
Located Indicator Lamp according to installation instructions	
Mounted Indicator Lamp according to installation instructions	
Wired Indicator Lamp according to installation instructions	
Review Maintenance of system	
Review Health and Safety Section of manual	
Installed Fireboy Automatic Engine Shutdown if required	

Maintaining Fireboy Fire Extinguisher

1. Inspect the pressure gauge and the system daily. Pointer must indicate in green zone at 70°F (21°C).
2. Compare actuator to illustration below to determine if the extinguisher is charged or discharged.

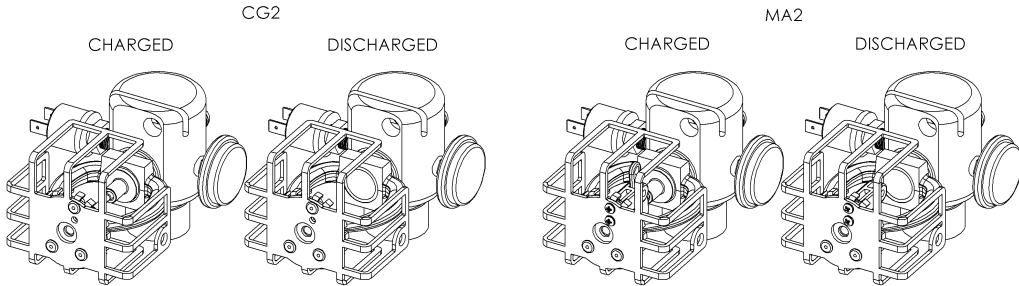

3. Remove and weigh the complete unit (without brackets) on a certified scale every six (6) months and record on tag provided.
4. Remove fire extinguisher from service immediately for repair or replacement if measured gross weight is greater than 5% below what is stated on unit's label (Label Gross Weight x 0.95 = Minimum Allowable Weight).
5. Inspect cylinder in accordance with CGA C-6, every 5 years OR have cylinder hydrostatic tested every 12 years.

Disconnection and Inspection of Manual Discharge Cable

DANGER:

ACCIDENTAL DISCHARGE DURING HANDLING, INSTALLATION OR INSPECTION MAY CAUSE SERIOUS INJURY. WEAR EYE PROTECTION WHEN INSTALLING OR SERVICING FIRE EXTINGUISHER OR DISCHARGE CABLE.

Inspect manual discharge cable annually when inspecting the fire extinguisher.

1. Do not remove the safety pin on the T-handle when disconnecting the manual discharge cable from the fire extinguisher manifold.
2. Carefully reinstall safety pin through actuation lever. Safety pin should secure actuation lever in actuation lever base. (See Page 17)
3. Remove the retaining clip securing the cable located at the slot in the top of the manifold. (See Page 17)
4. Carefully push the cable from the backside of the manifold towards the actuator far enough to allow the flexible center strand to bend.
5. Remove the "S" hook from the actuation lever.
6. Once the "S" hook is free of the actuation lever, pull the cable out and away from the manifold.

To reconnect the manual discharge cable to the cylinder, refer to "Connecting Cable to Cylinder" section of this manual.

Maintaining the Indicator Lamp Circuit

Should the indicator lamp fail to come ON when the ignition key is ON

1. Check the pressure gauge and actuator to see if the system has adequate pressure or has been discharged.
2. Check fuse.
3. Using a continuity tester, check the electrical pressure switch on the system bottle itself:
 - Pull the connectors off the spade terminals and place the probes of the continuity tester directly on the spade connectors
 - A closed circuit indicates a functioning pressure switch
4. Check the continuity of the remaining wiring circuit.
5. The indicator lamp is an LED (light emitting diode) and cannot be tested with a continuity tester. A simple method to test LED's is to remove the lamp and touch the Red wire to the + terminal and the black wire to the – terminal of an ordinary 9 volt battery.
6. Should the continuity of the pressure switch indicate an open circuit, the system will have to be returned to the factory for either replacement or repair, depending upon the model involved.

Health and Safety

- A properly designed and installed suppression system should not present any significant health or safety problems; however, there are basic precautions to be taken to avoid accidents, and aspects of the system operation that should be fully understood.
- HFC-227ea extinguishes fires by causing a cooling effect and by causing a chemical reaction with the combustion products and not by displacement of oxygen as is the extinguishment method of carbon dioxide. The agent therefore provides the ability to utilize the HFC-227ea system in occupied areas.
- HFC-227ea can decompose at high temperatures to form halogen acids. If so, their presence is readily detected as a sharp, pungent odor long before hazardous maximum exposure levels are reached.
- The noise created by the HFC-227ea agent discharging can be loud enough to startle people in the vicinity, but is unlikely to cause any permanent injury. Turbulence caused by high velocity discharge can dislodge substantial objects directly in its path, and cause enough general turbulence within the protected area to move paper and light objects.
- Direct contact with the vaporizing liquid discharged from an HFC-227ea nozzle has a cooling effect on objects and in extreme cases can cause frostbite to the skin. The liquid phase vaporizes rapidly when mixed with air and therefore limits the risk to the immediate vicinity of the nozzle. Reduction in visibility will occur due to the condensation of water vapor.

WARNING:

THE DISCHARGE OF CLEAN AGENT SYSTEMS TO EXTINGUISH A FIRE CAN RESULT IN A POTENTIAL HAZARD TO PERSONNEL FROM THE NATURAL FORM OF THE CLEAN AGENT OR FROM THE PRODUCTS OF COMBUSTION THAT RESULTS FROM EXPOSURE OF THE AGENT TO THE FIRE OR HOT SURFACES. TO AVOID SERIOUS PERSONAL INJURY, UNNECESSARY EXPOSURE OF PERSONNEL TO THESE POTENTIAL HAZARDS MUST BE AVOIDED.

HMIS: 2-0-0/HEPTAFLUOROPROPANE/CONTENTS UNDER PRESSURE. 0-0-0/NITROGEN EXPELLANT GAS/VERY COLD, CONTENTS UNDER PRESSURE. CONSULT CHEMOURS, 1007 MARKET STREET, WILMINGTON, DE 19898; MEDICAL EMERGENCY PHONE 800-441-3637 (OUTSIDE THE U.S. 1-302-774-1139).

First Aid

- Skin** Maintain at body temperature, thaw affected area with gentle heat. If frostbite occurs, seek medical assistance. Do not rub affected area.
- Eyes** Apply gentle heat. Do not allow patient to touch affected area, seek medical assistance.

For more information on HFC-227ea, please see the SDS on page 26.

DANGER:

1. DO NOT HANDLE BY ACTUATOR
2. DO NOT DROP
3. KEEP AWAY FROM CHILDREN
4. KEEP AWAY FROM EXTREME HEAT
5. DO NOT DISCHARGE ANY FIREBOY AUTOMATIC OR MANUAL/AUTOMATIC SYSTEM UNLESS SECURELY FASTENED IN ACCORDANCE WITH THE OWNER'S MANUAL
6. NEVER ATTEMPT TO MANUALLY DISCHARGE A CG2XXXX227-BXXXX FIREBOY SYSTEM
7. NEVER ATTEMPT TO DISASSEMBLE ANY COMPONENT OF THIS SYSTEM
8. ALWAYS WEAR EYE, FACE AND BODY PROTECTION WHEN INSTALLING, REMOVING OR WORKING IN THE IMMEDIATE VICINITY OF THIS SYSTEM

Principle health hazards

- Death without warning if high concentrations are inhaled
- Reduced oxygen available for breathing
- Frostbite from direct exposure
- Increased susceptibility to the toxicity of excess exposure for individuals with pre-existing diseases of the central nervous system, cardiovascular system, lungs or kidneys
- Toxic by-products are produced when this agent extinguishes fire

Medical instructions

- If high concentrations are inhaled, immediately move the exposed to fresh air and keep calm
- If not breathing, give artificial respiration. Seek medical assistance
- If breathing is difficult give oxygen. Seek medical assistance
- In case of skin contact immediately flush skin with water for 15 minutes
- Treat for frostbite if necessary by gently warming affected area. Seek medical assistance if irritation is present
- In case of eye contact, immediately flush eyes with plenty of water for at least 15 minutes. Seek medical assistance
- Wash contaminated clothing before reuse

Fireboy FM Component Approved HFC-227ea Systems contain Heptafluoropropane. Heptafluoropropane has been accepted by the EPA and EU as a suitable alternate to Halon. None of the components in these materials are listed by IARC, NPT, OSHA or ACGIH as a carcinogen.

Additional Equipment

Coast Guard Regulation 162.029 requires an indicator lamp be installed at each helm station from which the vessel may be operated.

An Automatic Discharge Alarm provides both an audible and visual alarm when the system discharges. Includes a 2in (50.8mm) round instrument with a simple three (3) wire hookup.

Automatic Engine Shutdown/Override System is required for use with Fireboy systems in diesel powered craft.

These additional equipment options are available factory direct or through your dealer. Outside the U.S.A. and Canada, see your dealer.

SECTION 1. IDENTIFICATION

Product identifier: HFC-227ea (Fire extinguishing agent)
 Trade Name/Synonym: Heptafluoropropane, FM-200
 Product Use: Fire extinguishing agent
 Manufacturer/Supplier: Fireboy-Xintex LLC Fireboy-Xintex UK Operations Limited
 O-379 Lake Michigan Dr. Unit 10 Holton, Holton Ind. Estates
 Grand Rapids, MI 49534 Poole Dorset BH16 6LT UK
 1-616-735-9380 44 (0) 845 9462

SECTION 2. HAZARDS IDENTIFICATION

OSHA/HCS status: This material is considered hazardous by OSHA Hazard Communication Standard (29 CFR 1910.1200)

Classification of substance or mixture: Gases under Pressure

GHS label elements:

Hazard Pictograms:



Signal word:

Warning

Hazard statements:

H280: Contains gas under pressure; may explode if heated
 P210: Keep away from heat/spark/open flame. – No smoking
 P233: Keep container tightly closed in a cool/well-ventilated place
 P260: Do not breathe dust/fumes/gas/vapors/spray
 P273: Avoid release to the environment
 P280: Wear protective gloves/protective clothing/eye protection/face protection
 P403: Use and store only in a well-ventilated area
 Other Hazards: May cause frostbite
 May displace oxygen and cause rapid suffocation
 Overheating and over pressurizing may cause gas release or violent cylinder bursting

SECTION 3. COMPOSITION/INFORMATION ON INGREDIENTS

Component	CAS-No.	Concentration
1,1,1,2,3,3,3-Heptafluoropropane	431-89-0	100%

SECTION 4. FIRST AID MEASURES

Skin contact:	In case of contact, immediately flush skin with plenty of water for at least 15 minutes. Take off all contaminated clothing immediately. Consult a physician. Wash contaminated clothing before re-use. Treat for frostbite if necessary by gently warming affected area.
Eye contact:	In case of contact, immediately flush eyes with plenty of water for at least 15 minutes. Consult a physician if necessary.
Inhalation:	Move to fresh air, lie down. Keep patient warm and at rest. Artificial respiration and/or oxygen may be necessary. Consult a physician.
Ingestion:	Is not considered a potential route of exposure.
General advice:	Never give anything by mouth to an unconscious person. When symptoms persist or in all cases of doubt seek medical advice.
Notes to physician:	Because of possible disturbances of cardiac rhythm, catecholamine drugs, such as epinephrine, that may be used in situations of emergency life support should be used with special caution.

SECTION 5. FIREFIGHTING MEASURES

Fire and Explosion Hazard:	The product is not flammable. Hazardous decomposition products: Hydrogen fluoride, Carbonyl fluoride
Suitable extinguishing media:	This material is a fire extinguishing agent.
Notes to fire-fighters:	Wear full protective clothing, including helmet, self-contained breathing apparatus, protective clothing, and face mask. Use water to cool fire-exposed containers.

SECTION 6. ACCIDENTAL RELEASE MEASURES

NOTE:	Review FIRE FIGHTING MEASURES and HANDLING (PERSONNEL) sections before proceeding with clean-up. Use appropriate PERSONAL PROTECTIVE EQUIPMENT during clean-up.
Safeguards (Personnel):	Evacuate personnel, thoroughly ventilate area, and use self-contained breathing apparatus. Keep upwind of leak – evacuate until gas has dispersed.
Spill Cleanup:	Ventilate area using forced ventilation, especially low or enclosed places where heavy vapors might collect.

SECTION 7. HANDLING AND STORAGE

Handling (Personnel):	Do not breathe gas. Avoid contact with skin, eyes and clothing. Provide sufficient air exchange and/or exhaust in work rooms. For personal protection see section 8. Wash hands thoroughly after handling. Wash clothing after use. Decomposition will occur when product comes in contact with open flame or electrical heating elements. Handle in accordance with good industrial hygiene and safety practice.
-----------------------	---

Storage: Valve protection caps and valve outlet threaded plugs must remain in place unless container is secured with valve outlet piped to use point. Do not drag, slide or roll cylinders. Never attempt to lift cylinder by its cap. Cylinders should be stored upright and firmly secured to prevent falling or being knocked over. Keep at temperature not exceeding 130°F (54°C). Do not store near combustible materials. Keep container tightly closed in a dry and well-ventilated place. Store in original container. Protect from contamination. Avoid area where salt or other corrosive materials are present.

Storage temperature: 32°F (0°C) to 130°F (< 54°C)

SECTION 8. EXPOSURE CONTROLS/PERSONAL PROTECTION

Engineering controls: Use only with adequate ventilation. Keep container tightly closed.

Personal protective equipment

Respiratory protection: appropriate. Wear NIOSH approved respiratory protection as

Hand protection:

Eye protection: Additional protection: Impervious gloves
Safety glasses with side-shields, additionally wear a face shield where the possibility exists for face contact due to splashing, spraying or airborne contact with this material.

Skin and body protection: Where there is potential for skin contact, have available and wear as appropriate, impervious gloves, apron, pants, jacket, hood and boots.

Protective measures: Self-contained breathing apparatus (SCBA) is required if a large release occurs.

Exposure Guidelines

Exposure Limit Values Not Established.

SECTION 9. PHYSICAL AND CHEMICAL PROPERTIES

Form: Clear liquefied gas

Odor: none

Boiling point: -16.3°C (2.7°F)

Vapor Pressure: 4,547hPa at 25°C (77°F)

Density: 1.388g/cm³ at 25°C (77°F) (as liquid)

SECTION 10. STABILITY AND REACTIVITY

Stability:	Stable at normal temperatures and storage conditions.
Incompatibility:	Alkali metals Alkaline earth metals, powdered metals, powdered metal salts
Hazardous Decomposition Products:	Hydrogen fluoride, Carbonyl fluoride, Carbon monoxide, Carbon dioxide
Hazardous reactions:	Polymerization will not occur.

SECTION 11. TOXICOLOGICAL INFORMATION

Inhalation 4 h LC50:	> 788698ppm, rat
Inhalation:	dog Cardiac sensitization
Dermal:	not applicable
Oral:	not applicable
Skin irritation:	No skin irritation, not tested on animals Not expected to cause skin irritation based on expert review of the properties of the substance.
Eye irritation:	No eye irritation, not tested on animals Not expected to cause eye irritation based on expert review of the properties of the substance.
Sensitization:	Does not cause skin sensitization, not tested on animals Not expected to cause sensitization based on expert review of the properties of the substance. Did not cause sensitization on laboratory animals. There are no reports of human respiratory sensitization.
Repeated dose toxicity:	Inhalation, rat, No toxicologically significant effects were found.
Carcinogenicity:	Overall weight of evidence indicates that the substance is not carcinogenic.
Mutagenicity:	Did not cause genetic damage in animals. Did not cause genetic damage in cultured mammalian cells. Did not cause genetic damage in cultured bacterial cells.
Reproductive toxicity:	Animal testing showed no reproductive toxicity. Information given is based on data obtained from similar substances.
Teratogenicity:	Animal testing showed no developmental toxicity.
Further information:	Cardiac sensitization threshold limit: 730190 mg/m3

SECTION 12. ECOLOGICAL INFORMATION

Aquatic Toxicity

96 h LC50:	Danio rerio (zebra fish) > 200mg/l Information given is based on data obtained from similar substances.
96 h LC50:	Oncorhynchus mykiss (rainbow trout) > 81.8mg/l Information given is based on data obtained from similar substances.
72 h EC50:	Pseudokirchneriella subcapitata > 114mg/l Information given is based on data obtained from similar substances.
72 h EC50:	Pseudokirchneriella subcapitata > 118mg/l Information given is based on data obtained from similar substances.
48 h EC50:	Daphnia magna (Water flea) > 200mg/l Information given is based on data obtained from similar substances.
48 h EC50:	Daphnia magna (Water flea) > 97.9mg/l Information given is based on data obtained from similar substances.

Environmental Fate

Biodegradability aerobic:	1% OECD Test Guideline 301, not readily biodegradable.
Biodegradability aerobic:	5% OECD Test Guideline 301, not readily biodegradable.

SECTION 13. DISPOSAL CONSIDERATIONS

Waste Disposal:	Can be used after re-conditioning. Recover by distillation or remove to a permitted waste disposal facility. Comply with applicable Federal, State/Provincial and Local Regulations.
Environmental Hazards:	Empty pressure vessels should be returned to the supplier.

SECTION 14. TRANSPORT INFORMATION

DOT	UN number:	3296
	Proper shipping name:	Heptafluoropropane
	Class:	2.2 (Non-Flammable Gas)
IATA_C	Labelling No. :	2.2
	UN number:	3296
	Proper shipping name:	Heptafluoropropane
IMDG	Class:	2.2 (Non-Flammable Gas)
	Labelling No. :	2.2
	UN number:	3296
	Proper shipping name:	Heptafluoropropane
	Class:	2.2 (Non-Flammable Gas)
	Labelling No. :	2.2

Or – If packaged as a charged Fire Extinguisher...

DOT	UN number:	1044
	Proper shipping name:	Fire Extinguishers
	Class:	2.2 (Non-Flammable Gas)
	Labelling No. :	2.2
IATA_C	UN number:	1044
	Proper shipping name:	Fire Extinguishers
	Class:	2.2 (Non-Flammable Gas)
	Labelling No. :	2.2
IMDG	UN number:	1044
	Proper shipping name:	Fire Extinguishers
	Class:	2.2 (Non-Flammable Gas)
	Labelling No. :	2.2

SECTION 15. REGULATORY INFORMATION

SARA 313 Regulated

Chemical(s): SARA 313: This material does not contain any chemical components with known CAS numbers that exceed the threshold (De Minimis) reporting levels established by SARA Title III, Section 313.

California Prop. 65: Chemicals known to the State of California to cause cancer, birth defects or any other harm: none known

SECTION 16. OTHER INFORMATION

HMIS

Health:	1
Flammability:	0
Reactivity/Physical hazard:	0
PPE:	Personal Protection rating to be supplied by user depending on use conditions.

The information provided in this Safety Data Sheet is correct to the best of our knowledge, information and belief at the date of its publication. The information given is designed only as a guidance for safe handling, use, processing, storage, transportation, disposal and release and is not to be considered a warranty or quality specification. The information relates only to the specific material designated and may not be valid for such material used in combination with any other materials or in any process, unless specified in the text.

Revision: December 21, 2015

May 9, 2016

January 27, 2017

Returning Fireboy-Xintex Equipment

No product may be returned for credit or repair without a written “Returned Material Authorization” (RMA) form. Purchaser must call or email Fireboy-Xintex 616-735-9380 or fireboy@fireboy-xintex.com for a RMA. If due to extenuating circumstances a product is to be returned, after approval it must be received in 100% new/resalable condition. Products stored by the buyer for more than 26 weeks may not be returned for any reason. Maintaining fresh and current inventory is the responsibility of the buyer.

Recharging Fireboy Extinguishers

Fireboy-Xintex cylinders comply with DOT specification 4B/240, 4B/360, and 4BW/360 which allows for recharging as long as the extinguisher was not discharged due to a fire and passes visual inspection in accordance with CGA C-6, or a hydrostatic test. Extinguisher cannot be recharged or refilled in the field. Contact manufacturer for details on the recharging process.

3 Year Limited Warranty

This Warranty is in lieu of all other expressed or implied Warranties

Seller warrants title, materials, and workmanship on equipment, except components manufactured by others for which the Seller assigns, as permitted, the original manufacturer's warranty. Seller's warranty shall be for a period of (3) three years from the date of sale to the ORIGINAL CONSUMER PURCHASER, during which non-conforming equipment returned to the Seller at Buyer's expense and risk, be repaired or replaced at the Seller's option. Fireboy-Xintex LLC will repair or replace products found to be defective in materials or workmanship within the period set forth above, provided that: (a) the product has not been subjected to abuse, contamination, neglect, accident, incorrect wiring not our own, improper installation or servicing, or used in violation of instructions furnished by Fireboy-Xintex LLC and (b) as to any prior defects in materials or workmanship covered by this warranty, the product has not been repaired or altered by anyone except Fireboy-Xintex LLC and (c) the serial number has not been removed, defaced or otherwise changed, and (d) examination discloses, in the judgment of Fireboy-Xintex LLC, does not assume the costs of removal and/or installation of the product or any other incidental costs of removal and/or installation of the product or any other incidental costs which may arise as a result of any defect in material or workmanship, and (e) upon discovery of defect, Buyer shall immediately cease use of and notify Fireboy-Xintex LLC.

Any warranty implied by law, including warranties of merchantability or fitness, is in effect only for the duration of the expressed warranties set forth above, no person is authorized to give any other warranty, or to assume for Fireboy-Xintex LLC any other liability in connection with the sale of its products; Fireboy-Xintex LLC shall not be liable for the loss of use, revenue, or profit or for any injury, or for any other consequential or incidental damages, buyer is not relying on seller's judgment regarding his or her particular requirements, and has had an opportunity to inspect the product to his or her satisfaction.

This warranty gives you specific legal rights, and you may also have other rights, which vary, from state to state.

www.fireboy-xintex.com

Fireboy-Xintex LLC
O-379 Lake Michigan Dr. NW
Grand Rapids, MI 49534
fireboy@fireboy-xintex.com
Phone (616) 735 9380

Fireboy-Xintex UK Operations Limited
10 Holton Road, Holton Heath Trading Park
Poole Dorset BH16 6LT UK
fireboyeu@fireboy-xintex.com
Phone 44 (0) 845 9462