

4942 Austin Park Drive  
 Buford, GA 30518  
 (678) 288-9678



## MWL-TS Bar Light

### Features:

1. Designed for harsh environments.
2. Anodized aluminum body.
3. Tempered glass lens.
4. IP67 rating to withstand High pressure wash downs, coolants and detergents.
5. Advanced LED technology provides 85 LM/W.
6. Adjustable bracket. 90 Degrees rotation.

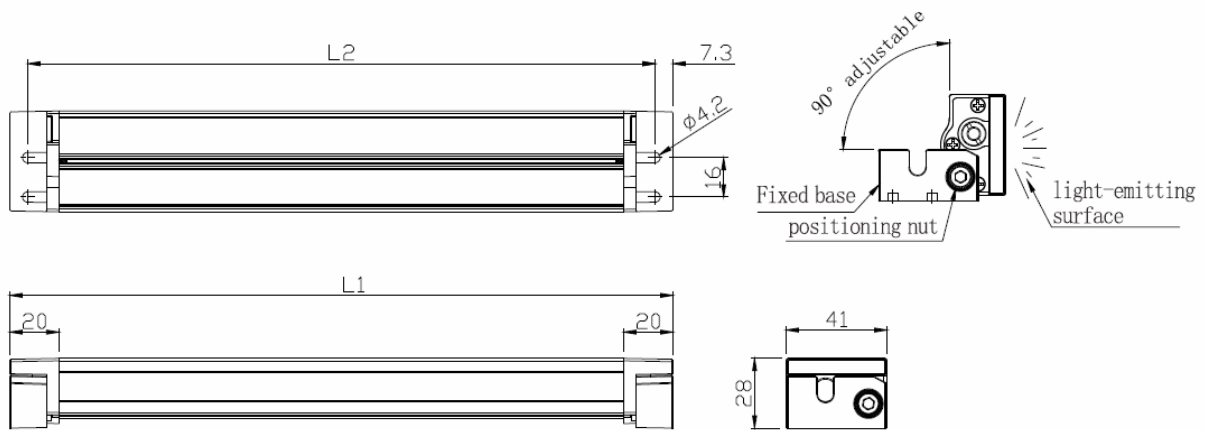

<b>L1</b>	<b>280</b>	<b>380</b>	<b>480</b>	<b>580</b>
<b>L2</b>	<b>262 ± 3</b>	<b>362 ± 3</b>	<b>462 ± 3</b>	<b>562 ± 3</b>

### Specifications:

Certification – CE, RoHS

Power – 8W (280mm), 12W (380mm), 16W (480mm), 18W, (580mm)

Lumens - 680lm (280mm), 1020lm (380mm), 1360lm (480mm), 1530lm (580mm)

Lumen Efficiency – 85lm/W

CRI >80

IP Rating – IP67

Color 6000-6500K

Material - Aluminum Housing, Tempered Glass Lens

Estimated Life – 50,000 hours

Working Temp / Humidity -20-45 Celsius / 10%-90%

Installation Type – screw Mount