

S30

Perfect Touch

WELCOME
to the TOUCH
REVOLUTION

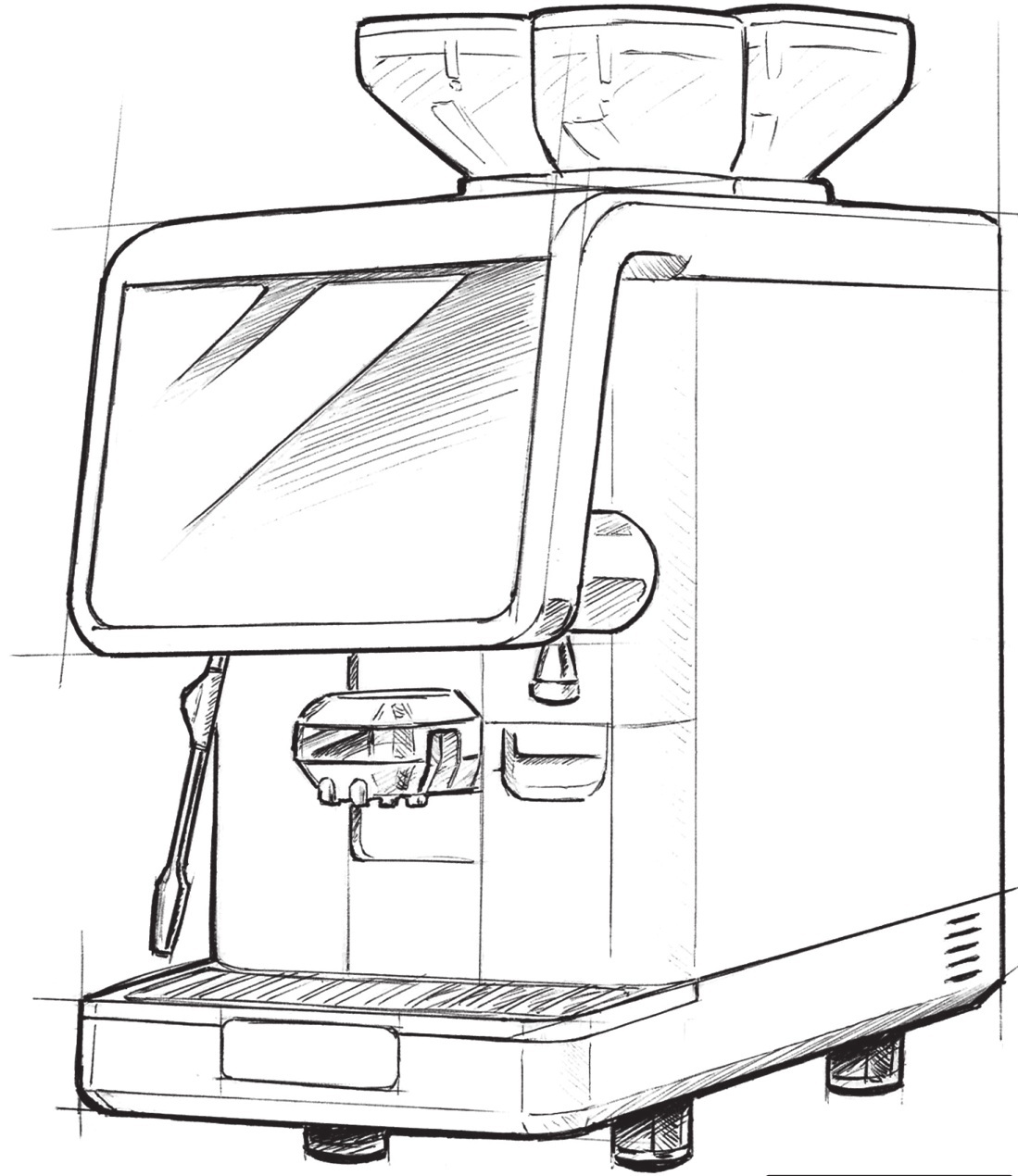

QUICK START GUIDE

USA

LA **CIMBALI**

www.cimbali.com

946-303-010 (1921) QUICK



This manual is a **QUICK START GUIDE** which contains the main instructions for using the machine.
The complete version of the Usage and Installation Manual is available on the machine, under the **DOCUMENTATION** section of **CUSTOMER PROGRAMMING** ⁽¹⁾, or on the website indicated at the bottom of the page ⁽²⁾, using the login details given below, where you can consult and download the required file.

(1)

CUSTOMER PROGRAMMING

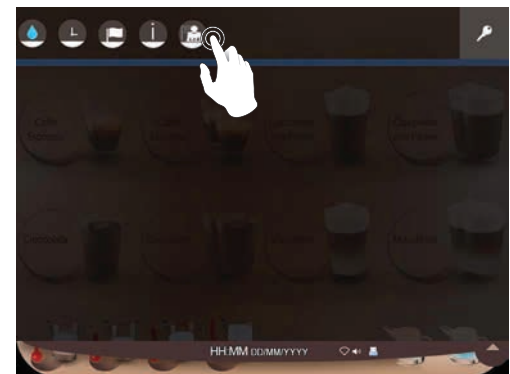

⁽²⁾ <https://order.gruppocimbali.com/explorer/spareparts/page/login>
User ID: guest
PW: Entr@nc3



Please sign in

Sign in

Index

	Page		Page		Page
1. General Rules	5				
2.1 Transport and handling.....	6				
2.2 Installation Rules.....	7				
3. Electrical Installation Rules.....	8				
4. Water Installation Rules.....	9				
5. Installation Check-up.....	10				
6. Operator instructions.....	11				
7. Warnings.....	13				
8. Maintenance and repair	14				
9. Dismantling the machine.....	15				
		USE			
		10. Daily operation.....	16		
		11. Description of display symbols.....	18		
		12. Beverage dispensing - Coffee - Cappuccino / milk - Chocolate/solubles	19		
		13. Beverage dispensing - Coffee / Cappuccino with powdered coffee ...	20		
		14. Beverage dispensing - Hot water	23		
		15. Beverage dispensing - Steam	24		
		16. Cleaning and maintenance	25		
		Complete wash	26		
		In place cleaning: cleaning the milk circuit (where present)	28		
		In place cleaning: cleaning the mixer (where present)	29		
		Cleaning the solubles circuit	32		
		Touch screen	33		
		Grounds drawer	33		
		Cup tray	34		
		Decaffeinated door	34		
		Bodywork	34		
		Cleaning the coffee hopper	35		
		17. Diagnostics messages	36		
		18. Defects - Malfunctions	38		
				CUSTOMER PROGRAMMING	
				DATE AND TIME	39
				LANGUAGE	39
				ILLUSTRATIONS.....	40
				SERVICE LINE	40

S30

English



LEGEND

- 1 Dispensing nozzle coffee/ cappuccino/solubles
- 2 Grounds drawer
- 3 Hot water outlet
- 4 Touch screen
- 5 Decaffeinated coffee panel
- 6 Soluble / coffee * hopper
- 6a Coffee hopper 2
- 6b Coffee hopper 1
- 7 "Sleep mode" led
- 8 "Sleep mode" button
- 9 Main switch
- 10 Steam pipe/Turbosteam pipe *
- 11 Tray
- 12 Control panel lock
- RGB Machine lighting
- USB USB Port

The components (*) are applied only in some product configurations

	P_{max} [psi]	T_{max} [°F]	Type of machine	S30
			Fluid	Capacity [L]
Service boiler	36	271	water/steam	1.3
Coffee boiler	174	271	water	0.7

	POWER SUPPLY	INSTALLED POWER	LINE POWER	SUPPLY CABLE SECTION
Machine	208-240V 60Hz	4,4 - 5,9 kW	25A (plug 50A)	min. 3 x 2.5 mm ² (12/3 AWG)

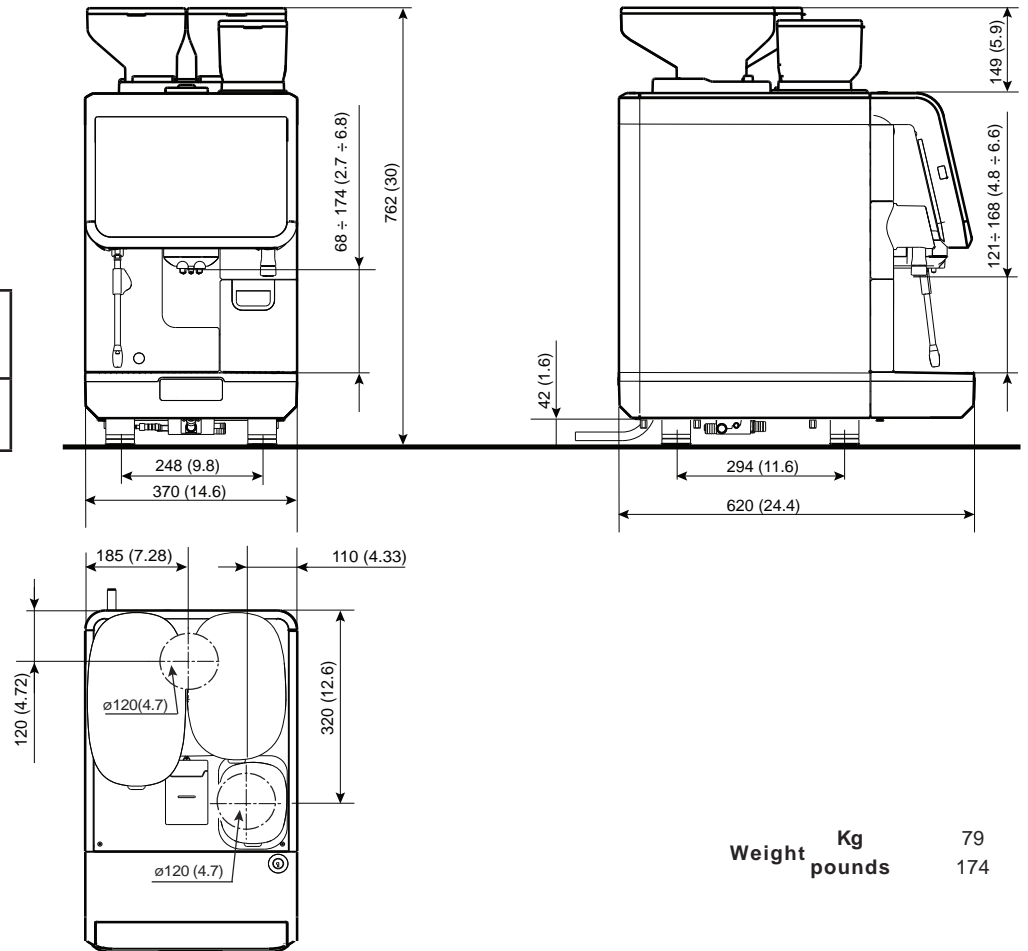

Weight **Kg** 79
pounds 174

Symbols



Generic warning



WARNING: Electrical Hazard



WARNING: Trapping Hazard, Take Care with Hands



WARNING: Hot surface



Environmental protection



These pages of the manual are for the use of the worker operating the machine.



These pages in the manual are to be used by qualified, authorized technical staff.



1. General Rules



Please read the warnings and rules in this User's Manual carefully before using or handling the machine in any way because they provide important information regarding safety and hygiene when operating the machine.

Keep this booklet handy for easy reference.

- The machine was designed solely for preparing espresso coffee and hot beverages using hot water or steam. Any other use is considered irregular.
- The machine must be installed in a place where it is only used by carefully trained staff that knows the risks tied to using the machine.
- The machine is for professional use only.
- This appliance can be used by children aged from 8 years and above and persons with reduced physical, sensory or mental capabilities or lack of experience and knowledge if they have been given supervision or instruction concerning use of the appliance in a safe way and understand the hazards involved.
Children shall not play with the appliance.
Cleaning and user maintenance shall not be made by children without supervision.
Use by minors, with or without adult supervision, must not contravene local employment laws.
- Never leave the machine unattended while it is in use.
- The machine must not be used outdoors.
- If the machine is stored in rooms where the temperature can drop below freezing point, empty the boiler and water circuit tubes.
- Do not expose the machine to atmospheric agents (rain, sun, and cold).
- Do not clean the machine with jets of water.
- Noise: assessed acoustic pressure level 75 dB(A) (+/- 2.5dB).
- If the power-supply cord is damaged, it can only be replaced by qualified and authorized technicians.
- If the machine is used improperly or for purposes other than those described above, it can be a source of danger. The manufacturer will not be held responsible for damages caused by improper use of the machine.



WARNING

Installation, dismantling, and adjustments must only be performed by qualified and authorized technicians.

Carefully read the warnings and rules in this manual because they provide important information regarding safe installation, use and maintenance of the machine.

Keep this booklet handy for easy reference.

2.1 Transport and handling

Packaging

- The machine is delivered in a robust cardboard package, with appropriate internal protection. The package features the standard symbols indicating rules to be followed when handling and storing the machine.
- Transport must be carried out according to the instructions on the package, handling with appropriate caution and avoiding impact of any type.
- Do not expose the machine to atmospheric agents (rain, sun, and cold).

Checks on receipt

- On receipt of the machine, carefully check all transport documentation is correct (against label on package).
- Check that the original packaging is not damaged.
- After removing the machine from its packing materials, make sure that the machine and any safety devices are intact.
- Packing materials (plastic bags, polystyrene foam, staples, etc.) must be kept out of the reach of children because they are potentially hazardous.

Advice for disposal of packaging



The packaging materials are eco-compatible and recyclable. For the protection of the environment they must not be dumped, but taken to a waste-disposal/recovery centre, according to local regulations.



Handling



Staff responsible for moving the machine must be aware of the risks in moving heavy loads.

Move the machine carefully, using, when possible, the correct lifting equipment (fork lift, for example).

If moving the machine by hand, make sure:

- enough people are available for the task, depending on the machine weight and how difficult it is to handle;
- to always use the necessary safety gear (shoes/gloves).

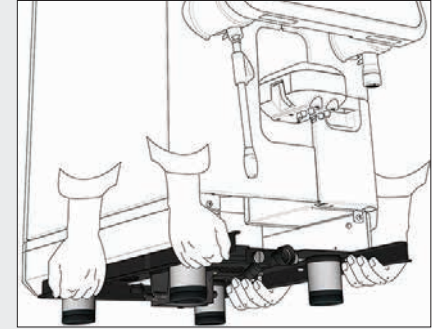

2.2 Installation Rules

- Before plugging in the machine, make sure that the information on the nameplate matches that of the electrical and water systems.
- Check that the power-supply cord is intact. Replace if damaged.
- Completely unwind the power-supply cable.
- The coffee machine should sit on a flat, stable surface at least 1 inch (20 mm) from walls and from the counter. Keep in mind that the highest surface on the machine (the cup warmer tray) sits at a height of at least 59 inches (1.5 meters). Make sure there is a shelf nearby for accessories.
- Room temperature must range between 50°F and 89.6°F (10° and 32°C).
- An electrical outlet, water connections, and a drain with siphon must be in the immediate vicinity.
- Do not install in rooms (kitchens) that are cleaned with jets of water.
- Do not obstruct openings or ventilation and heat vents.
- Do not install the machine outdoors.
- Do not install or use the machine in potentially explosive environments.
- Do not install the machine in the presence of flammable substances.



3. Electrical Installation Rules

Prior to installation, make sure there is a circuit breaker installed with a distance between the contacts that allows for complete disconnection when there is a category III overload and that provides protection against current leakage equal to 30 mA. The circuit breaker must be installed on the power supply in compliance with installation rules.

If the power supply is not working properly, the machine can cause transitory voltage drops.

The electrical safety of this machine is only ensured when it is correctly connected to an efficient earthing system in compliance with the electrical safety laws in force. This fundamental safety requirement must be verified. If in doubt, request that a qualified electrician inspect the system. The manufacturer cannot be held responsible for any damage caused by the lack of an earthing system on the electrical supply.

Do not use adaptors, multiple plugs, and/or extension cords.

Check that the type of connection and voltage correspond with the information on the nameplate: see *illustrations chapter figure 1*.

Radio and Telecommunication Terminal Equipment (R&TTE)

This equipment has been tested and found to comply with the limits for a Class B digital device, pursuant to Part 15 of the FCC Rules.

These limits are designed to provide reasonable protection against harmful interference in a residential installation.

This equipment generates, uses and can radiate radio frequency energy and, if not installed and used in accordance with the instructions, may cause harmful interference to radio communications. However, there is no guarantee that interference will not occur in a particular installation.

If this equipment does cause harmful interference to radio or television reception, which can be determined by turning the equipment off and on, the user is encouraged to try to correct the interference by one or more of the following measures:

- Reorient or relocate the receiving antenna.
- Increase the separation between the equipment and receiver.
- Connect the equipment into an outlet on a circuit different from that to which the receiver is connected.
- Consult the dealer or an experienced radio/television technician for help.



4. Water Installation Rules

WATER REQUIREMENTS

Water used in coffee machines must be potable and suitable for human consumption (see laws and regulations in force).

Check that the water inlet on the machine has pH and chloride values that comply with the laws in effect.

If the values do not fall within the limits, an appropriate water-treatment device must be inserted (respecting the local laws and compatible with the machine).

If the machine uses water with a hardness exceeding 8 °f (4.5 °d), a specific maintenance plan must be implemented according to the hardness detected and machine usage.

INSTRUCTIONS

Only use the supplied parts for installation. If other parts are installed, they must be new (unused tubes and gaskets for the water connection) and they must be permitted for contact with potable water suitable for human consumption (according to local laws in force).

WATER CONNECTIONS

Place the machine on a flat surface and stabilize it by adjusting and securing the feet.

Hook up the water connections as shown in the [Illustrations chapter, Figure 2](#), respecting the hygiene, water safety, and anti-pollution laws in the country of installation.

Note: If the water pressure can rise above 87 psi (6 bar), install a pressure reducer set at 29÷43 psi (2÷3 bar). See [Illustrations chapter Figure 3](#).

Water draining tube: place the end of the water draining tube in a drain with a siphon for inspection and cleaning.

IMPORTANT The curves of the water-draining tube must NOT bend as shown in [Illustrations chapter, Figure 4](#).

ATTENTION: This equipment is to be installed with adequate backflow protection to comply with the applicable federal, state or local plumbing codes having jurisdiction.

Connect the milk draining tube as shown in the figure at the side.

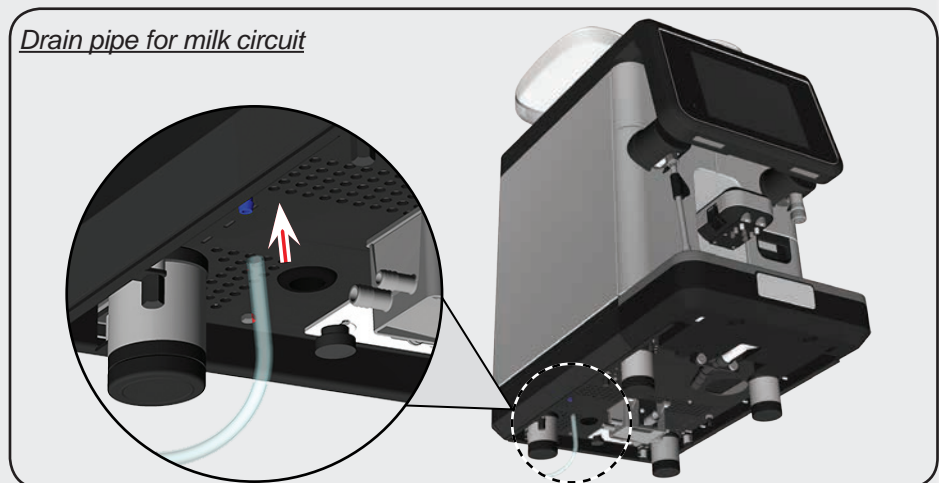



5. Installation Check-up

WARNING: AFTER INSTALLATION, CHECK IF THE MACHINE IS WORKING PROPERLY (see Installation Module C).

WATER CONNECTIONS

- No leaks from the connections or tubes

OPERATION

- Boiler and operating pressures are normal.
- The pressure gauge is working properly.
- The self-levelling device is working properly.
- The expansion valves are working properly

WARNING: ONCE THE MACHINE HAS BEEN INSTALLED AND IS READY FOR USE, BEFORE ALLOWING THE WORKER TO START USING THE MACHINE, WASH THE INTERNAL COMPONENTS ACCORDING TO THE INSTRUCTIONS BELOW:

COFFEE CIRCUIT

- Press the coffee circuit quick wash icon .

HOT WATER

- Continuously dispense hot water (using the appropriate button) until at least 0.5 litres of water have been used.

STEAM (where present)

- Dispense steam from the nozzles for about a minute, using the appropriate buttons.

MILK CIRCUIT (where present)

- Press the milk circuit wash icon  and proceed as indicated on the display.

SOLUBLES CIRCUIT (where present)

- Press the soluble circuit wash icon .

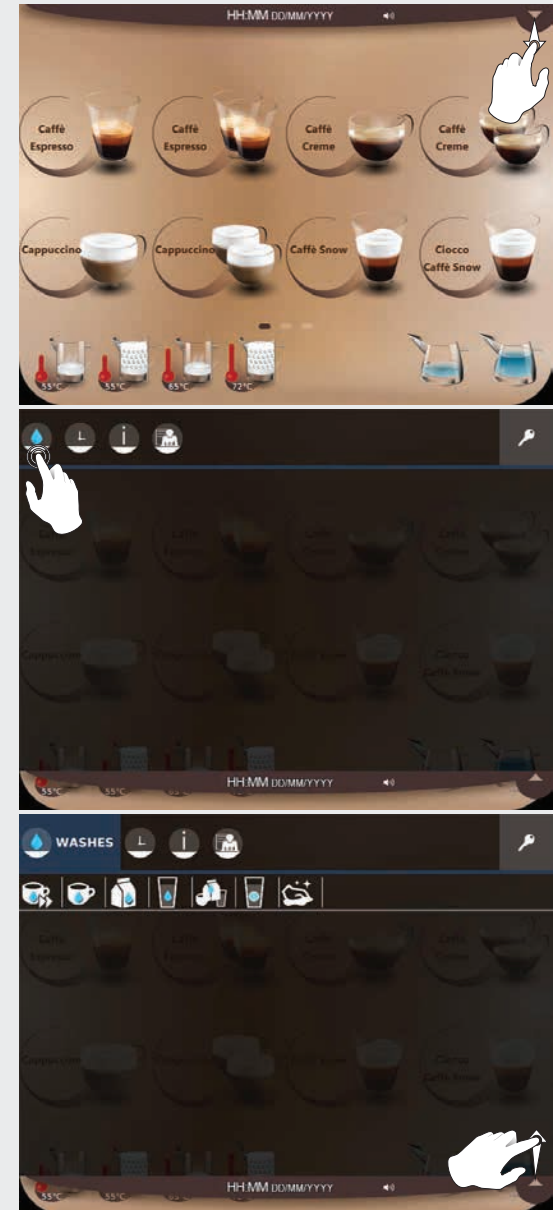



6. Operator instructions

BEFORE YOU START



WARNING: BEFORE YOU START OPERATING THE MACHINE, WASH THE INTERNAL COMPONENTS FOLLOWING THE INSTRUCTIONS INDICATED BELOW. THESE STEPS MUST BE REPEATED AT LEAST ONCE A DAY AND WHEN THE MACHINE HAS NOT BEEN OPERATED FOR MORE THAN 8 HOURS.

Coffee circuit: Press the coffee circuit quick wash icon .

Hot water: Continuously dispense hot water (using the appropriate button) until at least 0.5 litres of water have been used.

Steam (where present): Dispense steam from the nozzles for about a minute, using the appropriate buttons.

Milk circuit (where present): Press the milk circuit wash icon  and proceed as indicated on the display.

Solubles circuit (where present): press the soluble circuit wash icon .

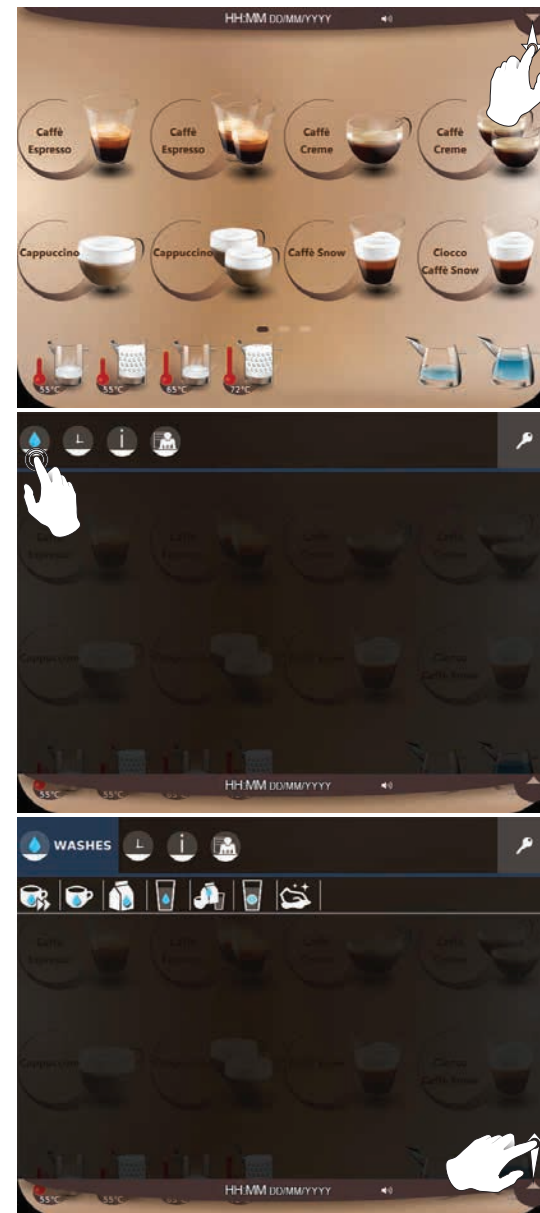



DURING OPERATION

Coffee / cappuccino / milk dispensing

- If the machine has not been used for more than an hour, before dispensing a beverage, perform a wash by pressing the coffee circuit quick wash icon .

Hot water dispensing

- If the machine has not been used for more than an hour, before making coffee, dispense water for 2 -3 seconds and discard the liquid.

Steam dispensing (where present)

- Before heating the beverage (water, milk, etc.), open the steam nozzle for at least 3 seconds and let the steam escape so that the condensation is eliminated.

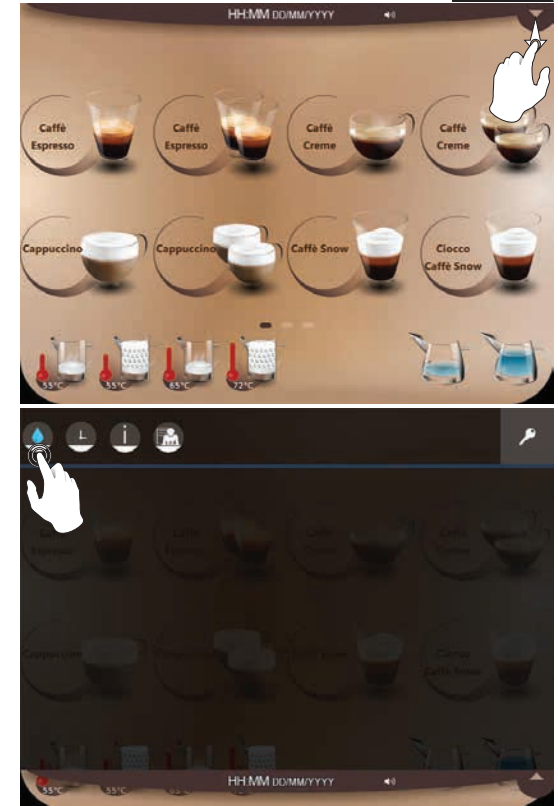



7. Warnings



Danger of burns

The areas marked with this sign become hot. **Great care should be taken when in the vicinity of these areas.**



WARNING: Hot surface
ACHTUNG: Heisse Oberfläche
ATTENTION: Surface chaude
ATTENZIONE: Superficie calda

GENERAL

The manufacturer disclaims all liability for damages to items or persons due to improper use or due to the coffee machine being used for purposes other than its intended use.

Do not operate the coffee machine with wet hands or bare feet.

Ensure that the machine is not handled by children or persons who have not been instructed in its correct use.

Danger of burns

Do not place the hands or other parts of the body close to the coffee distribution points, or near to the steam and hot-water nozzles.



MACHINE CLOSE-DOWN

When the machine is left unattended for a prolonged period (for example out of hours), carry out the following steps:

- Clean as indicated in the dedicated chapter;
- Remove the plug or turn off the main switch;
- Close the water tap.

NOTE: for machines which can be programmed to switch on and off automatically, the power must be left on only if this function is active.

Non-compliance with these safety measures exonerates the manufacturer from all liability for malfunctions, damage to property and/or injury to persons.



8. Maintenance and repair

If the machine is not working properly, turn off the machine, turn off the main off-on switch, and call the service centre.

If the power-supply cord is damaged, switch off the machine and request a replacement from the service centre.



To ensure safety during operation, it is absolutely necessary to:

- follow all the manufacturer's instructions;
- have qualified and authorized technicians periodically check that all safety devices are intact and functioning properly (the first inspection within three years of purchase and every year after that).



WARNING

Maintenance by unqualified individuals can jeopardize the safety and conformity of the machine.

Only use qualified, authorized technicians for repairs.

WARNING

Only use original replacement parts guaranteed by the manufacturer.

If original spare parts are not used, the manufacturer's warranty will no longer be valid.

WARNING

WARNING After maintenance, perform the installation CHECK-UP as indicated in the specific section of the user's manual.



9. Dismantling the machine

Electrical equipment cannot be disposed of as ordinary urban waste.

To protect the environment, please proceed in compliance with the local laws in force.



Suitable differentiated waste disposal so that the machine can then be recycled, treated and disposed of in an environmentally friendly manner contributes to avoiding possible negative effects on the environment and health, and encourages the reuse and/or recycling of the materials from which the machine is made.

Improper disposal of electric equipment that fails to respect the laws in force will be subject to administrative fines and penal sanctions.

ENVIRONMENTAL INFORMATION

This product contains a non-rechargeable lithium (lithium manganese dioxide chemistry) button cell battery fully encapsulated in the final product. Recycle or dispose of batteries in accordance with the battery manufacturer's instructions and local/national disposal and recycling regulations.

Location of the battery

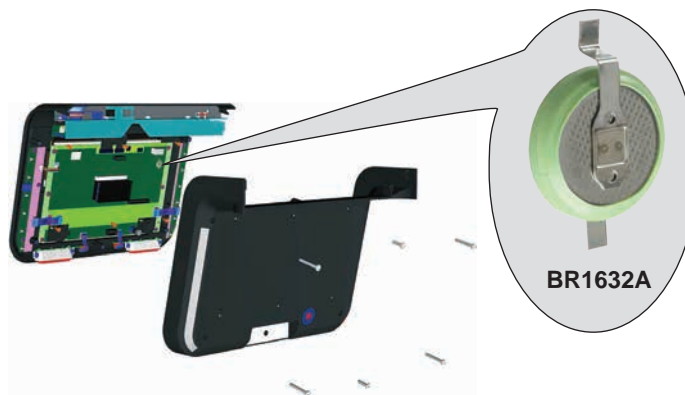



USE

10. Daily operation



Before setting the machine to work, make sure that:

- the main electric power switch is on;
- the mains water tap has been turned on.

MANUAL START UP

1

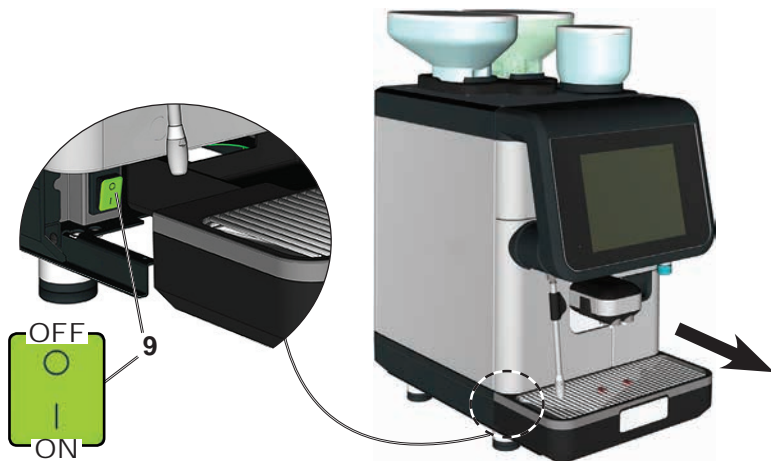

Press the ON/OFF switch (9) into **ON**  position.

2

The machine turns on and the display shows:



3

The machine is not ready to use until the icon  disappears from the display.

At this stage, the following will be displayed when you press any dispensing key  :

When a beverage cannot be dispensed, the relative icon becomes transparent, with a bar at the base  that shows heating status. These disappear when proper operating conditions for the beverage are reached.





FULL SHUT-DOWN PROCEDURE

1

Press the Sleep Mode button (8), located on the rear of the panel:

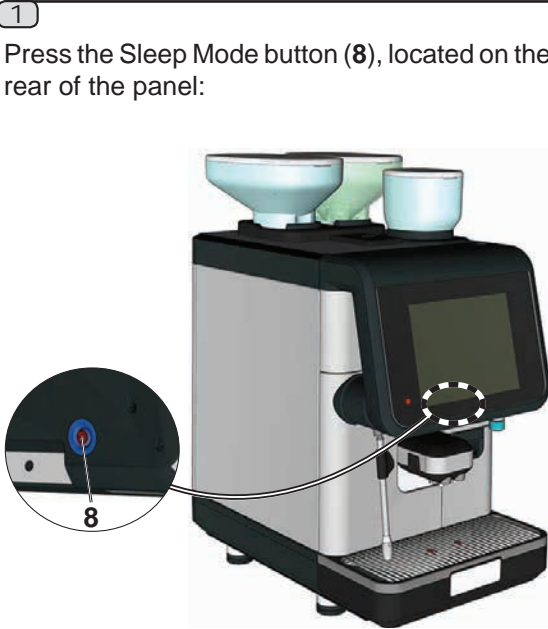

2

The following screen is displayed on the touch screen:

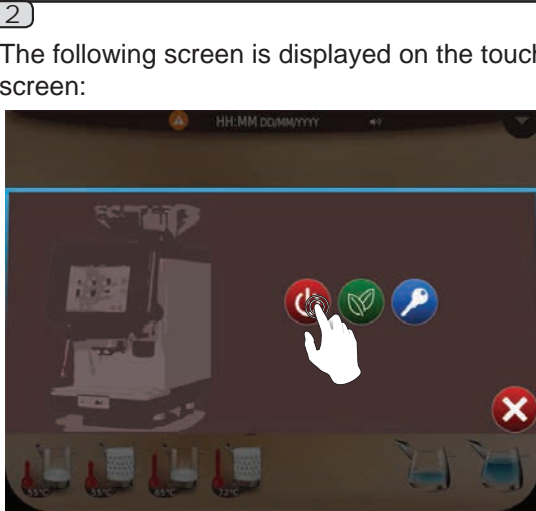

Push the  icon.

3

The screen shown below is displayed briefly:

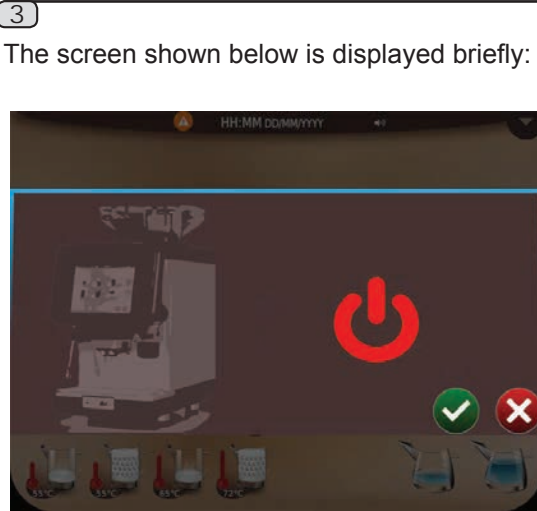

Then, the machine will switch off.

4

The red LED remains lit (7):



5

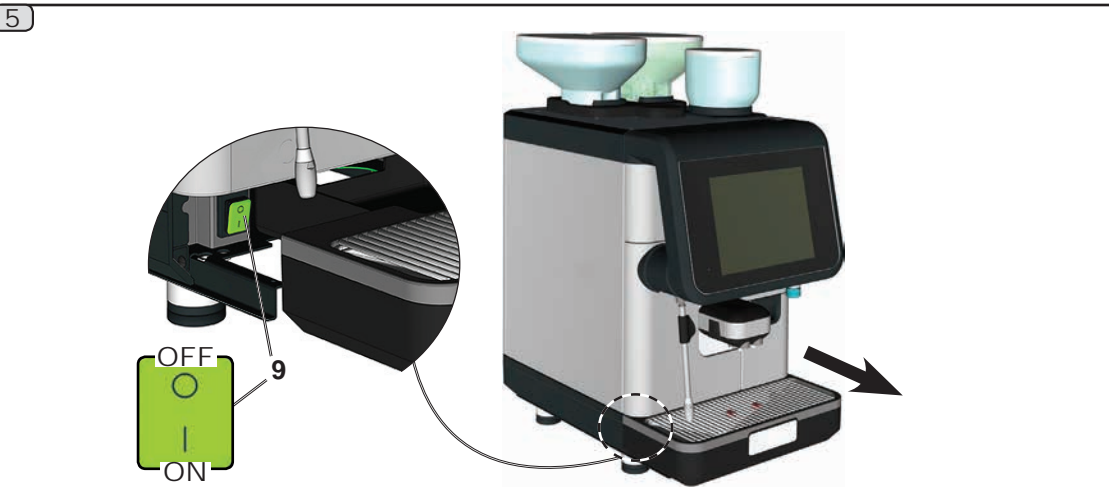

Fully shut down the machine pressing the main switch (9) into **OFF**  position.



11. Description of display symbols

English



Warning symbol: yellow notification, red malfunction

Machine cold symbol

Machine cold symbol associated with beverage icon

WiFi connection symbols (Green = connection to *Telemetry* portal operating; White = WiFi connection; Empty = no connection)

Volume symbols (excluded, minimum, medium, maximum)

Technical menu access symbol

Technical menu access symbol (advanced)

USB Pen Drive inserted symbol

Drop-down menu scrolling symbols

Grounds drawer full

No coffee (hopper 1 left, hopper 2 right)

No milk (container 1, container 2)

Decaffeinated coffee wafer

Machine switch-off (sleep mode)

Energy saving (sleep mode)

Access via password

Confirm operation

Cancel operation

Procedure for Dek beverages

Procedure for group wash with tablet

"not fresh coffee warning delay" icon

milk temperature above 41° F (5 °C) icon

Touch page

communication anomaly with payment system

Payment system symbols (Blue = system connected; Green = system connected and operational; Red = payment system has denied the transaction).



12. Beverage dispensing - Coffee - Cappuccino / milk - Chocolate/solubles

GENERAL INDICATIONS

Milk is a delicate biological product and can easily deteriorate. Heat modifies its structure. Milk must be kept at a storage temperature **no higher than 41°F (5°C)** from the moment the container is opened and throughout its entire period of use. Our storage appliances are suitable for this purpose.

NOTE: at the end of the work day (or not more than 24 hours from the time the container is opened), any remaining milk must be discarded.

CHOCOLATE AND SOLUBLES

These must be compatible with the machine: before use, read the instructions on the product packaging.

NOTE: the installation technician may be asked to customise what is displayed on the touch screen during beverage dispensing.

The available options are: beverage icon, image, film, physical attributes (temperatures, pressures).

During beverage dispensing, it is also possible to request that coffee dispensing time be displayed. E.g.: .

1







Place the cup under the dispensing nozzle (1) and adjust the height, if necessary; in versions with motorised spout, the height is adjusted automatically.

2

Up to 48 different beverage selections can be set in the machine, divided over several screens. To view the types of beverages that can be dispensed, scroll through the screens as shown:



Note: the icons  indicate the screen currently displayed (dark background ) and the total number of screens (light background )

The pre-set configuration means that after dispensing the beverages shown on pages with a light background , the touch screen will display the recipes shown on the main screen (dark background ). The "Back to Page One" setting can be disabled by the installation technician.



3 Press the icon corresponding to the selected beverage to start dispensing.





4 During dispensing, the screen will display as below:



Dispensing will stop automatically.

Press the icon  to stop dispensing the beverage before reaching the programmed dose.

Press the icon  to dispense again; the number indicating programmed dispensing will increase.

To reset, press and hold the icon  for a few seconds.

13. Beverage dispensing - Coffee / Cappuccino with powdered coffee

1 Place the cup under the dispensing nozzle (1) and adjust the height, if necessary; in versions with motorised spout, the height is adjusted automatically.



2 Open the decaffeinated coffee panel (5).

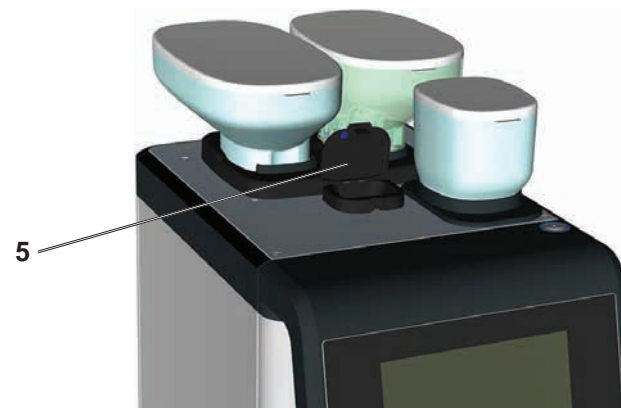



3 Push the  icon.



4 The touch screen will display the procedure for dispensing decaffeinated beverages:





5 Only icons for coffee powder-based beverages remain visible on the touch screen. Press the icon corresponding to the selected beverage to start dispensing.



6 During dispensing, the screen will display as below:

Dispensing will stop automatically.

Press the icon  to stop dispensing the beverage before reaching the programmed dose.



NOTE: coffee powder-based beverages do NOT allow repeat dispensing.



ALTERNATIVE PROCEDURE FOR DISPENSING POWDERED-COFFEE BEVERAGES (CAN BE SET BY TECHNICAL STAFF)

This setting is indicated by the presence of the special  icon on the touch screen.

1 After positioning the cup below the dispensing nozzle, press the **DECAF** icon :



2 The touch screen will display the procedure for dispensing decaffeinated beverages.

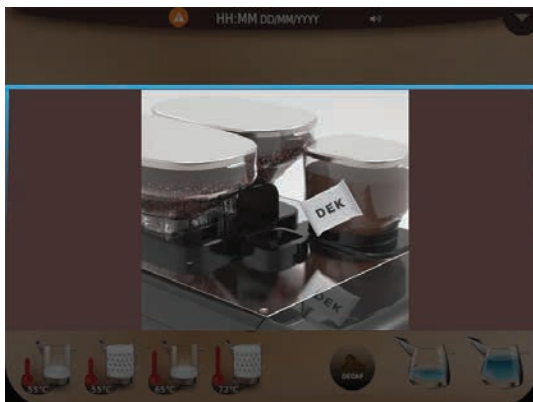

3 Open the decaffeinated coffee panel (5) and measure out a dose of powdered coffee into the tube and close the powdered coffee panel (5).



5 Only icons for coffee powder-based beverages remain visible on the touch screen. Press the icon corresponding to the selected beverage to start dispensing.



6 During dispensing, the screen will display as below:



Dispensing will stop automatically.

Press the icon  to stop dispensing the beverage before reaching the programmed dose.

NOTE: coffee powder-based beverages do NOT allow repeat dispensing.



14. Beverage dispensing - Hot water

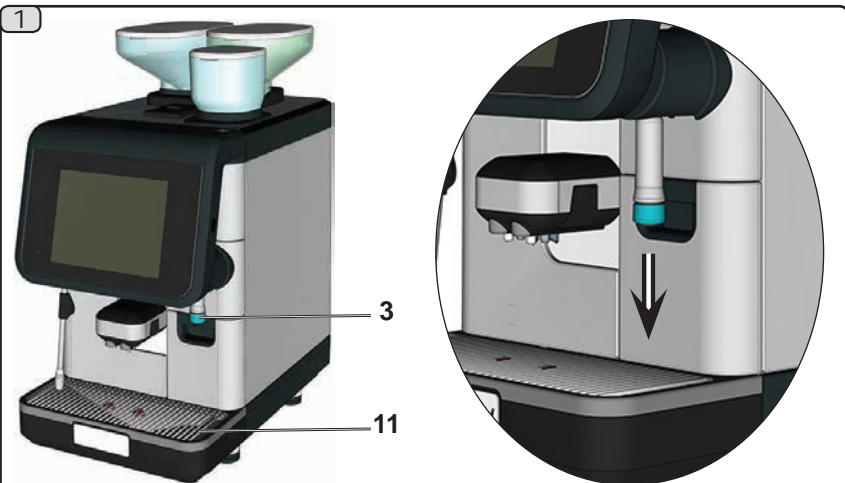



Place the appropriate container under the hot water dispenser (3). If necessary, adjust the height of the dispensing nozzle by pulling towards the basin (11).



Press a hot water dispensing icon .

The programmed dose of hot water will be dispensed from the nozzle (3); it will stop automatically.





Note: dispensing can be interrupted by pressing the  key.
Pressing the  key does not change the programmed parameters.

NOTE
The hot water icons can be personalised with a label for easier identification.

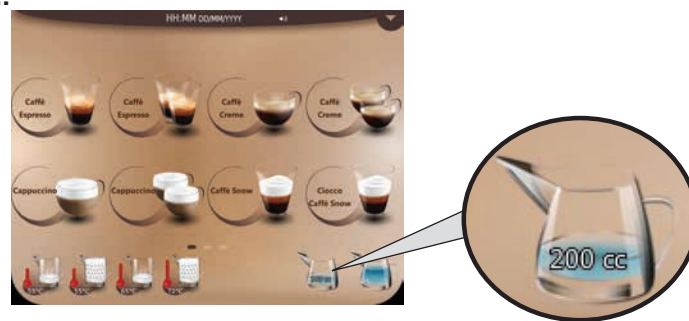
E.g.:



For activation methods, refer to the CUSTOMER PROGRAMMING/CUSTOMISATION/WATER/STEAM SETTINGS" section.

NOTE: the customisation  and programming  menus can only be seen if the "Customer Programming" item is enabled in the machine configuration menu, which can only be accessed by the installer technician.



15. Beverage dispensing - Steam

1



Completely immerse the steam dispensing wand (10) in the container with the beverage to be heated.



Scalding hazard! Use the appropriate insulating devices to move the steam nozzle.

2



Press a steam dispensing icon  .

3

The dispensing nozzle (10) will operate for the programmed time; it will stop automatically (*).



Note: dispensing can be interrupted by pressing the  key.

Pressing the  key does not change the programmed parameters.

(*) In the case of manual steam, the user must stop dispensing.



Cleaning the steam wand

After each use:

- wash the outside with hot water and a clean sponge, removing any organic residue; rinse thoroughly.
- clean the inside of the wand as follows: turn the nozzle towards the cup tray and carefully activate steam dispensing at least once.



16. Cleaning and maintenance



For correct application of the **food safety system (HACCP)**, please follow the instructions in this paragraph.

Washing must be done using the original "Service Line" products. See details on the last page. Any other product could compromise the suitability of the materials which come into contact with food products.

GENERAL OVERVIEW OF CLEANING INTERVALS

	EVERY USE	DAILY	WEEKLY	WHEN NECESSARY OR REQUESTED VIA SW	TOOLS TO USE
COFFEE CIRCUIT		√		√	• detergent tablet (3)
STEAM PIPE	√	√			• sponge (5)
AUTOMATIC STEAM PIPE	√	√			• sponge (5)
WATER PIPE		√			• sponge (5)
BODYWORK		√		√	• soft cloth (6)
MILK CIRCUIT		√		√	• washing tray (1) • liquid detergent (2)
TOUCH SCREEN		√			• microfibre cloth (4)
CUP TRAY		√			• sponge (5)
HOPPERS		√			• specific (7) or similar product for objects in contact with food. • damp cloth
DECAF DOOR		√			• damp sponge (5)
SOLUBLE MIXER			√	√	• liquid detergent (2) • sponge (5)

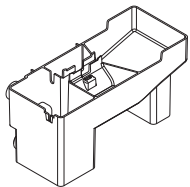

(1)



(2)

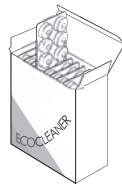

(3)

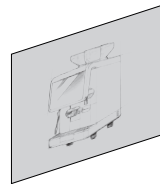

(4)

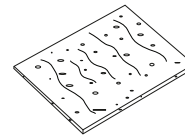

(5)



(6)



(7)

For cleaning operation details, see the dedicated sections on the following pages.



Procedure to follow at the end of the working day or when signalled by the machine.

NOTE: the following operations must be carried out when the machine is on and heated.

There are several types of machine washing:



COMPLETE WASH

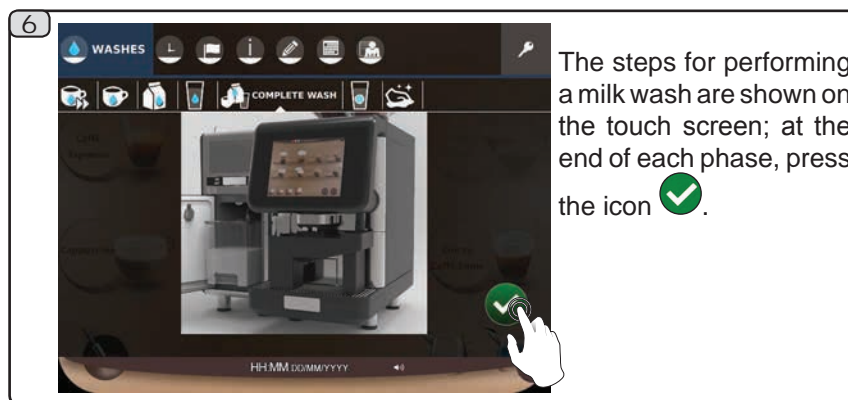
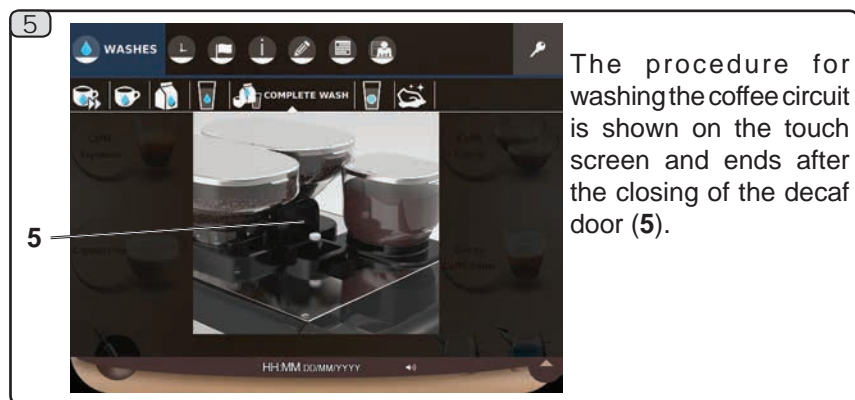
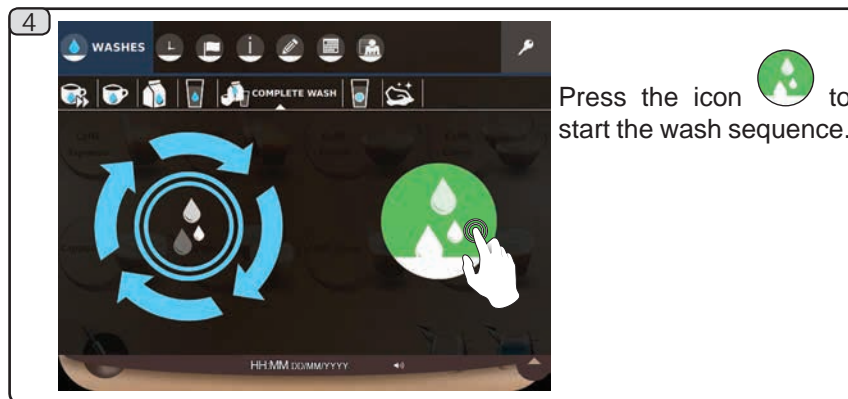
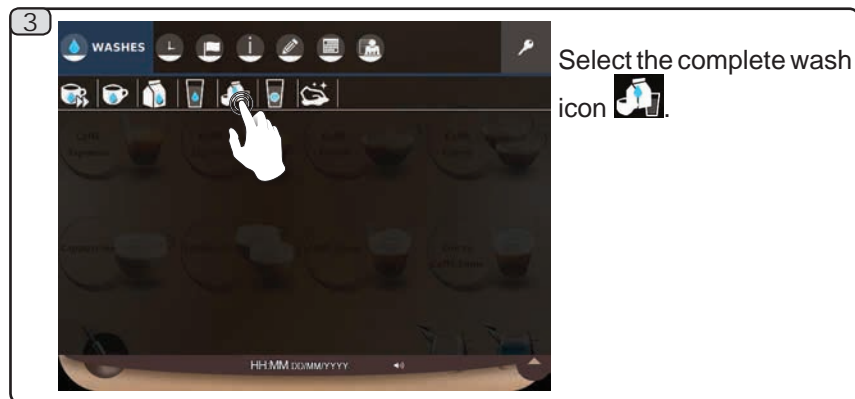
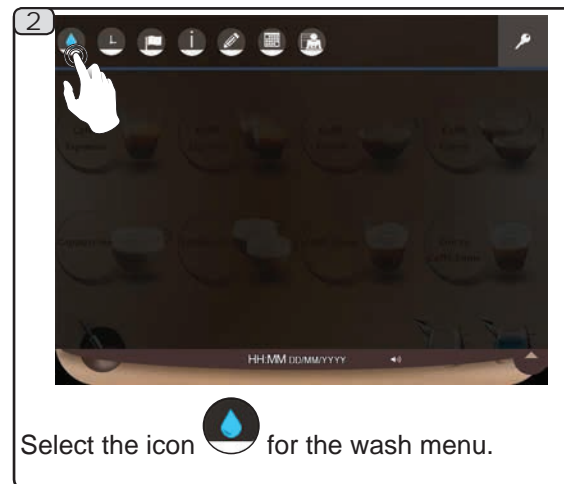
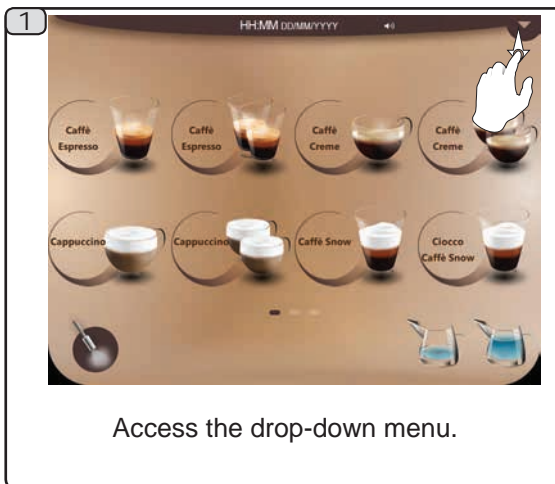

(duration, approx. 15') which cleans all the circuits is illustrated below.

For the individual types of washing, refer to the "CUSTOMER PROGRAMMING/WASH" section.



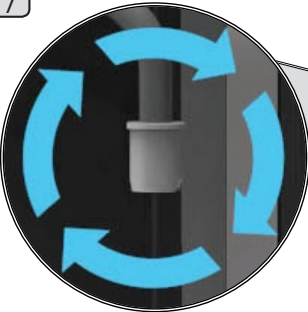

7

Clean the milk tube thoroughly.

Use a detergent solution (approximately ½ litre of cold water for every dose of detergent - see product instructions) to thoroughly clean the previously removed milk container.



8



Insert the milk tube connector into the washing tray. Carry out the operations as shown on the touch screen.

9



Washing starts and the progress bars below will show when it is completed.



IN PLACE CLEANING: CLEANING THE MILK CIRCUIT (WHERE PRESENT)

MILK WASH (DURATION, APPROX. 12')

1

Select the  icon for the milk circuit wash.

2

Press the icon .

3

The steps for performing a milk wash are shown on the touch screen; at the end of each phase, press the icon .

4

Clean the milk tube thoroughly.
Use a detergent solution (approximately ½ litre of cold water for every dose of detergent - see product instructions) to thoroughly clean the previously removed milk container.

5

Insert the milk tube connector into the washing tray.
Carry out the operations as shown on the touch screen.

6

On the touch screen the milk circuit wash symbol appears, and remains visible for the entire cycle. This stage ends when the progress bar below is filled.



IN PLACE CLEANING: part 1 of 2: CLEANING THE MIXER (WHERE PRESENT) (extract from videos)

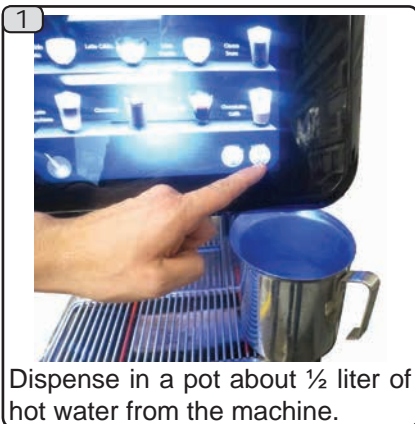

Dispense in a pot about ½ liter of hot water from the machine.

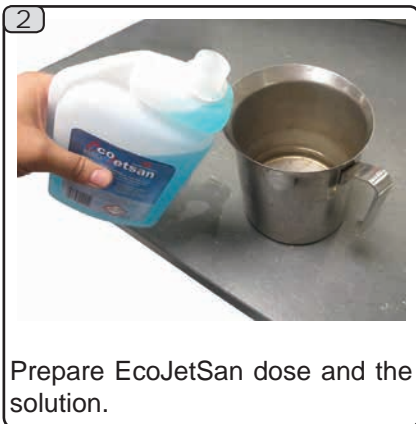

Prepare EcoJetSan dose and the solution.



Prepare the solution.



Push on top to open the front panel.

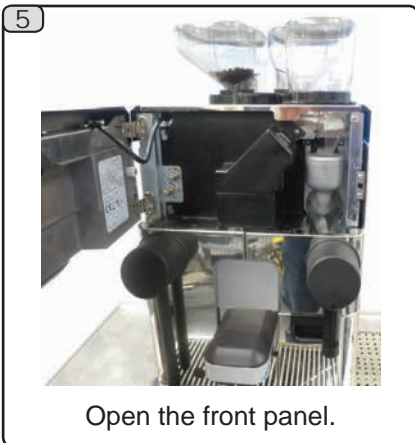

Open the front panel.

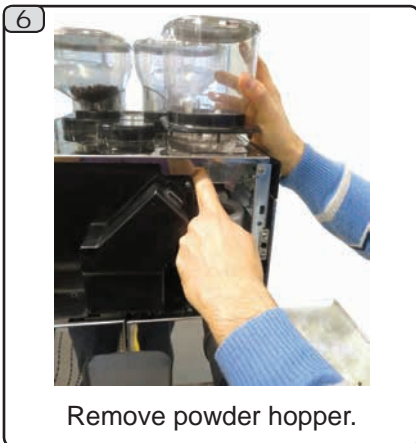

Remove powder hopper.



Remove top mixer part

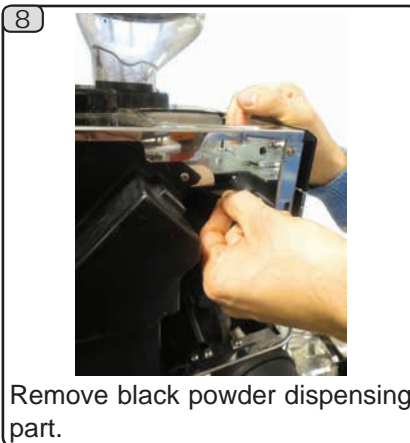

Remove black powder dispensing part.



Disconnect elbow.

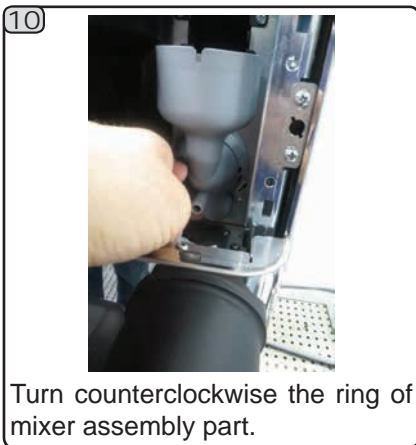

Turn counterclockwise the ring of mixer assembly part.

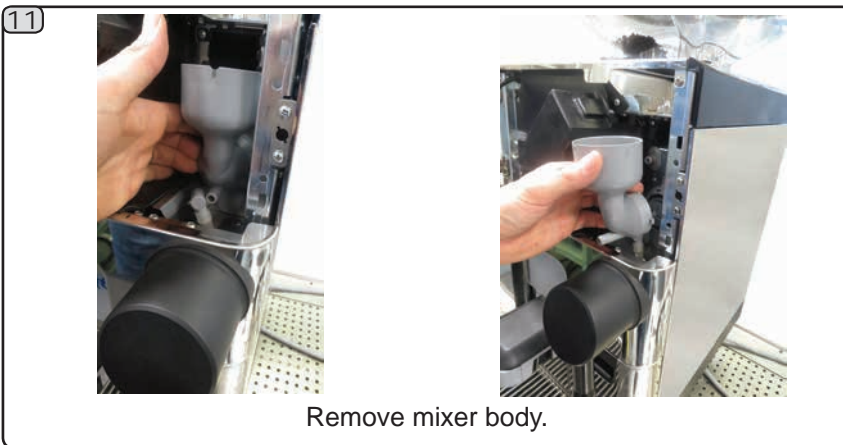

Remove mixer body.



Remove wheel.



Remove elbow from the silicone pipe.

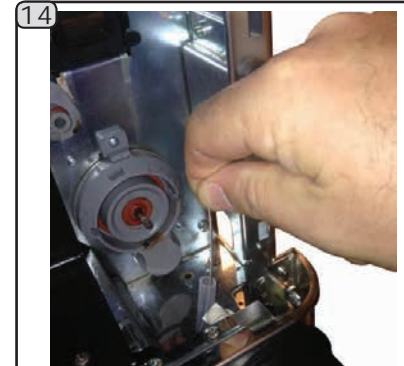
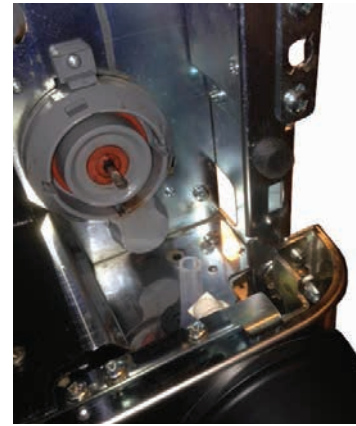

Using the brush clean the silicone pipe



Remove the cover from the dispensing nozzle.



Push on both sides and move the coffee spout as shown above.



Push on both sides and move the milk spout as shown above.

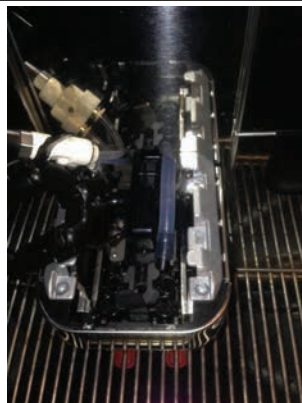

Push the metal lock to the front and remove it.

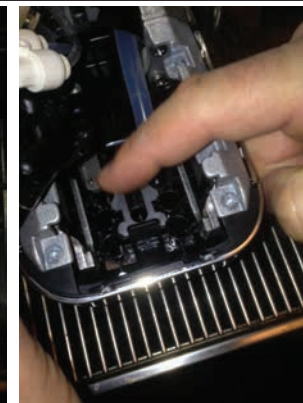



19



Move the soluble spout as shown above.

20



Remove elbow from silicone pipe, then clean pipe with the brush.



21

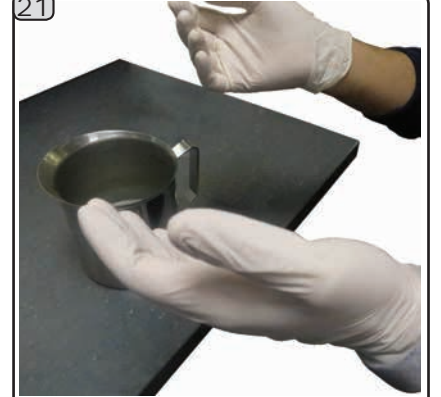

Put gloves on your hands.

22



Put a sponge in the solution and then clean the mixer fixed part.



23



Put all the removed mixed parts (except the soluble hopper) in the solution, then clean them accurately with a sponge.



24

CLEANING SOLUBLE SHOPPER

Remove any soluble powder remaining in the hopper. Wash with a damp cloth and the products and methods normally used for articles in contact with food; rinse thoroughly and dry, removing any organic residue.

Before replacing the hopper on the machine, make sure that wet or moist parts are completely dry.

25



Rinse all parts (fixed part too) with cold water accurately.



26



Dry the parts.



27



Put correctly the polarized wheel (the arrow must be directed to the plane part of the stainless steel motor shaft).

28



Re-assembly the other mixer parts according to disassembly rules.

29



Close the front panel (touch screen).

IN PLACE CLEANING:
part 2 of 2: **CLEANING THE SOLUBLES CIRCUIT**

 **SOLUBLES WASH (DURATION, APPROX. 30")**

1



Select the  icon for the solubles circuit wash.

2



Press the icon  to start the wash cycle.

3



On the touch screen the solubles wash symbol appears, and remains visible for the entire cycle. This stage ends when the progress bar below is filled.



TOUCH SCREEN



To avoid accidental activation of the touch screen during cleaning:

Warning: to clean the touch panel, use only a dry anti-static microfibre cloth.

Do not use: • detergents or liquids in general; • paper or rough cloths.



Select the  icon related to cleaning the touch screen.



Press the  icon displayed at the centre of the screen.

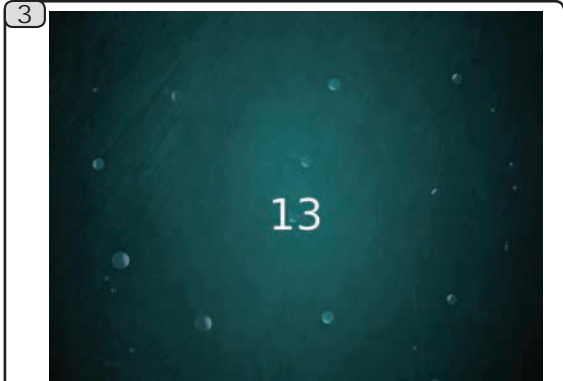

A 15-second countdown will begin in which to clean the touch screen.

GROUNDS DRAWER (2)

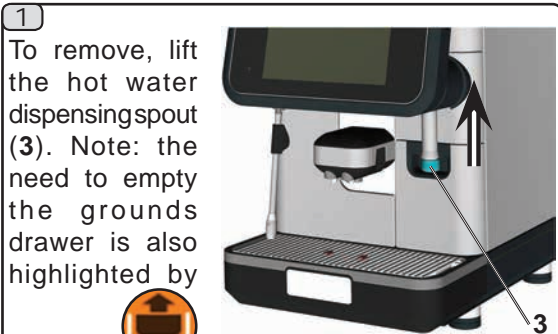

To remove, lift the hot water dispensing spout (3). Note: the need to empty the grounds drawer is also highlighted by

the icon  on the touch screen.

After the icon appears, 10 more coffee-based beverages can be dispensed, after which an animation will be seen on the touch screen to empty the drawer. Any additional dispensing is blocked and the grounds drawer must be emptied.

Pull out the grounds drawer (2), empty it and wash it under running water. Thoroughly clean the drawer housing area (2) with a damp cloth, removing any organic residue.

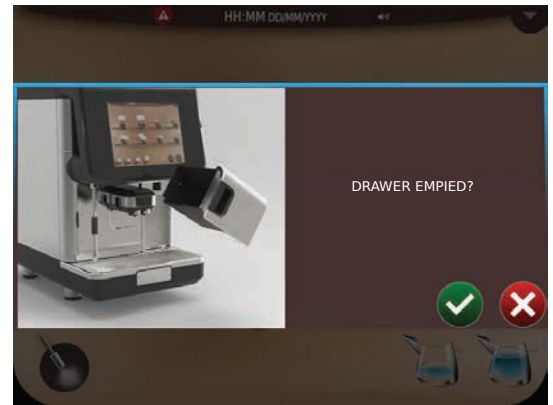

NOTE: the operator must confirm drawer emptying before re-inserting the drawer.

If confirmed using the icon , the grounds count is reset.



NOTE: the procedures described below must be carried out when the machine is switched off.

CUP TRAY (11)

1

At the end of the working day, pour a jug of hot water into the basin (11) to remove any encrustation in the drain; remove it and wash it with running water.



2

To remove it, grip and pull the basin (11) lifting it slightly. Do not use abrasive products; do not put in the dishwasher.



DECAFFEINATED DOOR (5)

Use a damp sponge to remove any residue on the inside of the door and in the decaf coffee conduit.

5

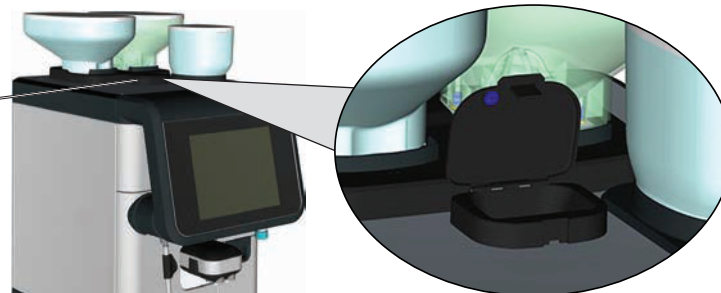

BODYWORK

Warning: the shiny parts of the bodywork must be cleaned using a soft cloth and cleaning products WITHOUT ammonia or abrasives, removing any organic residue present in the work area. In the case of tough dirt, use a damp sponge and dry with a soft cloth.

Note: DO NOT spray liquid in the slots of the body panels and DO NOT use paper or rough cloth for cleaning.





Maintenance to be performed every 7 days

CLEANING THE COFFEE HOPPER (6A - 6B)

The coffee hoppers (6a and 6b) must be cleaned regularly, roughly once a week. Depending on consumption and the type of coffee, more frequent cleaning may be required. To clean, proceed as follows:

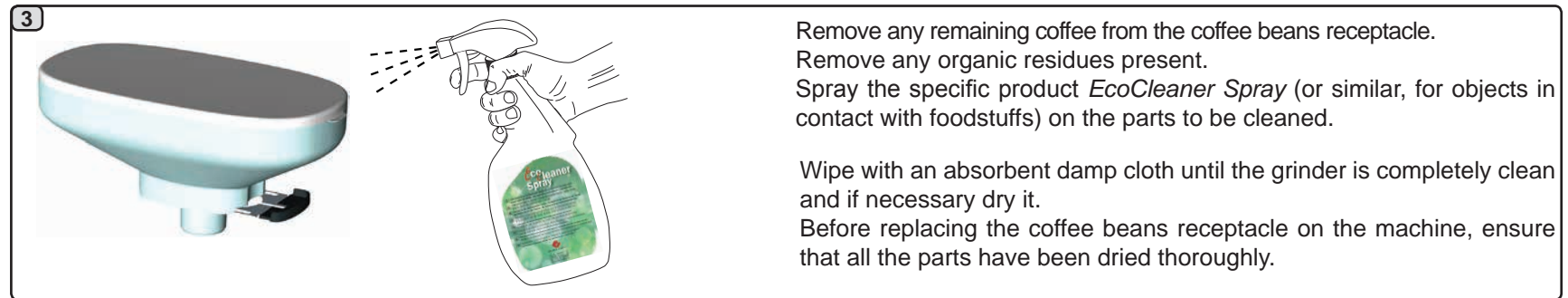
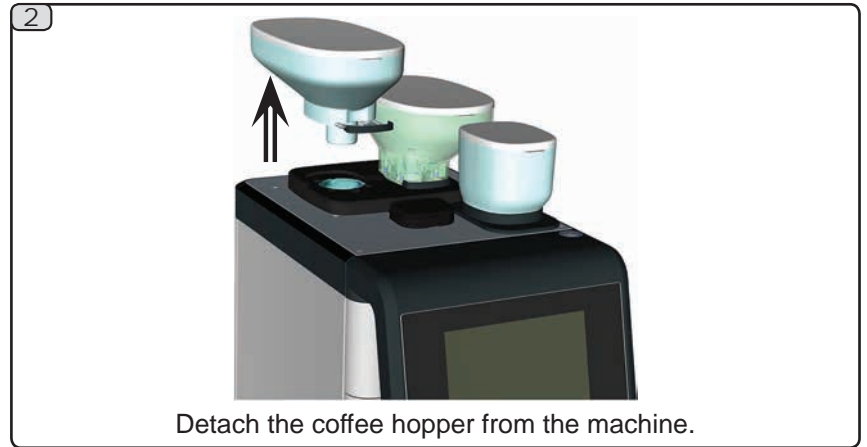
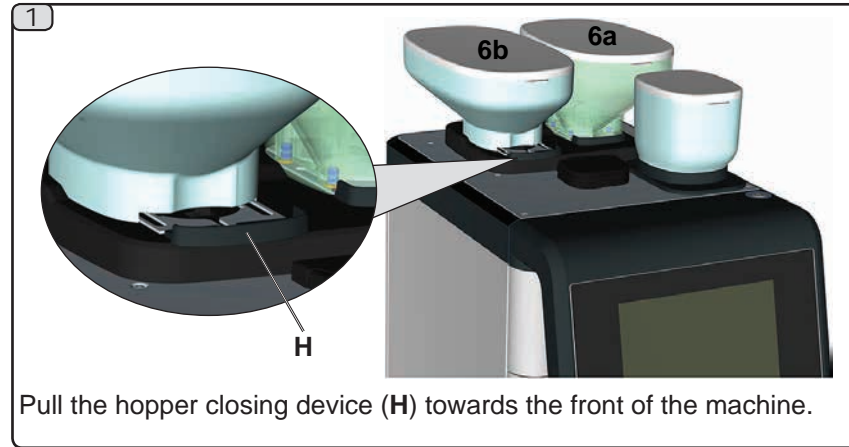



17. Diagnostics messages

There are 2 types of messages that are displayed by the machine:





- 1. Explicit messages:** they appear on the screen accompanied by an explanatory clip or are shown in the form of an icon in the upper right-hand corner of the display.
- 2. Coded messages:** they are placed in the upper left-hand corner and are represented by the unit's numerical error code.

If there are several errors, they are represented one after another on the display.











For a detailed description of messages in code, refer to the technical manual, "Defects - Malfunctions" section.



Explicit messages

MESSAGE	CAUSE: when displayed	SOLUTION
Machine cold	<p>1. This message is displayed when the dispensing key is pressed the machine is not at an adequate temperature for operation</p>  <p>The  icon represents machine cold status. Once the appropriate pressure and temperature are reached, it automatically disappears.</p> <p>2. When the service boiler or boiler respectively cannot reach the operating pressure or temperature due to a problem, an error code appears on the display which identifies the defective component causing the problem.</p>	<p>2. Consult the Technical Manual to find the specific error code to resolve the problem.</p>
Grounds drawer full	 <p>The  icon informs the user that the grounds drawer is full. Ten coffee based beverages can still be dispensed (10 single or 5 double) before the machine stops.</p>	<p>Empty the drawer to clear the message or continue until the machine displays the message "Empty grounds drawer".</p> <p>Refer to the Technical Manual to program the grounds limit after which the message is displayed.</p>
Empty grounds drawer	<p>The machine counts down from the limit set for grounds. The message (along with a film) is shown on the display when it reaches zero. The machine is blocked and does not allow any dispensing.</p>	<p>Remove and empty the grounds drawer. Return the drawer to its proper position. While carrying out this operation, the message "grounds drawer removed" will be displayed.</p>
Grounds drawer removed	<p>This message (along with a film) is always shown when the rear side of the drawer is not in place.</p>	<p>If the message appears with the drawer inserted, check that the drawer is properly placed.</p>



<p>Provide for Maintenance</p>	<p>This message is displayed when the machine requires maintenance. To temporarily eliminate the message, press the  icon. The message will appear again the next time the machine is turned on.</p>	<p>Contact an authorised technician. The message will be displayed every day and every time the machine is switched on until the maintenance is performed. Consult the Technical Manual to program maintenance times and cycles.</p>
<p>Regenerate resins</p>	<p>This message is displayed when the resins in the water softener require regeneration. (See water softener maintenance instructions).</p>	<p>The icons  and  remain active:</p> <ul style="list-style-type: none"> - press  to clear the message and the next regeneration request will appear one minute after the limit for litres dispensed is reached; - press  and the appearance of the request is postponed for one hour. <p>A similar situation occurs with the water filter replacement message: press the confirmation key  and the counter adds 25 litres to the limit set by the technician. NOTE. A technical operation to replace the water filter will be required to clear the message definitively.</p>
<p>Machine off</p>	<p>When the machine is in sleep mode, the red LED on the left side of the display remains on.</p>	<p>Press the button on the back of the display to reactivate the machine.</p>
<p>Messages regarding washing</p>	<p>Graphic messages requesting the various washes appear on the display.</p>	<p>See the "Cleaning and maintenance" section in this manual.</p>
<p>No coffee</p>	<p>The icons   indicate that one or more of the hoppers are almost empty.</p>	<p>Add coffee to the hopper(s).</p>
<p>No milk</p>	<p>The icons   are shown only if the machine is equipped with a refrigeration unit and with presence sensors of milk: indicates that one or both of the milk containers are empty.</p>	<p>Fill one or both of the milk containers.</p>



18. Defects - Malfunctions

Direct action by the customer

Before calling service personnel, to avoid unnecessary expense, check whether the machine problem corresponds to one of the cases listed below.

PROBLEM	CAUSE	SOLUTION
The coffee machine does not work and the touch screen (4) is off.	No electricity supply.	Check the electricity supply. Check the position of the ON/OFF switch (9).
Water leaking from the cup tray (11).	Drain clogged.	Clean.
Coffee dispensing time too short.	Low coffee dose. Coffee too old. * Coffee ground too coarse.	Increase the dose. Use new coffee. * Use a finer grind.
Coffee drips out of machine.	High coffee dose. * Coffee ground too fine. Filter blocked.	Decrease the dose. * Use a coarser grind. Clean with a wash cycle.
Loss of water under the machine.	Discharge clogged up. Discharge basin hole blocked.	Clean.
Machine heated up, but it does not dispense coffee.	Water supply or water softener tap closed. No water in system.	Open. Wait until water is available or call the service centre.
The automatic level-control devices remain in operation.	Same causes as above.	Same solution as above.

* These operations are possible **ONLY** if the "User Programming" item is enabled in the machine configuration menu, which can only be accessed by the installer technician.



CUSTOMER PROGRAMMING

DATE AND TIME



1 Programming is accessed through the drop-down menu.



2 Select the icon to see the associated menu.

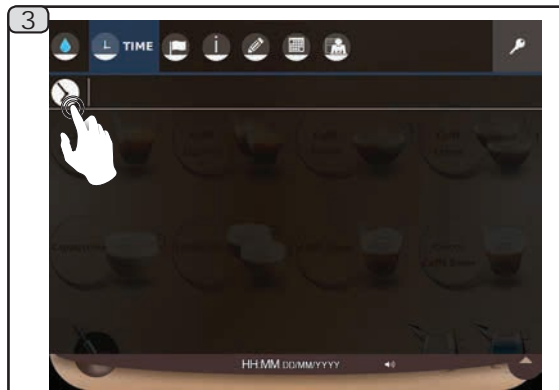

3 Select the icon for the "DATE AND TIME" menu.



4 Set the date and time and confirm with the icon .

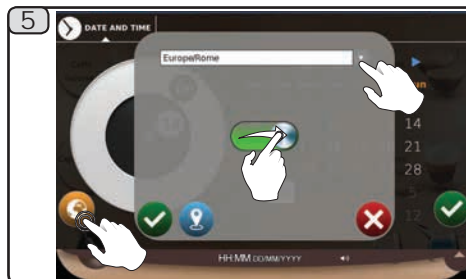

NOTE: date and time can be automatically synchronized through connection to a Network Time Protocol (NTP) server, if the machine is connected to the internet via WiFi.

LANGUAGE



1 Select the icon, relative to the "LANGUAGE" menu.



2 Set the menu language; confirmation is immediate.

NOTE. If the machine is connected to the Internet, press the icon to find the machine's location and then automatically set the correct time zone on the basis of the geographic location.



Illustrations

- see *Installation Rules* chapters

Fig. 1



Single-phase connection

① N White T Black ② N Blue T Brown

Fig. 2

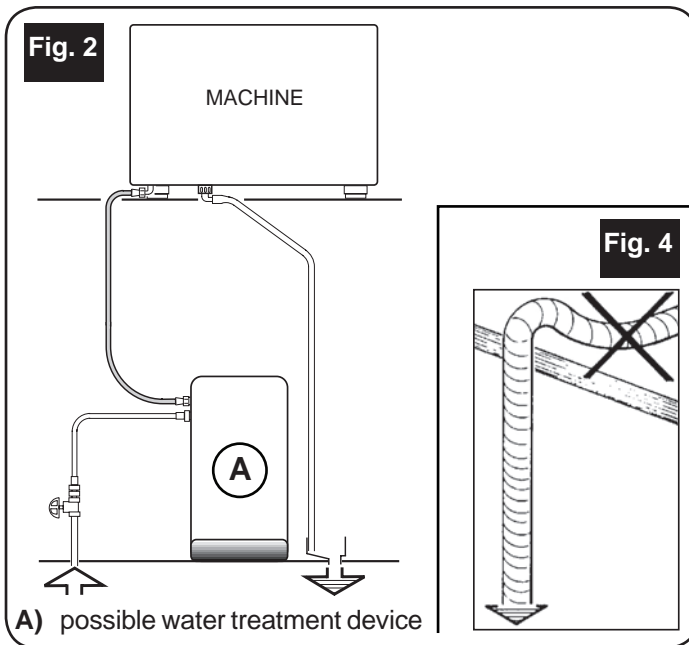
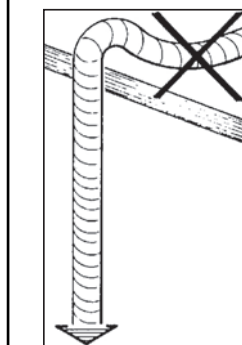

Fig. 4



Ø 3/8 GAS

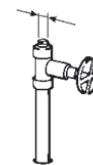
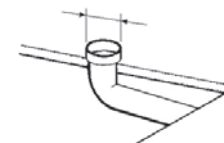

Fig. 3

Install a water feeding tap
WATER MAINS MAX. PRESSURE
87 psi - 6 bar - 0,6 MPa
 (for pressure beyond this value, install a pressure reducer)

DRAIN

Min.
 Ø 2 inches (50 mm).



GRUPPO CIBALI S.p.A.
 Via A. Manzoni, 17
 20082 Binasco
 (MI) Italy

GRUPPO CIBALI reserves the right to make changes to the machines in accordance with the needs of individual countries and on the basis of technological progresses.
 This publication may not, either in whole or in part, be used, copied or published without the written authorisation of GRUPPO CIBALI S.p.A.
 © Copyright by GRUPPO CIBALI S.p.A., Milan, Italy
 All rights reserved

SERVICE LINE

GRUPPO CIBALI and the "SERVICE LINE"

The GRUPPO CIBALI Company's client service, the aim of which is to assure top coffee-machine performance for its clients at all times, also makes available its ECO LINE, a series of specific cleaning products expressly designed for this purpose.

ECO LINE - Cleaning products

- A) 610-004-159 For cappuccino makers in liquid form
- B) 610-004-280 For dispensers, filter-holders, coffee cups in powder form
- C) 610-004-254 For dispensers, filter-holders, coffee cups in powder form
- D) 610-004-217 For superautomatic-machine dispensers in tablet form
- E) 610-004-251 For hopper, display - professional cleaning Eco Cleaner Spray.

Order directly from your local distributor and refer to the particular item you require by its number, as shown above.

IT SERVICE LINE

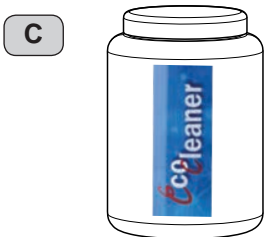

The Manufacturer reserves the right to modify the appliances presented in this publication without notice

GRUPPO CIMBALI SpA - 20082 BINASCO (MILANO) ITALY



CERT. NR. 50 100 3685 / 10877 / 11721