

S15

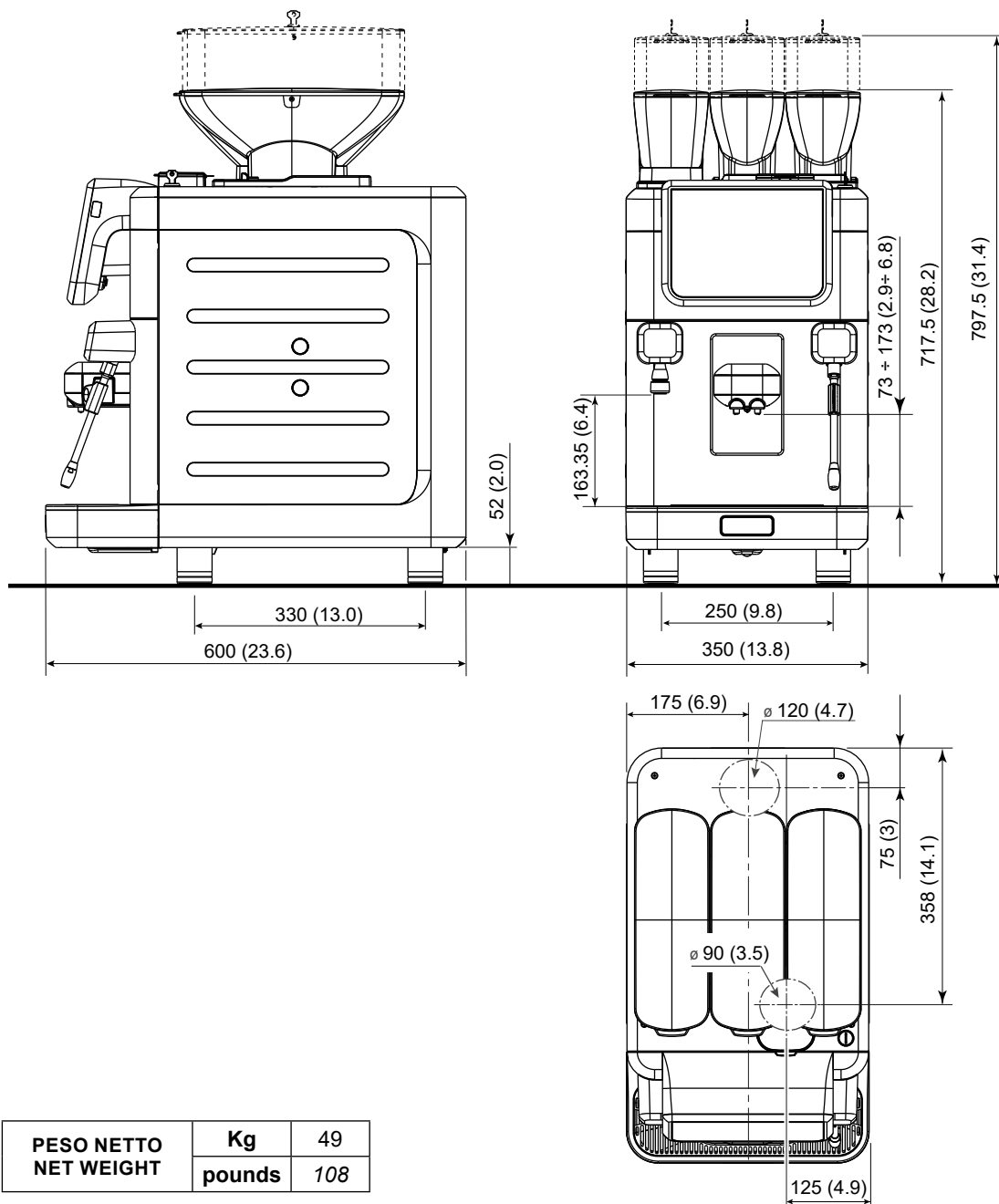

PESO NETTO NET WEIGHT	Kg	49
	pounds	108

MACCHINA MACHINE	ALIMENTAZIONE ELETTRICA POWER SUPPLY	POTENZA INSTALLATA INSTALLED POWER	CORRENTE DI LINEA LINE POWER	SEZIONE CAVO ALIMENTAZIONE SUPPLY CABLE SECTION
S15	220 - 240 V 50 Hz 220 V 60 Hz	2.7 - 3.1 kW 2.7 kW	13 A	3 x 1,5 mm ²
	220 - 240 V 50 Hz 220 V 60 Hz	2.0 - 2.3 kW 2.0 kW	10 A	3 x 1,5 mm ²
	208 - 240 V 60 Hz	2.4 - 3.1 kW	13 A (20 A plug)	3 x 14 AWG
	220 V 60 Hz	2.7 kW	13 A	3 x 1,5 mm ²
	100 V 50-60 Hz 200 V 50-60 Hz	1.1 kW 2.2 kW	11 A	3 x 1,5 mm ²

INTERRUTTORE	- Omnipolare con distanza di apertura contatti 3 mm - Protezione da corrente di dispersione con valore pari a 30 mA	SWITCH	- Omnipolar, 3 mm opening contact distance - Protection from leakage current with a value equal to 30 mA
MESSA A TERRA	- Obbligatoria	GROUNDING	- Required
ALLACCIAMENTO IDRAULICO	- \varnothing 3/8 gas	HYDRAULIC CONNECTION	- \varnothing 3/8 gas
PRESSIONE DI ALIMENTAZIONE IDRAULICA	- 2 ÷ 6 bar (0.6 MPa) con portata minima 2 L/min	HYDRAULIC FEEDING PRESSURE	- 2 ÷ 6 bar (0.6 MPa) with minimum flow rate 2 L/min
SCARICO IDRAULICO	- \varnothing min. 50 mm	WATER DISCHARGE	- \varnothing min. 50 mm