

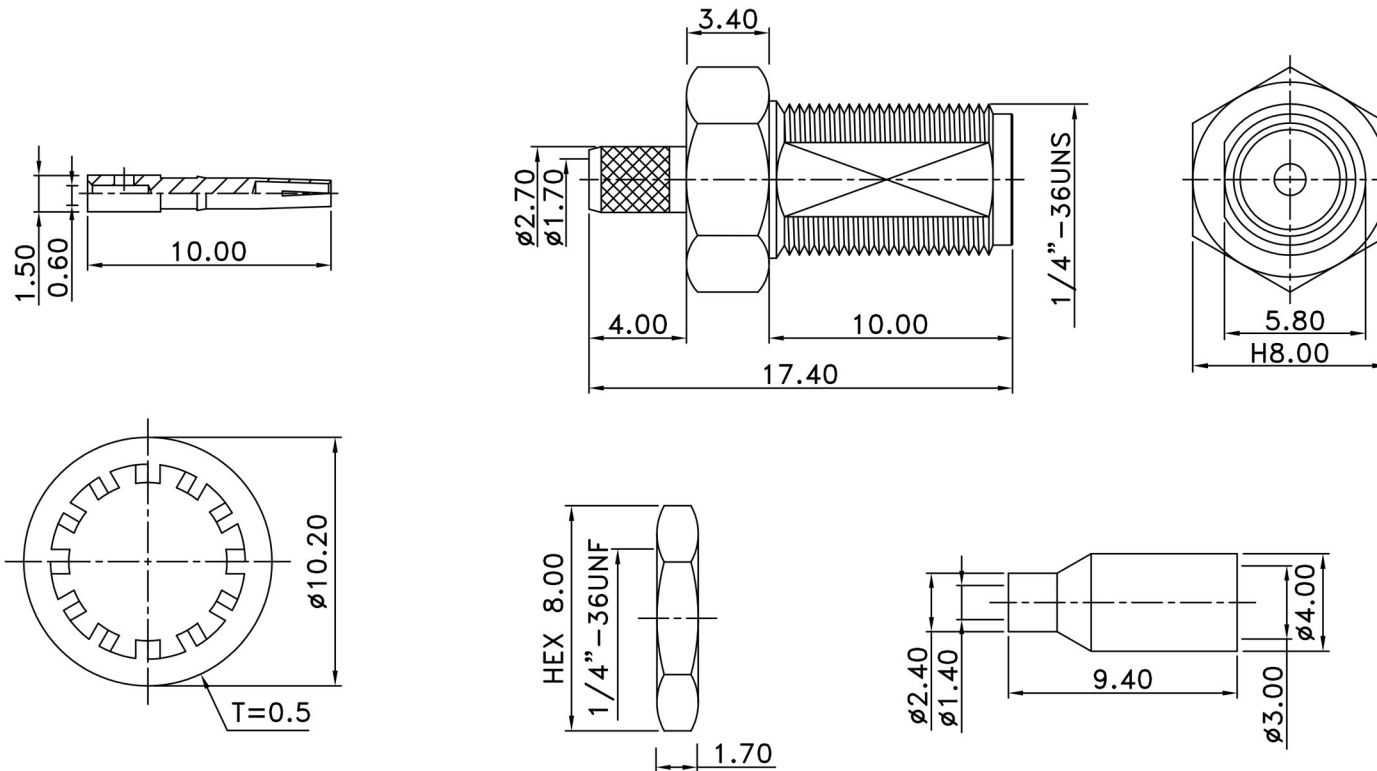

58 Wakis Avenue, Strijdompark, Randburg 2155, Johannesburg  
 Tel: +27 11 791 1033 | Fax: +27 11 791 1187 | wireless@otto.co.za | www.otto.co.za

## SMA-02-71-I-TGG SMA bulkhead crimp jack for 1.13mm micro cable

REV	DESCRIPTION	DRAWN	DATE



6	NUT	1	BRASS	GOLD
5	WASHER	1	BRASS	GOLD
4	FERRULE	1	BRASS	GOLD
3	DIELECTRIC	1	TEFLON	NONE
2	PIN	1	PHOS BRONZE	GOLD
1	BODY	1	BRASS	GOLD
NO	Description	Q'ty	Material	Finish

UNLESS OTHERWISE SPECIFIED  
 1. REMOVE ALL BURRS.  
 2. BREAK ALL CORNERS & EDGES CO.15T MAX.  
 3. CHAMFER 1ST & LAST THREADS 45°  
 4. DIAMETERS ON COMMON CENTERS.  
 TO BE CONCENTRIC WITHIN 0.1 TIR  
 5. ALL DIMENSIONS ARE AFTER PLATING.

\* MAJOR DIMENSION  
 UNLESS OTHERWISE NOTED TOLERANCES  
 0.5-6=±0.2  
 6-30=±0.4  
 30-120=±0.6  
 120-315=±1.0  
 ANGLES=±1°

APPROVED  
 CHECKED  
 DRAWN andrew  
 DRAWN DATE 03/06/23

**CHANGHONG**  
 CHANG HONG TECHNOLOGY CO., LTD.

TITLE  
 SMA FEMALE BKD CRIMP FOR 1.13 1.32

DRAWING NO.  
 SMA-02-71-I-TGG

REV A

FILE NO.