

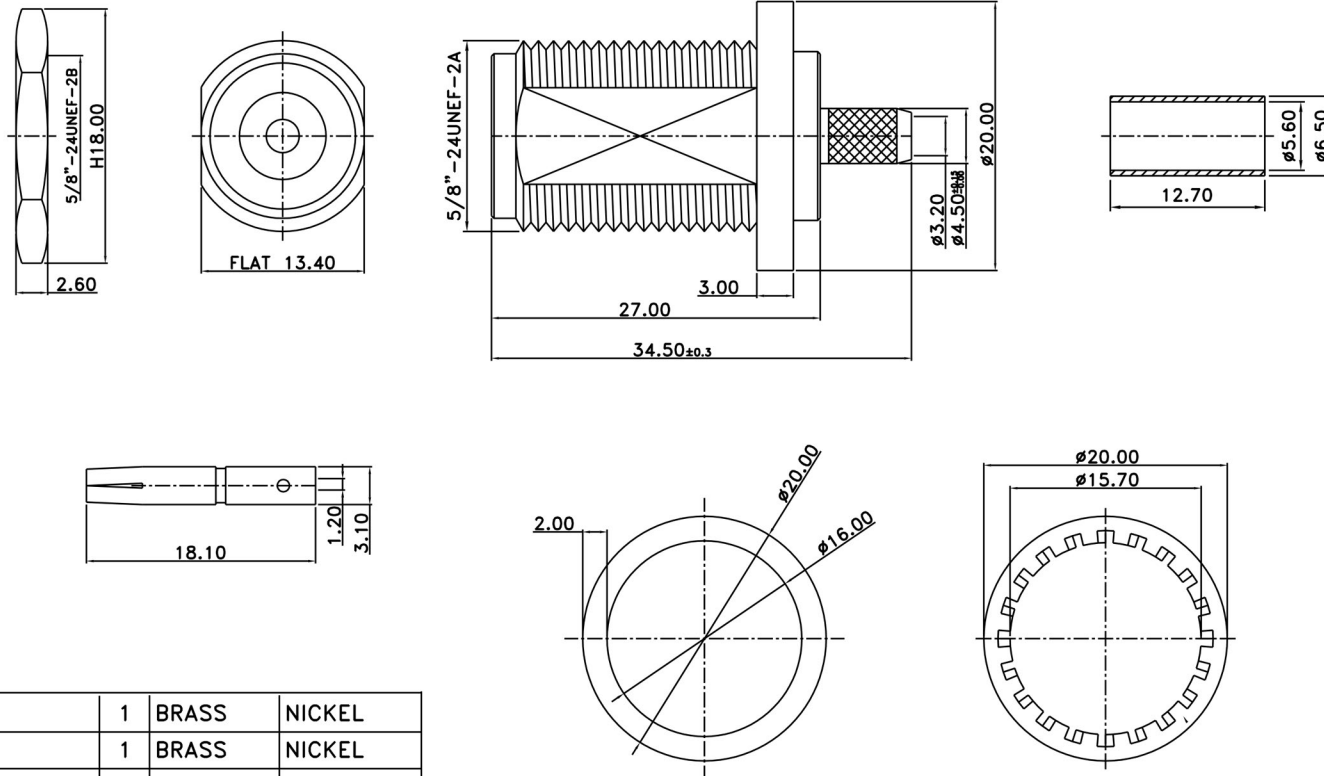

58 Wakis Avenue, Strijdompark, Randburg 2155, Johannesburg
 Tel: +27 11 791 1033 | Fax: +27 11 791 1187 | wireless@otto.co.za | www.otto.co.za

N-14-22-F2-TGN N Type bulkhead crimp jack for RG58

REV	DESCRIPTION	DRAWN	DATE



9	GAP	1	BRASS	NICKEL
8	WASHER	1	BRASS	NICKEL
7	FERRULE	1	BRASS	NICKEL
6	GASKET	1	SI-RUBBER	RED
5	SLEEVE	1	BRASS	NICKEL
4	DIELECTRIC	1	TEFLON	NONE
3	DIELECTRIC	1	TEFLON	NONE
2	PIN	1	BRASS	GOLD
1	BODY	1	BRASS	NICKEL
NO	Description	Q'ty	Material	Finish

UNLESS OTHERWISE SPECIFIED	* MAJOR DIMENSION	APPROVED
1. REMOVE ALL BURRS.	UNLESS OTHERWISE NOTED TOLERANCES	CHECKED
2. BREAK ALL CORNERS & EDGES CO.15 MAX.	0.5-6=±0.2	DRAWN
3. CHAMFER 1ST & LAST THREADS 45°	6-30=±0.4	andrew
4. DIAMETERS ON COMMON CENTERS.	30-120=±0.6	DRAWN DATE 03/06/11
TO BE CONCENTRIC WITHIN 0.1 T.T.R.	120-315=±1.0	FILE NO.
5. ALL DIMENSIONS ARE AFTER PLATING.	ANGLES=±1°	
SCALE 2/1	UNIT MM	

 <small>CHANG HONG TECHNOLOGY CO., LTD.</small>	
TITLE N FEMALE BKD CRIMP FOR RG58	
DRAWING NO. N-14-22-F2-TGN	REV A