



wireless@otto.co.za • +27 11 791 1033

OFFICIAL SOUTH AFRICAN DISTRIBUTOR



DL100EU DTU User Manual

1. General Information

DL100CN LoRa DTU is a wireless communication terminal product designed and developed to meet the needs of a large number of narrowband data transmission. DTU terminal takes 32-bit high-performance cortex M0 + microcontroller as the core, integrates Lora radio frequency front-end SX1268 and RS485 isolation modules, supports transparent transmission, and is very suitable for IOT applications with high performance and cost requirements.

1.1. Product Features

DL100CN LoRa DTU is a LoRa transparent terminal module supporting RS-485 interface, which integrates Rejeee' s Lora transparent module, wide voltage DC-DC input, RS-485 isolation interface, etc. DL100EU LoRa controller DTU can transmit point-to-point data to each other or form a star network with Rejeee gateway for data communication. Users can configure different wireless transmission power, communication frequency, communication rate, etc. according to the needs of application scenarios.

1.2. Main Features

- *Support serial port data transmission, easy to use;
- *Support wide voltage DC power supply, flexible use;
- *Built-in optocoupler and isolation to meet the complex environment;
- *LoRa technology is adopted, with long transmission;
- *Communication parameters can be flexibly configured according to requirements;
- *3.81 mm wiring terminal is used, which is convenient and reliable;
- *It can support point-to-point and star network at the same time;
- *Industrial design, interface isolation and anti electromagnetic interference design.

1.3.Parameters

No.	Parameter	Description	Note
1	Voltage	12VDC±20%/9-24V	wide voltage DC power supply
2	Power	External DC power supply	DC round head or terminal block
3	Current	Sleeping: < 2uA	Test under 12V power supply
4		Working: < 20mA	
5		TX Current: < 130mA	
6	Environment	Temp:-45℃~+ 85℃	
7		Humid: ≤95%RH	
8	Size	71*55*20mm	
9	Diameter	3mm	
10	Configuration	Through RS485	
11	Output Voltage	DC 5V	Supports one voltage output
12	Data Interface	RS485*1	
13	Isolation Voltage	3000VDC	
14	Wireless Communication	SMA Antenna Interface	
15		Frequency: 868MHz	
16		Bandwidth: 7.8~500KHz	125KHz Default
17		TX Power: 20dBm Max	
18		6 level air speed adjustable	
19		Range: 3-5KM	Visual Range
20	Indicator	Power Indicator	
21		RX/TX Indicator	

1.4.Product Appearance



2. Diagram

DL100EU adopts the microcontroller of cortex M0 + core with high performance and low power consumption as the main control, and the RS-485 interface with isolation is extended externally to realize LoRa transparent transmission. The diagram of the terminal is shown in the figure below:

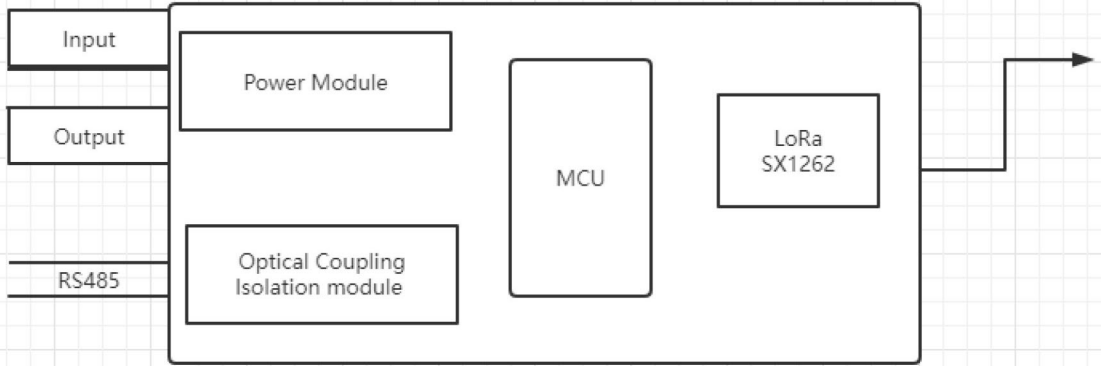

2.1.LoRa Network

DTU can support both P2P network and star network as below:

Peer to Peer network

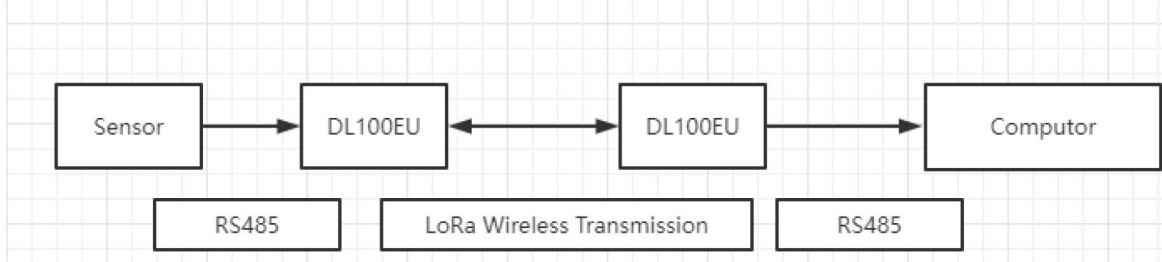

Star Network

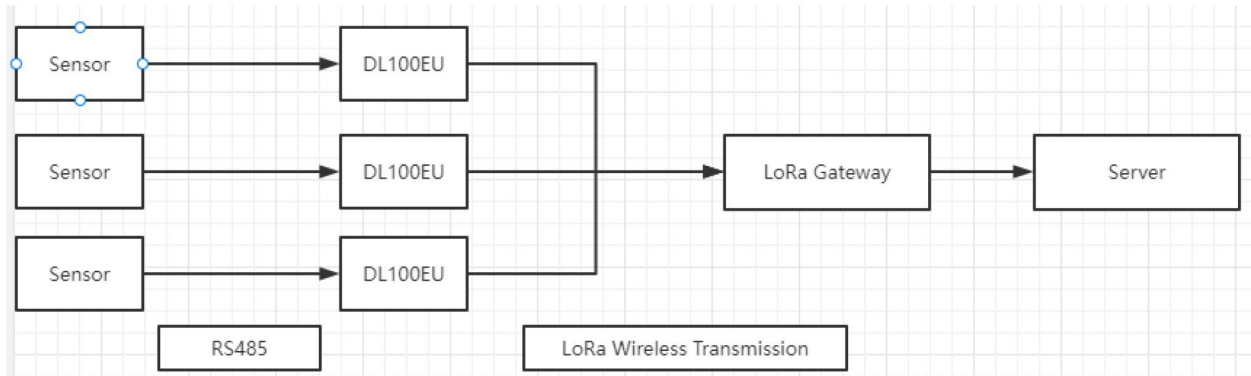

2.2.DL100CN LoRa DTU Interface

Picture of DTU as below:



2.3.Definition of terminal

DL100EU LoRa DTU definition as below

No.	Name	Type	Definition
1	VCC	P	DC Power In
2	GND	P	GND In
3	VOUT	P	DC Power Out
4	GND	P	DC GDN Out
5	A+	G	RS485 A
6	B-	G	RS485 B

2.4.Wiring Instructions

The standard DTU supports one RS-485 interface and is connected with two core cables, namely "rs485a" line and "rs485b" line. It can also be converted into RS232 interface or other interfaces through the external serial port conversion module.

The power input can be powered directly by the adapter with 2.5mm DC round head plug or through the wiring terminal, one of which can be selected.

The connector adopts plug-in wiring terminal. The signal line or power line adopts the terminal plug, and the signal lead is fixed with a cross screwdriver and directly inserted into the corresponding terminal socket of DTU.

2.5. Configuration Instructions

You can configure frequency, TX power, bandwidth etc through sensor tool, and configuration tool as below:

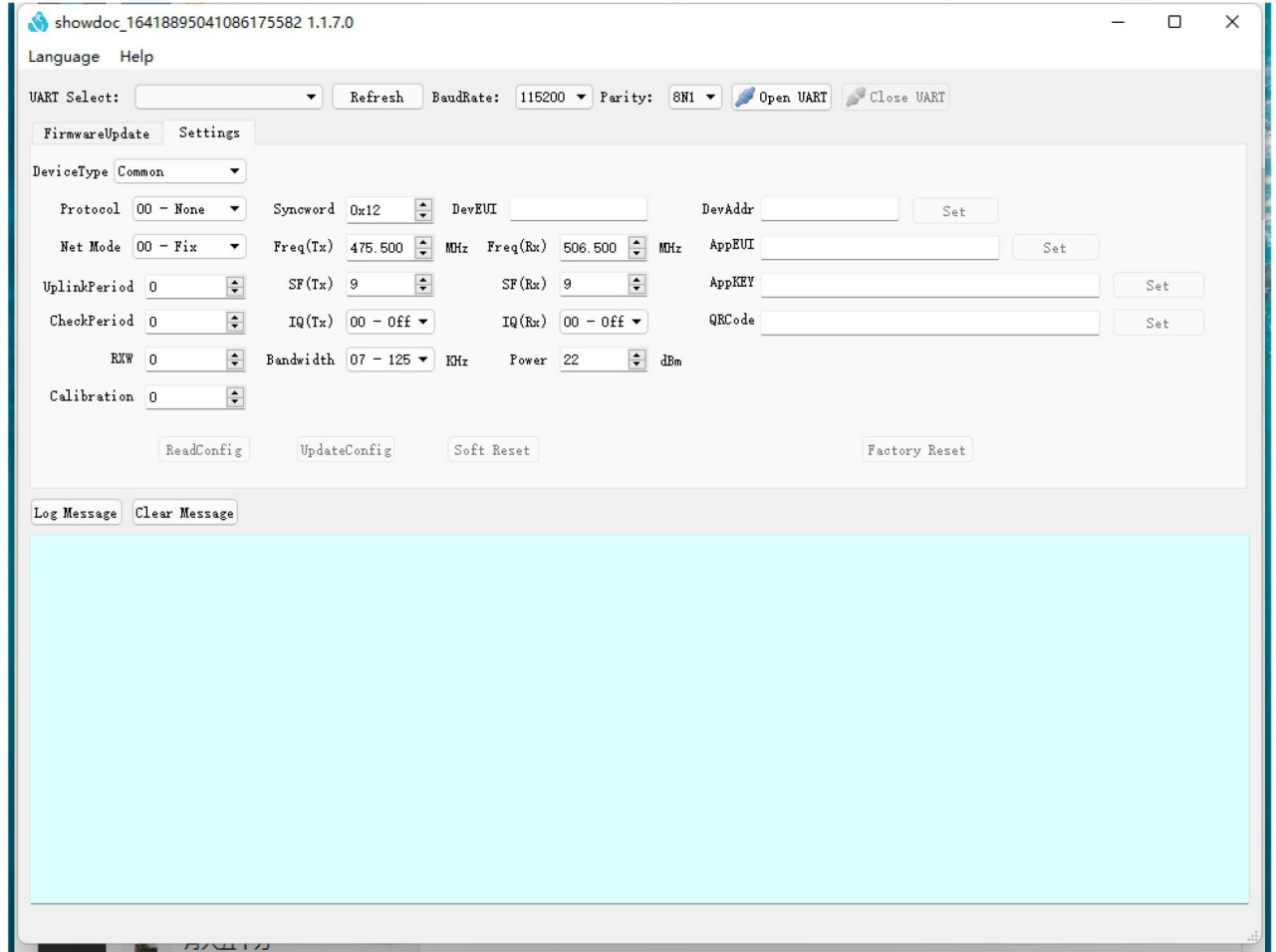

3. Installation

3.1. DL100EU LoRa DTU Installation

When get DL100EU DTU, you only need to fix the peripheral small ear hole on the installation object. If it does not need to be fixed, it can be placed horizontally.

Note: the angle of the antenna should be considered when installing the terminal. In order to ensure the signal quality between the terminal and the receiving point, it is recommended to avoid metal shielding within a certain distance in the direction of the antenna radiation field during installation.