

## BNC-15-05-F-TGN BNC crimp plug right angle RG58

REV	DESCRIPTION	DRAWN	DATE

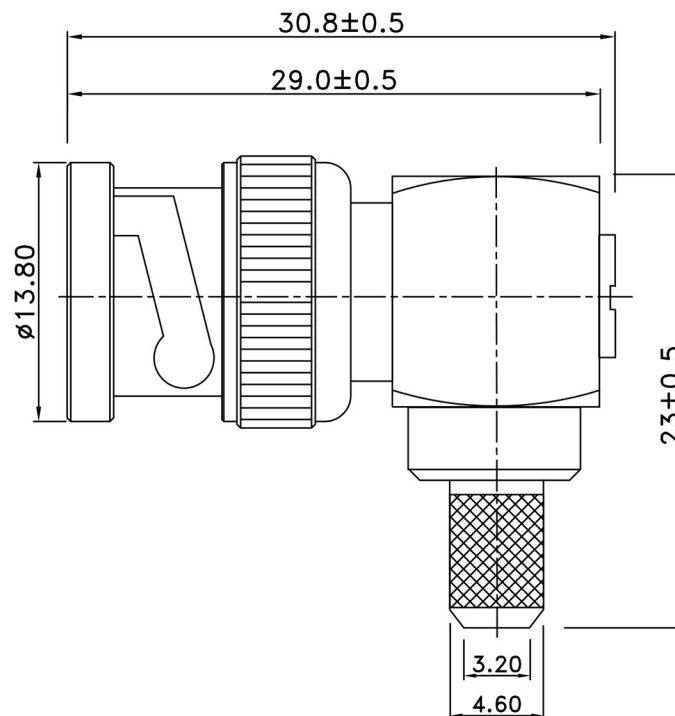
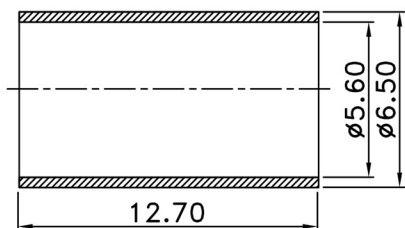

8	BODY	1	BRASS	NICKEL
7	SHELL	1	BRASS	NICKEL
6	WASHER	1	STELL	NICKEL
5	SPRING	1	SK-5	NICKEL
4	GASKET	1	RUBBER	RED
3	INSULATOR	1	TEFLON	NONE
2	RING	1	BRASS	NICKEL
1	PIN	1	BRASS	GOLD
NO	Description	Q'ty	Material	Finish

UNLESS OTHERWISE SPECIFIED  
 1. REMOVE ALL BURRS.  
 2. BREAK ALL CONNERS & EDGES CO.15 MAX.  
 3. CHAMFER 1ST & LAST THREADS 45°.  
 4. DIAMETERS ON COMMON CENTERS.  
 TO BE CONCENTRIC WITHIN 0.1 T.I.R.  
 5. ALL DIMENSIONS ARE AFTER PLATING.

\* MAJOR DIMENSION  
 UNLESS OTHERWISE NOTED TOLERANCES  
 0.5-6=±0.2  
 6-30=±0.4  
 30-120=±0.6  
 120-315=±1.0  
 ANGLES=±1°

APPROVED  
 CHECKED  
 DRAWN andrew  
 DRAWN DATE 03/07/14

  
 TITLE  
 BNC MALE R/A CRIMP FOR RG58  
 DRAWING NO.  
 BNC-15-05-F-TGN  
 REV A  
 FILE NO.