

Depending upon the operating conditions, the work environment, and many other factors, Invert-A-Bolt™ (IVB) Fasteners may experience wear and occasionally require refurbishment. The refurbishment kit consists of the elements most likely to fail: the stud, the spring, and the cover. These instructions will provide the user with detailed information to dis-assemble the product and replace the worn components.

NECESSARY TOOLS

- ADT-1-12-001 Assembly/Dis-Assembly Tool
- L-.990-.3 Washer
- PA-001-001 Press Attachment
- PA-002-001 Press Attachment
- Arbor Press
- Wire Brush

Dis-assembly & Assembly of fastener using Arbor Press

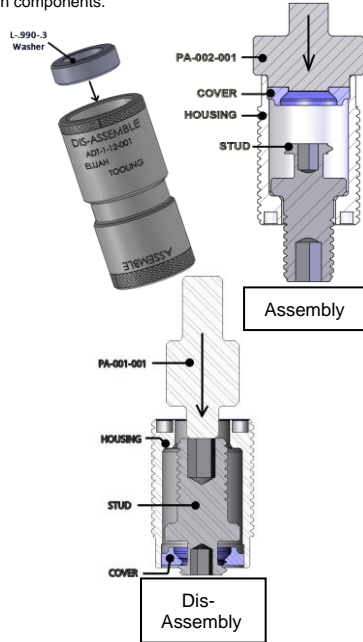
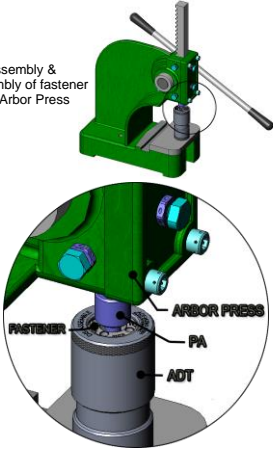

LIMITED WARRANTY

We warrant that within 90 days from the date of shipment, if the product manufactured by us and sold by us (or an authorized distributor) is in the possession of the original buyer, we will replace or repair, at our option, free of charge, any part or parts which upon examination are found to be defective in workmanship or material, and not due to normal wear, provided that, upon our request, the product or parts thereof are returned to our location, with accompanying documentation that the product has been installed, used and maintained in accordance with instructions and has not been subject to abuse. We shall not be liable or responsible for any expense or liability for repairs, additions, or modifications made upon the product without our written consent.

This warranty is in lieu of all other express or implied warranties (including without limitation any warranty of merchantability or fitness for a particular purpose.) In no event shall we be liable for any indirect, special, or consequential damages (including, but not limited to, lost profits or other damages from loss of production) caused by defective material, or by unsatisfactory performance of the product, or by any other breach of contract by us.

The Elijah Tooling, Inc. Warranty shall apply in all cases to all products manufactured by us and sold by us. Elijah Tooling, Inc. reserves the right to modify or change the design of products shown in this specification/instruction sheet, without notice. Such modifications or changes may include, but are not limited to, changes in finish, materials, specifications, etc., from descriptions and illustrations of products listed herein.

INSTALLATION INSTRUCTIONS

Install PA-001-001 press attachment into the arbor press using a set screw.

1. Screw the stud down until it "bottoms" all the way through the cover. The stud should be spinning freely in the cover.
2. Insert the washer and fastener into the ADT 1-12-001 Assembly/Dis-Assembly Tool on the Dis-Assemble side (as shown). Center ADT-1-12-001 until the stud is concentric with PA-001-001.
3. Rotate the handle of the arbor press until PA-001-001 contacts the top of the stud. Continue to rotate the handle until the press attachment pushes the stud/cover assembly out the base of the housing.
4. Return the handle to the dis-engaged position. Remove the dis-assembled fastener from ADT-1-12-001. Discard the stud, cover and spring. Soak the housing in a cleaning solution and use a wire brush (as required) to remove excess grit or grime from the threads.
5. Turn ADT-1-12-001 over so that the "Assemble" side is up.

Remove PA-001-001 & install PA-002-001 press attachment into the arbor press using a set screw.

6. Drop the housing face down into ADT-1-12-001. Take the new conical spring and insert it onto the small end of the new stud. Then drop the stud/spring assembly into the housing. Lastly, place the new cover, flat side up, into the back of the housing. The ridge side should be facing the spring.
- (Please note - do not pre-assemble the stud to the cover prior to dropping the assembly into the housing. Damage to the cover or stud may result.)**
7. Rotate the handle of the arbor press down until PA-002-001 contacts the cover. Continue to rotate the handle until the press attachment causes the cover to seat in the housing and is stopped by the outer diameter of the housing. Be careful not to apply too much force which could damage the overall length of the housing.
8. Return the handle to the dis-engaged position. Remove the fastener.
9. Screw the stud down until it is captured by the cover.
10. Assembly is complete.

For additional support, call 1-877-462-BOLT or email info@invert-a-bolt.com.

REFURB KIT

Fastener P/N: AA07-375-021RFB
Refurb kit for 3/8"-16 dia. stud x 1 1/16"-16 dia. LH housing, .210 stud stickout, 3/16" hex



Depending upon the operating conditions, the work environment, and many other factors, Invert-A-Bolt™ (IVB) Fasteners may experience wear and occasionally require refurbishment. The refurbishment kit consists of the elements most likely to fail: the stud, the spring, and the cover. These instructions will provide the user with detailed information to dis-assemble the product and replace the worn components.

NECESSARY TOOLS

- ADT-1-12-001 Assembly/Dis-Assembly Tool
- L-.990-.3 Washer
- PA-001-001 Press Attachment
- PA-002-001 Press Attachment
- Arbor Press
- Wire Brush
- Cleaning Solution

Dis-assembly & Assembly of fastener using Arbor Press

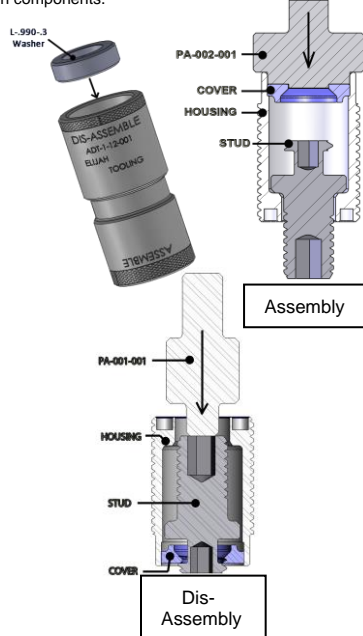
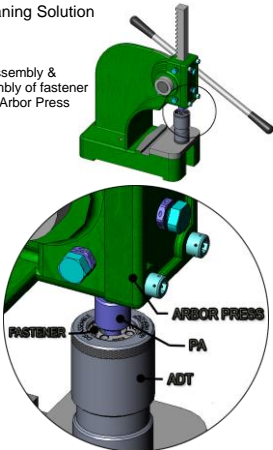

LIMITED WARRANTY

We warrant that within 90 days from the date of shipment, if the product manufactured by us and sold by us (or an authorized distributor) is in the possession of the original buyer, we will replace or repair, at our option, free of charge, any part or parts which upon examination are found to be defective in workmanship or material, and not due to normal wear, provided that, upon our request, the product or parts thereof are returned to our location, with accompanying documentation that the product has been installed, used and maintained in accordance with instructions and has not been subject to abuse. We shall not be liable or responsible for any expense or liability for repairs, additions, or modifications made upon the product without our written consent.

This warranty is in lieu of all other express or implied warranties (including without limitation any warranty of merchantability or fitness for a particular purpose.) In no event shall we be liable for any indirect, special, or consequential damages (including, but not limited to, lost profits or other damages from loss of production) caused by defective material, or by unsatisfactory performance of the product, or by any other breach of contract by us.

The Elijah Tooling, Inc. Warranty shall apply in all cases to all products manufactured by us and sold by us. Elijah Tooling, Inc. reserves the right to modify or change the design of products shown in this specification/instruction sheet, without notice. Such modifications or changes may include, but are not limited to, changes in finish, materials, specifications, etc., from descriptions and illustrations of products listed herein.

INSTALLATION INSTRUCTIONS

Install PA-001-001 press attachment into the arbor press using a set screw.

1. Screw the stud down until it "bottoms" all the way through the cover. The stud should be spinning freely in the cover.
2. Insert the washer and fastener into the ADT 1-12-001 Assembly/Dis-Assembly Tool on the Dis-Assemble side (as shown). Center ADT-1-12-001 until the stud is concentric with PA-001-001.
3. Rotate the handle of the arbor press until PA-001-001 contacts the top of the stud. Continue to rotate the handle until the press attachment pushes the stud/cover assembly out the base of the housing.
4. Return the handle to the dis-engaged position. Remove the dis-assembled fastener from ADT-1-12-001. Discard the stud, cover and spring. Soak the housing in a cleaning solution and use a wire brush (as required) to remove excess grit or grime from the threads.
5. Turn ADT-1-12-001 over so that the "Assemble" side is up.

Remove PA-001-001 & install PA-002-001 press attachment into the arbor press using a set screw.

6. Drop the housing face down into ADT-1-12-001. Take the new conical spring and insert it onto the small end of the new stud. Then drop the stud/spring assembly into the housing. Lastly, place the new cover, flat side up, into the back of the housing. The ridge side should be facing the spring.
- (Please note - do not pre-assemble the stud to the cover prior to dropping the assembly into the housing. Damage to the cover or stud may result.)**
7. Rotate the handle of the arbor press down until PA-002-001 contacts the cover. Continue to rotate the handle until the press attachment causes the cover to seat in the housing and is stopped by the outer diameter of the housing. Be careful not to apply too much force which could damage the overall length of the housing.
8. Return the handle to the dis-engaged position. Remove the fastener.
9. Screw the stud down until it is captured by the cover.
10. Assembly is complete.

For additional support, call 1-877-462-BOLT or email info@invert-a-bolt.com.

REFURB KIT

Fastener P/N: AA07-375-021RFB
Refurb kit for 3/8"-16 dia. stud x 1 1/16"-16 dia. LH housing, .210 stud stickout, 3/16" hex

