

Product:	Silicone Rubber Keyboard
Typenumber:	HT RKCT92x-W-MC1

Last Revised:	10 Sep 2019
Revision#:	00_02

RKCT92 Silicone Rubber Keyboard - External Module

Description:

The Hatteland Technology Full travel rubber Keyboard. This 92 key backlit keyboard features a compact keyboard with integrated waterproof 25 mm trackball and scroll function. The rubber keys are proven for efficient cleaning, reduced disinfection time and protection against cross contamination. The backlit keys warrant for optimized performance while working in low-light environments.

Features:

• Compact layout	92 full travel rubber keys
• Backlight	Dimmable backlight at 8 levels by two dedicated keys
• LED	Low power LED's warrant for a long life
• Test and certificate	Certificate of Conformity fully compliant with IEC60945
• Power requirements	Powered directly from USB port

Technical Specifications:

Sealing:	IP67 sealed
Keys:	92 full travel rubber keys
Pointing Device:	25 mm optical trackball
Power requirements:	Directly from USB port
Output:	1x 1.8m. USB cable (panel mount) 1x 1.6m. USB cable (enclosed)
Operating temperature:	0°C to +60°C
Switch force	210 grams
Switch stroke	2 mm

Physical Specifications:

Desktop mount dimensions:	350mm x 159mm x 36mm
Desktop mount Weight:	0.6kg/1.32lbs
Panel mount dimensions:	354.5mm x 163.5mm x 38.6mm
Panel mount weight:	0.7kg/1.54lbs

Illustrations for desktop mount

HT RKCT92S-W-MC1

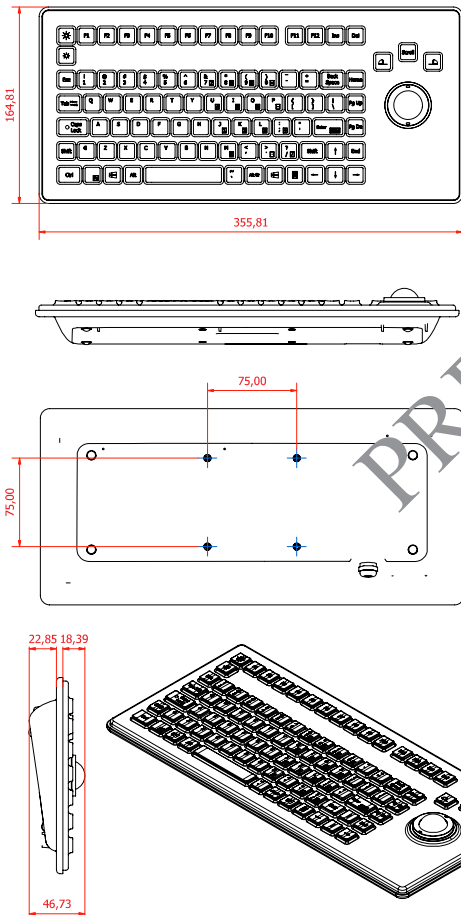

Illustrations for panel mount

HT RKCT95F-W-MC1

Drawings pending

Dimensions might be shown with or without decimals and indicated as mm [inches]. Tolerance on drawings is +/- 1mm. For accurate measurements, check relevant DWG file.