

PROPORTIONAL
With ACTIVE CALIBRATION

THE POWER OF

REDARC®

Tow-Pro™
Elite

Electric Trailer Brake Controller

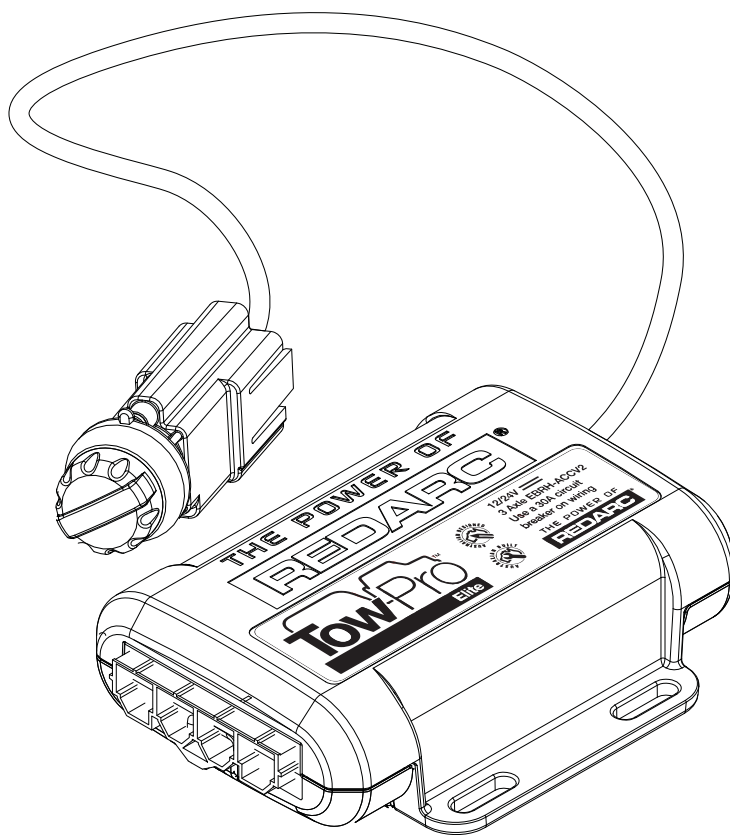

AL-KO ESC &
DEXTER DSC
APPROVED*

TOW-PRO™ ELITE (EBRH-ACCV2) TRAILER BRAKE CONTROLLER

The Tow-Pro™ Elite is an electric trailer brake controller designed to suit most common trailer braking applications whilst requiring minimal dash space and being simple to install and operate.

The Tow-Pro™ Elite offers selectable Proportional or User Controlled trailer braking modes allowing the user to choose the braking style depending on the road or terrain conditions, vehicle type, or driver preference.

The Tow-Pro™ Elite features Active Calibration which constantly monitors the direction of travel and will even calibrate with no trailer attached whilst maintaining the ability to mount in any orientation.

The unit is able to operate both electric and electric/hydraulic trailer brakes and will operate from either 12V or 24V vehicle systems without the need for manual selection or extra components/ wiring. The unit is ADR compliant when installed as directed and is approved for use with AL-KO ESC and Dexter DSC sway control systems.

WARNINGS & SAFETY INSTRUCTIONS

SAVE THESE INSTRUCTIONS - This manual contains IMPORTANT SAFETY INSTRUCTIONS for the Tow-Pro™ Elite Brake Controller.

DO NOT OPERATE THE CONTROLLER UNLESS YOU HAVE READ AND UNDERSTOOD THIS MANUAL AND THE CONTROLLER IS INSTALLED AS PER THESE INSTALLATION INSTRUCTIONS.

⚠ WARNING

ENSURE THAT YOUR TRAILER BRAKES ARE INSTALLED AND ARE OPERATING CORRECTLY: IMPROPERLY INSTALLED AND/OR FAULTY TRAILER BRAKES CAN CAUSE ERRATIC VEHICLE OR TRAILER BEHAVIOUR WITH THE POTENTIAL TO CAUSE A ROAD ACCIDENT. FOR THIS REASON, IT IS OF UTMOST IMPORTANCE THAT YOUR TRAILER BRAKING SYSTEM BE INSTALLED/ MAINTAINED BY A QUALIFIED INSTALLER.

ALWAYS CHECK BRAKES AT LOW SPEED EACH TIME A TRAILER IS ATTACHED TO YOUR VEHICLE.

⚠ CAUTION

1. Ensure that the Tow-Pro™ Elite is mounted securely in a fixed location. Failure to mount securely will result in inaccurate braking force measurements and incorrect braking of the trailer.
2. Ensure that the Tow-Pro™ Elite is installed inside the vehicle cabin and away from any environmental conditions that may cause damage, including engine heat, submersion in water, salt spray and humidity. Exposure to these conditions may cause damage to the unit's circuitry and may cause erratic trailer braking.

WARNINGS & SAFETY INSTRUCTIONS

3. A Fuse or Circuit Breaker of appropriate rating must be installed to protect the vehicle system. Please refer to the installation instructions on page 7 for specific instructions on where to install the Fuse or Circuit Breaker and for appropriate Fuse or Circuit Breaker rating. The Fuse or Circuit Breaker must be installed as close as possible to the battery.
4. Ensure the remote head push-button activates correctly when installed into surfaces with a thickness greater than 3.0mm. Failure to activate correctly would result in not being able to activate the override function or change modes.
5. Ensure that the cable used to install the Tow-Pro™ Elite is of adequate gauge to supply the required current to operate the trailer brakes. Incorrect wiring can result in overheated wires or excessive voltage drop and may cause injury to persons, damage to the Tow-Pro™ Elite and/or damage to property.
6. The Tow-Pro™ Elite is suitable for all trailers with electric brakes on up to three axles. Note that for trailers above 4.5t gross, special testing is required under Australian Design Rules. For these trailers, please consult with an automotive safety engineer before using the Tow-Pro™ Elite.

NOTICE

1. Ensure that a correct grounding point is used. Vehicles often have ungrounded metal reinforcements under the dash and these points are not suitable grounds. Bad grounding of the unit will result in poor or no operation.
2. The Tow-Pro™ Elite does not act as a trailer lights voltage converter. The Tow-Pro™ Elite is designed to operate the trailer brake lights under certain conditions. If the trailer brake lights require a different voltage to the input from the vehicle, damage to the trailer brake lights may result.
3. When installing the Tow-Pro™ Elite Remote Control to a thin panel, washers are recommended to reinforce the structure of the panel.
4. Do NOT exceed Tow Vehicle and Trailer weights and specifications. Failure to abide by the towing regulations, including maximum loads, may result in a fine, or in case of an accident, refusal of the insurance claim, and the possibility of further legal action. If the tow vehicle or trailer's maximum load is exceeded, police and transport authorities have the power to order the combination off the road until the issue is corrected. This may necessitate leaving the trailer on the side of the road while a vehicle with suitable towing capacity is sourced or the trailer load is reduced. Please contact your local authorities for further information.

CONTENTS

Table of Contents	Page
1 - Specifications	3
2 - Installation	5
2.1 - Mounting the main unit	5
2.2 - Wiring the brake controller	6
2.2.1 Red Wire (Vehicle Brake light) Connection	6
2.2.2 Wiring Diagrams	7
2.3 - Mounting the Remote Head	8
2.4 - Active Calibration	9
3 - Operation	10
3.1 - Adjusting the Braking Force	10
3.2 - Manual Override	10
3.3 - Operating Modes	11
3.3.1 - Proportional Mode (Blue LED)	11
3.3.2 - User Controller Mode (Green LED)	11
3.3.3 - Changing Modes	12
3.4 - Park Brake Feature	12
3.5 - Electric / Hydraulic Brakes	13
3.6 - 24V Vehicle Systems	13
3.7 - Visual User Guide	14
3.8 - LED Indication	15
3.9 - Troubleshooting	16
4 - Periodic Maintenance / Checks	19
5 - Frequently Asked Questions	20
6 - Notes	21
7 - Two Year Product Warranty	22

SPECIFICATIONS

Part Number	EBRH-ACCV2	
Operating Voltage	9V - 32V	
Nominal Input System Voltage	12V	24V
Brake Input Signal Voltage	OFF: 0V ON: +12V nominal	OFF: 0V ON: +24V nominal
Brake Coil Voltage	12V	12V
Max. Trailer Axles	3 Axles	3 Axles
Nominal Current Draw	18A	18A
Max. Rated Current	25A	30A
Standby Current	<10mA	
Operating Temp	-20°C to +60°C	
Weight	200g	
Warranty	2 years	

1 SPECIFICATIONS

Kit Contents

1. Remote Head Assembly
2. Main Unit
3. Remote Head Nut
4. Remote Head Knob
5. Remote Head Bezel
6. RJ45 Remote Head Cable (1m)
7. Main Unit Wires & Connector (0.5m)

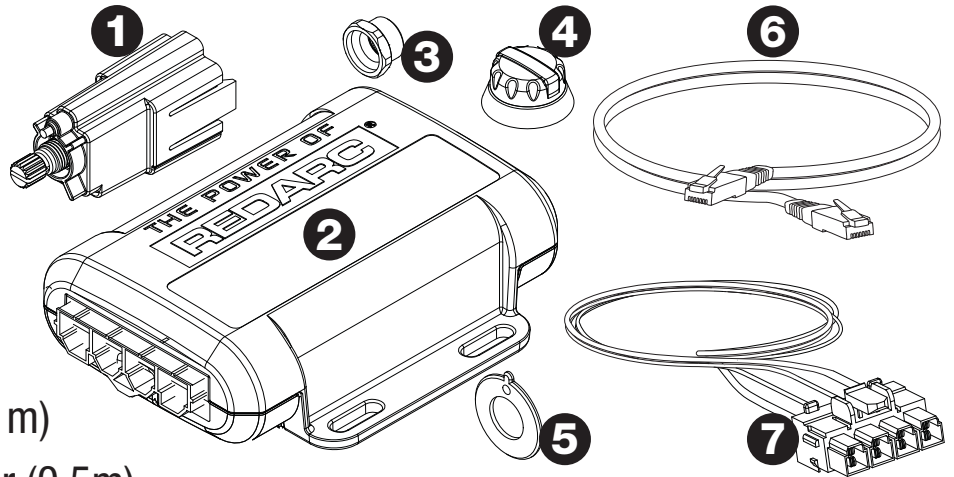

Dimensions & Connection

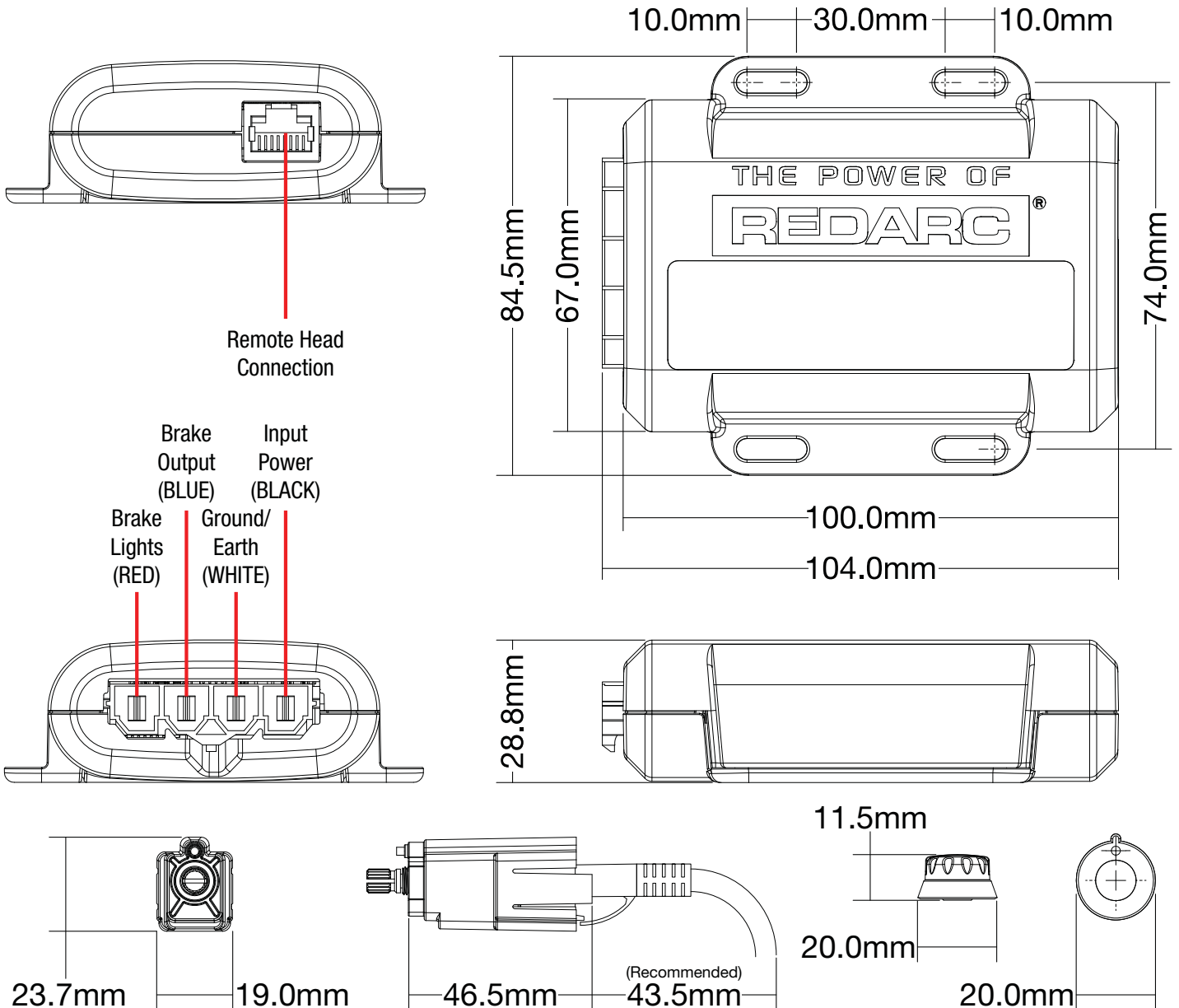

2 INSTALLATION

2.1 Mounting the main unit

The Tow-Pro™ Elite should be mounted inside the vehicle cabin using either M4 screws or other secure fitting methods at the mounting points provided. It is essential to mount the unit in a location which allows access to the intended remote head location.

The Tow-Pro™ Elite can be mounted in any orientation as long as the installation is secure and the main unit cannot move or change orientation once installed. A change of orientation will affect the system calibration.

⚠ CAUTION

Ensure that the Tow-Pro™ Elite is mounted securely in a fixed location. Failure to mount securely will result in inaccurate braking force measurements and incorrect braking of the trailer.

⚠ CAUTION

Ensure that the Tow-Pro™ Elite is installed inside the vehicle cabin and away from any environmental conditions that may cause damage, including engine heat, submersion in water, salt spray and humidity. Exposure to these conditions may cause damage to the unit's circuitry and may cause erratic trailer braking.

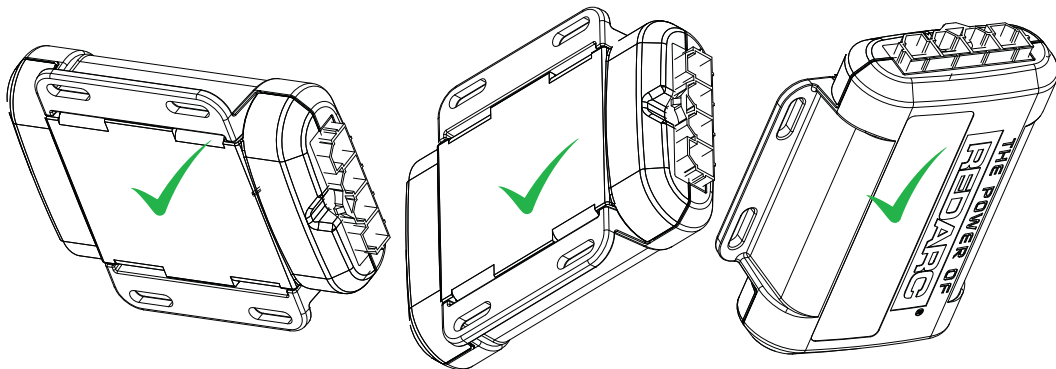

Any Secure Orientation OK

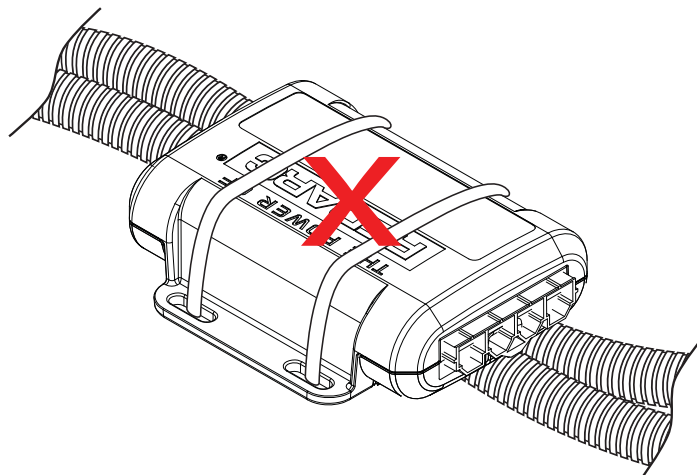

Do Not Mount to Cables / Wiring Looms

2.2 Wiring the brake controller

⚠ CAUTION

A Fuse or Circuit Breaker of appropriate rating must be installed to protect the vehicle system. Please refer to the installation instructions on page 7 for specific instructions on where to install the Fuse or Circuit Breaker and for appropriate Fuse or Circuit Breaker rating. The Fuse or Circuit Breaker must be installed as close as possible to the battery.

⚠ CAUTION

Ensure that the cable used to install the Tow-Pro™ Elite is of adequate gauge to supply the required current to operate the trailer brakes. Incorrect wiring can result in overheated wires and may cause injury to persons, damage to the Tow-Pro™ Elite and/or damage to property.

NOTICE

The Tow-Pro™ Elite does not act as a trailer lights voltage converter. The Tow-Pro™ Elite is designed to operate the trailer brake lights under certain conditions. If the trailer brake lights require a different voltage to the input from the vehicle, damage to the trailer brake lights may result.

2.2.1 Red Wire (Vehicle Brake light) Connection

The requirements for a suitable connection of a brake controller trigger wire are quite specific. This connection point must:

- Provide battery voltage output while the vehicle brakes are applied.
- Have 0 volts output while the vehicle brakes are not applied
- Accept battery voltage input when the brake controller manual over-ride is operated and illuminate at least the trailer brake lights.
- Accept the battery voltage input as above without causing any damage, spurious vehicle operation or erroneous fault indication.

A relay should not be installed to drive the red wire as this would prevent the override feature from working and may introduce dangerous voltage spikes.

For many vehicles, the brake light terminal of the trailer lighting socket provides a suitable connection, however this is not necessarily suitable for all vehicles. Unfortunately REDARC cannot recommend where to make this connection on a specific vehicle's OEM wiring. For further information contact the vehicle manufacturer.

2 INSTALLATION

2.2.2 Wiring Diagrams

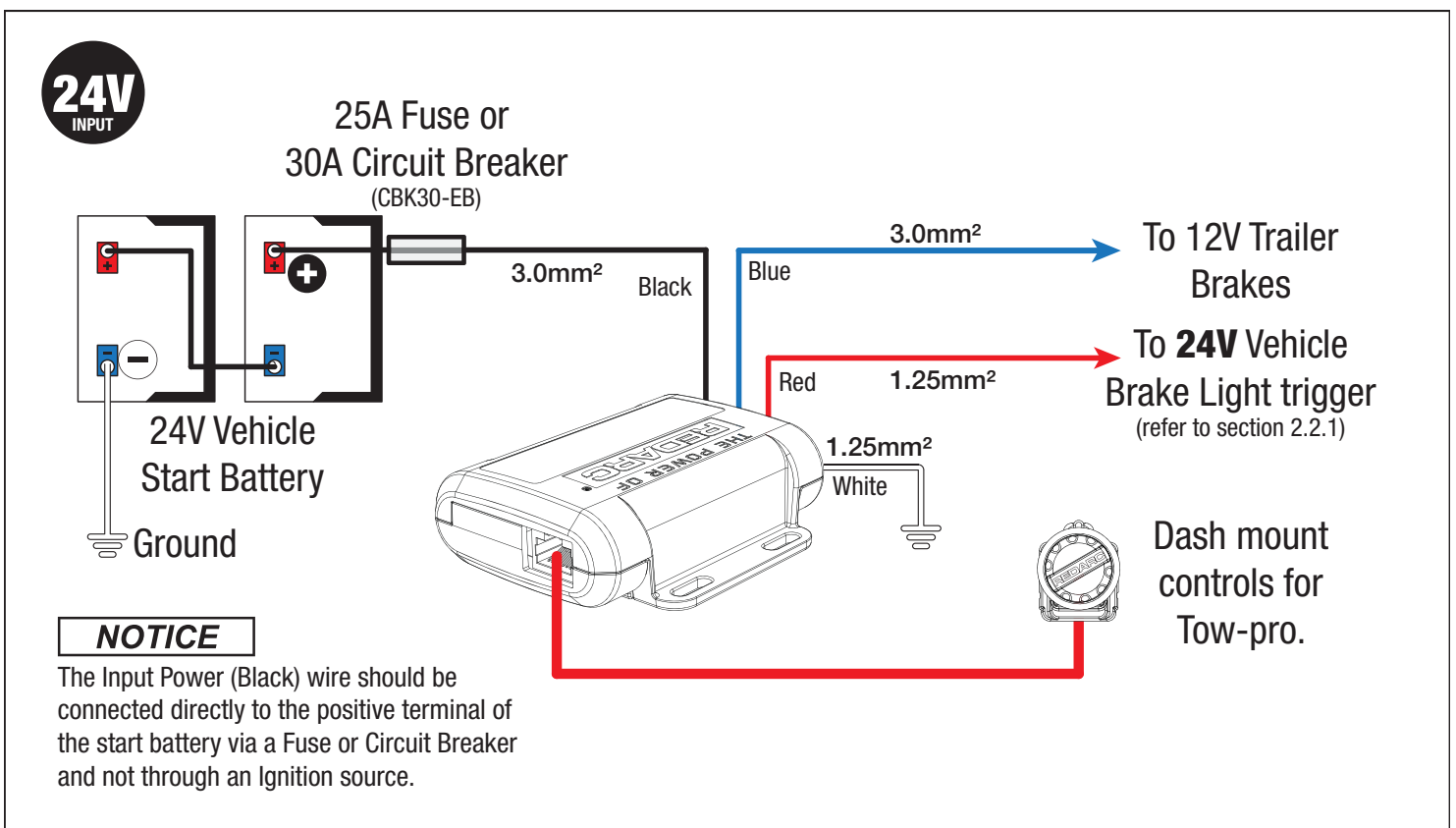
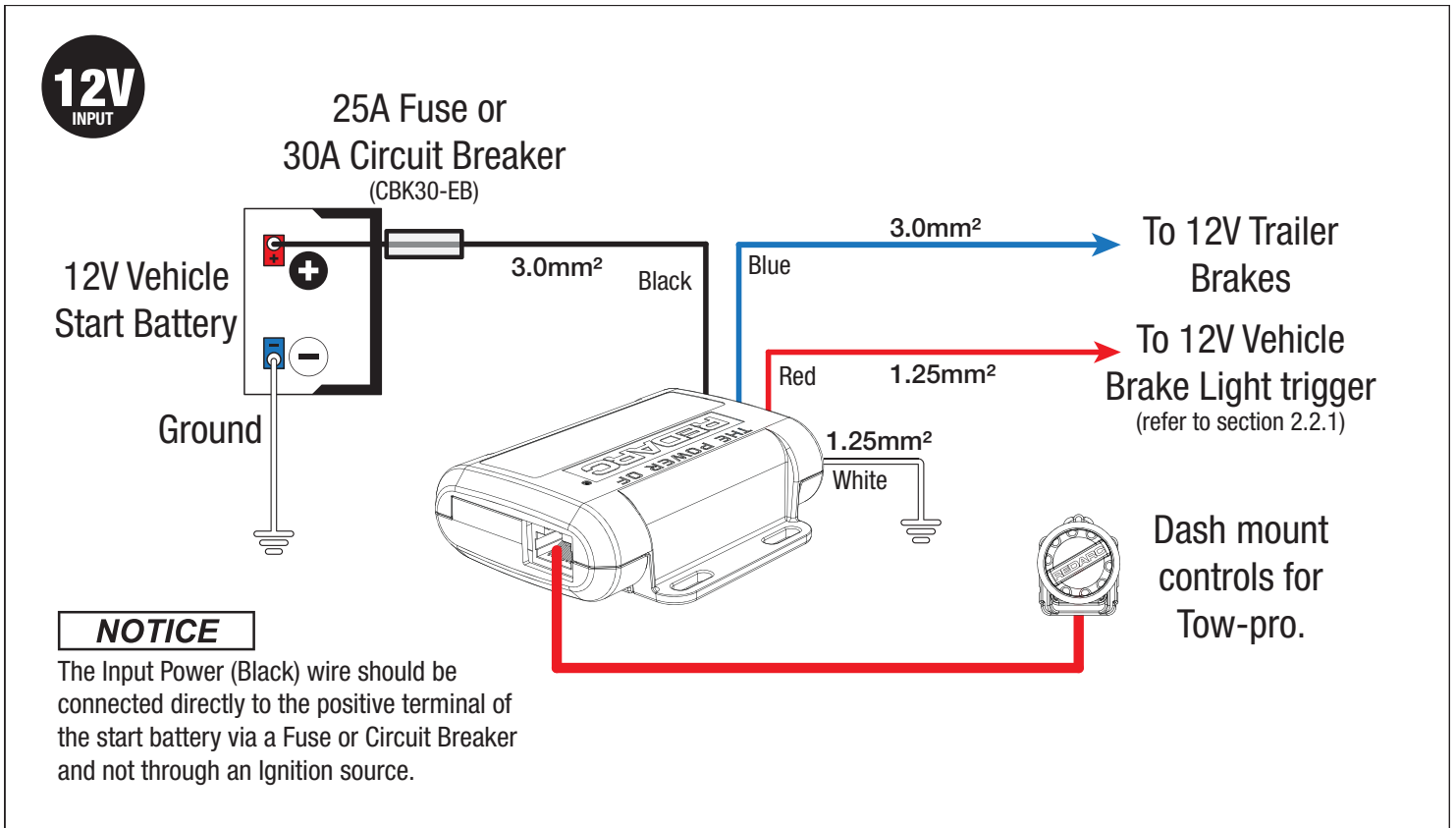

2 INSTALLATION

2.3 Mounting the Remote Head

The Tow-Pro™ Elite remote head is designed to be mounted at a distance from the main unit, allowing for a neat, convenient installation and not impeding on lower leg airbags or driver leg room. The Tow-Pro™ Elite remote head is designed to be mounted on or around the vehicle dashboard and when installed correctly, complies with Australian Design Rule (ADR) 21, which sets requirements for devices mounted on the dashboard. The Tow-Pro™ Elite remote head can be mounted directly to the dashboard, to the centre console or through a spare knock-out switch panel and requires only two holes to be drilled as per the below diagram.

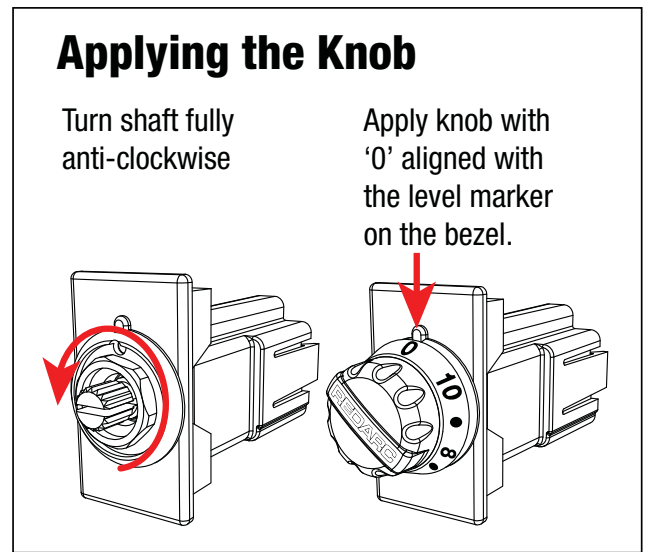
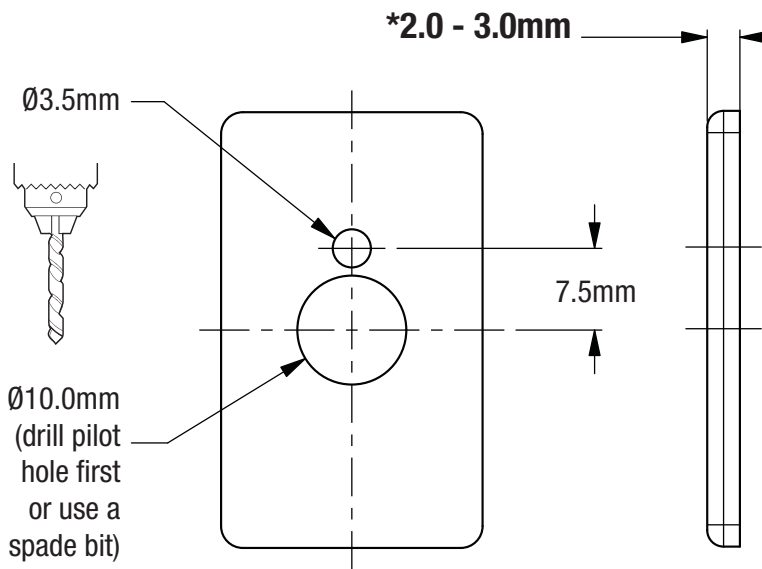

⚠ CAUTION

Ensure the remote head push-button activates correctly when installed into surfaces with a thickness greater than 3.0mm. Failure to activate correctly would result in not being able to activate the override function or change modes.

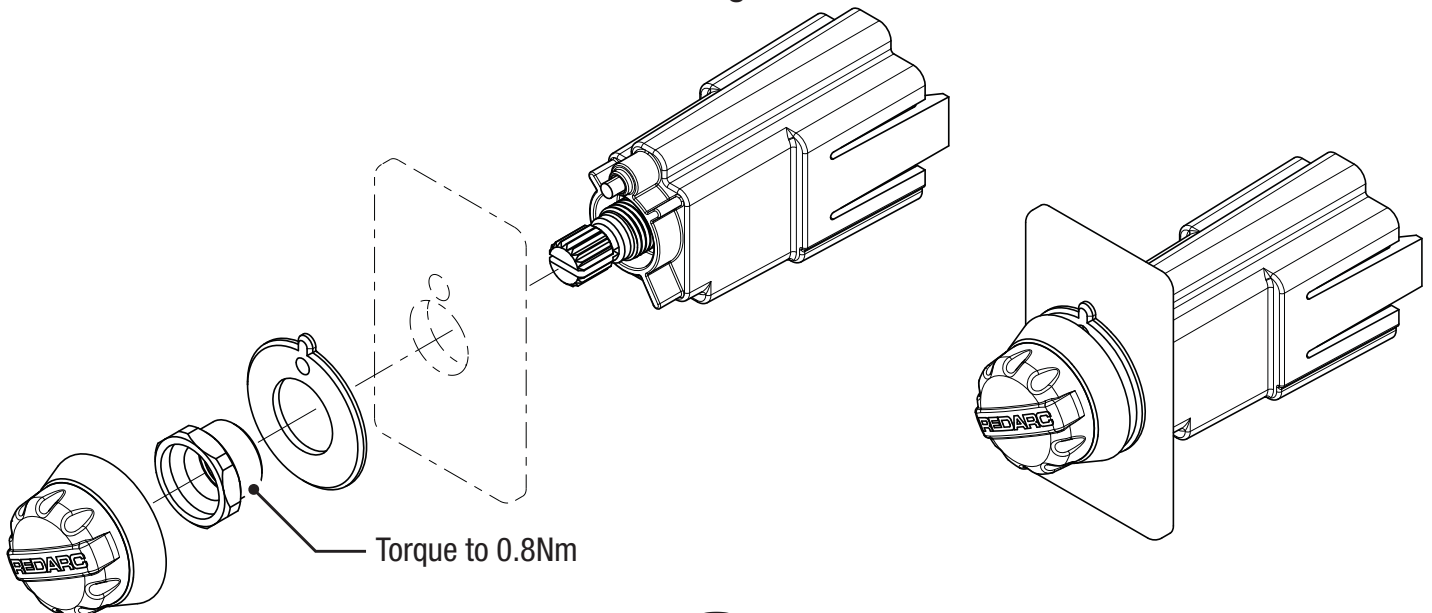

2.4 Active Calibration

When the unit is first powered, Active Calibration must first become confident in the vehicle direction of travel. Until this time the LED will flash Blue/Green.

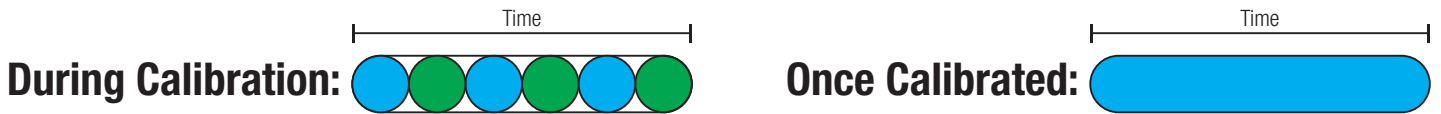

Active Calibration constantly monitors the vehicle's direction of travel and allows the Tow-Pro™ Elite to 'learn' and continuously confirm its mounting orientation. This process occurs whilst the vehicle is moving and the brake is applied and will occur with or without a trailer connected.

When the Tow-Pro™ Elite is first installed it will begin learning its mounting orientation through Active Calibration as soon as you start driving, at this point Proportional Mode is selected but not yet fully operational.

Until the Tow-Pro™ Elite has determined its mounting orientation the unit will function as if in User-Controlled mode, this is indicated by the LED glowing green with blue flashes. As the Tow-Pro™ Elite becomes more confident of its direction of travel the length of the Blue flash will increase, to the point that the LED is solid Blue which indicates it is now operating completely in Proportional mode.

Under normal driving conditions the Tow-Pro™ Elite will learn its mounting orientation within 20 brake applications. Note that the braking must be perceptible (applying the brake while stopped will not assist calibration).

If power is disconnected (for example, if the vehicle battery is changed) calibration memory will be lost and the unit will recalibrate itself using active calibration. This is similar to a radio losing its clock or preset station memory.

NOTICE

If no trailer is connected, Active Calibration will occur as normal without any indication from the LED. The LED will already be Blue when the trailer is connected. Essentially, whether a trailer is connected or not, just drive normally and Active Calibration will ensure the Tow-Pro™ Elite learns the correct direction of travel.

3 OPERATION

3.1 Adjusting the Braking Force

In both modes the braking level can be adjusted to suit varying trailer loads, braking requirements or user comfort by adjusting the control knob on the remote head.

The lower end of the scale (below level 5) should be used as a starting point and adjusted accordingly once braking requirements are established.

If a lighter braking level is required, turn the control knob to a lower number (anti-clockwise) to reduce the trailer braking force. Similarly, turn the gain control knob to a higher number (clockwise) to increase the trailer braking force.

The braking level will be indicated by the LED changing to a shade of RED when the brakes are applied. The higher the braking level, the more RED the LED will glow.

A setting of '0' will result in no trailer braking output.

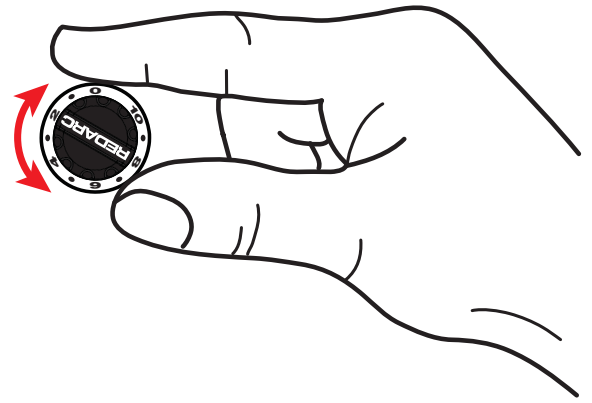

3.2 Manual Override

Pressing the gain control knob whilst driving will apply the manual override brake. The manual override brake will apply the trailer brakes only; if wired correctly will also apply the trailer brake lights and will turn the LED indicator a shade of RED. Depending on the vehicle wiring it may possibly also apply the vehicle brake lights. The manual override is designed to be used when the trailer brakes need to be applied without the vehicle brakes, such as correcting trailer 'sway' whilst travelling.

In **Proportional** mode the manual override will apply the trailer brake to a level equivalent to 'light' vehicle braking.

In **User Controlled** mode the manual override will apply the trailer brakes to the level set on the gain control knob.

In both modes the braking force can be adjusted by turning the gain control knob, either higher or lower, even whilst applying the manual override brakes.

Manual override should not be used in place of the regular vehicle brakes.

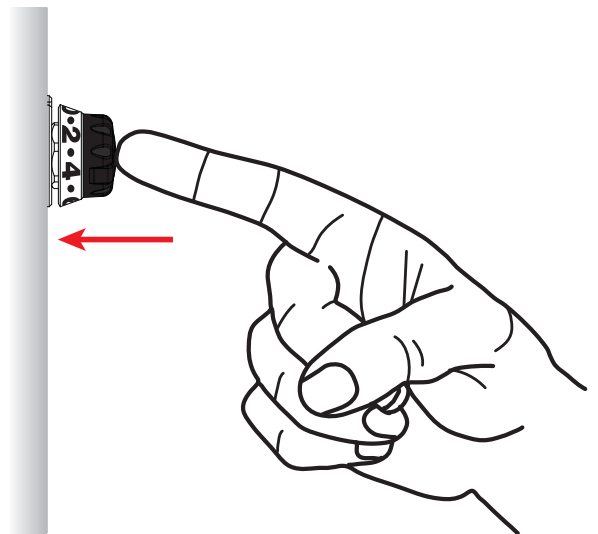

3.3 Operating Modes

The Tow-Pro™ Elite offers two modes of operation - **Proportional** and **User Controlled**. On the first application of power to the black wire, the Tow-Pro™ Elite will start-up in Proportional mode. Every time a trailer is connected, the Tow-Pro™ Elite will start up in the mode that was last selected (provided the black wire has remained connected to power/battery positive).

3.3.1 Proportional Mode (Blue LED)

If the status indication LED on the control knob is glowing BLUE, the Tow-Pro™ Elite is in **Proportional Mode**.

In Proportional Mode, the Tow-Pro™ Elite will apply the trailer brakes at a level proportional to the vehicle deceleration. The control knob setting, 0 to 10, will set the brakes from a lighter to a heavier trailer brake application. Simply put, ***the harder the vehicle brakes are applied, the harder the trailer will brake***. This mode is designed for highway travelling or everyday use and requires minimal input from the user whilst travelling.



3.3.2 User Controlled Mode (Green LED)

If the status indication LED on the control knob is glowing GREEN, the Tow-Pro™ Elite is in **User Controlled Mode**.

In User Controlled Mode, the Tow-Pro™ Elite will apply the trailer brakes to the level set by the user on the gain control knob. The control knob setting, 0 to 10, will set the brakes from Zero to Full trailer brake application. Simply put, ***the trailer will brake to the level set by the control knob (regardless of how hard the vehicle brakes)***. This mode is often preferred for off road or precision use and may require frequent attention from the user.



NOTICE

It is important to consider the road surface and conditions when selecting a mode and level setting. When changing conditions we advise to review your controller settings and adjust according to your preference.

3.3.3 Changing Modes

Changing modes can only be completed with a trailer connected. Ensure the vehicle has come to a complete stop before beginning the mode change process.

Changing between modes requires the user to complete the following process:

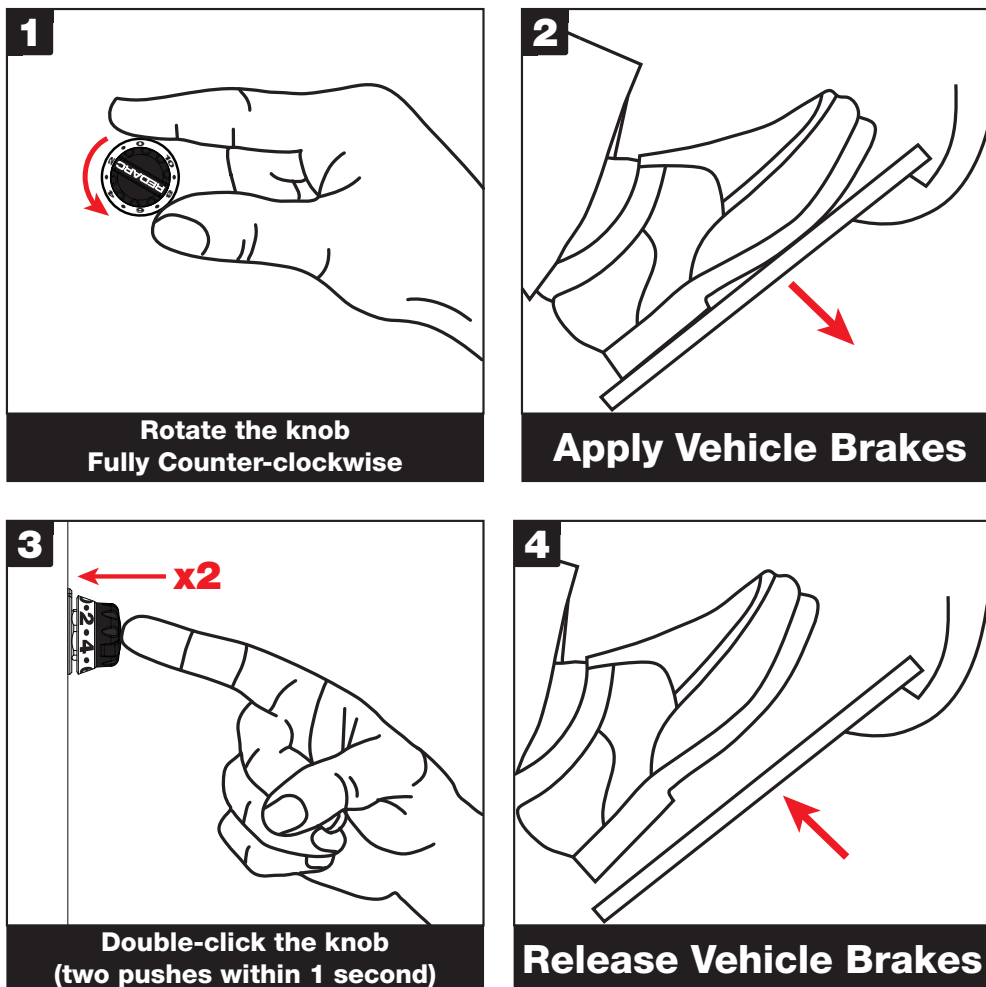

NOTICE

If you're unable to change modes, check that the remote head is not installed into a surface which is too thick and that the button is able to be depressed fully. Refer to section 2.3 for details. Ensure you reset the dial to a suitable braking level after changing modes.

3.4 Park Brake Feature

If the Tow-Pro™ Elite detects that the vehicle brakes are applied for longer than 3 seconds whilst the vehicle is stationary, it will apply the trailer brakes in an intelligent manner to reduce the required braking effort whilst decreasing the risk of rolling forward or backward whilst stopped. If the controller determines the trailer brakes are not required to keep the vehicle stationary, the output will be decreased to Zero.

3 OPERATION

3.5 Electric / Hydraulic Brakes

The Tow-Pro™ Elite is designed to operate both electric and electric / hydraulic braking systems in both Proportional and User Controlled Modes. The unit requires no user input to select the electric/hydraulic mode.

Most Electric / Hydraulic braking systems will require a separate 12V power feed for the hydraulic pump. For example:

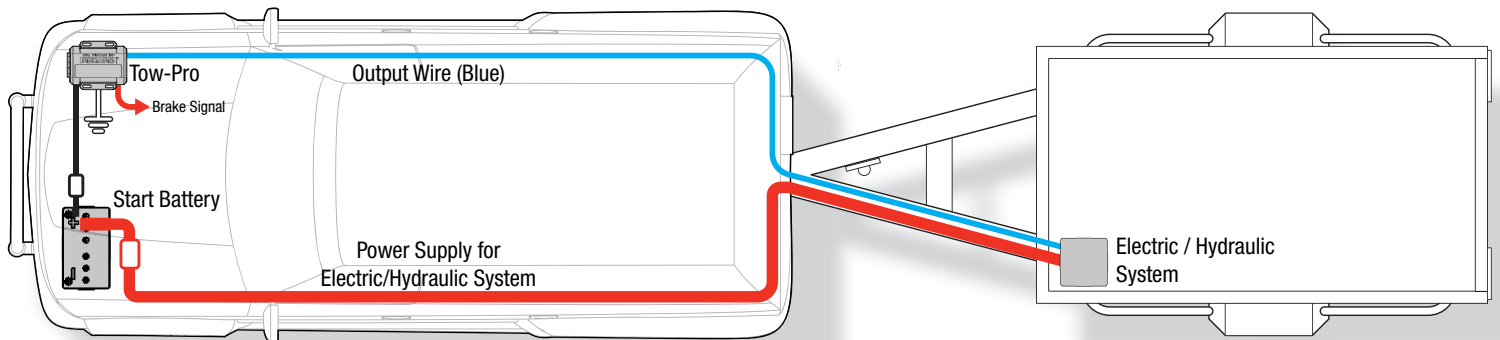

NOTICE

Always refer to the manufacturer's specifications for your Electric / Hydraulic Braking system prior to installation and usage of the Tow-Pro™ Elite.

3.6 24V Vehicle Systems

The Tow-Pro™ Elite is designed to operate 12V trailer brakes from both 12V and 24V vehicle electrical systems; The acceptable voltage input range is between 9V and 32V.

The Tow-Pro™ Elite will operate from a 24V electrical system without the need for other external devices.

For 24V installation, refer to section 2.2 'Wiring the brake controller'.

3.7 Visual User Guide

Proportional Mode

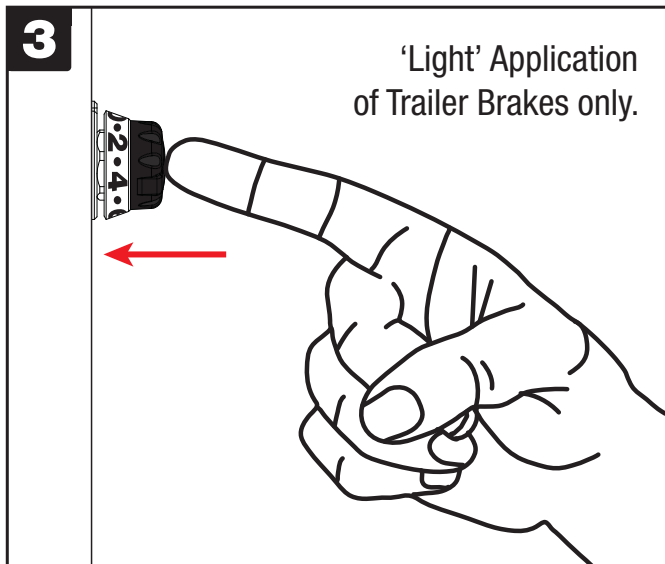
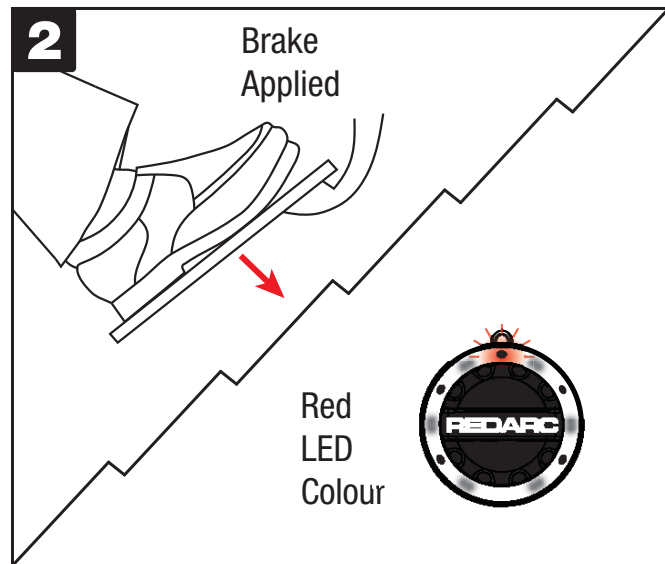
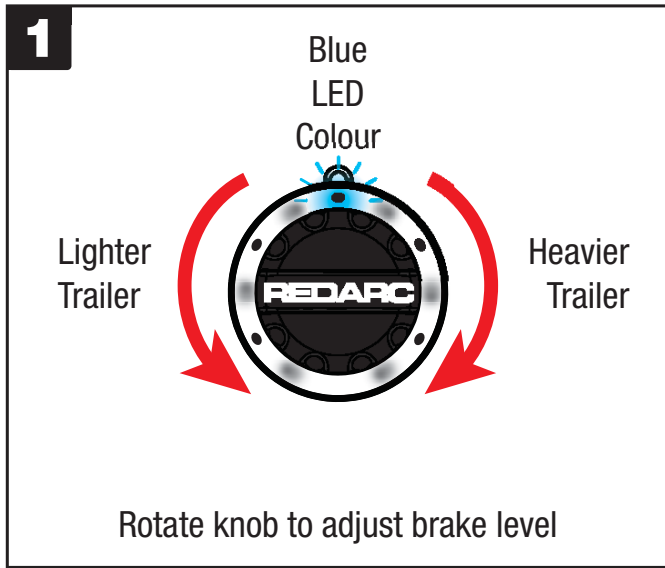

User Controlled Mode

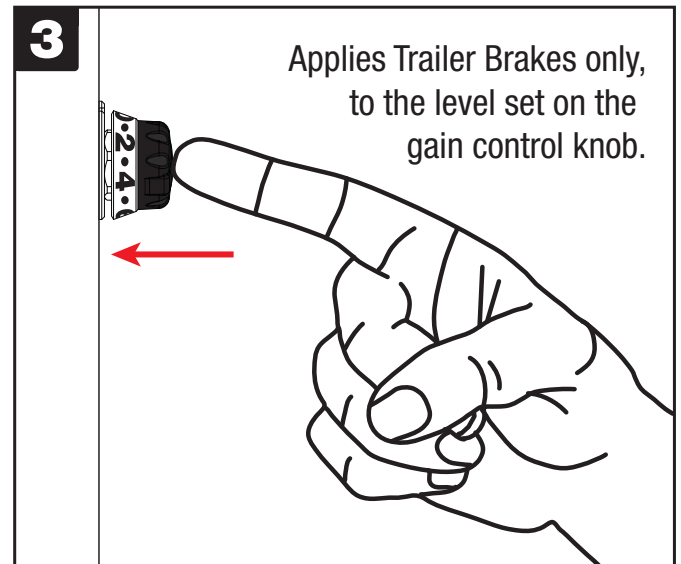
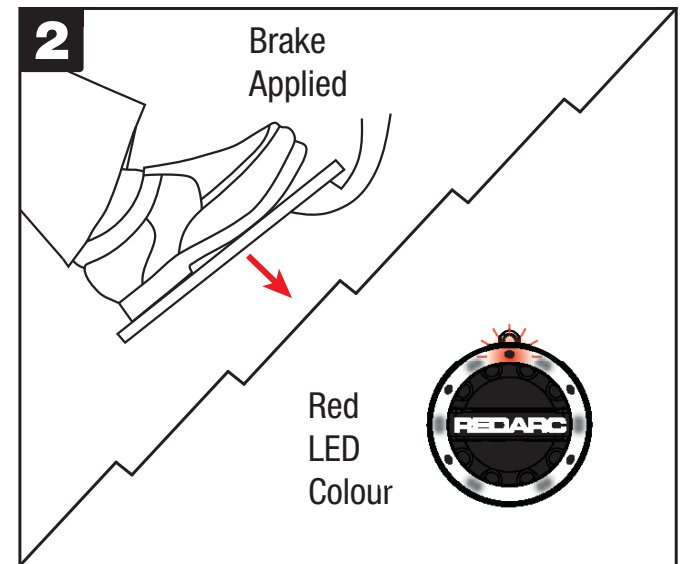
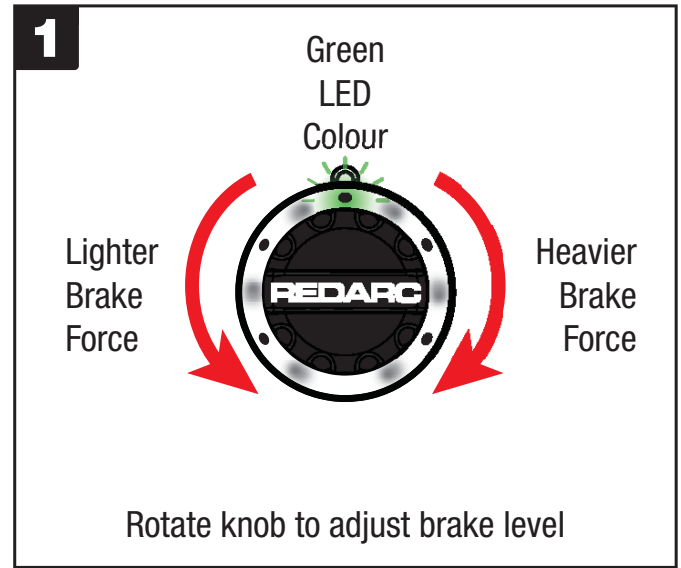

3 OPERATION

3.8 LED Indication

The Tow-Pro™ Elite will indicate both Mode and Fault Condition through colour and flash sequences of the LED indicator. The table below shows how the Tow-Pro™ Elite will indicate Normal Operation of the unit.

NOTE: LEDs will glow full brightness when gain control is adjusted or manual override is pressed. After release of the gain control knob the LED brightness will reduce. This is designed to be less intrusive on driver's vision at night.

Status			Indication		
Mode	<i>Proportional</i>	<i>User Controlled</i>			
Calibration	Blue/Green flashing	Not Applicable			
Sleep Mode ¹	Blue Breathing on button push ²				
Trailer Connected	Solid Blue	Solid Green			
Braking	Blue to Red ³	Green to Red ³			

1. Sleep Mode occurs when there is no trailer connected to the vehicle.

2. Breathing, as opposed to flashing, is the LED gradually getting brighter until its brightest point and then gradually dimming until off.

3. The LED will vary between the Mode Colour (Blue or Green) and Red depending on the braking force.

3.9 Troubleshooting

The Tow-Pro™ Elite features sophisticated diagnostics to warn the operator of faults in the vehicle and trailer brake wiring. Wiring faults are indicated by a series of colour coded flash patterns on the Tow-Pro™ Elite LED.



Most faults turn out to be something simple such as a poor connection from a dirty trailer socket, however a fault indication should not be ignored! It is a warning; if left unattended such wiring faults can become worse and may lead to deterioration or loss of trailer braking.

Please refer to the table on pages 17 & 18 for the list of flash patterns, showing the cause & recommended course of action for each of the conditions which may be detected.

NOTICE

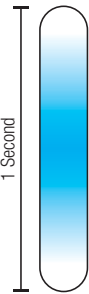
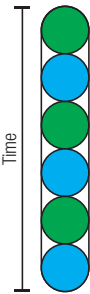
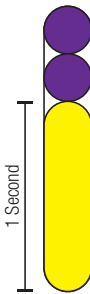
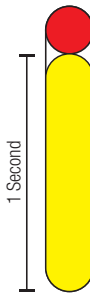
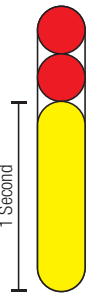
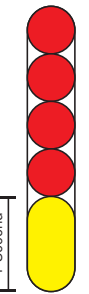
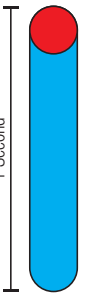
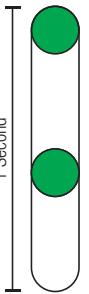
**Even intermittent faults are detected and may be indicated until cleared.
Most fault codes can be cleared by unplugging the trailer for 1 minute then reconnecting.**

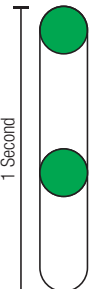
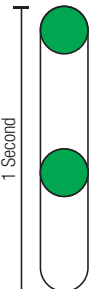
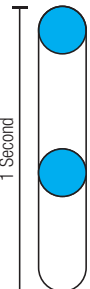
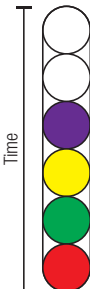
LED Sequence	Symptom/Description	Possible Cause	Suggested Action
	BLUE Breathing when the Override button is pushed	The trailer brakes have not been detected	Check the trailer plug and all connections to the brake controller.
	Flashing a Blue/ Green sequence.	The unit is in the process of calibrating, this is NOT a fault.	Keep driving normally and the unit will calibrate
	The LED is YELLOW and flashes PURPLE twice	There is a fault with the unit and/or the installation.	Check and clean trailer plug connection. Please contact REDARC or visit your local auto-electrician for further assistance
	The LED is YELLOW and flashes RED once	There is a short circuit somewhere on the brake output line (BLUE wire)	Check all wiring from the unit to the trailer brakes for any wiring faults, including at trailer plug
	The LED is YELLOW and flashes RED twice	There is a short circuit somewhere on the brake light circuit (RED wire)	Check all wiring from the unit to the brake light trigger for any wiring faults
	The LED is YELLOW and flashes RED four times	There is a break/open circuit somewhere along the Tow-Pro™ Elite's Ground circuit (WHITE wire)	Check all ground connections and associated wiring for any wiring faults
	The LED is BLUE and flashes RED once a second	The unit has detected that the Remote Cable is faulty	Check the Remote cable is fully plugged in, otherwise replace
	The LED is flashing GREEN only whilst braking	Loss of supply power or Circuit Breaker cycling	Check supply (BLACK) wire for connection problems and check circuit breaker/fuse is not blown and is the correct value

LED Sequence	Symptom/Description	Possible Cause	Suggested Action
	<p>The LED is flashing GREEN at any time</p>	<p>Hesitation during connection of BLACK wire possibly causing incomplete startup sequence</p>	<p>Disconnect BLACK wire, wait 1 minute and reconnect BLACK wire to the battery</p>
	<p>The LED is flashing GREEN at any time or only when not braking</p>	<p>Low continuous voltage on brake light (RED) wire</p>	<p>Check that RED wire is connected to a point that is 0V when the brakes are off and 12V with the brakes applied</p>
	<p>The LED is flashing BLUE</p>	<p>The power supply to the unit is not stable.</p>	<p>Check the BLACK and WHITE wires for loose connections</p>
	<p>The LED flashes an unusual colour sequence randomly whilst braking</p>	<p>There is a short circuit on the output (BLUE) wire or the Fuse or Circuit Breaker is overloaded</p>	<p>Check for short circuit on brake light (RED) circuit Check for short circuit on trailer brake (BLUE) circuit, including moving brake swing arms Check that no other devices are running from the same Fuse or Circuit Breaker as the Tow-Pro Elite</p>
	<p>LED only lights up when braking and brake light fuse may have blown</p>	<p>The power wire is most likely not connected</p>	<p>Check supply (BLACK) wire for connection problems and check circuit breaker/fuse is not blown</p>
	<p>The LED is not working at all</p>	<p>There is a bad connection to the trailer</p>	<p>Check the trailer wiring as the unit is not recognising that a trailer is connected.</p>

⚠ WARNING

Ensure that your trailer brakes are installed and are operating correctly: Improperly installed and/or faulty trailer brakes can cause erratic vehicle or trailer behaviour with the potential to cause a road accident. For this reason, it is of utmost importance that your trailer braking system be installed/maintained by a qualified installer. Always check brakes at low speed each time a trailer is attached to your vehicle.

Immediately After Installation (To be done by a qualified Auto-Electrician)

Test the installation/vehicle wiring. Testing your vehicle wiring is best done by connecting a test light (Max 21W filament globe) to the brake output, pushing the manual override and having someone check that the vehicle brake lights and the test lamp both light up.

Before each trip

It is important to ensure that your system is operating correctly before you set out. The following should be checked, along with standard mechanical maintenance, each time you attach your trailer:

- Correct brake light operation on both your vehicle and trailer
- Correct operation and setting of the electric brake controller
- Correct operation of your trailer brakes
- Check that your breakaway system is operating correctly and that the breakaway battery is healthy (if applicable)
- Ensure that the tow hitch, and safety chains and weight distribution systems are setup correctly

Periodically

It is important to have a qualified technician check the function of your trailer system on a periodic basis to ensure that everything is operating correctly. REDARC recommend that you visit a qualified technician before the beginning of each holiday season to ensure that any towing aids or systems are working correctly.

Other considerations

Please consider the below items whilst towing a trailer:

- Ensure that your vehicle is capable of towing the trailer
- Ensure that you adjust your driving style to allow more time to change lanes and brake
- Always remember that your electric brake controller is designed to supplement your vehicle brakes; *do NOT use the Tow-Pro™ Elite manual override in place of your vehicle foot brake*
- REDARC recommend professional towing training before attempting to tow a trailer; companies such as Tow-Ed offer these services

The LED is flashing Blue/Green, what does this mean?

A Blue/Green flash sequence indicates that the unit is in the process of calibration, as the unit becomes more confident in its calibration the Blue will appear for longer. Keep driving and eventually this will turn to a solid Blue.

Is the Tow-Pro™ Elite approved to use with the my Electronic Trailer Stability Control system?

The Tow-Pro™ Elite is approved for use with the AL-KO ESC and the Dexter Sway Control systems. Please visit the manufacturer's website for more information.

How do I change from Proportional to User Controlled mode?

Please see section 3.3.3 of this manual.

Will it work with electric over hydraulic trailer brakes?

Yes, please see section 3.5 of this manual.

Can it be mounted in any orientation? How do I set the levelling of the main unit?

Yes, the unit can be installed inside the vehicle at any angle, provided it is firmly secured and in a location which allows access to the intended remote head location. Please see sections 2.1, 2.3 and 2.4 of this manual for more information.

My vehicle has shared tail/brake lights, will the Tow-Pro™ Elite work OK?

Yes, the Tow-Pro™ Elite is designed to operate correctly from both standard and shared tail/brake lights.

My caravan is 3.5 tonnes fully loaded; Is the Tow-Pro™ Elite strong enough to stop that much weight safely?

The controller is capable of supplying 3-axle setups at 12V or 24V inputs up to the maximum rated braking ability of the brakes. You must also ensure that your trailer brakes are adequate for the trailer load.

Can the remote head cable be extended?

Yes, the remote head cable is a standard RJ45 network cable and can be replaced by an off the shelf cable up to 5m in length. If the cable used is longer than 1m however we recommend using a ferrite bead, such as Jaycar P/N LF1294, clipped onto the cable as close as possible to the main unit.

Can the braking level of the manual over-ride be adjusted?

Yes, the manual override can be adjusted whilst it is being applied by turning the gain control knob. For more information on manual override please see section 3.2 of this manual.

Will my trailer brakes work while I am reversing?

The Tow-Pro™ Elite is designed to apply the trailer brakes whether the vehicle is travelling forward or in reverse. The effectiveness of the brake application in reverse will depend on the mechanical design of your particular electric brake system.

I have a 2 axle trailer, is the Tow-Pro™ Elite suitable for my trailer?

Yes, the Tow-Pro™ Elite is designed to operate up to 3-axle trailers.

I lost the knob/nut/bezel, where can I get one?

The knob, nut or bezel can be purchased as spare parts from REDARC authorised resellers.

7 TWO YEAR PRODUCT WARRANTY

Over the last three decades our company has established a reputation as the power conversion specialist.

A 100% Australian-owned company, we have met the needs of customers in transport and other industries through exciting, innovative thinking.

We believe in total customer satisfaction and practice this by offering our customers:

- Technical advice free of jargon and free of charge
- Prompt turnaround of orders throughout Australia and globally
- Friendly, personalised, professional service and product support

In the unlikely event that a technical issue arises with a Redarc product, customers are encouraged to initially contact the Redarc Technical Support Team on (08) 8322 4848 or power@redarc.com.au for prompt and efficient diagnosis and product support.

Our goods come with guarantees that cannot be excluded under the Australian Consumer Law. You are entitled to a replacement or refund for a major failure and compensation for any other reasonably foreseeable loss or damage. You are also entitled to have the goods repaired or replaced if the goods fail to be of acceptable quality and the failure does not amount to a major failure.

The benefits of this Warranty are in addition to other rights and remedies available at law in respect of the Products and shall not derogate from any applicable mandatory statutory provisions or rights under the Australian Consumer Law.

Redarc Electronics Pty Ltd at the Redarc Trust trading as Redarc Electronics ("**Redarc**") offers a warranty in respect of its Products where the Products are purchased from an authorised distributor or reseller of Redarc by a person ("**Purchaser**"), on the terms and conditions, and for the duration, outlined below in this document ("**Warranty**").

1. In this Warranty, the term **Products** means:
 - 1.1 all products manufactured or supplied by Redarc (excluding its solar products which are covered by Redarc's Solar Product Warranty); and
 - 1.2 any component of or accessory for any product in clause 1.1 manufactured or supplied by Redarc.

Offer and duration of product warranties

2. Redarc warrants that its Products will be free, under normal application, installation, use and service conditions, from defects in materials and workmanship affecting normal use, for **2 years** from the date of purchase (**Warranty Period**).
3. Where a Product malfunctions or becomes inoperative during the Warranty Period, due to a defect in materials or workmanship, as determined by Redarc, then subject to further rights conferred by the Australian Consumer Law on the Purchaser, Redarc will, in exercise of its sole discretion, either:
 - 3.1 repair the defective Product;
 - 3.2 replace the defective Product; or
 - 3.3 provide a refund to the Purchaser for the purchase price paid for the defective Product,without charge to the Purchaser.
4. The warranty given by Redarc in clause 3 covers the reasonable costs of delivery and installation of any repaired or replaced Products or components of Products to the Purchaser's usual residential address notified to Redarc, together with the reasonable costs of removal and return of any Products determined by Redarc to be defective.
5. If the Purchaser incurs expenses of the nature referred to in clause 4 in the context of making a claim pursuant to this Warranty that is accepted by Redarc, the Purchaser will be entitled to claim for reimbursement of those expenses which Redarc determines, in exercise of its sole discretion, to be reasonably incurred, provided that the claim is notified to Redarc in writing at the postal address or email address specified in clause 21 and includes:
 - 5.1 details of the relevant expenses incurred by the Purchaser; and
 - 5.2 proof of the relevant expenses having been incurred by the Purchaser.

Exclusions and limitations

6. This Warranty will not apply to, or include any defect, damage, fault, failure or malfunction of a Product, which Redarc determines, in exercise of its sole discretion, to be due to:
 - 6.1 normal wear and tear or exposure to weather conditions over time;
 - 6.2 accident, misuse, abuse, negligence, vandalism, alteration or modification;
 - 6.3 non-observance of any of the instructions supplied by Redarc, including instructions concerning installation, configuring, connecting, commissioning, use or application of the Product, including without limitation choice of location;
 - 6.4 failure to ensure proper maintenance of the Product strictly in accordance with Redarc's instructions or failure to ensure proper maintenance of any associated equipment or machinery;
 - 6.5 repairs to the Product that are not strictly in accordance with Redarc's instructions;
 - 6.6 installation, repairs or maintenance of the Product by, or under the supervision of, a person who is not a qualified auto electrician or technician, or if non-genuine or non-approved parts have been fitted;
 - 6.7 faulty power supply, power failure, electrical spikes or surges, lightning, flood, storm, hail, extreme heat, fire or other occurrence outside the control of Redarc;
 - 6.8 use other than for any reasonable purpose for which the Product was manufactured;
 - 6.9 any indirect or incidental damage of whatever nature outside the control of Redarc.
7. Warranty claims in respect of a Product must be made in writing to Redarc at the postal address or email address specified in clause 21 within the Warranty Period. Such claims must include the following:
 - 7.1 details of the alleged defect or fault and the circumstances surrounding the defect or fault;
 - 7.2 evidence of the claim, including photographs of the Product (where the subject of the claim is capable of being photographed);
 - 7.3 the serial number of the Product, specified on the label affixed to the Product; and
 - 7.4 proof of purchase documentation for the Product from an authorised distributor or reseller of Redarc, which clearly shows the date and place of purchase.The return of any Products without the prior written instructions of Redarc will not be accepted by Redarc.

8. Without limiting any other clause in this Warranty, Redarc has the right to reject any Warranty claim made by a Purchaser pursuant to this Warranty where:
 - 8.1 the Purchaser does not notify Redarc in writing of a Warranty claim within the Warranty Period;
 - 8.2 the Purchaser does not notify Redarc in writing of a Warranty claim within 1 month of becoming aware of the relevant circumstances giving rise to the claim, so that any further problems with the Product are minimised;
 - 8.3 the serial number of the Product has been altered, removed or made illegible without the written authority of Redarc;
 - 8.4 the Purchaser is unable to provide proof of purchase documentation in accordance with clause 7.4 or evidence that the Product was properly installed and removed (if relevant), and that proper maintenance has been performed on the Product, by, or under the supervision of, a qualified auto electrician or technician, in accordance with the instructions of Redarc.
9. If the Product is found to be working satisfactorily on return to Redarc or upon investigation by Redarc, the Purchaser must pay Redarc's reasonable costs of testing and investigating the Product in addition to shipping and transportation charges. Where Redarc is in possession of the Product, the Product will be returned to the Purchaser on receipt of the amount charged.
10. Any replaced Products or components of Products shall become the property of Redarc.
11. Redarc may, in exercise of its sole discretion, deliver another type of Product or component of a Product (different in size, colour, shape, weight, brand and/or other specifications) in fulfilling its obligations under this Warranty, in the event that Redarc has discontinued manufacturing or supplying the relevant Product or component at the time of the Warranty claim, or where such Product or component is superior to that originally purchased by the Purchaser.

Other conditions of Warranty

12. If the Purchaser acquired a Product for the purpose of resupply, then this Warranty shall not apply to that Product.
13. In particular, the sale of a Product via an online auction, online store or other internet website by a party that is not an authorised distributor or reseller of the Product will be deemed to be a resupply within the meaning of the Australian Consumer Law and will render this Warranty void, as Redarc has no control over the storage, handling, quality or safety of Products sold by such persons.
14. A Purchaser shall only be entitled to the benefit of this Warranty after all amounts owing in respect of the Product have been paid.
15. While Redarc warrants that the Products will be free from defects in materials and workmanship in the circumstances set out in this Warranty, to the maximum extent permitted by law Redarc does not warrant that the operation of the Products will be uninterrupted or error-free.
16. To the maximum extent permitted by law, Redarc's determination of the existence of any defect and the cause of any defect will be conclusive.
17. Spare parts or materials for the Products are guaranteed to be available for a period of at least 2 years after purchase of the Products.
18. The agents, officers and employees of any distributor or reseller of the Products and of Redarc are not authorised to vary or extend the terms of this Warranty.
19. Redarc shall not be responsible or liable to the Customer or any third party in connection with any non-performance or delay in performance of any terms and conditions of this Warranty, due to acts of God, war, riots, strikes, warlike conditions, plague or other epidemic, fire, flood, blizzard, hurricane, changes of public policies, terrorism and other events which are beyond the control of Redarc. In such circumstances, Redarc may suspend performance of this Warranty without liability for the period of the delay reasonably attributable to such causes.
20. If a clause or part of a clause in this Warranty can be read in a way that makes it illegal, unenforceable or invalid, but can also be read in a way that makes it legal, enforceable and valid, it must be read in the latter way. If any clause or part of a clause in this Warranty is illegal, unenforceable or invalid, that clause or part is to be treated as removed from this Warranty, but the rest of this Warranty is not affected.

Redarc's contact details

21. Redarc's contact details for the sending of Warranty claims under this Warranty are:
REDARC Electronics Pty Ltd
23 Brodie Road (North), Lonsdale SA 5160
Email: power@redarc.com.au
Telephone: +61 8 8322 4848

*Some Dexter systems may require a load resistor

Free technical assistance!

For product and technical support contact your regional distributor, call our head office between 8:00am to 5:30pm Australian Central Standard Time, Monday to Friday or send an email using the regional specific details outlined below.



Australia (and other Global regions)

power@redarc.com.au

www.redarc.com.au

+61 8 8322 4848

New Zealand

power@redarcelectronics.co.nz

www.redarcelectronics.co.nz

+64-9-222-1024

North America

power@redarcelectronics.com

www.redarcelectronics.com

United States

+1 (704) 247-5150

Canada

+1 (604) 260-5512

Mexico

+52 (558) 526-2898

UK/Europe

power@redarcelectronics.eu

www.redarcelectronics.eu

+44 (0)20 3930 8109

Australian Registered Design 352577

Australian Registered Design 352578

Australian Registered Design 352674

Australian Registered Patent 2014224076

Australian Registered Innovation Patent 2017100513

**For specific USA
Warranty terms
please visit...**

www.redarcelectronics.com

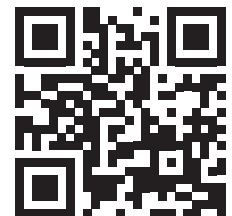

Copyright © 2018 REDARC Electronics Pty Ltd. All rights reserved.