

# Gemstones

Quilt Design by Cyndi Hershey

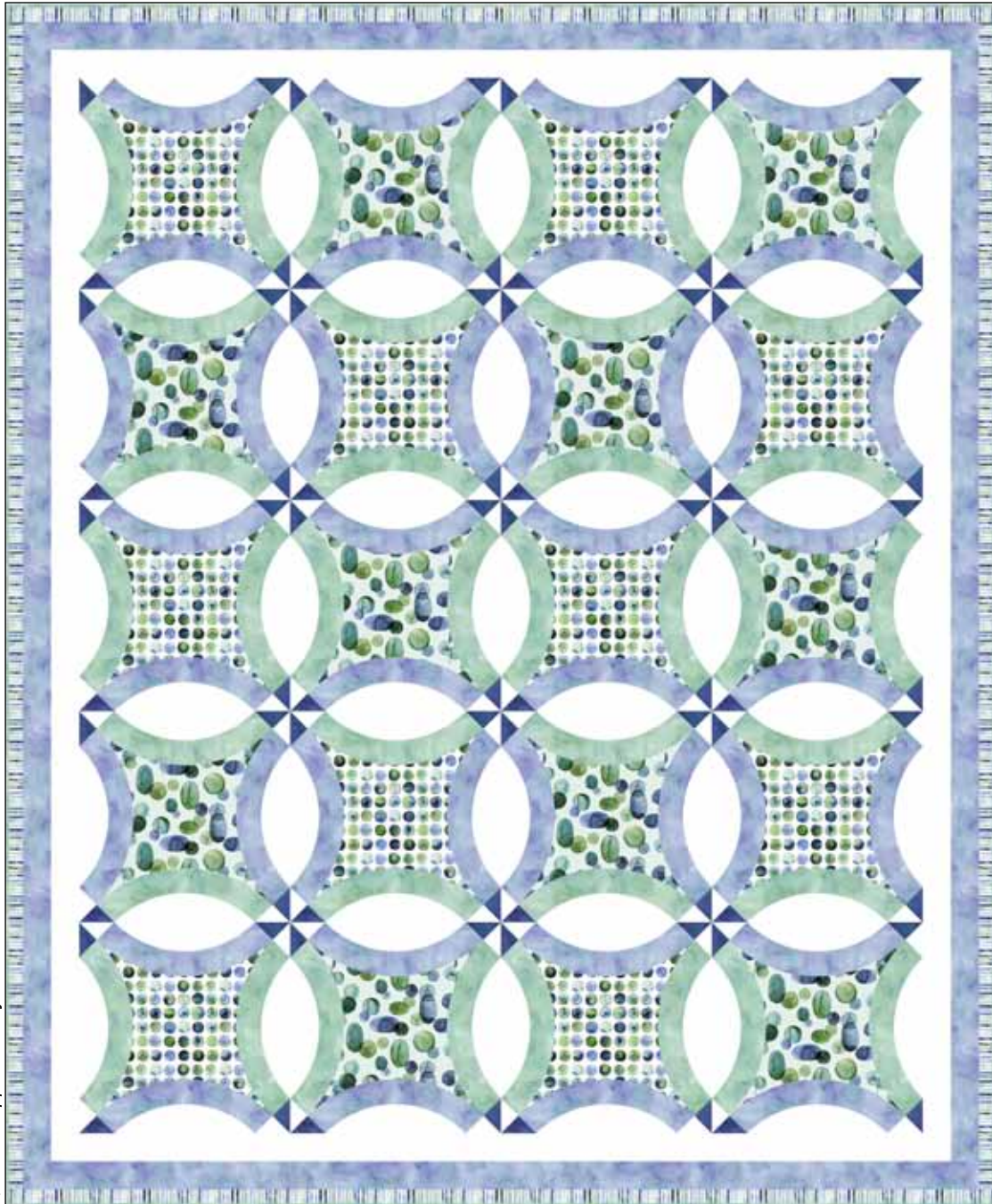

Quilt size: approximately 70" x 85"



Featuring fabrics from  
*Gemstones* by Stephanie Ryan

P&B Textiles • pbtex.com • 800-351-9087 • 208 Clock Tower Square, Portsmouth, RI 02871

# Gemstones

Fabric collection by Stephanie Ryan

Quilt designed by Cyndi Hershey

Skill level: Intermediate Plus • Finished Quilt Size: approximately 70" x 85"

## Quilt Yardages:

Fabric A:	<b>GEMS 5220 BG</b>	.....	1 5/8 yards
Fabric B:	<b>GEMS 5223 BG</b>	.....	1 5/8 yards
Fabric C:	<b>GEMS 5225 BG</b>	.....	1/2 yard
Fabric D:	<b>CSTO 5226 DB</b>	.....	3/8 yard
Fabric E:	<b>CSTO 5226 LB</b>	.....	3 yards
Fabric F:	<b>CSTO 5226 LT</b>	.....	3 yards
Fabric G:	<b>RA13 4883 W</b>	.....	3 1/8 yards
Backing:	<b>GEMS 5222 BG suggested</b>	.....	5 1/4 yards
Batting		.....	78" x 93"

Additional supplies: template plastic, freezer paper or other material to make templates.

## Cutting Instructions:

All strips are cut across the width of the fabric (perpendicular to selvages) unless noted otherwise. All seams are 1/4". Prepare templates using the masters that are provided.

**Note:** This is a Double Wedding Ring quilt but has an easier method of construction. This quilt is created using 15" finished square blocks to make assembly easier.

**Note:** You may find it helpful to make one "test" unit before you begin on the quilt blocks. Doing so can help give you understanding of the construction process.

### From Fabric A:

1. Cut ten block centers using Template 1. (Blocks)

### From Fabric B:

1. Cut ten block centers using Template 1. (Blocks)

### From Fabric C:

1. Cut eight 1 1/2" strips. Sew strips together end to end with diagonal seams. Trim seams and press open. From this pieced strip, cut two 1 1/2" x 70 1/2" strips and two 1 1/2" x 83 1/2" strips. (Outer Border)

### From Fabric D:

1. Cut two 3 3/4" strips; subcut twenty 3 3/4" squares. Cut each square diagonally in both directions to yield eighty quarter-square triangles. (Blocks)

### From Fabric E:

1. Cut five 14" strips. Cut forty arcs using Template 2. You should be able to cut eight shapes per strip. (Blocks)
2. Cut eight 2 1/2" strips. Sew strips together end to end with diagonal seams. Trim seams and press open. From this pieced strip, cut two 2 1/2" x 68 1/2" strips and two 2 1/2" x 79 1/2" strips. (2nd Border)

### From Fabric F:

1. Cut five 14" strips. Cut forty arcs using Template 2. You should be able to cut eight shapes per strip. (Blocks)
2. Cut nine 2 1/2" strips. (Binding)

### From Fabric G:

1. Cut seven 11" strips. Cut eighty shapes (half-melons) using Template 3. You should be able to cut thirteen shapes per strip. (Blocks)
2. Cut two 3 3/4" strips; subcut twenty 3 3/4" squares. Cut each square diagonally in both directions to yield eighty quarter-square triangles. (Blocks)
3. Cut eight 2 1/2" strips. Sew strips together end to end with diagonal seams. Trim seams and press open. From this pieced strip, cut two 2 1/2" x 64 1/2" strips and two 2 1/2" x 75 1/2" strips. (Inner Border)

## Piecing Instructions:

1. Sew one Template 3/G half-melon to one Template 2/E arc. Begin by matching the centers of both shapes and pinning, taking a tiny "bite" of fabric. Then, match the seam points at both ends of the two shapes and pin. Sew seam. Some sewers prefer a slightly shorter stitch to help maneuver the curve. Press toward G.
2. Sew one D triangle to the right end of the Step 1 unit. Press open. Sew one G triangle to the left end of the unit. Press open. Repeat to make forty units. (Figure 1)



Figure 1 Make 40.

3. Repeat Steps 1 and 2 using Template 2/F arcs with Template 3/G half-melons. (Figure 2)



Figure 2 Make 40.

4. Sew one E/G unit to both sides of one Template 1/A block center, matching seam points. Press toward the E/G unit. Sew one F/G unit to the remaining two sides of the center; press. Repeat to make ten blocks. (Figure 3)



Figure 3 Make 10.  
15 1/2" square unfinished.

5. Repeat Step 4 using Template 1/B block centers. (Figure 4)

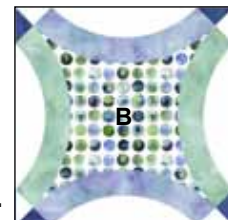
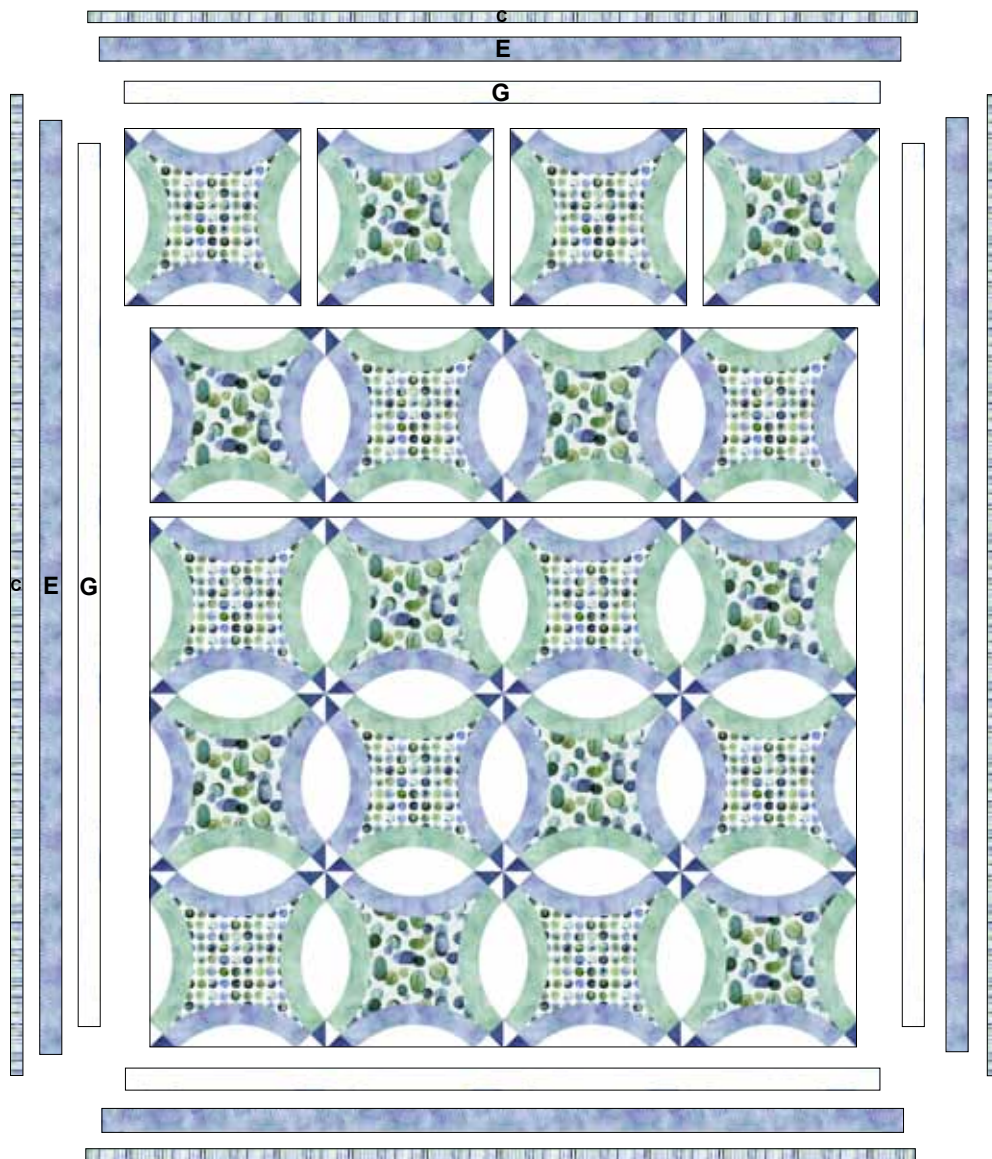

Figure 4 Make 10.  
15 1/2" square unfinished.

6. Refer to Quilt Diagram to lay blocks into rows alternating the two blocks. Be sure to rotate blocks so that the E and F arcs connect visually to create "rings". Sew blocks into rows and press seams open.
7. Sew rows together and press seams open.
8. Sew one 2 1/2" x 75 1/2" G strip to both sides of Quilt Center. Press toward G. Sew one 2 1/2" x 64 1/2" G strip to the top and bottom of the Quilt Center; press.
9. Sew one 2 1/2" x 79 1/2" E strip to both sides of the quilt. Press toward F. Sew one 2 1/2" x 68 1/2" E strip to the top and bottom of the quilt; press.
10. Sew one 1 1/2" x 83 1/2" C strip to both sides of the quilt. Press toward C. Sew one 1 1/2" x 70 1/2" C strip to the top and bottom of the quilt; press.

### *Finishing:*

1. Prepare backing using two widths. Press seams open and trim to 78" x 93".
2. Layer quilt, batting, and backing. Baste layers together.
3. Quilt as desired.
4. Trim layers even with quilt top, squaring corners.
5. Join nine 2 1/2" F binding strips with diagonal seams. Press seams open. Attach binding using your favorite method.
6. Make a label and sew to the back of the quilt.



*Quilt Diagram*

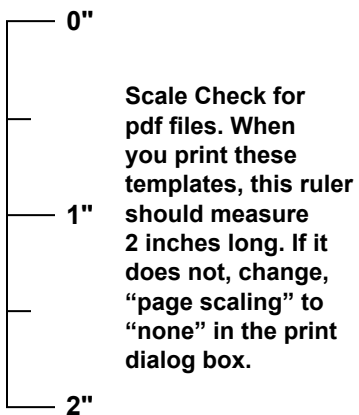
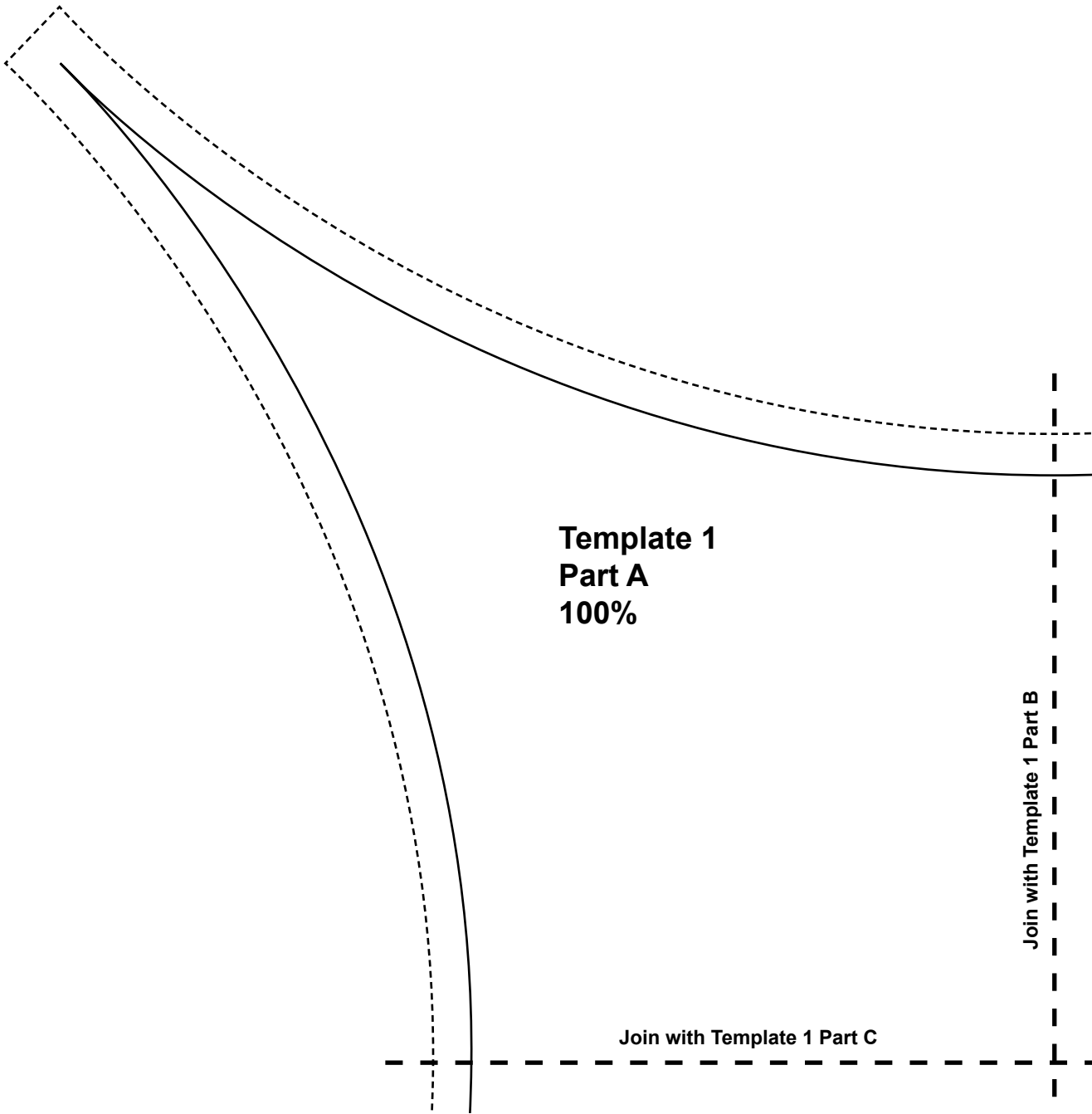

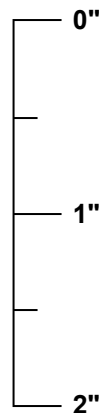
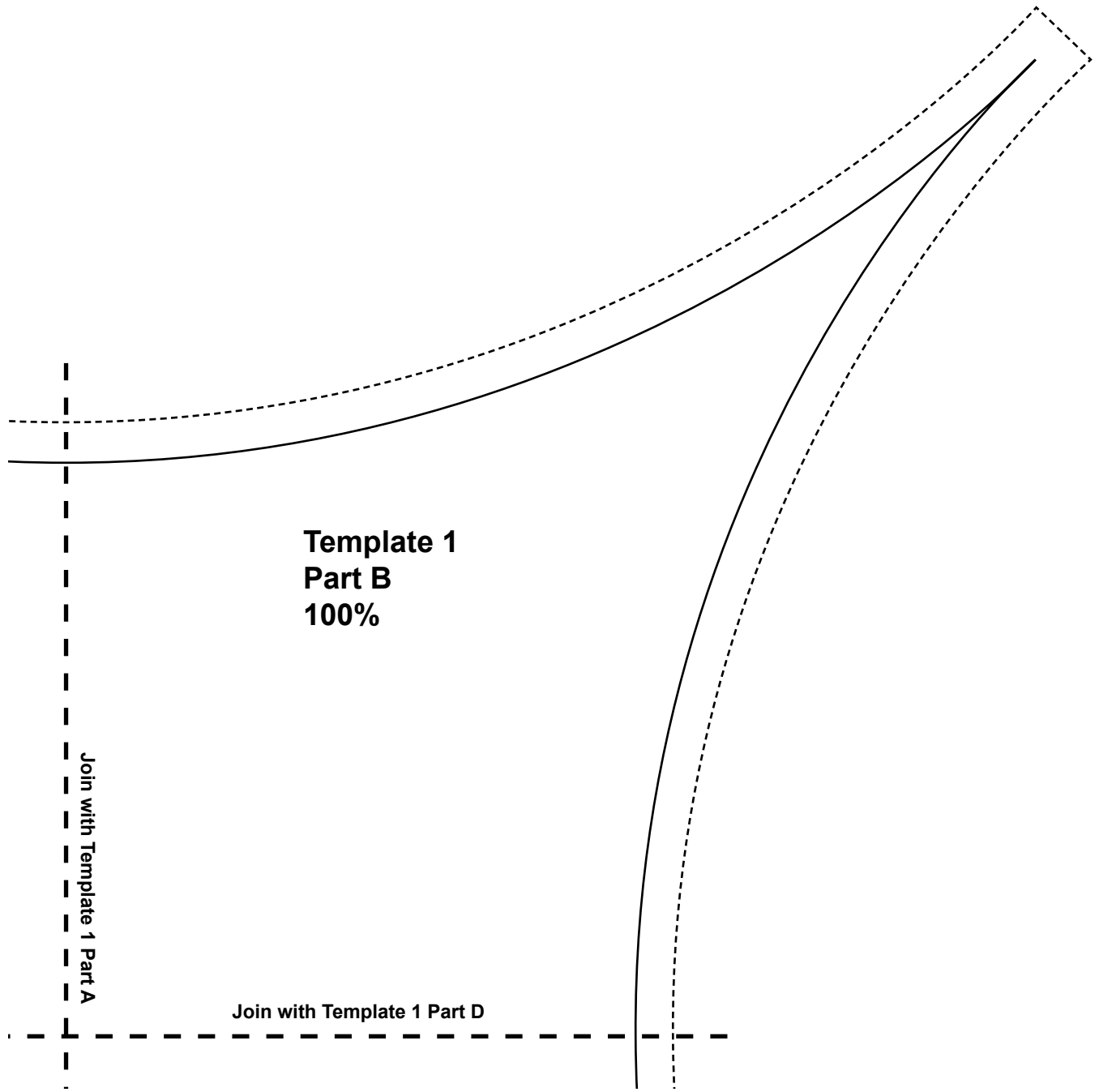

**Scale Check for pdf files. When you print these templates, this ruler should measure 2 inches long. If it does not, change, "page scaling" to "none" in the print dialog box.**

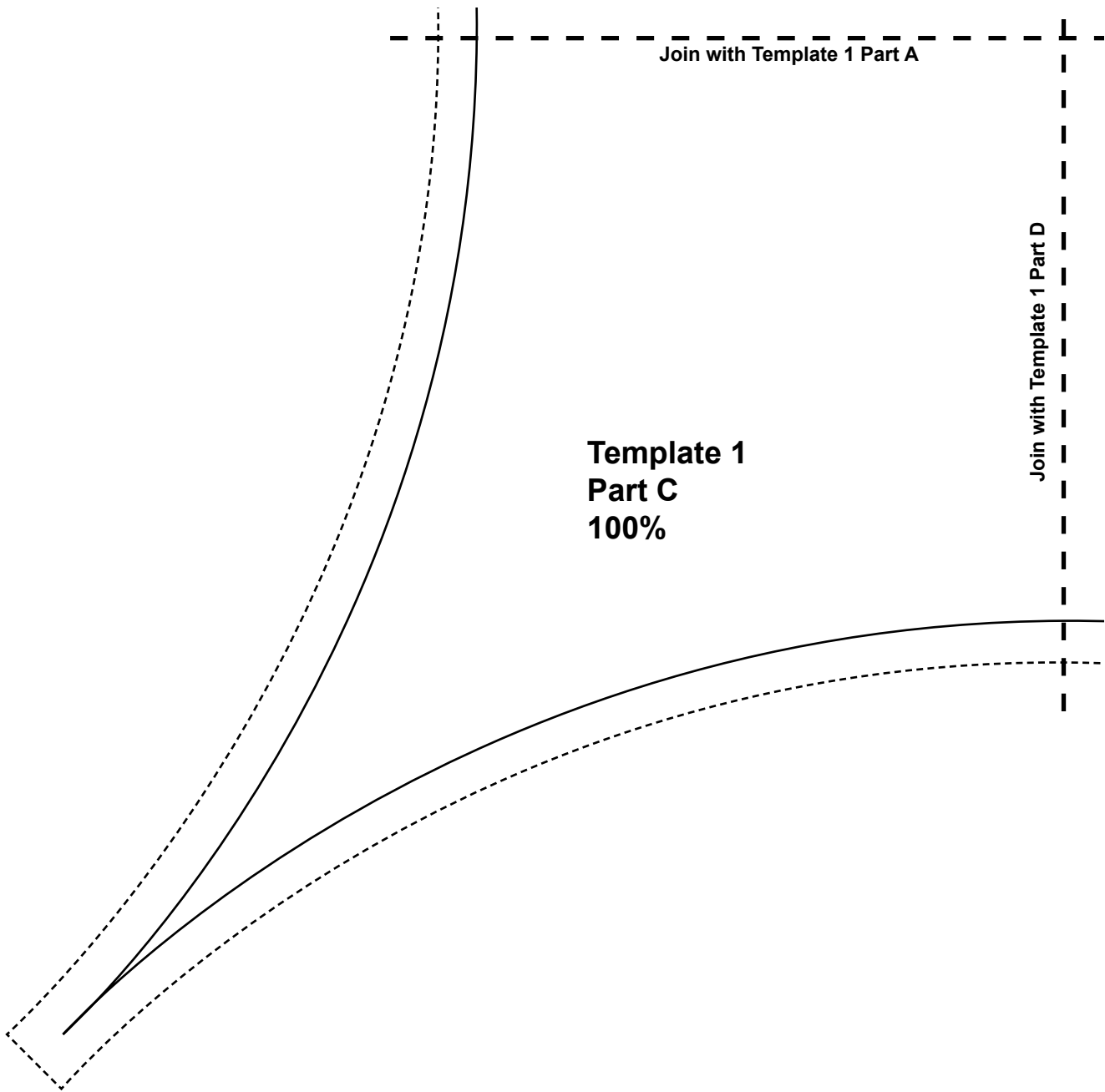

**Template 1  
Part C  
100%**

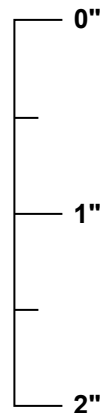

**Scale Check for pdf files. When you print these templates, this ruler should measure 2 inches long. If it does not, change, "page scaling" to "none" in the print dialog box.**

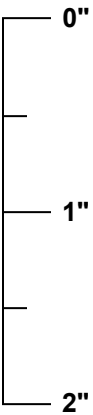
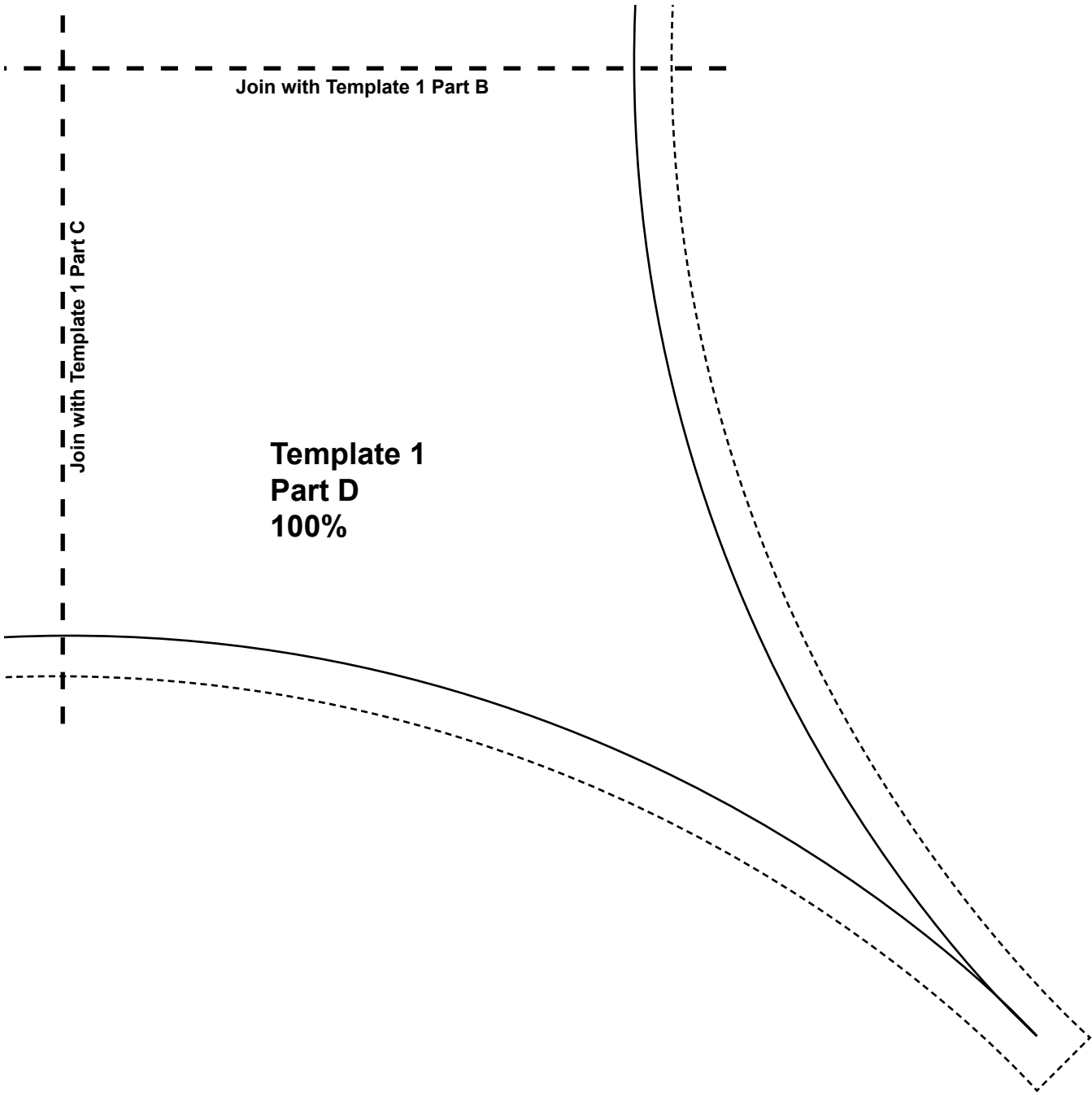

**Scale Check for pdf files. When you print these templates, this ruler should measure 2 inches long. If it does not, change, "page scaling" to "none" in the print dialog box.**

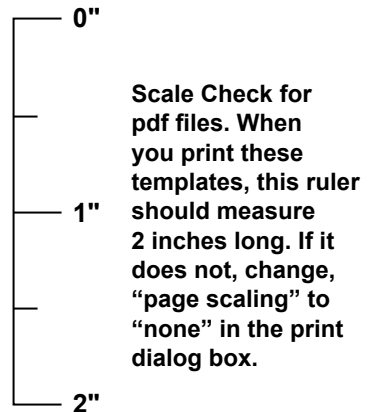
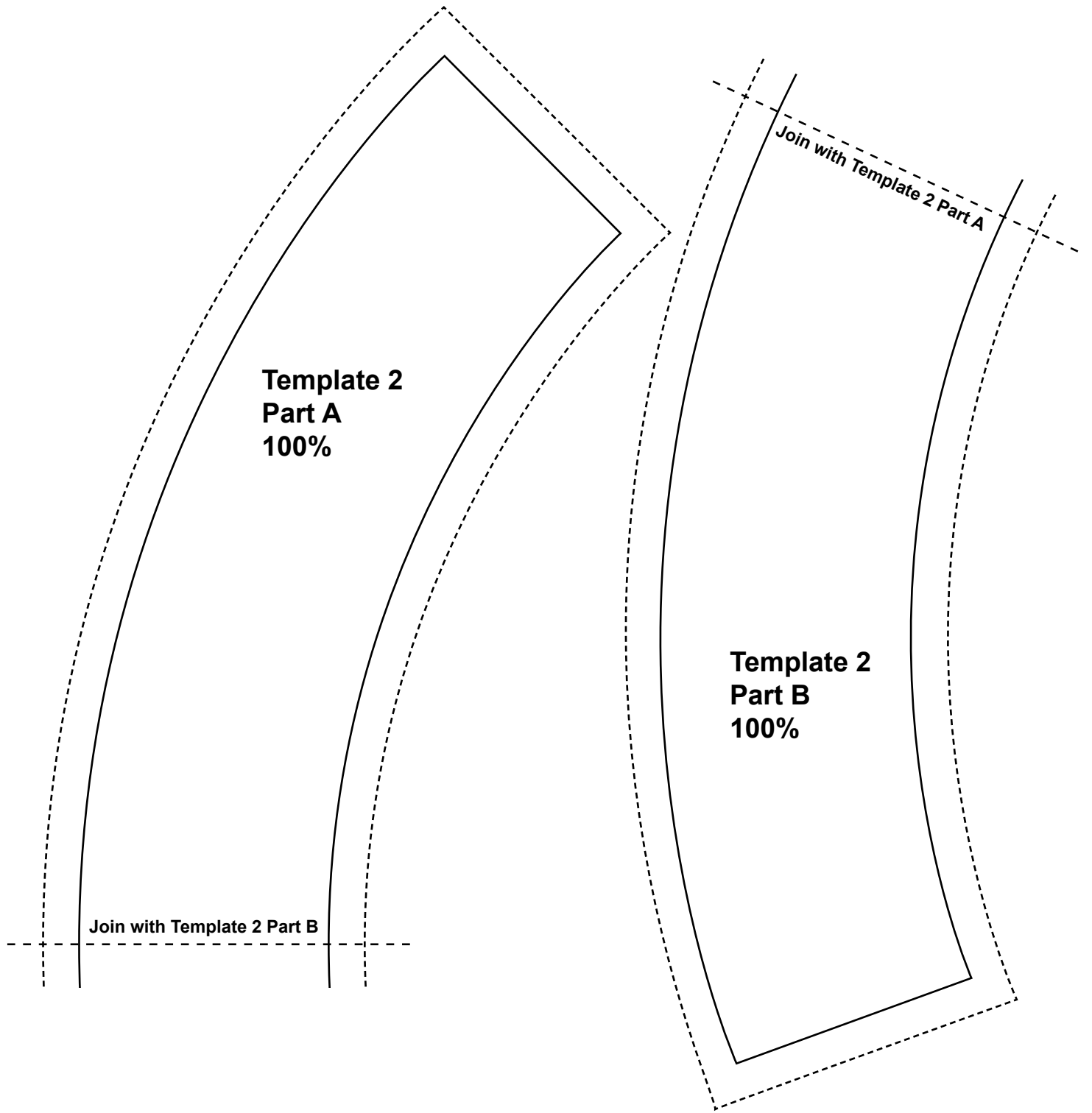



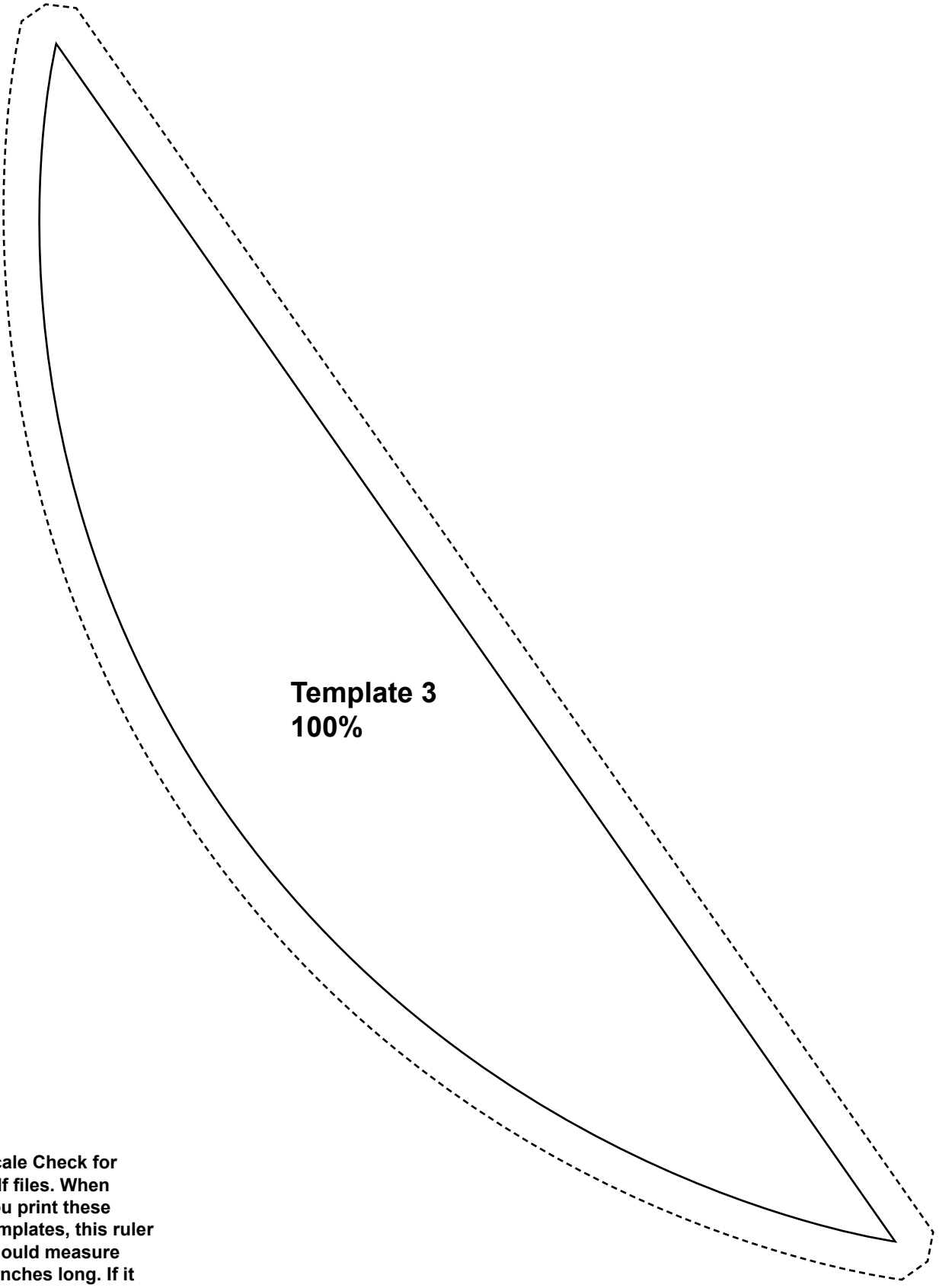

**Template 3  
100%**

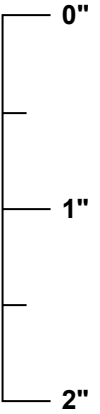

**Scale Check for pdf files. When you print these templates, this ruler should measure 2 inches long. If it does not, change, "page scaling" to "none" in the print dialog box.**

# Gemstones

Fabric Collection by Stephanie Ryan



GEMS 5219 BG



GEMS 5219 MU



GEMS 5220 BG\*



GEMS 5220 MU



GEMS 5221 BG



GEMS 5221 MU

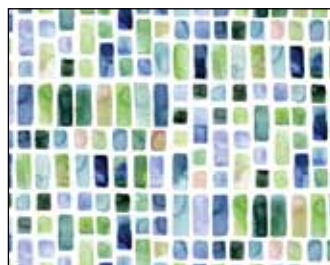

GEMS 5222 BG†



GEMS 5222 MU

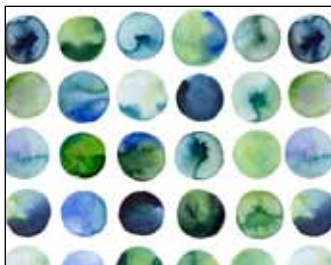

GEMS 5223 BG\*



GEMS 5223 MU



GEMS 5224 BG



GEMS 5224 MU

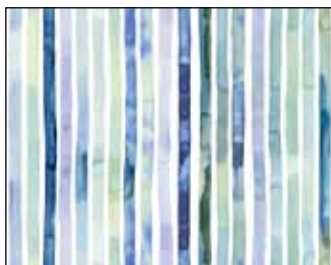

GEMS 5225 BG\*

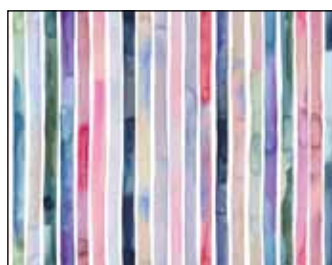

GEMS 5225 MU



CTSO 5226 DB\*



CTSO 5226 LB\*



CTSO 5226 LT\*

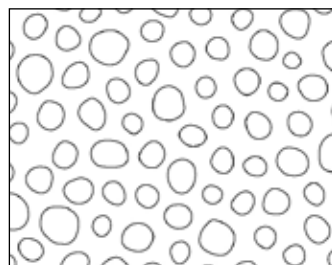

RA13 4883 W\*



P&B Textiles • pbtex.com • 800-351-9087 • 208 Clock Tower Square, Portsmouth, RI 02871

\*Fabrics used in quilt.

†Backing