

— Instruction Manual —

BNP0401BC / BNP0701B

BNP1501B / BNP2101B

4' / 7 1/2' / 15' & 21' Portable Player Bench

Aluminum or Powdercoated Steel Frame Assembly



Customer Service
(800) 247-7668

PARTS LIST									
Item	4' or 7 1/2' Qty	15' Qty	21' Qty	Description	Item	4' or 7 1/2' Qty	15' Qty	21' Qty	Description
A	2	2	2	Aluminum Seat	G	12	18	24	3/8" Lock Washer
B	2	3	4	Leg Assembly	H	8	12	16	Plastic Tube Plug
C	8	12	16	3/8-16 x 3" Carriage Bolt	I	4	6	8	Rubber Feet
D	4	6	8	3/8-16 x 1 1/2" Hex Bolt	J	4	4	4	Seat End Cap
E	8	12	16	Bench Clamp	K	8	8	8	#10 X 3/4" Sheet Metal Screw
F	12	18	24	3/8" Hex Nut	L	4	6	8	3/8" Flat Washer

- ◆ Inspect all contents prior to installation. Report any missing parts to dealer immediately.
- ◆ Read all instructions before proceeding.

If Your Bench Is 4' or 7 1/2' In Length

1. Attach the *Leg Assemblies* (B) to the 4' or 7 1/2' *Aluminum Seats* (A) with 3/8" x 3" *Carriage Bolts* (C), 3/8" *Lock Washers* (G), 3/8" *Hex Nuts* (F) and *Bench Clamps* (E). See Figure 1.
2. Insert *Plastic Tube Plugs* (H) in *Leg Assemblies* (B). See Figure 1.
3. If you want the bench to be portable attach the *Rubber Feet* (I) to the *Leg Assemblies* (B) with 3/8" x 1 1/2" *Hex Bolts* (D), 3/8" *Flat Washers* (L), 3/8" *Lock Washers* (G) and 3/8" *Hex Nuts* (F). See Figure 6.
4. The *Leg Assemblies* (B) should be placed 8" from each end. See Figure 3.
5. Install *Seat End Caps* (J) using #10 x 3/4" *Sheet Metal Screws* (K). See Figure 2.
6. If you want the bench to be fixed anchor each *Leg Assembly* (B) in 2 places using the appropriate anchors (not included) for the mounting surface. See Figure 7.

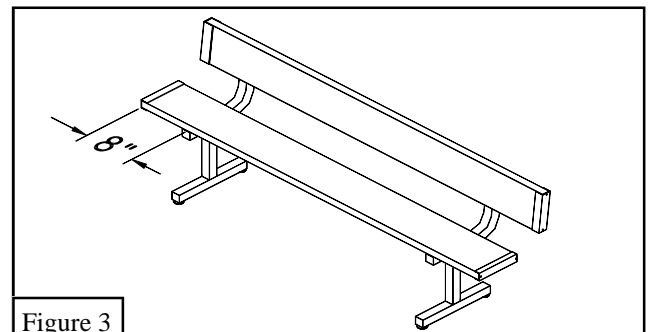
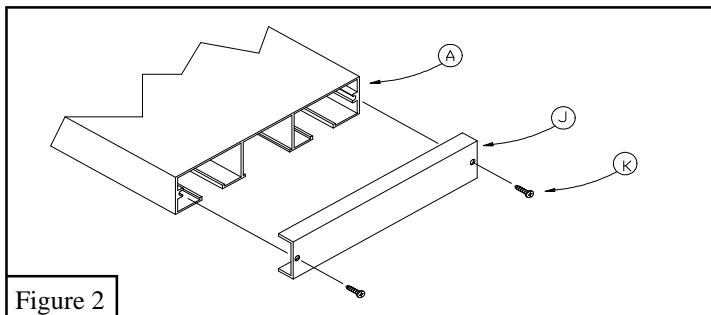
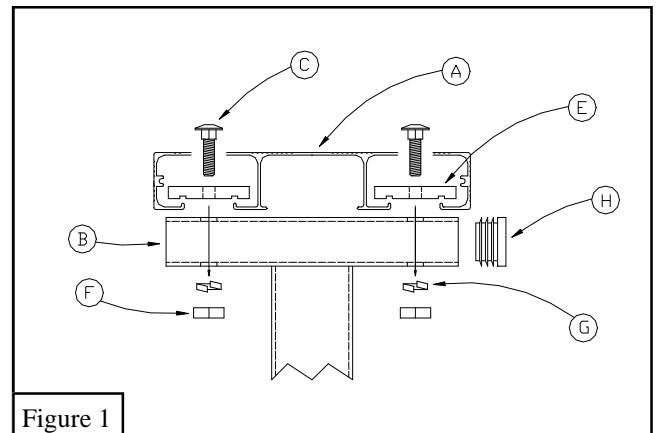

If Your Bench Is 15' In Length

1. Attach the *Leg Assemblies (B)* to the *15' Aluminum Seats (A)* with *3/8" x 3" Carriage Bolts (C)*, *3/8" Lock Washers (G)*, *3/8" Hex Nuts (F)* and *Bench Clamps (E)*. See Figure 1.
2. Place the first *Leg Assembly (B)* in the center of the *15' Aluminum Seats (A)*. The remaining *Leg Assemblies (B)* should be placed 18" from each end. See Figure 4.
3. If you want the bench to be portable attach the *Rubber Feet (I)* to the *Leg Assemblies (B)* with *3/8" x 1 1/2" Hex Bolts (D)*, *3/8" Flat Washers (L)*, *3/8" Lock Washers (G)* and *3/8" Hex Nuts (F)*. See Figure 6.
4. If you want the bench to be fixed anchor each *Leg Assembly (B)* in 2 places using the appropriate anchors (not included) for the mounting surface. See Figure 7.
5. Insert the *Plastic Tube Plugs (H)* in *Leg Assemblies (B)*. See Figure 1.
6. Install *Seat End Caps (J)* using *#10 x 3/4" Sheet Metal Screws (K)*. See Figure 2.

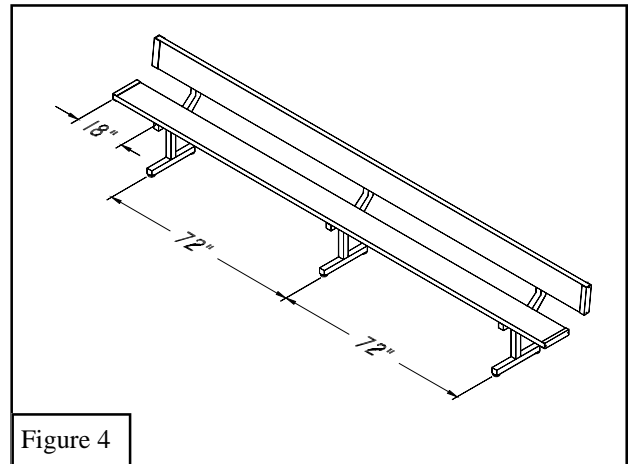

Figure 4

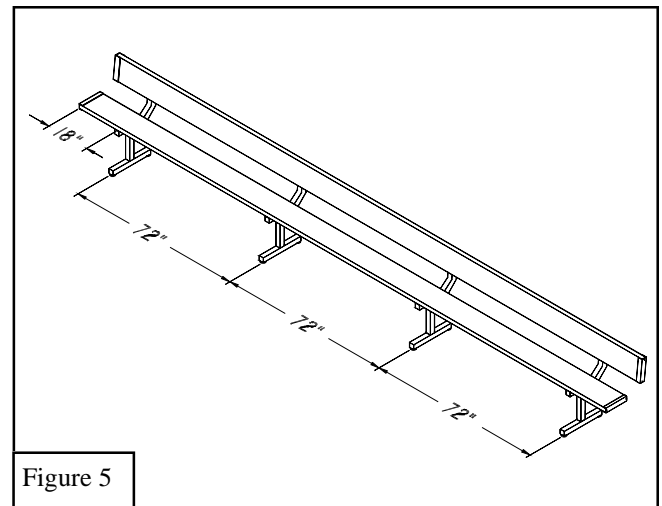

Figure 5

If Your Bench Is 21' In Length

1. Attach the *Leg Assemblies (B)* to the *21' Aluminum Seats (A)* with *3/8" x 3" Carriage Bolts (C)*, *3/8" Lock Washers (G)*, *3/8" Hex Nuts (F)* and *Bench Clamps (E)*. See Figure 1.
2. Place one *Leg Assembly (B)* 18" from each end. Position the remaining two *Leg Assemblies (B)* 72" from outside *Leg Assembly (B)* as shown. See Figure 5.
3. If you want the bench to be portable attach the *Rubber Feet (I)* to the *Leg Assemblies (B)* with *3/8" x 1 1/2" Hex Bolts (D)*, *3/8" Flat Washers (L)*, *3/8" Lock Washers (G)* and *3/8" Hex Nuts (F)*. See Figure 6.
4. If you want the bench to be fixed anchor each *Leg Assembly (B)* in 2 places using the appropriate anchors (not included) for the mounting surface. See Figure 7.
5. Insert the *Plastic Tube Plugs (H)* in *Leg Assemblies (B)*. See Figure 1.
6. Install *Seat End Caps (J)* using *#10 x 3/4" Sheet Metal Screws (K)*. See Figure 2.

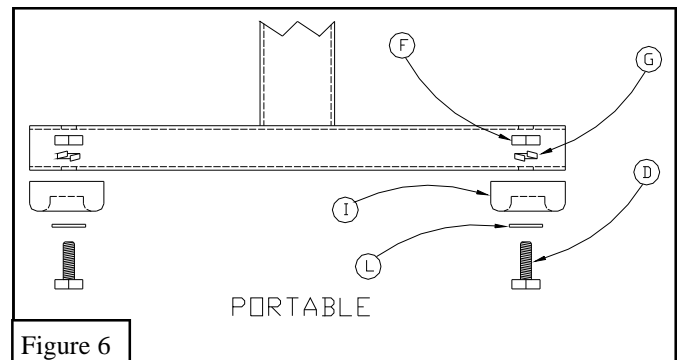

Figure 6

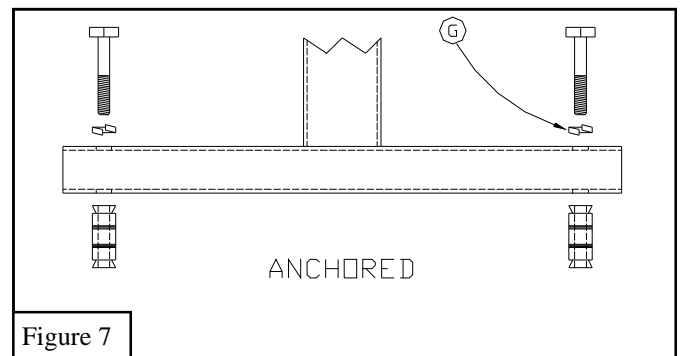

Figure 7