

VB25TF

Volleyball Anchor for Thin Floor Applications



Customer Service
(800) 247-7668

! WARNING !

**Tensioning of volleyball systems places significant stress on floor anchors.
Attachment to the wood only can cause significant damage to the floor.**

- ◆ Inspect all contents prior to installation. Report any missing parts to dealer immediately.
- ◆ Read all instructions before proceeding.

CONCRETE SUB FLOOR WITH DIRECTLY APPLIED TILE OR SYNTHETIC PLAYING SURFACE

1. Core drill a 1-1/4" diameter hole approximately 2" deep from the finished floor at the desired location of the VB25TF Insert.
2. Prepare a recess in the floor 3-1/2" in diameter, 3/8" deep centered on the core drilled hole to fit the insert flush with the playing surface.
3. Place the insert in the hole and mark the fastener hole locations, remove the insert and drill for the selected 5/16" concrete anchors.
4. Install insert into the floor using a non-shrink grout in the core drilled hole and the 5/16" flathead screws and anchors and let cure before use.

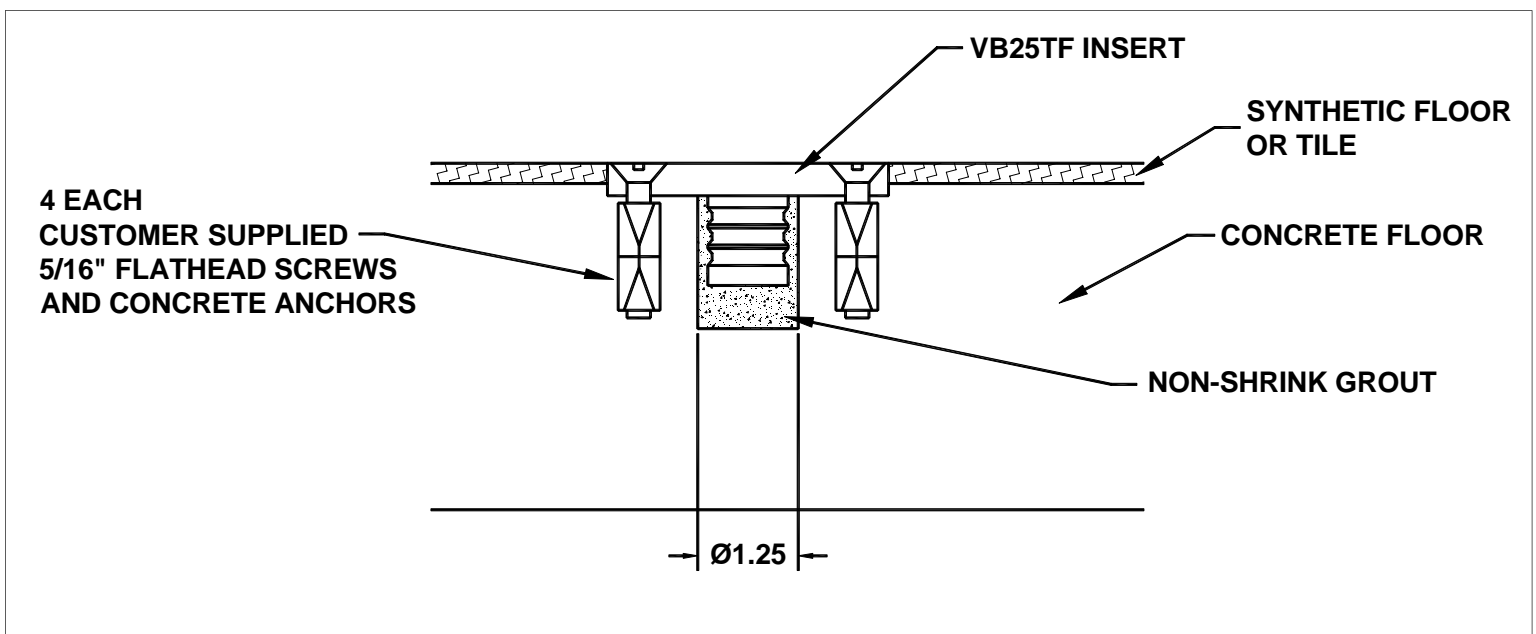

WOOD FLOATING FLOOR

1. Drill a 1-1/4" diameter hole through the wood floor and into the concrete approximately 2" deep from the playing surface at the desired location of the VB25TF Insert.
2. Carefully rout wood floor 3-1/2" in diameter, 3/8" deep centered around the drilled hole to fit the insert flush with the playing surface.
3. Place the insert in the hole and mark the fastener hole locations. Remove the insert drill a hole through the wood floor that allows for the drilling of the proper size holes in the concrete for the customer supplied concrete anchors.
4. Place the VB25TF insert into the floor using a non-shrink grout in the drilled hole and the 5/16" flat head screws and anchors and let cure before use.

