

Xtender36'

Home Batting Cage

Assembly Instructions

IMPORTANT

DO NOT RETURN THIS BATTING CAGE TO THE RETAIL STORE WHERE PURCHASED. **CALL TOLL FREE: (800) 492-9334**

IMPORTANT WARRANTY WARNING:

DO NOT LEAVE THE XTENDER CAGE ASSEMBLED DURING STRONG WIND, SNOW, SLEET, OR ICE STORMS. THE XTENDER IS NOT DESIGNED TO WITHSTAND EXTREME WEATHER CONDITIONS AND DAMAGE TO THE FIBERGLASS FRAMES CAUSED BY EXTREME WEATHER MAY NOT BE COVERED IN THE MANUFACTURERS WARRANTY.

WARNING:

USE THIS PRODUCT WITH ADULT SUPERVISION ONLY. SERIOUS BODILY INJURY MAY OCCUR!
READ WARNING LABELS CAREFULLY.



PARTS LIST

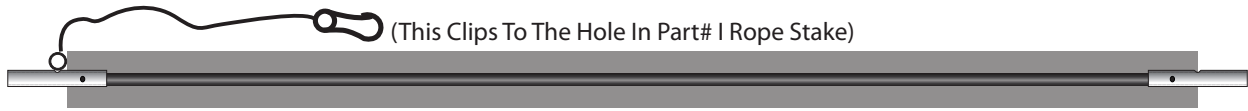

Part# A-1 (Quantity 3) - 44" Long - **End & Middle Pole Assemblies**
Fiberglass Rod with Foam Pad

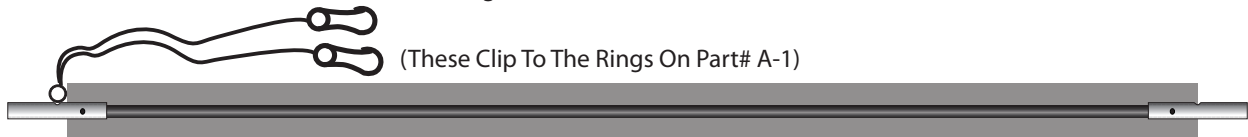

Part# A-2 (Quantity 1) - 44" Long - **End & Middle Pole Assemblies**
Fiberglass Rod with Foam Pad



Part# B (Quantity 4) - 44" Long - **End Pole Assembly**
Metal Fitting/Ring & Fiberglass Rod with Foam Pad & Rope Tie Stake

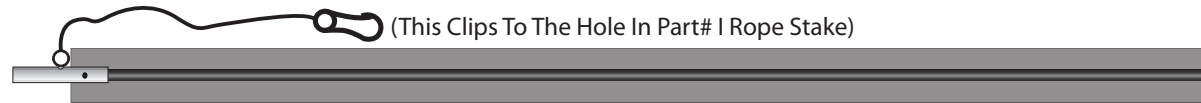

Part# B-1 (Quantity 5) - 44" Long - **End Pole Assembly**
Metal Fitting/Ring & Fiberglass Rod with Foam Pad & Rope Tie Stake

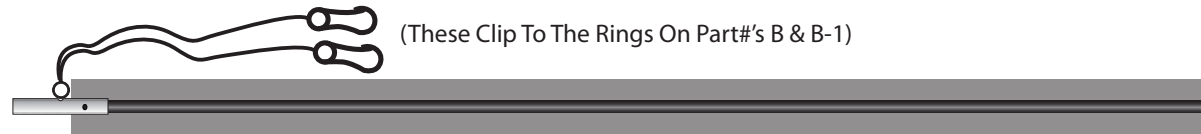

Part# B-2 (Quantity 3) - 44" Long - **Middle Pole Assembly**
Metal Fitting/Ring & Fiberglass Rod with Foam Pad & Rope Hook Tie



Part# C (Quantity 8) - 44" Long - **Middle Pole Assembly**
Metal Fitting/Ring & Fiberglass Rod with Foam Pad & Swedged Tubular End & Rope Hook Tie



Part# D (Quantity 8) - 44" Long - **End & Middle Pole Assemblies**
1.25" Steel Tube with Foam Pad



Part# E (Quantity 2) - 14" Long
Black Rope with Loop on the End

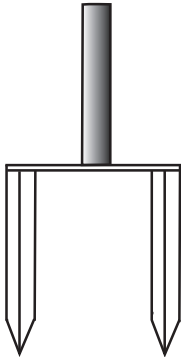

Part# F - (Quantity 8)
Ground Stake



Part# G - (Quantity 1)
Roll Of Black Tape

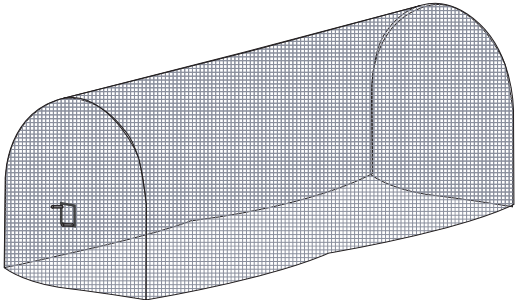

Part# H - (Quantity 1)
Batting Cage Net



Part# I - (Quantity 4)
Rope Stake

STEP 1: Pound Ground Stake (Part# F) Into Ground 12 Feet Apart From Each Other (8X).

Note: Make Sure Stakes Are Perfectly Straight Up And Down.

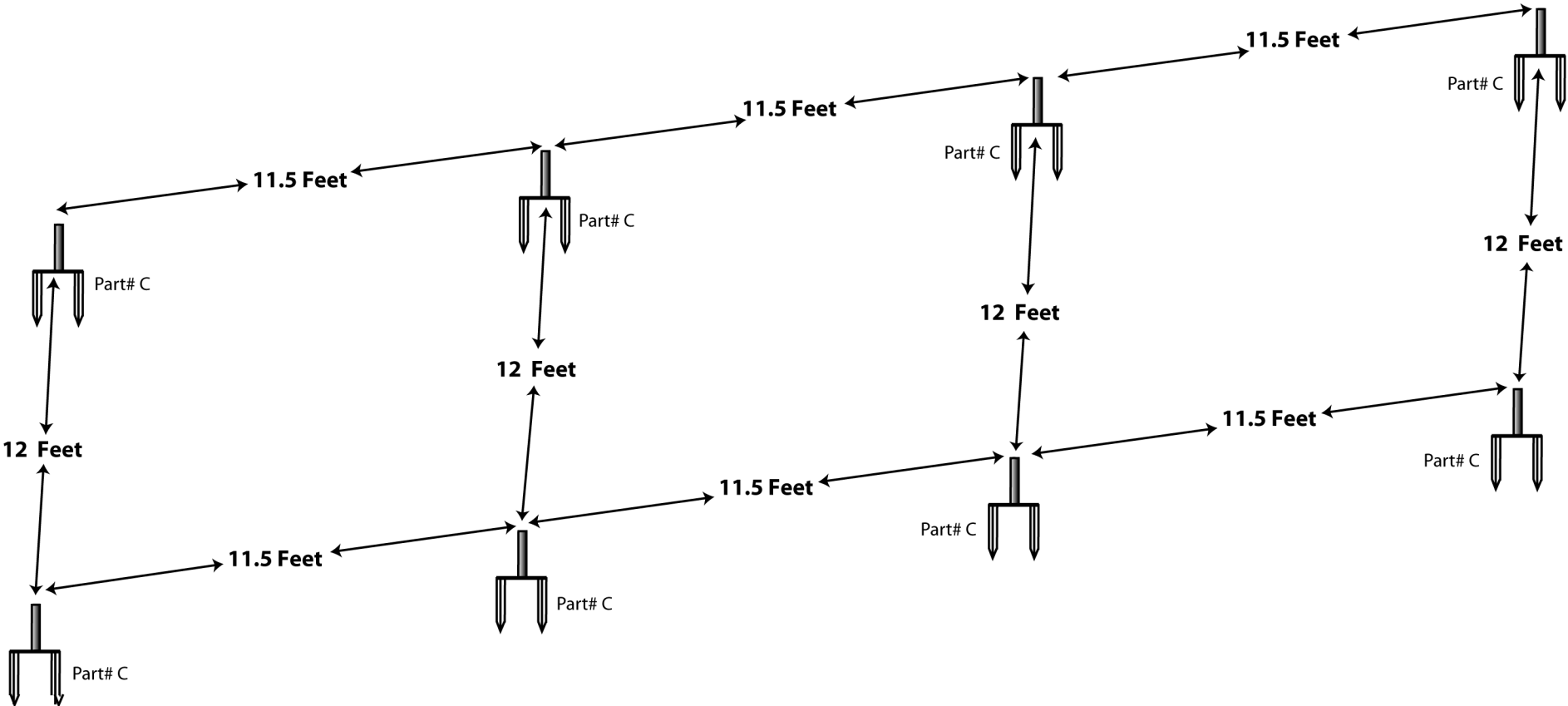

Do Not Return This Product To The Store.
Call Toll Free: 1-800-492-9334 For Customer Service.

Model# XT399

STEP 2: END POLE Assemblies (Quantity 2)

(Refer to Part #'s Below.)

Slide each section together and tape. Repeat for the second End Pole Assembly.

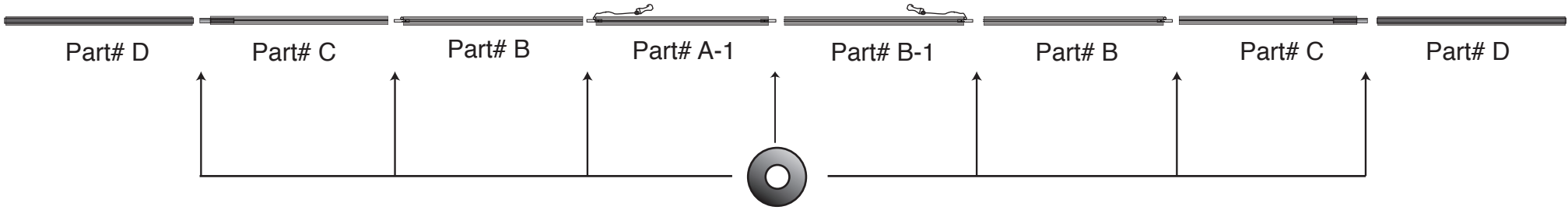

Part# G Tape each section together with Black Tape.

STEP 3: MIDDLE POLE Assembly-1 (Quantity 1)

(Refer to Part #'s Below.)

Slide each section together and tape.

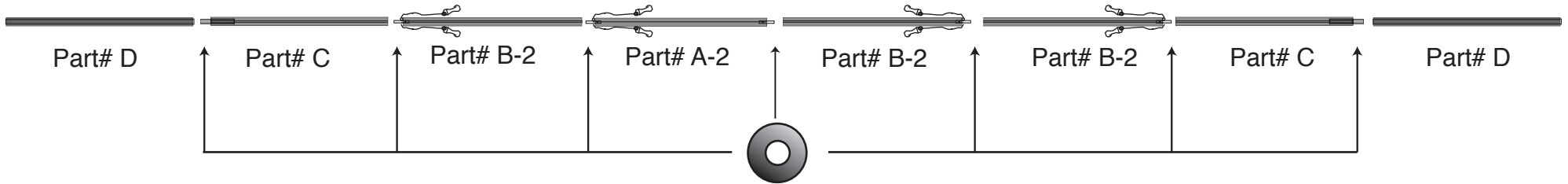

Part# G Tape each section together with Black Tape.

STEP 4: MIDDLE POLE Assembly-2 (Quantity 1)

(Refer to Part #'s Below.)

Slide each section together and tape.

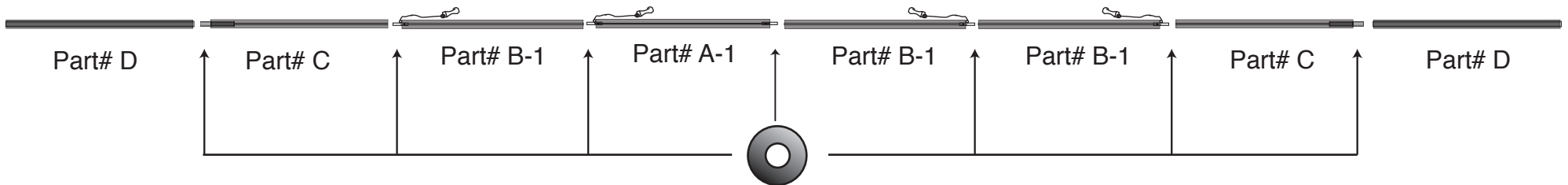

Part# G Tape each section together with Black Tape.

STEP 5: Clip Net Support Ropes to Rings on End Pole Assembly (2X).

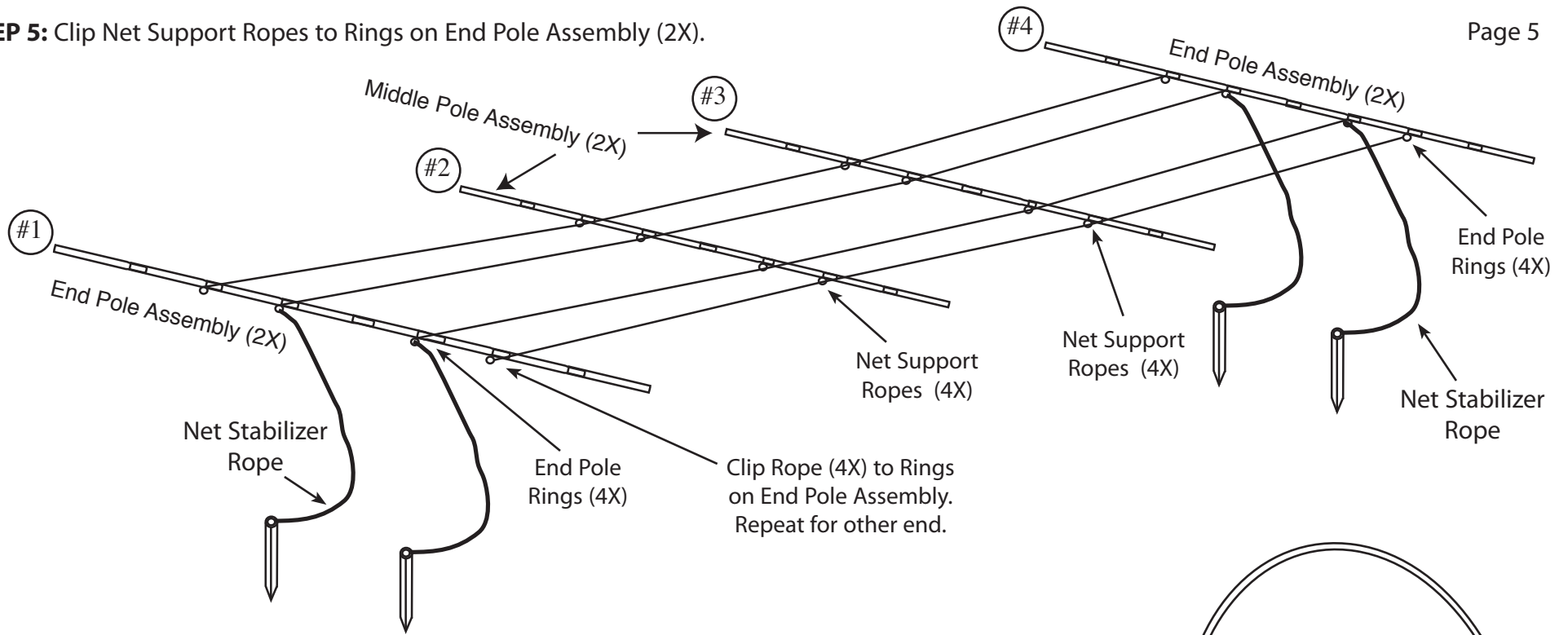

STEP 6: Lift End Pole Assembly vertically and slide Part# D of End Pole Assembly over Ground Stake (Part# F).

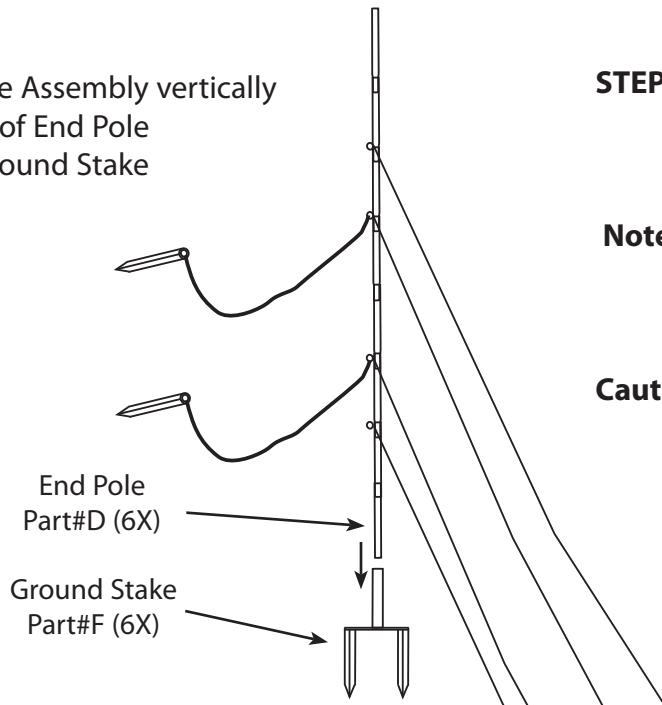

STEP 7: Bend End Pole Assembly into an arc & slide the other end of Part# D over Part# F (Ground Stake).

Note: Repeat for each Middle Pole Assembly and the other End Pole Assembly.

Caution: Excessive bending will break Pole Assembly. Exercise caution when bending pole assemblies.

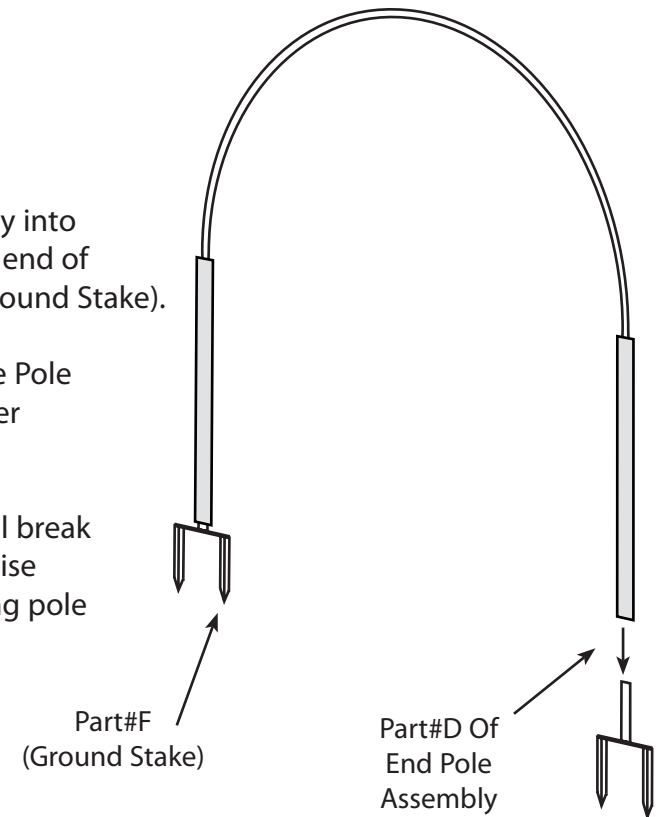

STEP 8: Hammer Rope Stake (Part# 1) into ground and tie Stabilizer Rope onto Rope Stake hole (8X). Make sure rope is tight.

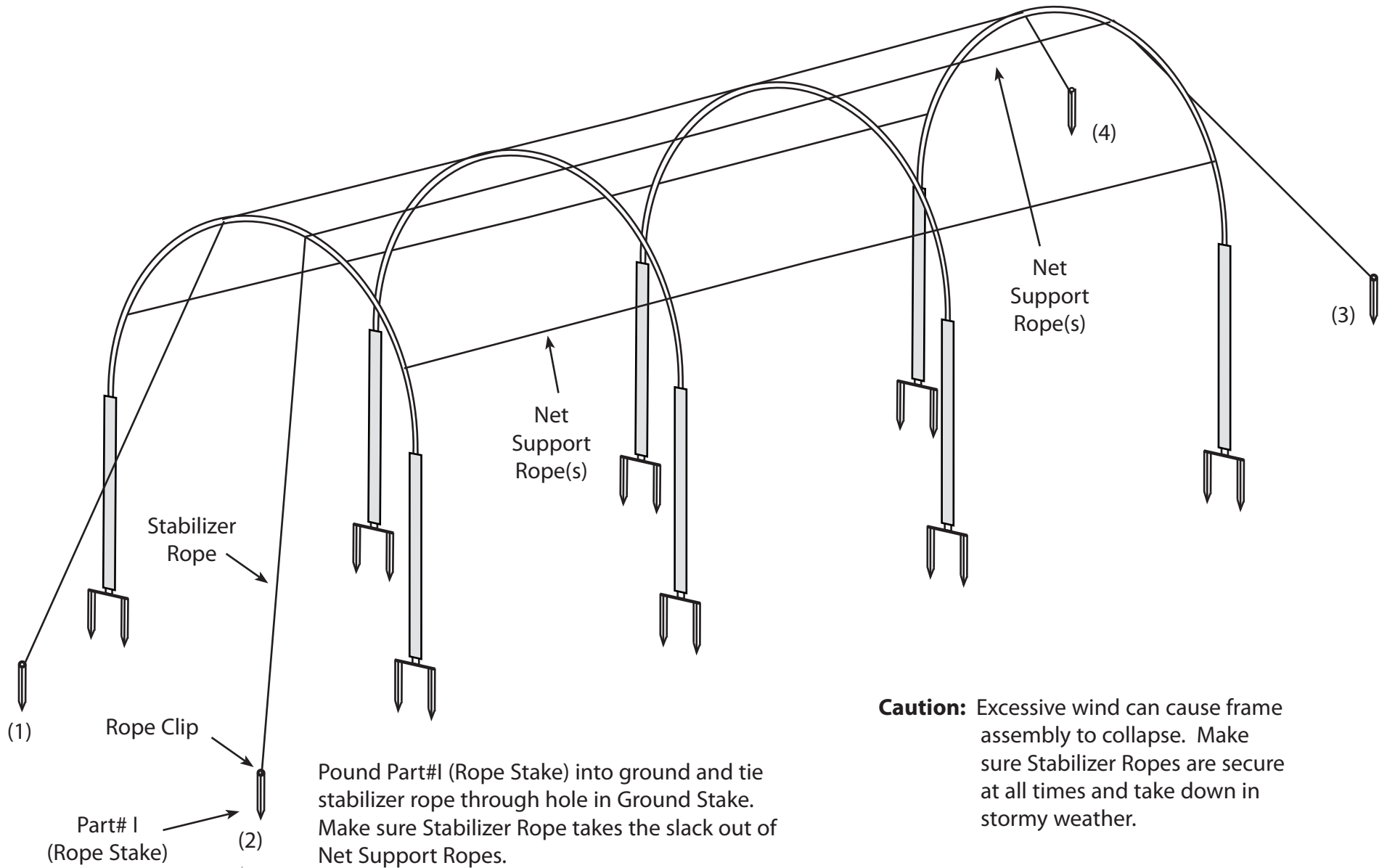

Pound Part#1 (Rope Stake) into ground and tie stabilizer rope through hole in Ground Stake. Make sure Stabilizer Rope takes the slack out of Net Support Ropes.

Repeat for all (4) corners.

Caution: Excessive wind can cause frame assembly to collapse. Make sure Stabilizer Ropes are secure at all times and take down in stormy weather.

STEP 9: Where Part# D And Part# C join together (Middle Pole Assembly), wrap straight end of Part# E (Black Rope With Loop) around Middle Pole Assembly joint, slip through Part# E Loop and pull tight.

Wrap straight end of Part# E (Black Rope with Loop) around joint of Part# D and Part# C (End Pole Assembly), pull tight, and tie a knot.

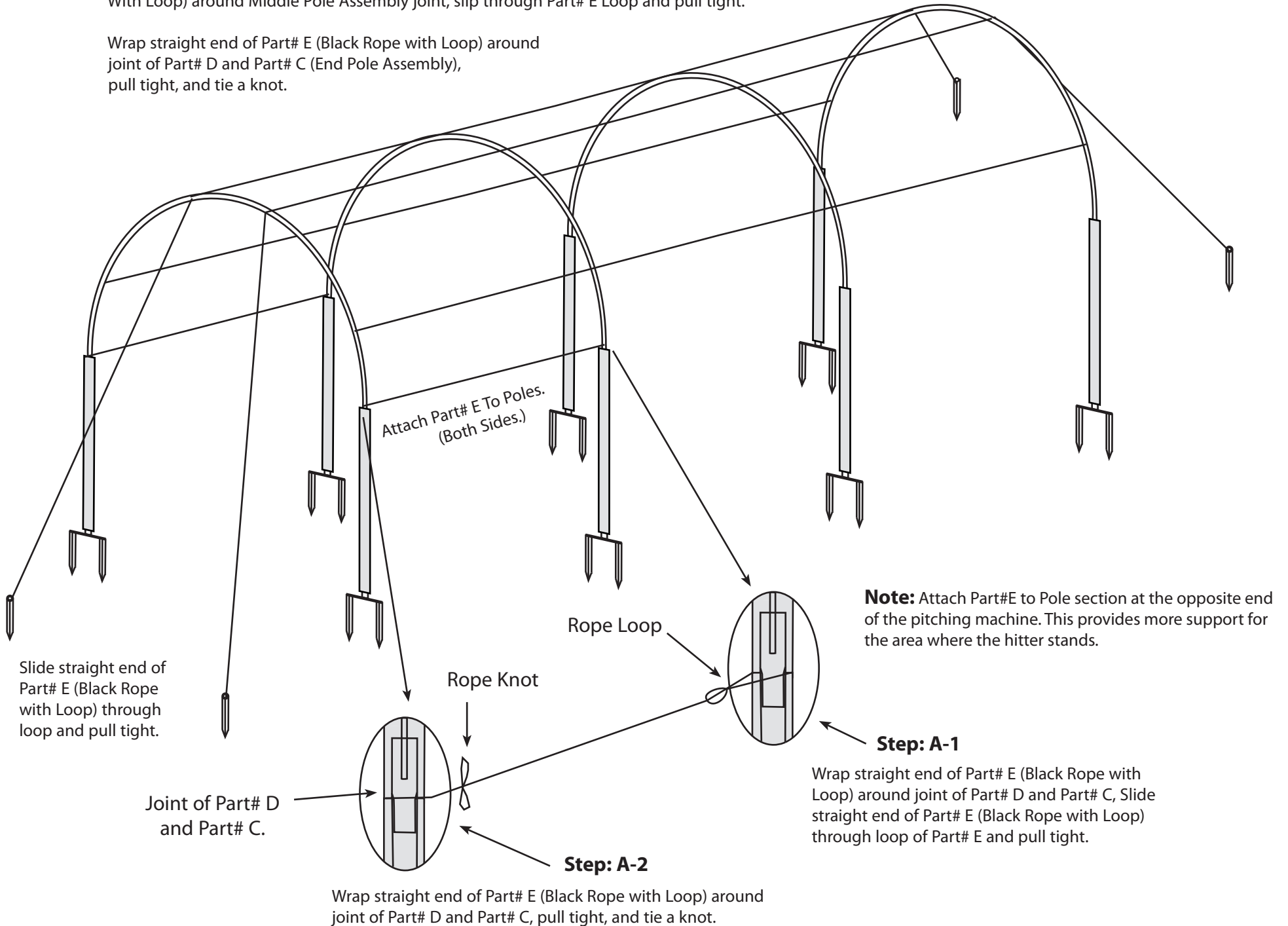

Note: Attach Part#E to Pole section at the opposite end of the pitching machine. This provides more support for the area where the hitter stands.

Step: A-1

Wrap straight end of Part# E (Black Rope with Loop) around joint of Part# D and Part# C, Slide straight end of Part# E (Black Rope with Loop) through loop of Part# E and pull tight.

Step: A-2

Wrap straight end of Part# E (Black Rope with Loop) around joint of Part# D and Part# C, pull tight, and tie a knot.

Slide straight end of Part# E (Black Rope with Loop) through loop and pull tight.

Joint of Part# D and Part# C.

Attach Part# E To Poles. (Both Sides.)

Rope Loop

Rope Knot

STEP 10: Unfold Part# H (Batting Cage Net) and lay out long ways on the ground. Gently begin placing Part# H (Batting Cage Net) over the assembled frame.

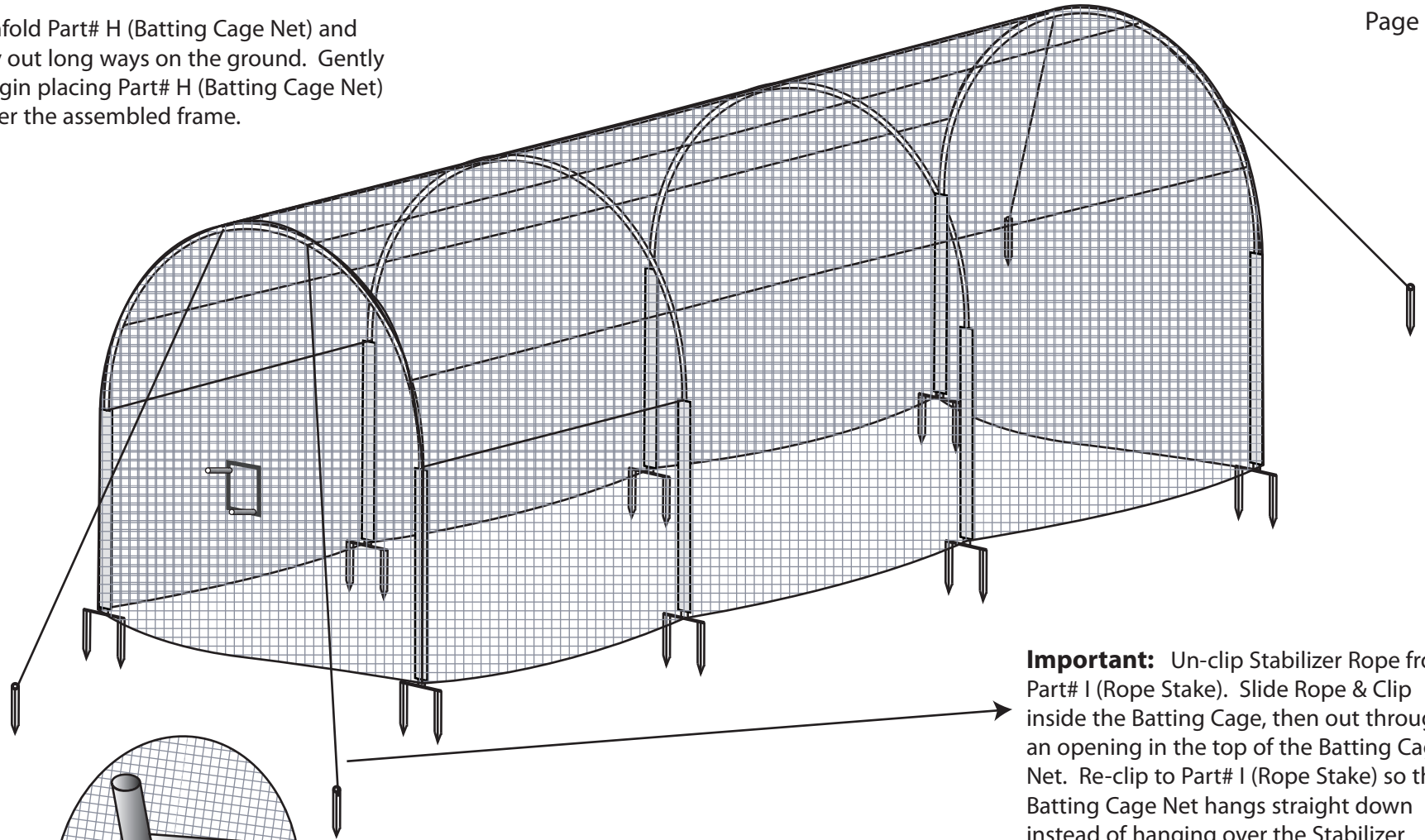

CORRECT
Batting Cage Net
Harness Tubes
on the Left Side
and Bottom Side
of Net Frame.

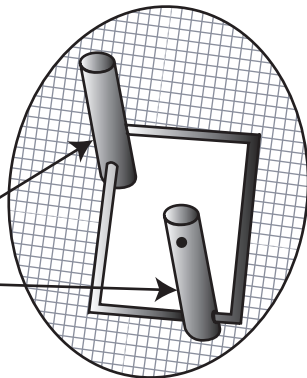

Tubes should be sticking out of Batting Cage.

INCORRECT
Batting Cage Net
Harness Tubes
on the Top Side
and Bottom Side
of Net Frame.

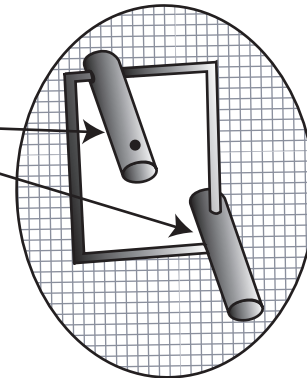

Important: Un-clip Stabilizer Rope from Part# I (Rope Stake). Slide Rope & Clip inside the Batting Cage, then out through an opening in the top of the Batting Cage Net. Re-clip to Part# I (Rope Stake) so the Batting Cage Net hangs straight down instead of hanging over the Stabilizer Ropes.

NOTE: If batting cage harness is **incorrect**, you have put on the batting cage net inside out. Please take off batting cage net and reverse. Put inside of net to the outside of the cage and the outside of the net to the inside of the cage.

OPTIONAL ACCESSORY (Sold Separately):

You can purchase any Heater Sports Pitching Machine product to attach to the Xtender Home Batting Cage.

Call Toll Free: 1-800-492-9334 to locate a retail store near you.

STEP 11:

Slide Batting Cage
Harness Tubes (2X) Into
Pitching Machine Harness
Tubes And Lock Into Place
With Push Pins.

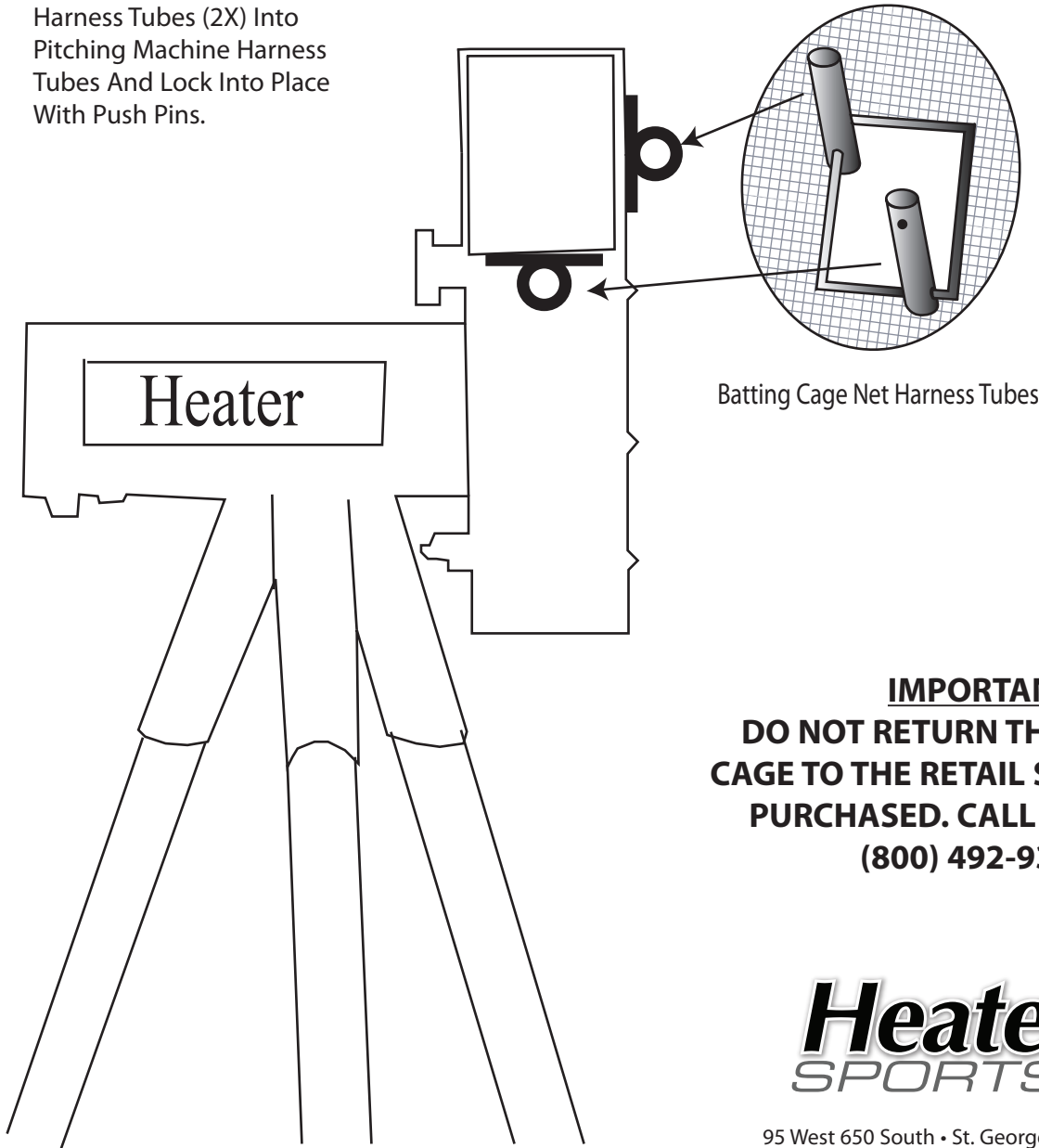

Batting Cage Net Harness Tubes

IMPORTANT
DO NOT RETURN THIS BATTING
CAGE TO THE RETAIL STORE WHERE
PURCHASED. CALL TOLL FREE:
(800) 492-9334.



WARNING

Make sure Heater Sports Pitching Machine is turned off and unplugged when attaching Batting Cage Net Harness Tube to Heater Sports Pitching Machine.

WARNING!

- Never allow a batter in the Batting Cage until the Trend Sports Pitching Machine has been sighted in and pitching at the desired target and at the right speed.
- Make sure Heater Sports Pitching Machine is turned off and unplugged when attaching the Batting Cage Net Harness Tube to the Heater Sports Pitching Machine.
- Make sure and disassemble the Xtender Batting Cage in stormy weather. The cage could break or blow over and cause property damage.
- Make sure area around batting cage is clear of people except for batter and machine operator. Bodily injury could occur if proper safety precautions aren't followed.

Xtender36'

Optional: Joining 2 Cages *(Must purchase 2 separate cages)* **INSTRUCTIONS**

Step #1

Fully assemble both batting cages and place them end-to-end 4-2 inches apart.

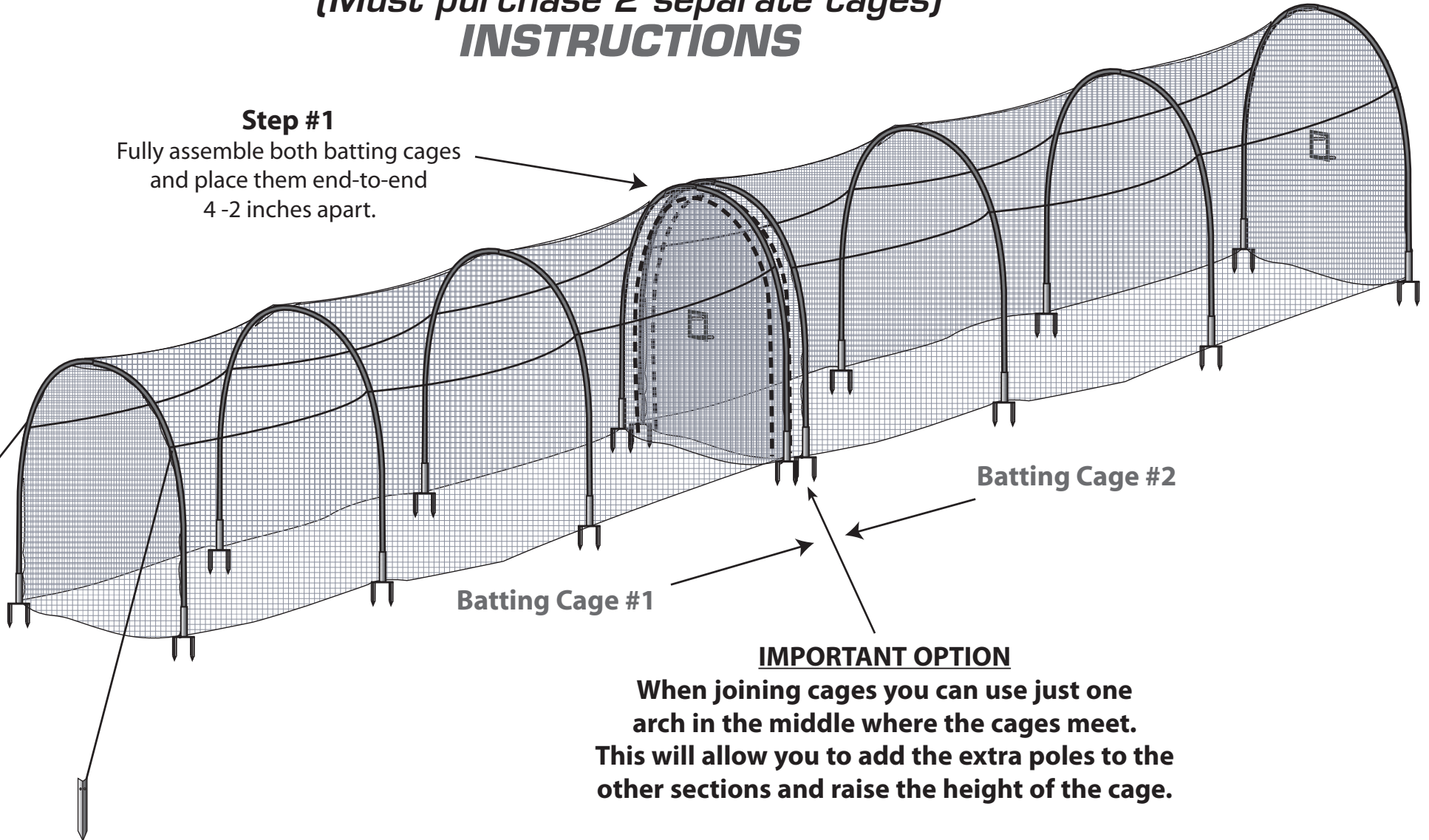

IMPORTANT OPTION

When joining cages you can use just one arch in the middle where the cages meet. This will allow you to add the extra poles to the other sections and raise the height of the cage.

Joining 2 Cages INSTRUCTIONS

Step #2

Match the red reinforced seams together where the cages meet. Using the **extra support ropes** weave the two cages together.

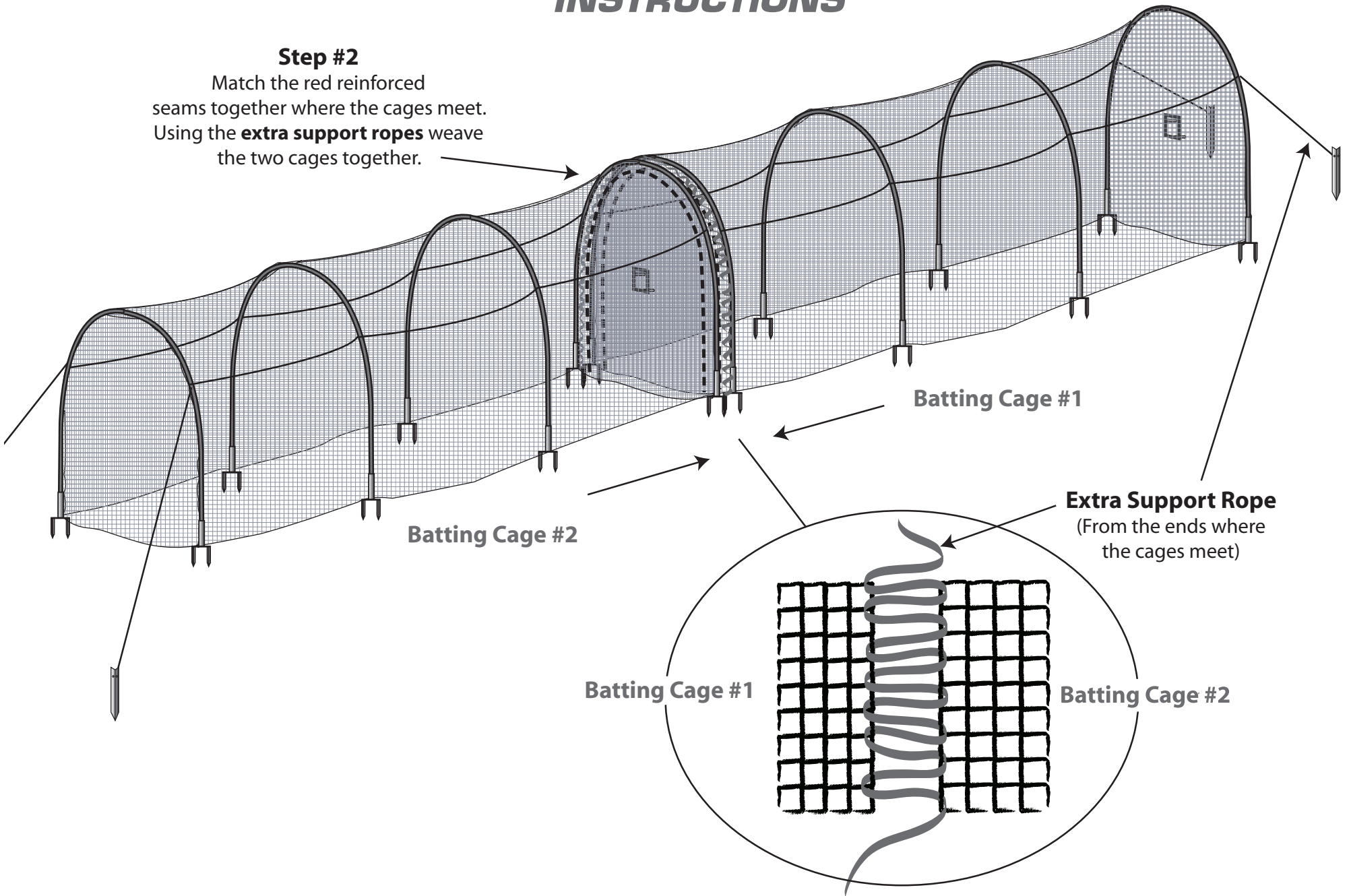

Joining 2 Cages INSTRUCTIONS

Step #4

Using scissors, cut an opening in the netting where the stitched netting come together on both cages.

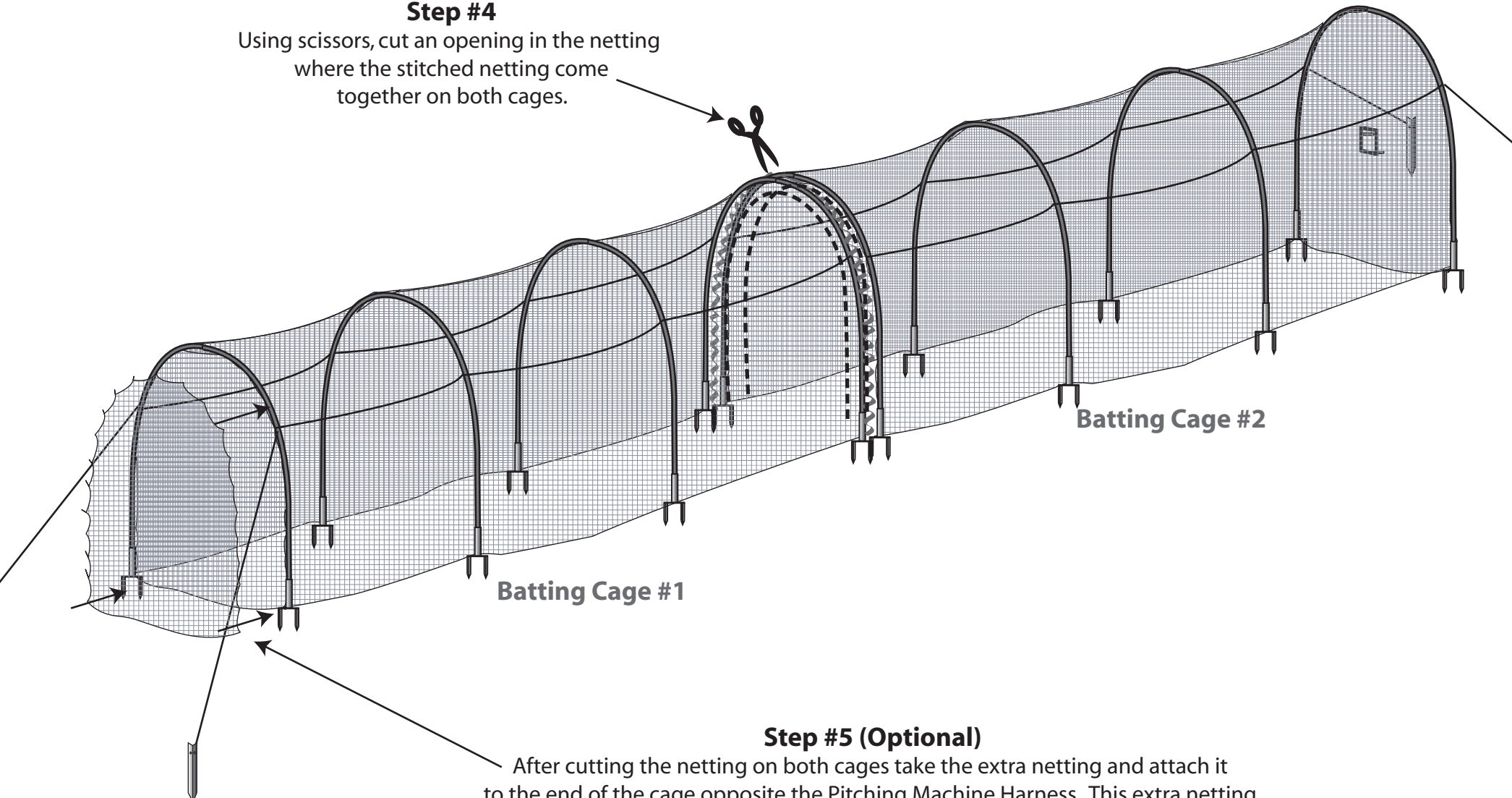

Step #5 (Optional)

After cutting the netting on both cages take the extra netting and attach it to the end of the cage opposite the Pitching Machine Harness. This extra netting will provide additional support and cushioning to the backstop area.