



Home Batting Cage

Assembly Instructions

IMPORTANT

DO NOT RETURN THIS BATTING CAGE TO THE RETAIL STORE WHERE PURCHASED. **CALL TOLL FREE: (800) 492-9334**

IMPORTANT WARRANTY WARNING:

DO NOT LEAVE THE POWERALLEY CAGE ASSEMBLED DURING STRONG WIND, SNOW, SLEET, OR ICE STORMS. THE POWERALLEY IS NOT DESIGNED TO WITHSTAND EXTREME WEATHER CONDITIONS AND DAMAGE TO THE FIBERGLASS FRAMES CAUSED BY EXTREME WEATHER MAY NOT BECOVERED IN THE MANUFACTURERS WARRANTY.

WARNING:

USE THIS PRODUCT WITH ADULT SUPERVISION ONLY. SERIOUS BODILY INJURY MAY OCCUR!
READ WARNING LABELS CAREFULLY.



PARTS LIST

Model# PA199

Fiberglass Poles (Quantity - 3 Pole Sets)

Part A
(21 pieces)

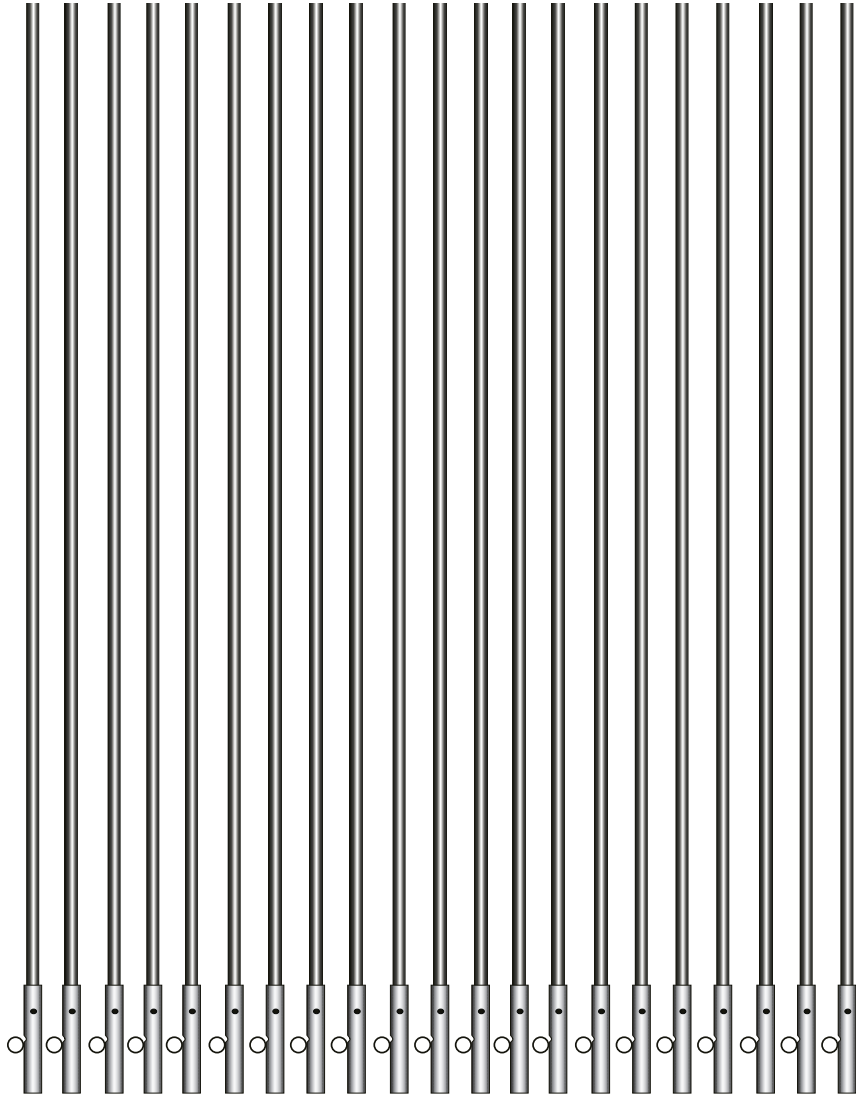

Part B
(3 piece)

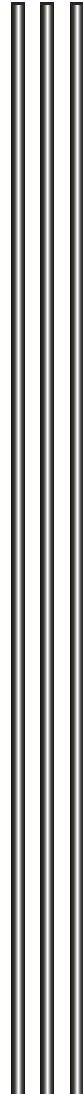

Rope Stakes & Support Ropes (White)

(Quantity - 4)
Part E

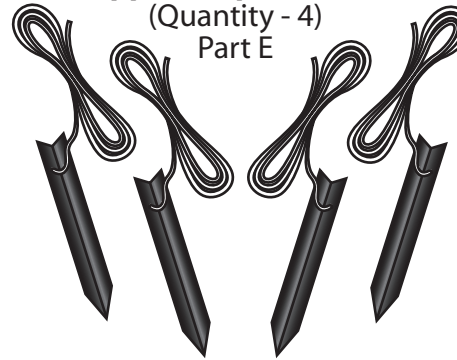

Black Guide Ropes

(Quantity - 8)
Part F

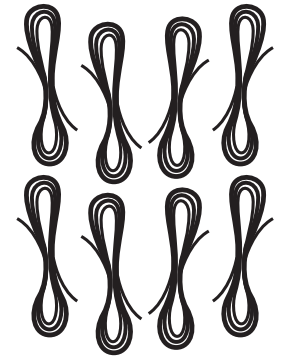

Roll Of Black Tape
Part J



Poly Netting with Pitching Machine Harness

Part H

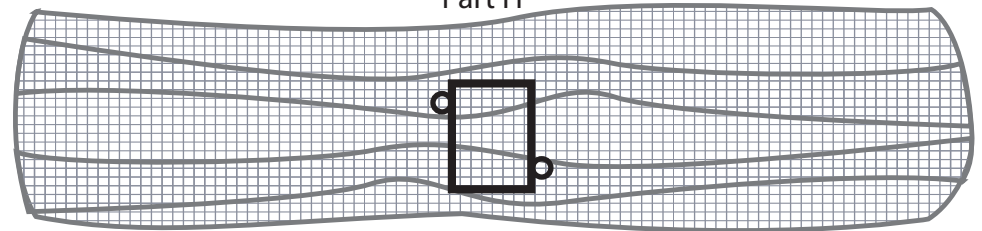

6 - Ground Stakes

Part I

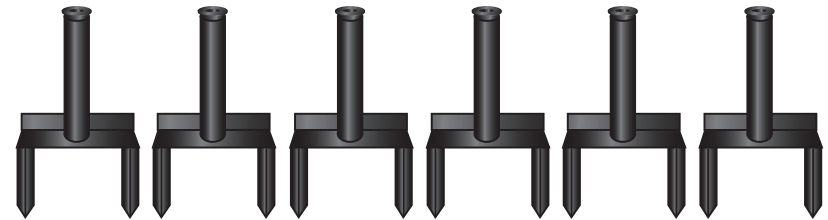

PA199 - Power Alley Battnng Cage

Replacement Parts List

Rev. 2010-04

<u>Part No.</u>	<u>Description</u>	<u>Qty Pack</u>	<u>Price</u>
Part A	Power Alley Pole With Metal Tip & Loop	1	7.99
Part B	Power Alley Pole Without Tip & Loop	1	4.99
Part C	Metal Pole Tip & Loop Only	1	2.99
Part C-1	Complete Arch Assembly	1	39.99
Part D	White Ropes For Metal Rope Stakes	1	0.50
Part E	Metal Rope Stakes	1	4.49
Part F	Black Guide Ropes	2	1.00
Part G	Pitching Machine Harness Only	1	19.99
Part H	Poly Netting With Pitching Machine Harness	1	99.99
Part I	Ground Stake	1	9.99
Part J	Ground Stake Plastic Insert Only	1	2.99

*Call For Qty Price Break When Ordering More Than 1 Part

Tab: PA199PartsList&PricingRev201004

M:\WorldSports\BLDG 03. MERCHANDISING, R&D, AND MARKETING\

10. R&D-PROTOTYPE DEVELOPMENT TO NTE THRU TARGET COGS-DESIGN\

03. Mechanical Engineering & Drafting\01. Parts Products Catalogs\AllProducts.xls

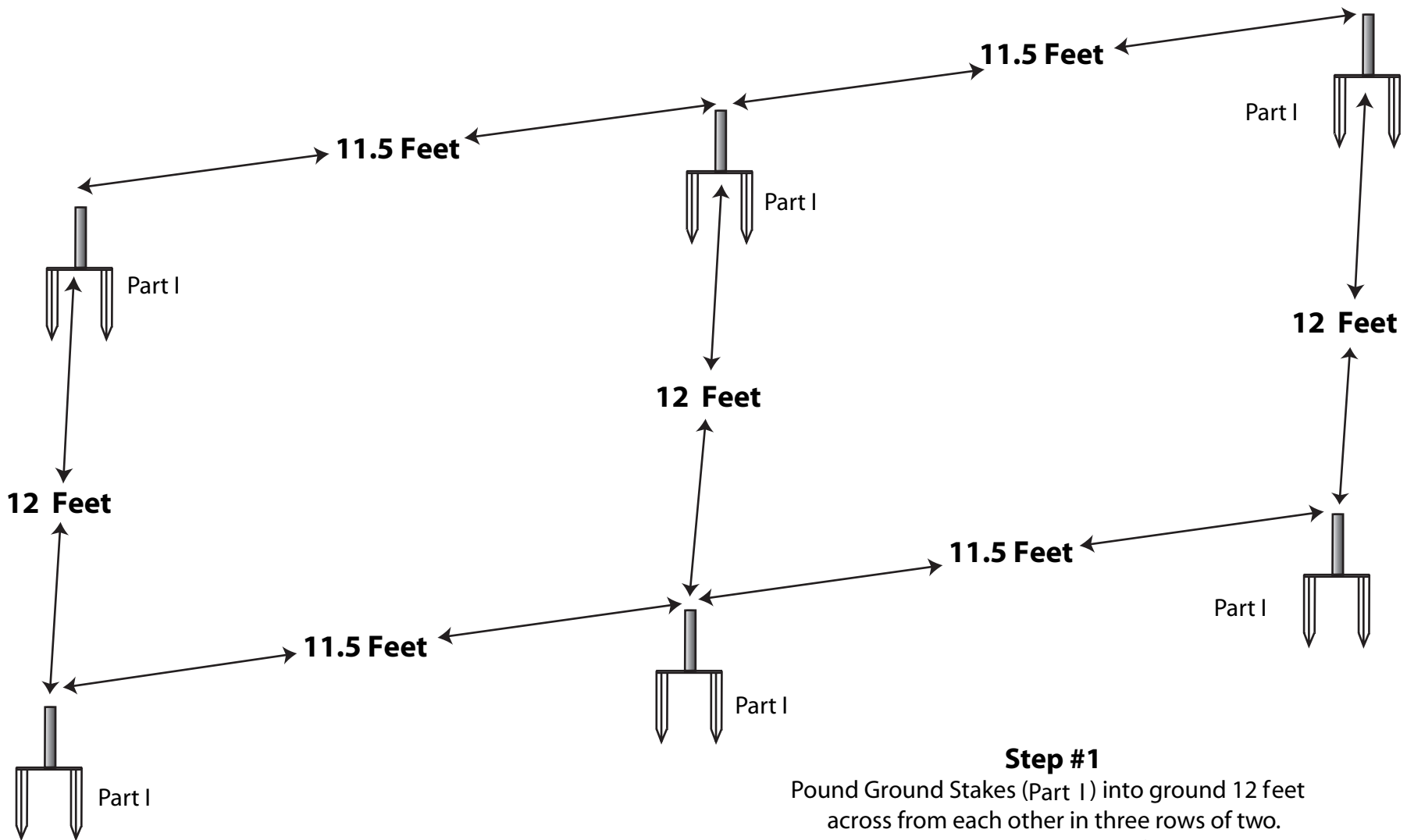

Step #1

Pound Ground Stakes (Part I) into ground 12 feet
across from each other in three rows of two.

Each row needs to be 11.5 feet apart.

(See diagram)

Note: Make Sure Stakes Are Perfectly Straight Up And Down.

Step #2

Connect 8 Fiberglass Rods to one of three Pole Sections following the illustration to the right.

(Note: Make sure the guide rope rings are positioned on the same side of the pole assembly)

Repeat the process to complete three pole sections

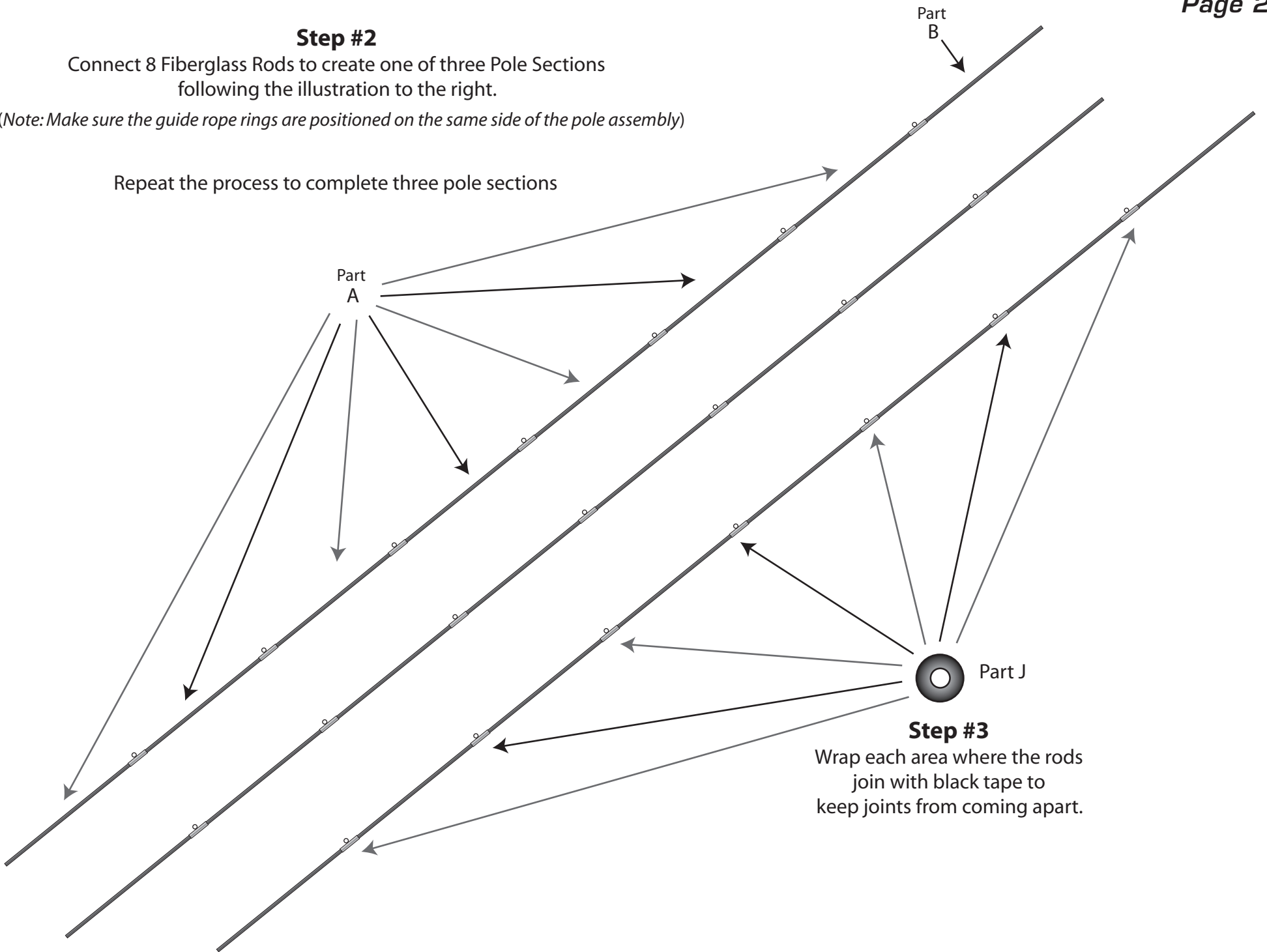

Step #3

Wrap each area where the rods join with black tape to keep joints from coming apart.

Step #4

Insert each of the fiberglass pole ends into the ground stakes by arching the poles to form the cage.

Note: When forming the poles into an arch, make sure to face the rope rings on the joint fittings inward so that the netting slides over the frames easily.

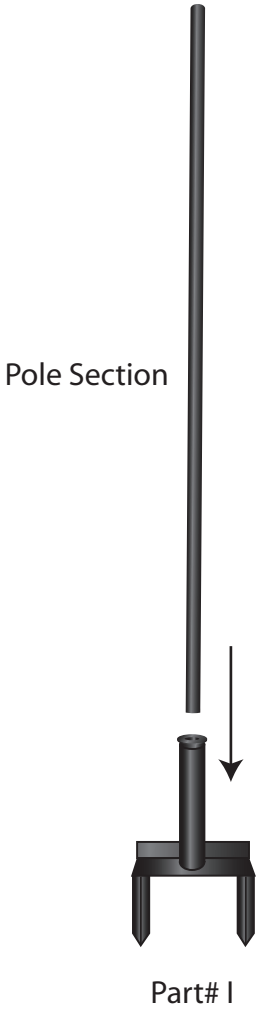

Step #5

Take the Black Guide Ropes (Part F), and attach the ropes to the rope rings as indicated in the illustration below.

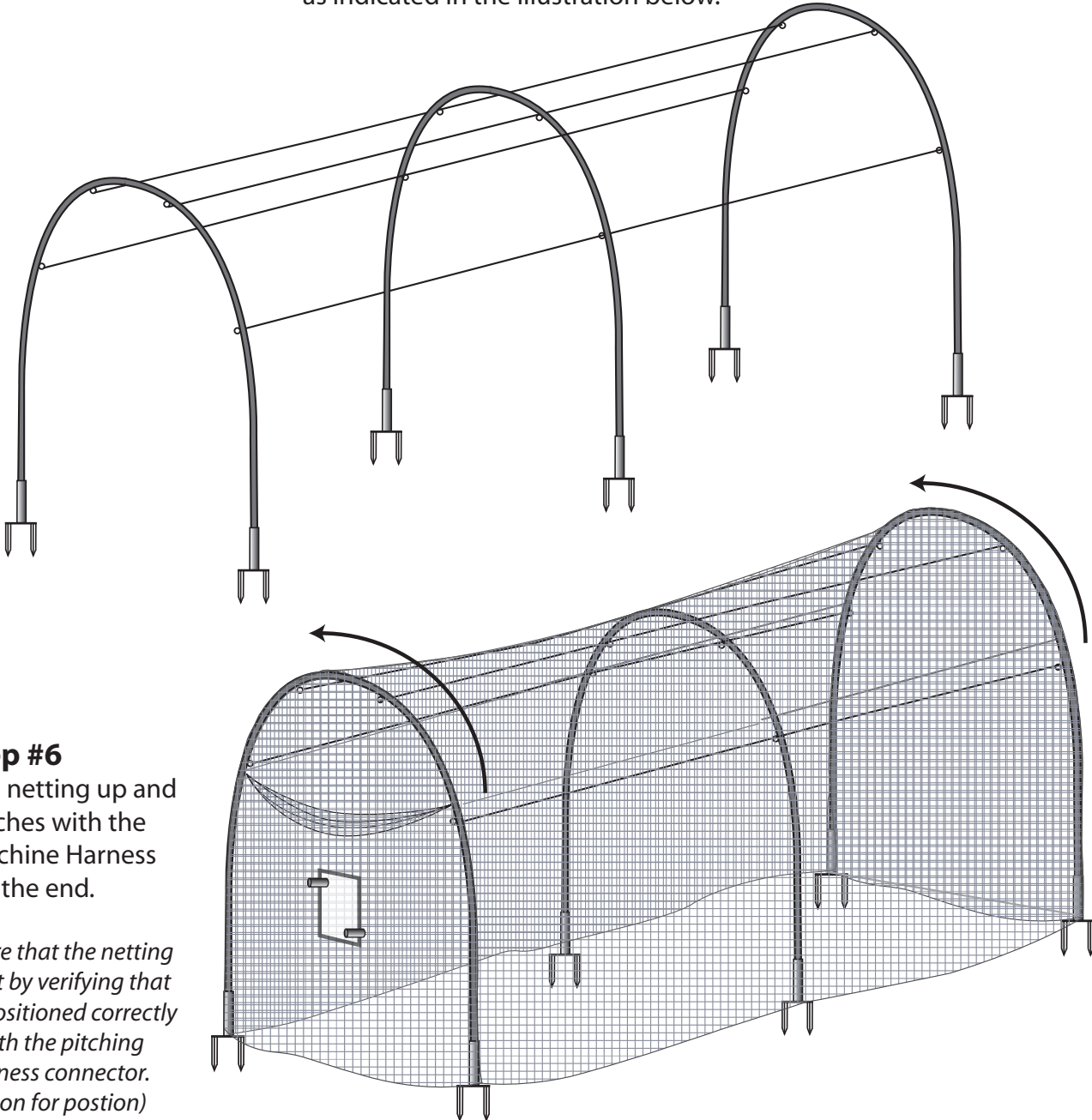

Step #6

Next, slide the netting up and over the arches with the Pitching Machine Harness facing the end.

Note: Make sure that the netting is right-side-out by verifying that the harness is positioned correctly to line-up with the pitching machine harness connector. (See Illustration for position)

Step #7

Tie the White Support Ropes to the guide rope rings as indicated in the illustration below.
Pull the Support Ropes tight, and drive the Ground Stakes into the ground.

Note: To achieve the ultimate cage shape you may need to adjust the Black Guide Ropes to allow for the correct tension between the arched pole sections.
Also adjust the support ropes as needed to maintain the desired cage height.

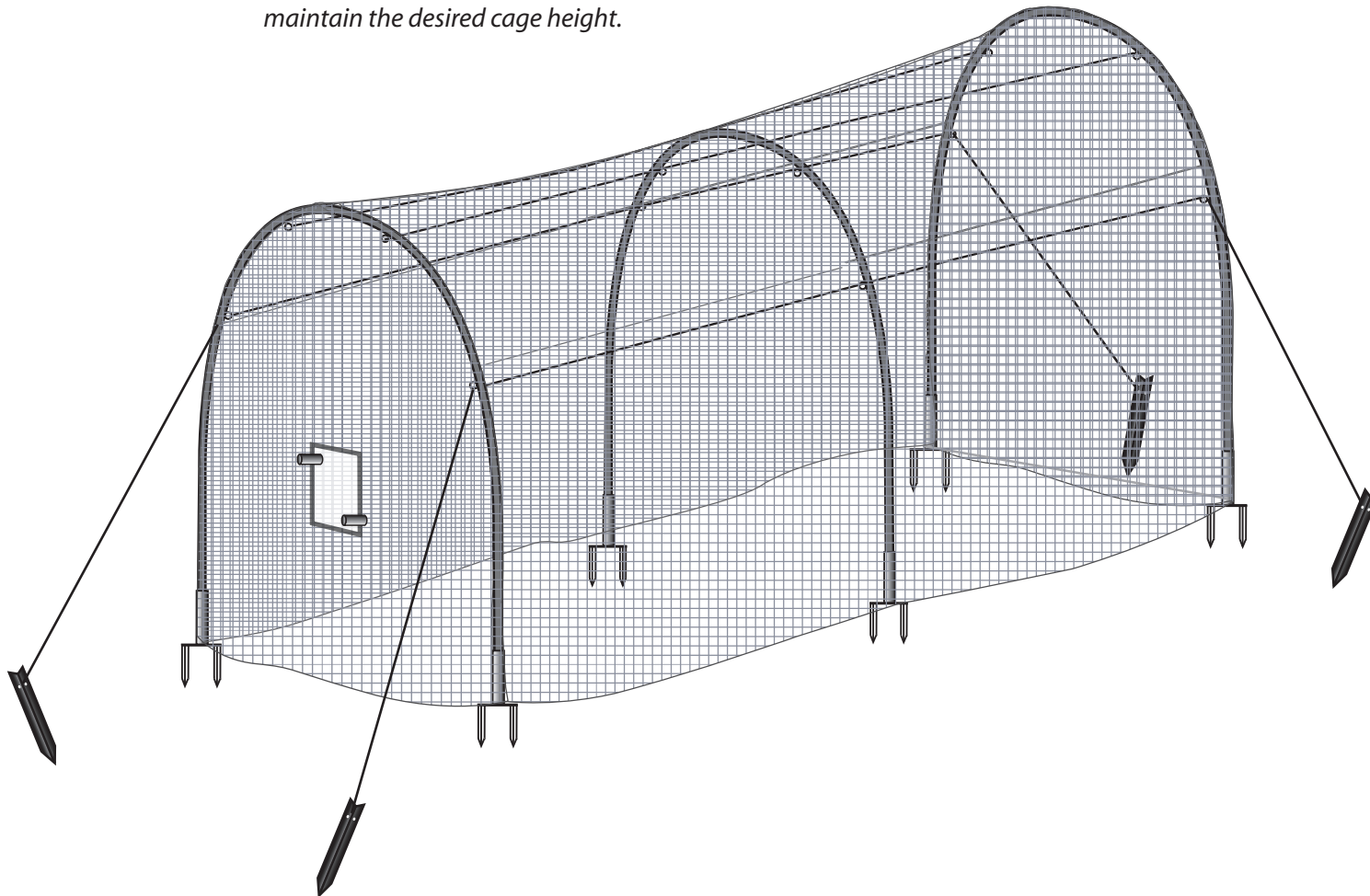

Pitching Machine Harness Connection

Heater Pitching Machines and Batting Cages are specifically designed to connect so that the pitching machine can remain outside the batting cage. This provides protection for the pitching machine and the machine operator.

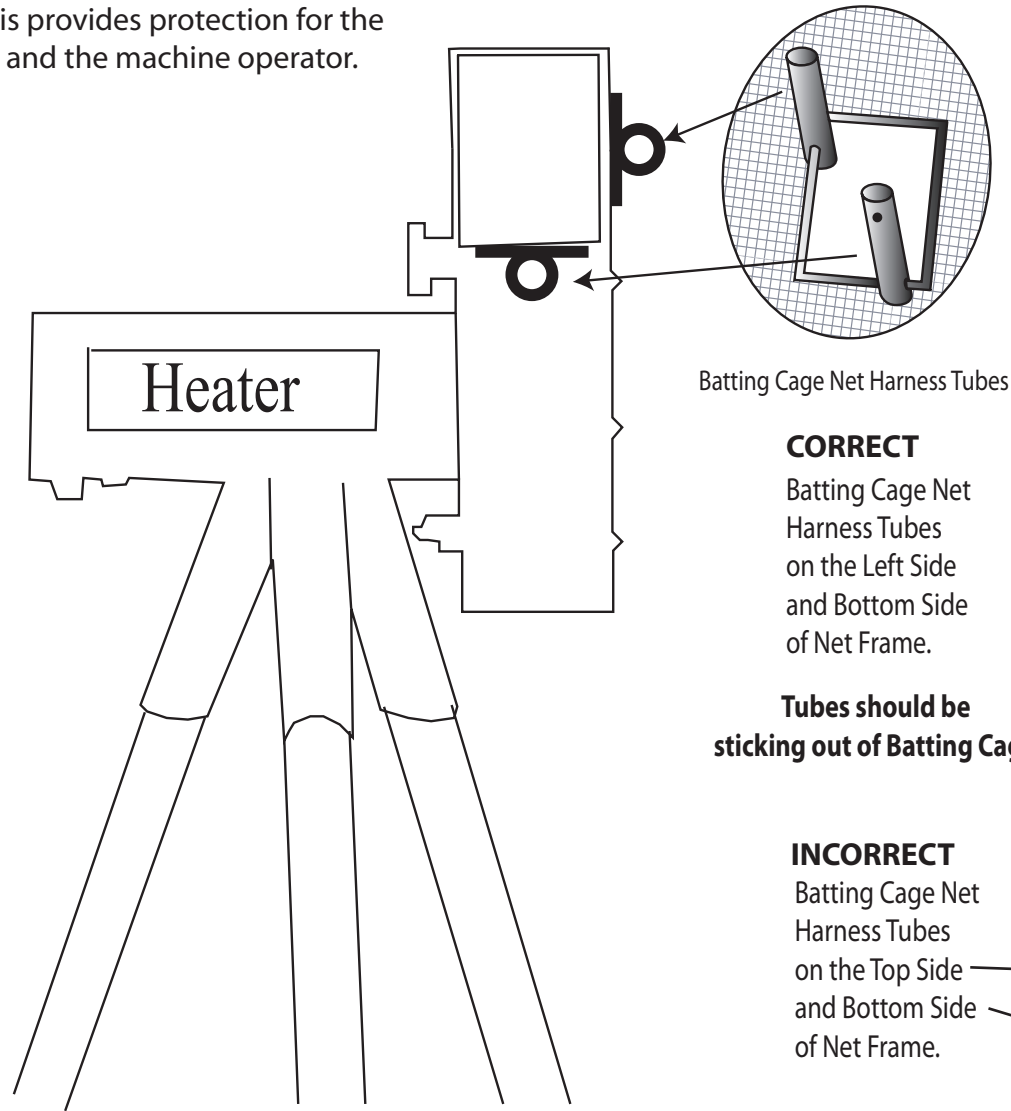

Batting Cage Net Harness Tubes

CORRECT

Batting Cage Net Harness Tubes on the Left Side and Bottom Side of Net Frame.

Tubes should be sticking out of Batting Cage.

INCORRECT

Batting Cage Net Harness Tubes on the Top Side and Bottom Side of Net Frame.

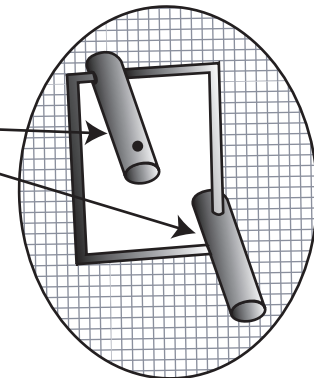



Joining 2 Cages INSTRUCTIONS

Step #1

Fully assemble both batting cages
and place them end-to-end
4 -2 inches apart.

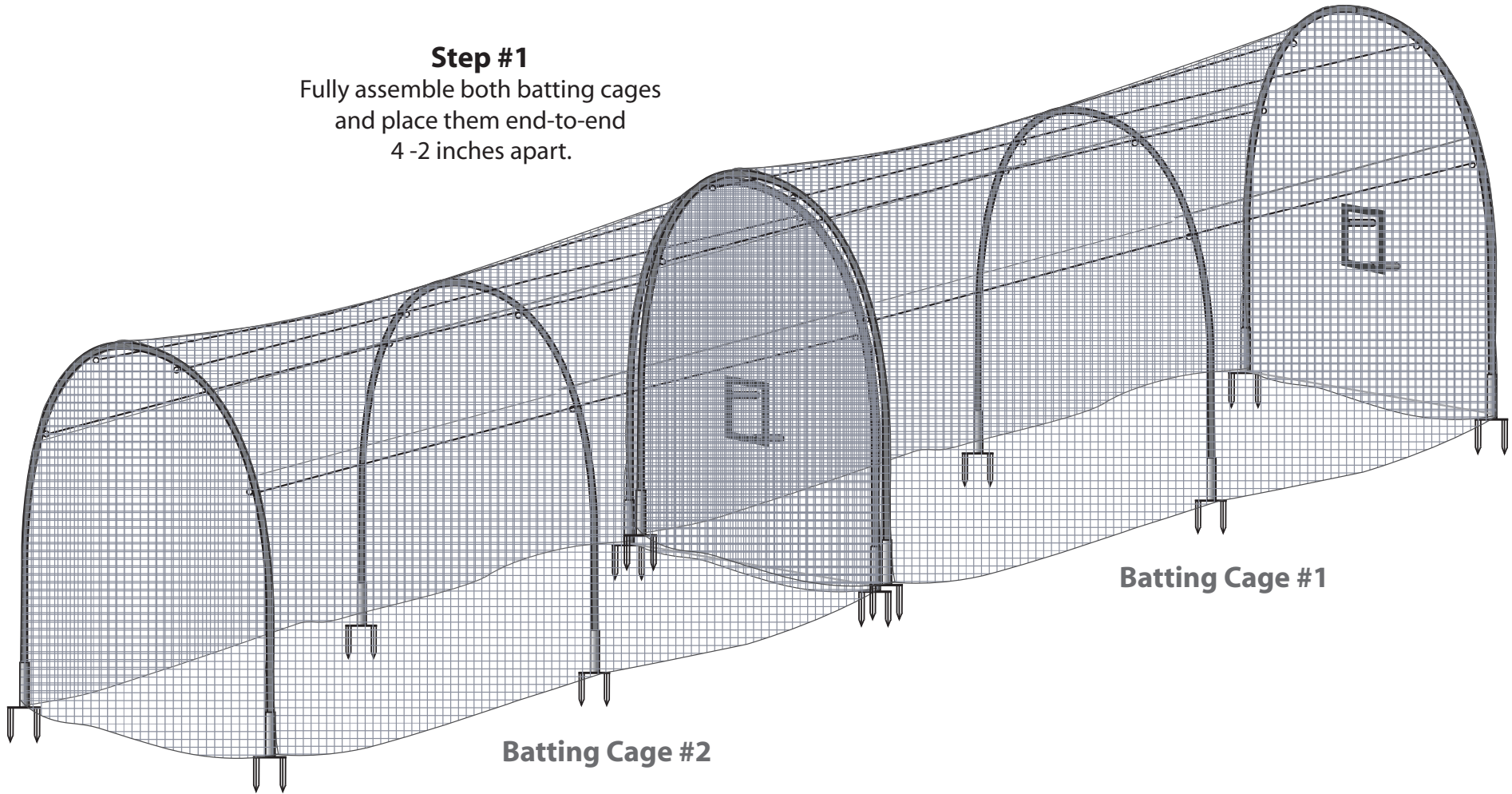

Joining 2 Cages INSTRUCTIONS

Step #2

Match the red reinforced seams together where the cages meet. Using the **extra support ropes** weave the two cages together.

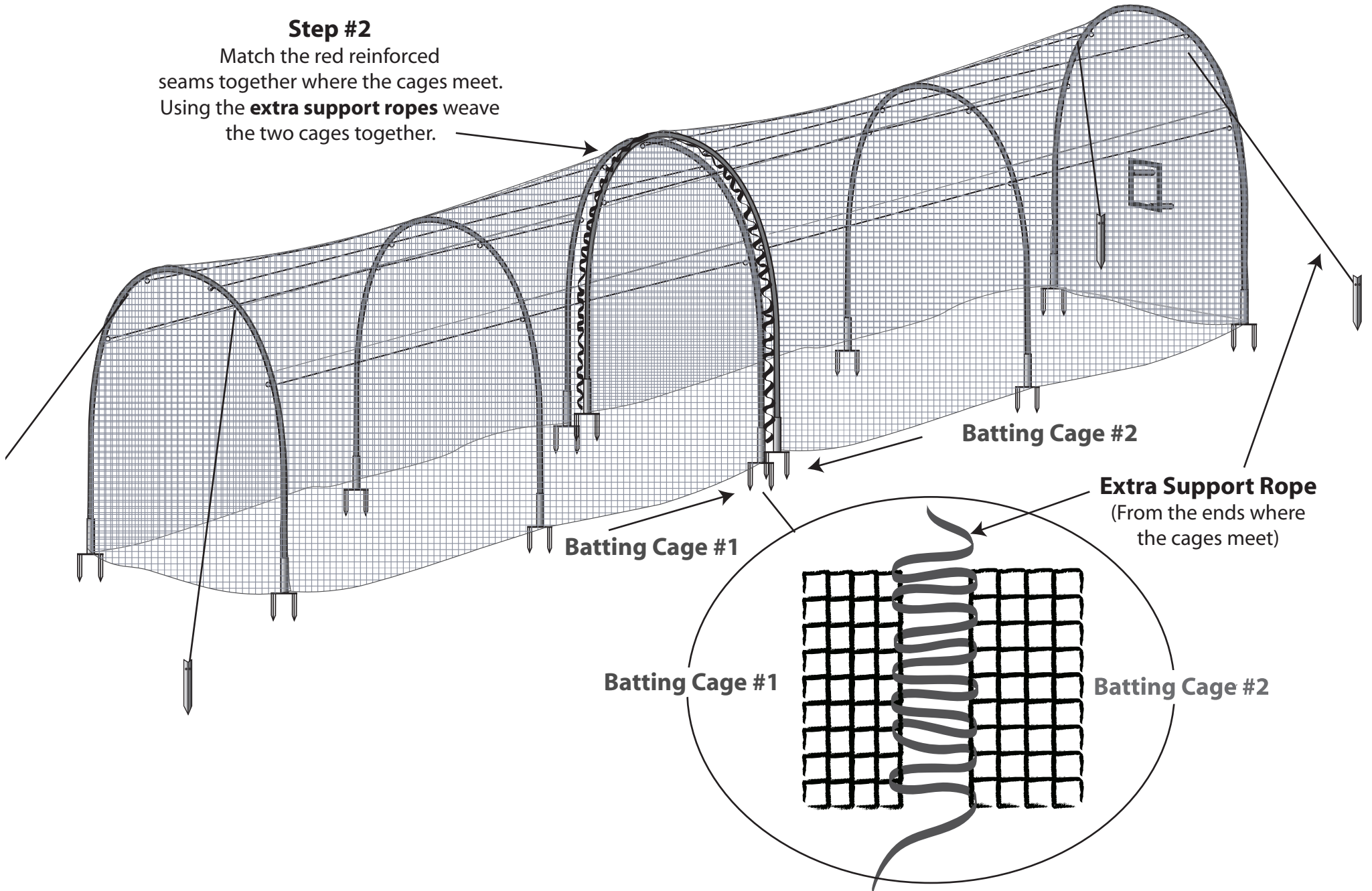

Joining 2 Cages INSTRUCTIONS

Step #3

Using scissors, cut an opening in the netting where the stitched netting come together on both cages.

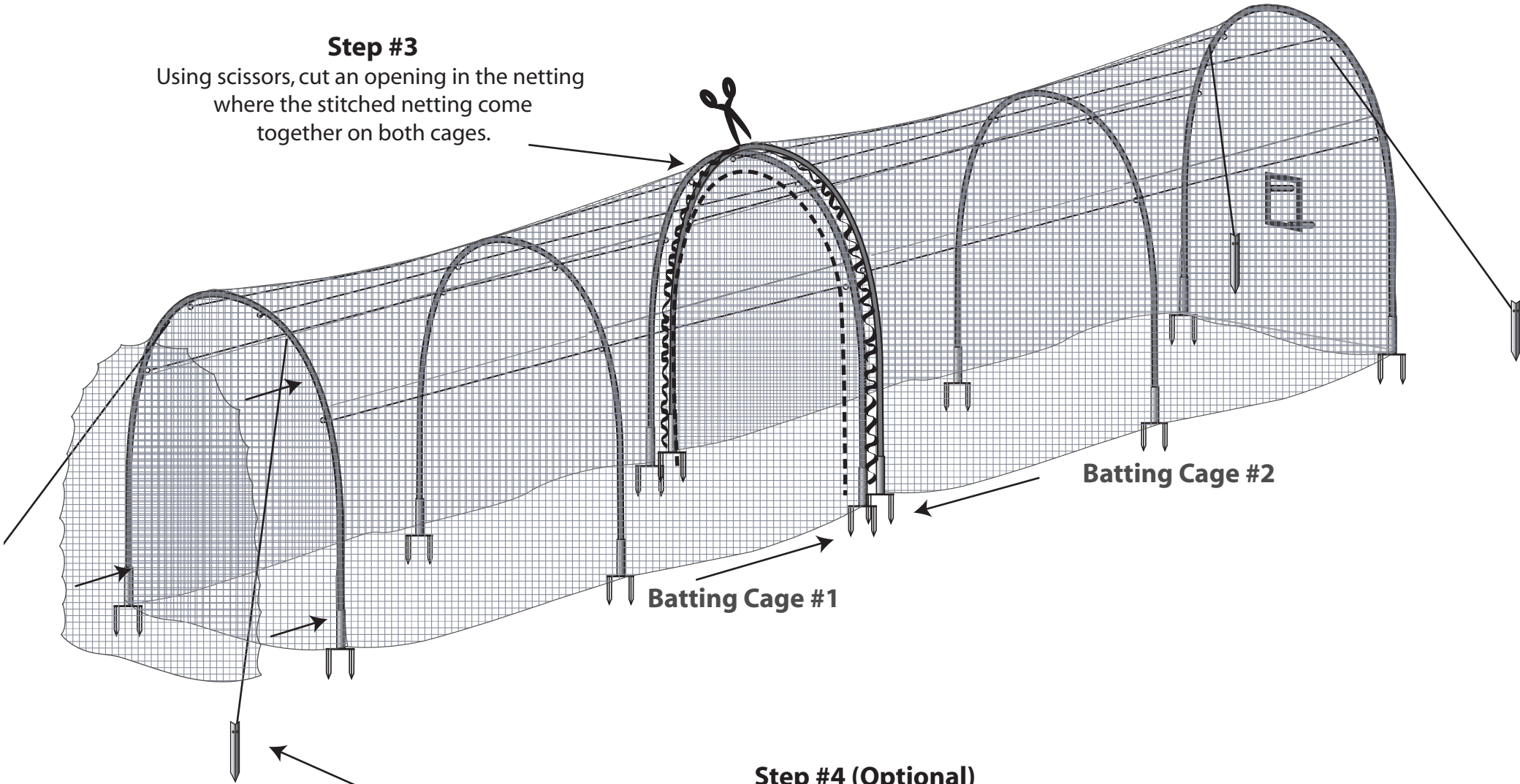

Step #4 (Optional)

After cutting the netting on both cages take the extra netting and attach it to the end of the cage opposite the Pitching Machine Harness. This extra netting will provide additional support and cushioning to the backstop area.