

BSP-44-22

4 PANELS, 2 CENTERS, 2 WING OVERHANGS

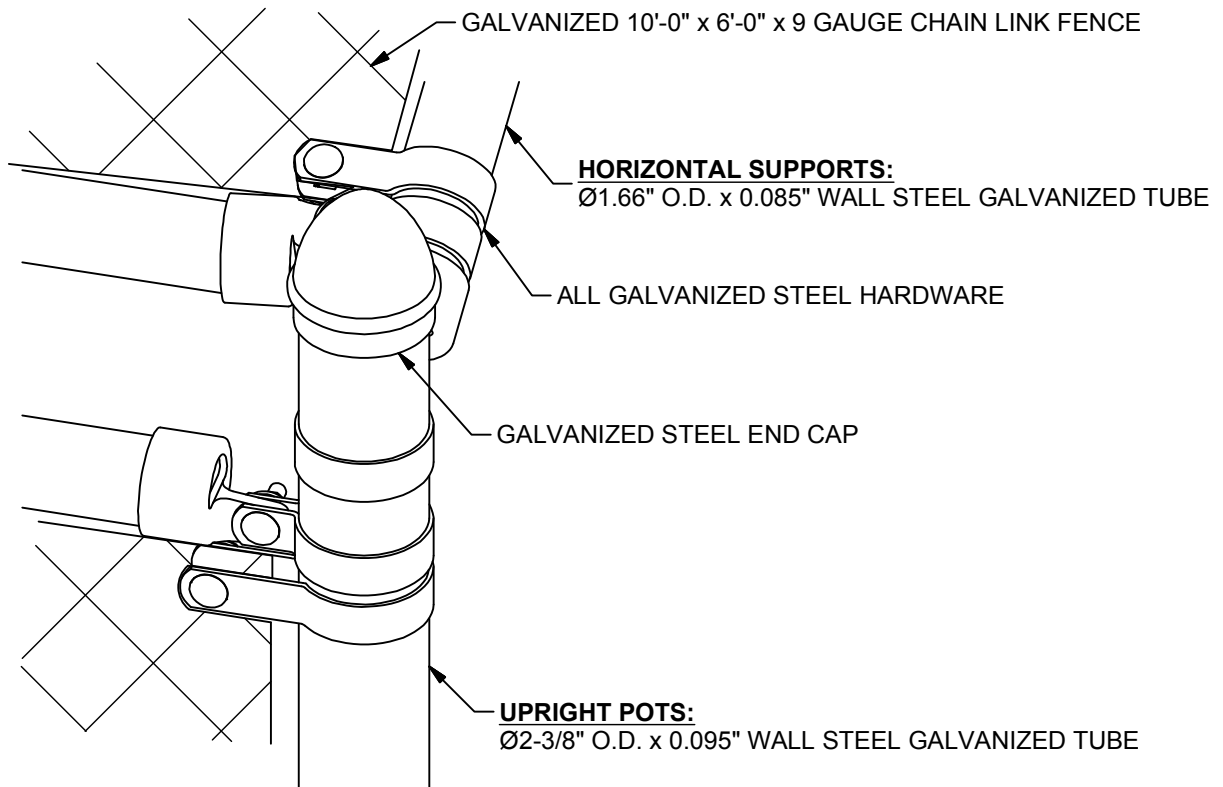

DETAIL A

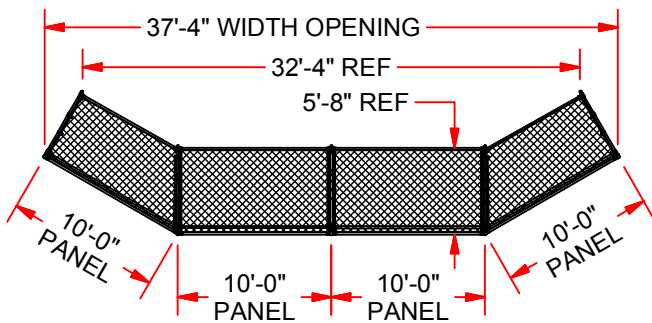

FEATURES:

- * UPRIGHT SECTIONS 10'-0" WIDE x 12' HIGH
- * ALL PANELS GALVANIZED 10'-0" x 6'-0" x 9 GAUGE CHAIN LINK FENCE
- * ALL GALVANIZED STEEL HARDWARE
- * Ø2-3/8" O.D. x 0.095" WALL GALVANIZED STEEL TUBE
- * Ø1-5/8" O.D. x 0.085" WALL GALVANIZED STEEL TUBE
- * SHIPPING WEIGHT 1134 LB / EACH

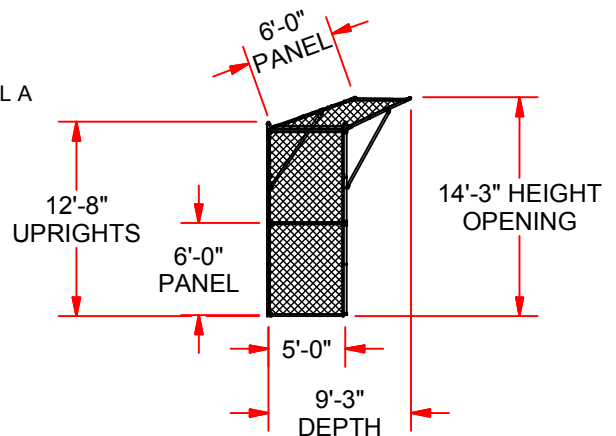
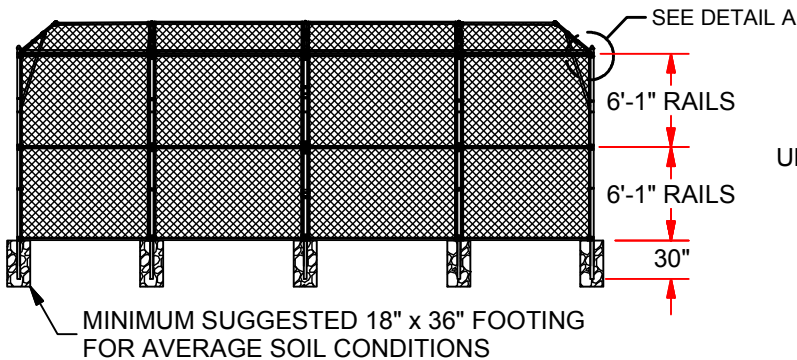

BSP-44-22
4 PANELS, 2 CENTERS, 2 WING OVERHANGS



DRAWING NAME / PART NUMBER: BSP-44-22	
DRAWN BY: Moune T.	ISSUE DATE: 1/30/2013
CHKD BY: WVB	CHK DATE: 1/31/2013
SHEET: 1 OF 1	