

ATTACKII 

ATTACK 

VOLLEYBALL PITCHING MACHINES



ATTACKII™ AND ATTACK™ VOLLEYBALL MACHINE
PATENTS APPLIED FOR

INSTRUCTION MANUAL

OPERATION · SETUP · USE & CARE · SERVICE



SPORTS ATTACK LLC. | 800.717.4251 | www.sportsattack.com

WARRANTY STATEMENT

What is most important to Sports Attack is that your machine meets your expectations of quality and performance. We stand behind the material and workmanship of our machines for five (5) years from the date of original purchase for institutional and residential use and one (1) year for commercial environments, with the following exceptions:

- Throwing Wheels are warranted for two (2) years;
- Electronic Controller is warranted for two (2) years; and,
- Throwing Wheel Motors are warranted for two (2) years.

This warranty excludes any cosmetic issues or normal wear and tear of the unit, and is not in effect if the machine has been misused, misapplied, improperly assembled, or modified without the express written permission of Sports Attack. In addition, this warranty does not apply to damage in transit, in any accident unrelated to the direct operation of the equipment, or by fire, flood or act of God.

If you encounter any issues during the warranty period, Sports Attack will quickly get your machine back in working order. If the warranty repair involves a replacement part, we will make sure you get both the part and easy instructions for replacement at no cost to you. If a service person is needed, Sports Attack will pay the pre-approved labor charge to get your machine back in working order.

EFFECTIVE IMMEDIATELY: Warranty components such as motors, etc. now require a picture of the component when submitting replacement request.

Please know that any problem can quickly be resolved with a phone call to our experienced, responsive customer service department at 800.717.4251. We are here to answer your questions and to make sure your machine provides you years of service.

RETURNS

Sports Attack manufactures the highest quality sports training equipment in the world. If for any reason you are not satisfied, a machine can be returned within 30 days of receipt for any reason for a full refund less a 10% restocking fee. Cost of shipping the unit back to Sports Attack will also be the responsibility of the purchaser. Please note that the refund amount may be reduced by any non-cosmetic damage to the machine.

If you have any questions or concerns, please give our experienced, responsive customer service department a call at 800.717.4251.

SHIPPING DAMAGE CLAIMS PROCEDURE

NOTE: For your protection, please note that equipment in this shipment was carefully inspected and packaged by skilled personnel before leaving the factory.

Upon acceptance of this shipment, the transportation company assumes full responsibility for its safe delivery.

IF SHIPMENT ARRIVES DAMAGED:

1. **VISIBLE LOSS OR DAMAGE:** Be certain that any visible loss or damage is noted on the freight bill or express receipt, and that the note of loss or damage is signed by the delivery person.
2. **FILE CLAIM FOR DAMAGE IMMEDIATELY:** Regardless of the extent of the damage.
3. **CONCEALED LOSS OR DAMAGE:** If damage is unnoticed until the merchandise is unpacked, notify the transportation company or carrier immediately, and file "CONCEALED DAMAGE" claim with them. This must be done within fifteen (15) days from the date the delivery was made to you. Be sure to retain the container for inspection.

Sports Attack, LLC. cannot assume liability for damage or loss incurred in transit. We will, however, at your request, supply you with the necessary documents to support your claim.

To register the Warranty, please go to our website:
sportsattack.com/warranty

For repairs and service after the Warranty period, please call:

Sports Attack
Customer Service Dept.
Ph 800.717.4251
Fx 775.345.2883

RETURNS

To return an item, please contact our Customer Service Department at 800.717.4251.

A 15% restocking fee will be charged for any items accepted for return. It is the customer's responsibility to handle the repacking and shipment (as well as all associated fees) back to Sports Attack.

No returns will be accepted after 30 days of receiving product.

TABLE OF CONTENTS

Warranty Statement	xi
Safety Instructions	4
ATTACK and ATTACKII VOLLEYBALL ASSEMBLY INSTRUCTIONS	
Assembly Instructions	5
Attack Assembly Figures	6
AttackII Assembly Figures	7
Bolt Schedule	8-9
Replacing Throwing Head	10
Operation	11
Shutting Down	12
MAINTENANCE & SERVICE	
Care, Cleaning & Maintenance	13
Component Replacement	
Wheel	14
Motor	14
Controller	15
Increasing Bungee Tension	16
Attack Component Parts	17
AttackII Component Parts	18
Parts List	19-20

INTRODUCTION

Thank You for purchasing this Sports Attack LLC. equipment.

Proper assembly, careful operation and consistent maintenance of this equipment will ensure that it gives you the very best performance and a long, economical service life.

This manual contains the information needed to properly setup the Attack and AttackII, and to use, care for and maintain the Attack and AttackII in a manner which will ensure their optimum performance.

RECEIVING THE PRODUCT

Please check the contents of your boxes to ensure you have received all parts for the machine. If anything is missing or damaged, call Sports Attack Customer Service, 800-717-4251. If the product or package has been damaged in shipping, note on shipping tag, save all evidence of damage along with related documents and contact the shipper immediately.

SAFETY INSTRUCTIONS

ELECTRICAL SAFETY

Use a 115 volt single phase 3-wire grounded power source.

Up to 200 ft. from power source, use a minimum #14/3 grounded 3-wire extension cord.

Over 200 ft. from power source, consult a licensed electrician for required power cord size.

OPTION B 208/220/230V

Green = Earth

White or Blue = Neutral

Black or Brown = Line

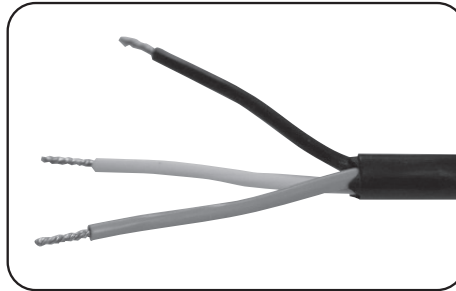
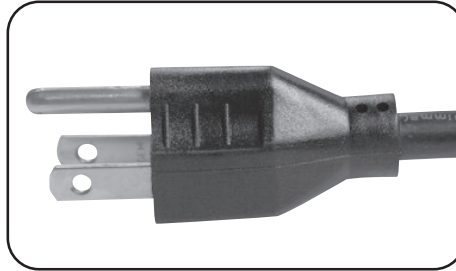

OPERATING SAFETY

1. Never reach hands into throwing wheel area.
2. Always use the Attack or AttackII with throwing wheel shields in place.
3. Use the Attack or AttackII only under adult supervision.
4. Use the Attack or AttackII only for their intended purpose.
5. Do not operate the Attack or AttackII with a damaged cord or plug, if the machine malfunctions or has been damaged.
6. Check machine before turning "ON" to make sure there are no foreign object in feed chute.
7. If ball becomes lodged and stops motor, immediately turn machine off before dislodging.
8. To dislodge ball from throwing wheel, unplug machine and push ball through chute. Do not reach hand into feed chute with the machine running.
9. Only one person at a time should operate the Attack or AttackII.
10. Be sure chain is locked when standing on platform.
11. Do not allow anyone to walk directly in front of the machine. Keep face and hands away from ball exit.
12. A ball should always be test thrown from the Attack or AttackII before beginning any drill. Throw several balls to verify end location.
13. Keep hands, hair and loose clothing away from moving parts.
14. Do not use near water or use damp or wet balls.

WARNING PERSONAL INJURY HAZARD

Carefully read all instructions in this manual, and all labels and warnings on the Attack or AttackII before using either of the machines.

Use machine only under adult supervision. Failure to operate Attack or AttackII as described in this manual can result in severe personal injury or death.

ELECTRICAL SHOCK HAZARD

Attack or AttackII must be connected to a properly grounded electrical receptacle.

Do not operate on wet ground.

WARNING PERSONAL INJURY HAZARD

Keep hands away from throwing wheels anytime the machine is connected to a power source.

Carefully check the Attack or AttackII for completeness and condition before connecting to electrical power.

EQUIPMENT ELECTRICAL DAMAGE

DO NOT plug in or energize the equipment until all Assembly and Operation Instructions are read and followed.

COMPONENT DIAGRAM & PACKING LIST

ATTACK & ATTACKII

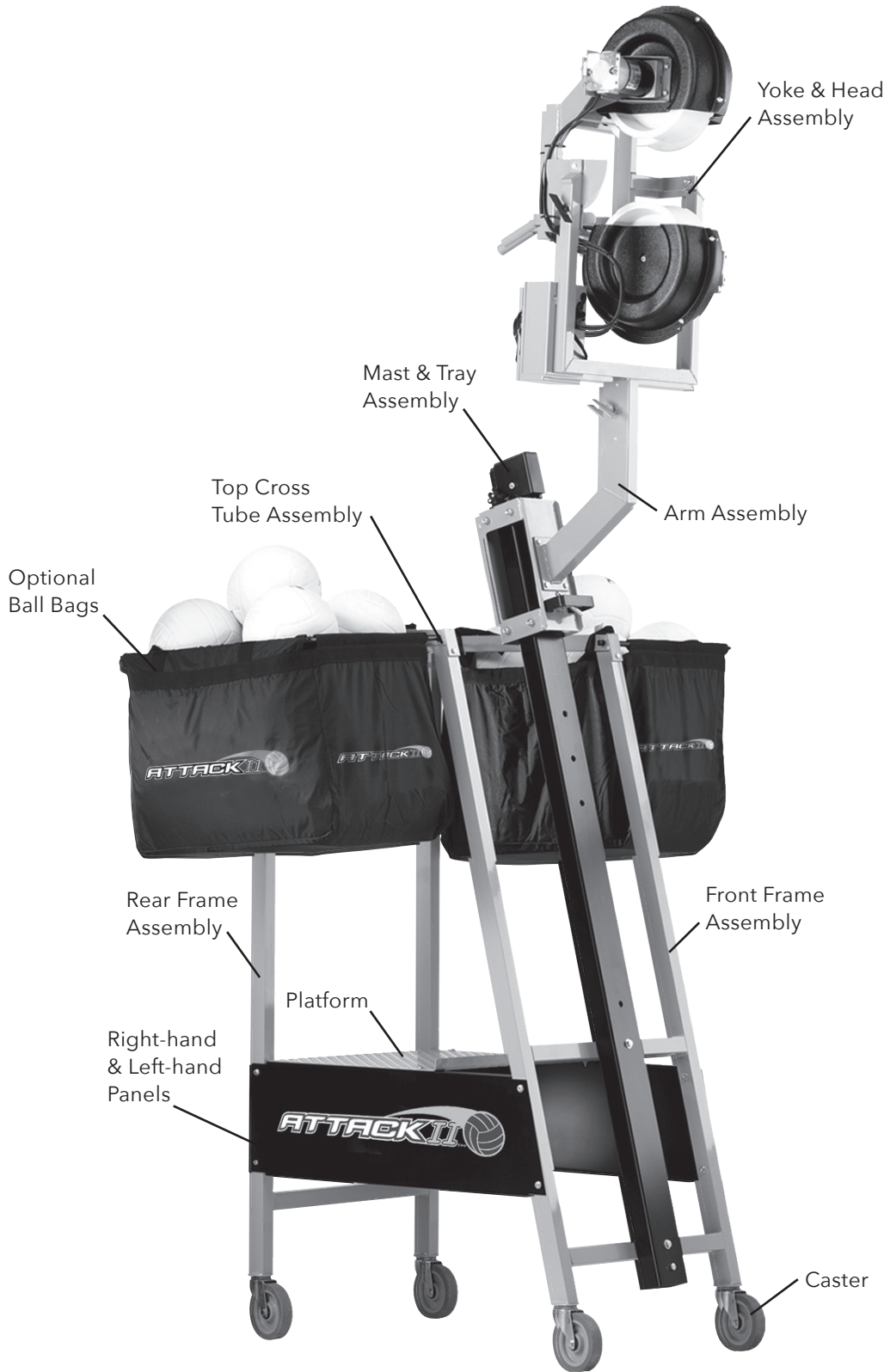

CAUTION PERSONAL INJURY HAZARD

Failure to use the special tool provided to install the casters could result in personal injury.

EQUIPMENT DAMAGE

Failure to use the special tool provided to install the casters could result in equipment damage.

ASSEMBLY PARTS

Qty	Item
1	Yoke & Head Assembly
1	Arm Assembly
1	Mast & Tray Assembly
2	Top Cross Tubes
1	Rear Frame Assembly
1	Front Frame Assembly
1	Platform
1	Right Hand Panel
1	Left Hand Panel
1	Left Hand Panel
1	520-9000 Hardware Kit
1	Ball Bag

HARDWARE KIT Item# 520-9000

Qty	Item
20	1/4" USS Washers
4	1/4" Split Lock Washer
16	1/4" Nylon Nuts w/Flange
8	1/4" - 20 x 3/4" Bolts
8	1/4" - 20 x 2" Bolts
4	1/4" - 20 x 2 1/4" Bolts
4	3/8" USS Washers
2	3/8" Nylon Nuts
2	3/8" - 16 x 4" Bolts
1	Wrench for Casters
2	Casters, 4" Non-locking
2	Casters, 4" Locking

ASSEMBLY INSTRUCTIONS

Tools required: Two $\frac{7}{16}$ " wrenches and two $\frac{9}{16}$ " wrenches or two small crescent wrenches.

STEP ONE

Lay out all parts and check them against the parts list on page 4. Call customer service immediately if any parts are missing. Please have applicable part numbers as shown on parts list.

IMPORTANT: as you assemble the machine, leave bolts very loose. Tighten only after the frame is completely assembled.

STEP TWO

Lay out rear frame assembly, front frame assembly and right- and left-hand panels. Assemble as shown in (Figure 1) using BS1 and BS1A.

STEP THREE

With bolts from Step Two still loose, set platform in place and tighten bolts securely using BS2. Now go back and tighten bolts from Step Two assembly (Figure 2).

STEP FOUR

Screw casters BS3A & BS3 into the bottom of each leg (Figure 4) using wrench provided. TIGHTEN SECURELY.

STEP FIVE

Bolt mast to frame assembly as shown in (Figure 3). Do not tighten bolts until both are in place with the nuts on finger tight. Use bolt arrangement BS4 shown.

STEP SIX

Bolt arm assembly onto rolling tray as shown in (Figure 3). Again do not tighten bolts until all four are in place. Use bolt arrangement BS2 shown.

STEP SEVEN

Loosen side-to-side swivel handle on arm assembly and attach throwing head by inserting shaft into bearing provided in arm assembly and tighten side-to-side swivel handle (Figure 3).

Assembly is now complete and your Attack or Attack II Volleyball Machine is ready for use. See instructions in the manual and on the decals on the machine for operating procedures and options.



Wrench provided (in the nut and bolt kit with casters) to securely tighten casters. See Page 6.

CAUTION PERSONAL INJURY HAZARD

Failure to use the special tool provided to install the casters could result in personal injury.

EQUIPMENT DAMAGE

Failure to use the special tool provided to install the casters could result in equipment damage.

HARDWARE KIT Item# 520-9000

Bolt Ref.	Item
20	$\frac{1}{4}$ " USS Washers
4	$\frac{1}{4}$ " Split Lock Washer
16	$\frac{1}{4}$ " Nylon Nuts w/Flange
BS2	$\frac{1}{4}$ " - 20 x $\frac{3}{4}$ " Bolts
BS1A	$\frac{1}{4}$ " - 20 x 2" Bolts
BS1	$\frac{1}{4}$ " - 20 x 2 $\frac{1}{4}$ " Bolts
4	$\frac{3}{8}$ " USS Washers
2	$\frac{3}{8}$ " Nylon Nuts
BS4	$\frac{3}{8}$ " - 16 x 4" Bolts
BS3	Wrench for Casters
BS3	Castors, 4" Non-locking
BS3A	Castors, 4" Locking

ATTACK & ATTACKII FIGURES IN ASSEMBLY

Figure 1 Using BS1 & BS1A

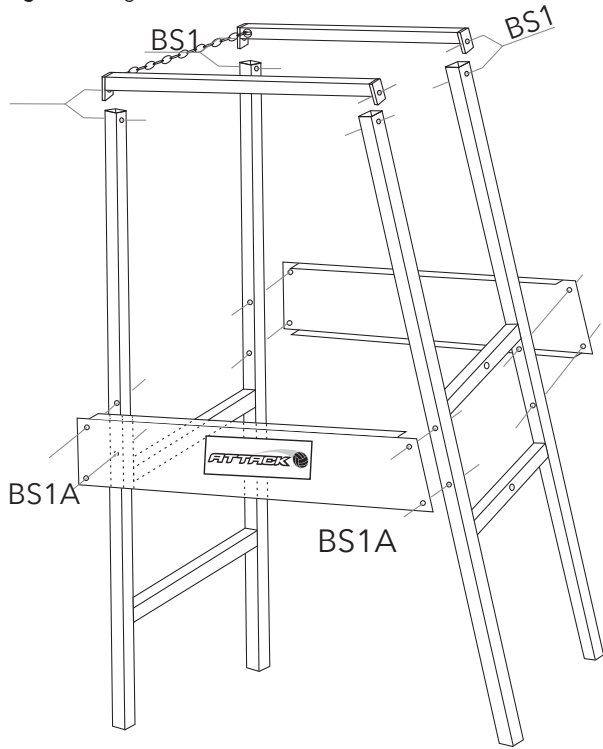

Figure 2 Using BS2

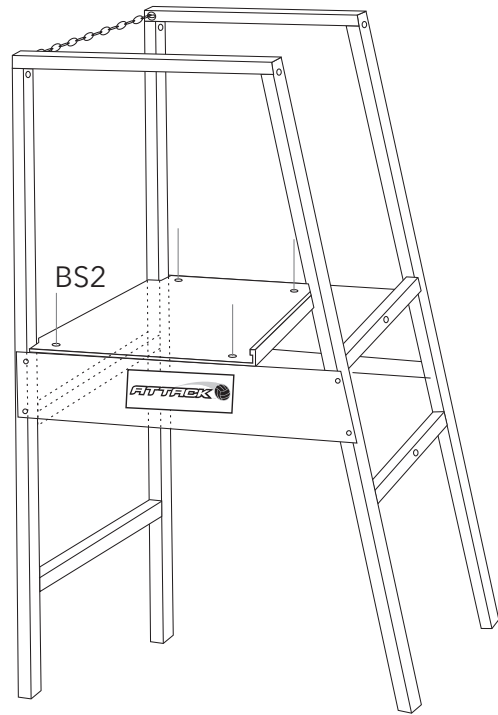

Figure 3 Using BS4 and BS5

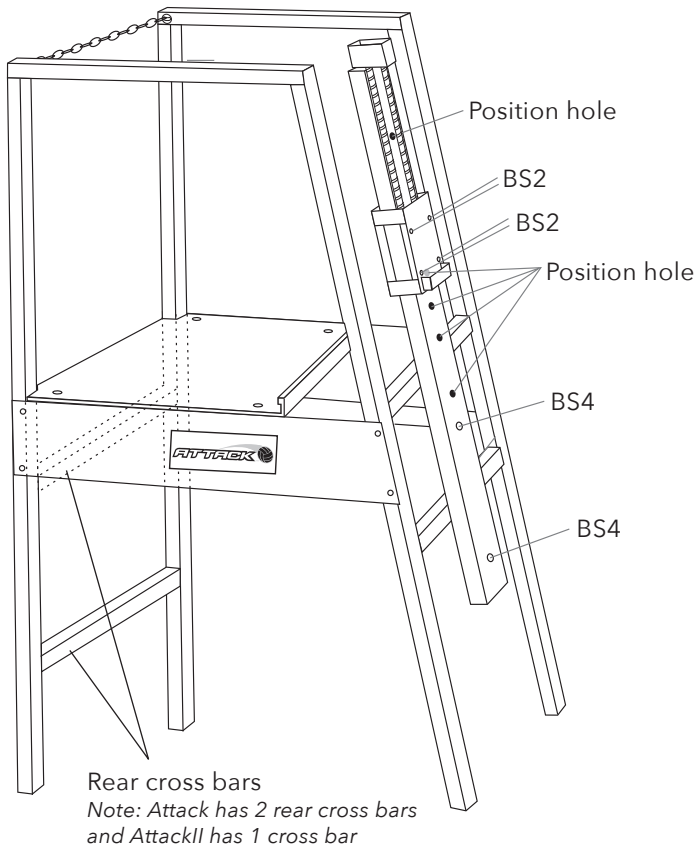
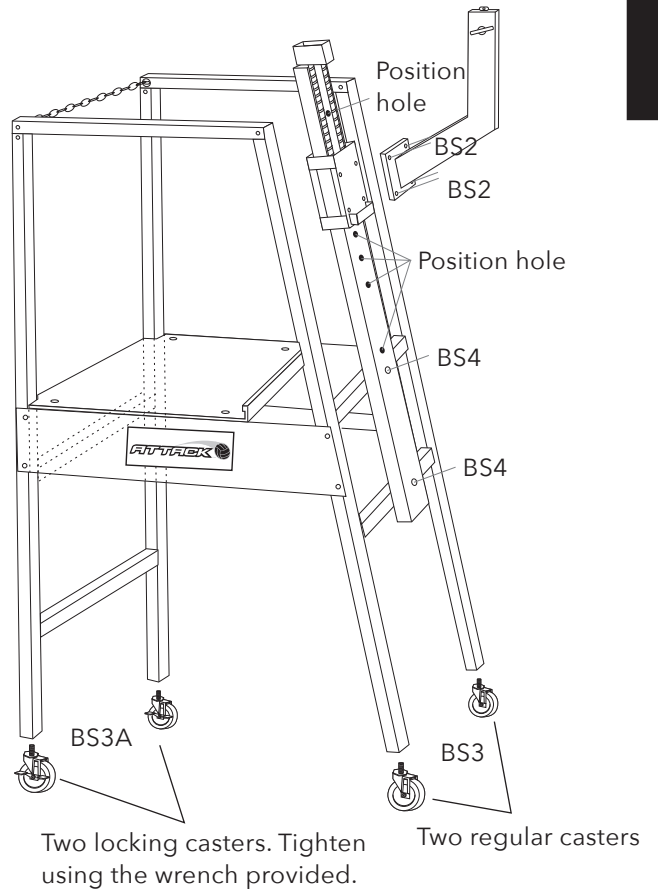
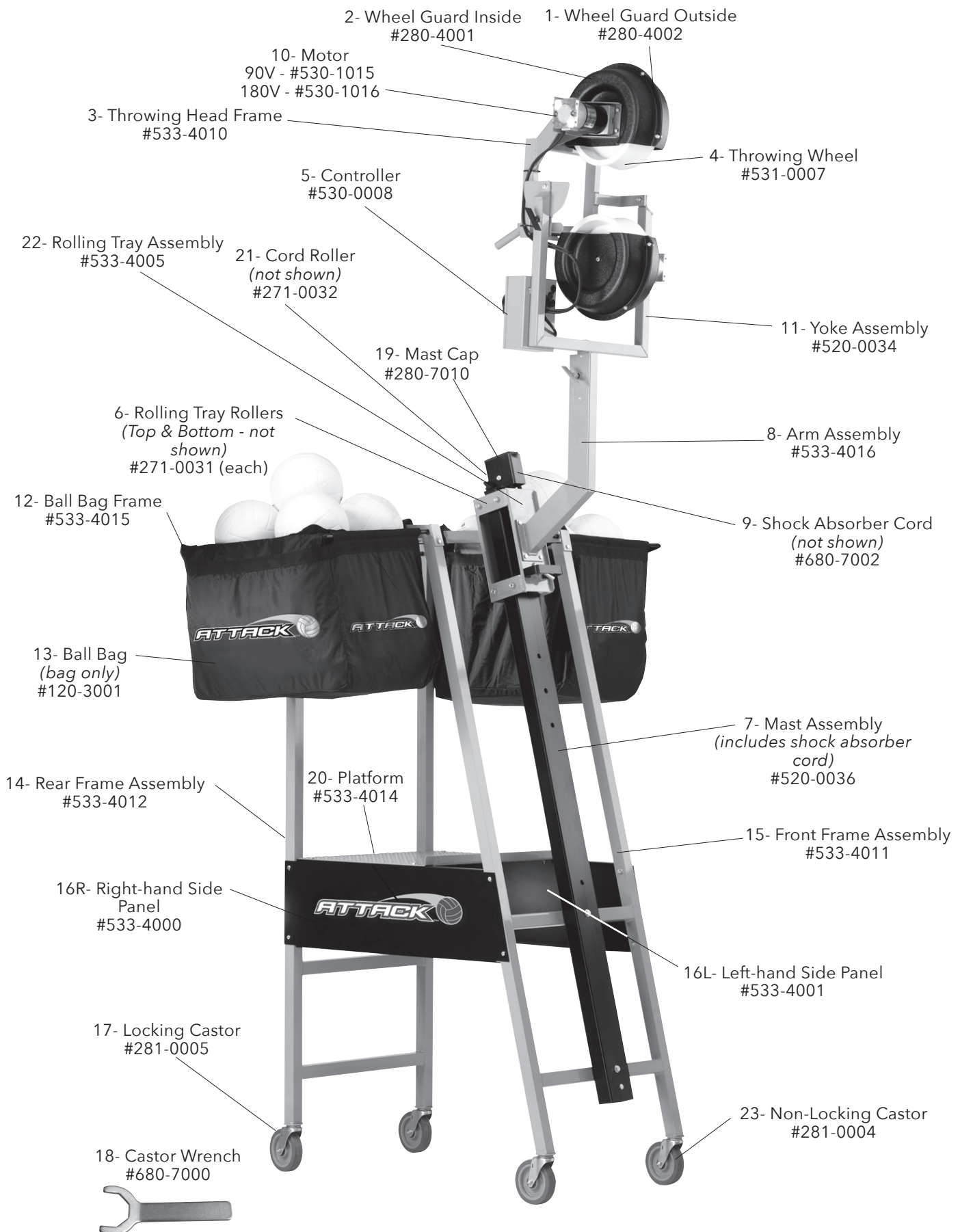

Figure 4 Using BS4, BS3 & BS3A casters



COMPONENT PARTS ATTACK



ATTACK PARTS LIST

ATTACK™

EM	PART NO.	DESCRIPTION	QTY PER
1	A-104	Rear Frame Assembly	1
2	A-105	Front Frame Assembly	1
3	533-4014	Platform	1
4	533-4000	Righthand Panel	1
	533-4001	Lefthand Panel	1
5	533-4013	Top Cross Tube Assembly	2
6	281-0004	Caster, non-locking	2
	281-0005	Caster, locking	2
7	531-3006	Arm Assembly	1
8	533-4002	Yoke (Universal)	1
9	520-9000	Hardware Kit	1
10	A-1A	Caster Wrench	1
11	210-0003	Motor	2
12	280-0006	Throwing Wheel	2
13	223-0009	Controller	1
14	A-116	Head Assembly (Universal)	1

OPTIONAL ACCESSORIES

EM	PART NO.	DESCRIPTION	QTY PER
	120-3000	Ball Bag Kit (bag and frame)	1
	120-3001	Ball Bag (only)	1
	533-4015	Ball Bag Frame (only)	1
	120-3002	Machine Cover	1

To order additional parts,
please contact:

**Sports Attack
Customer Service Dept.**

Ph 800.717.4251

Fx 775.345.2883

Attack Parts List

COMPONENT PARTS ATTACKII

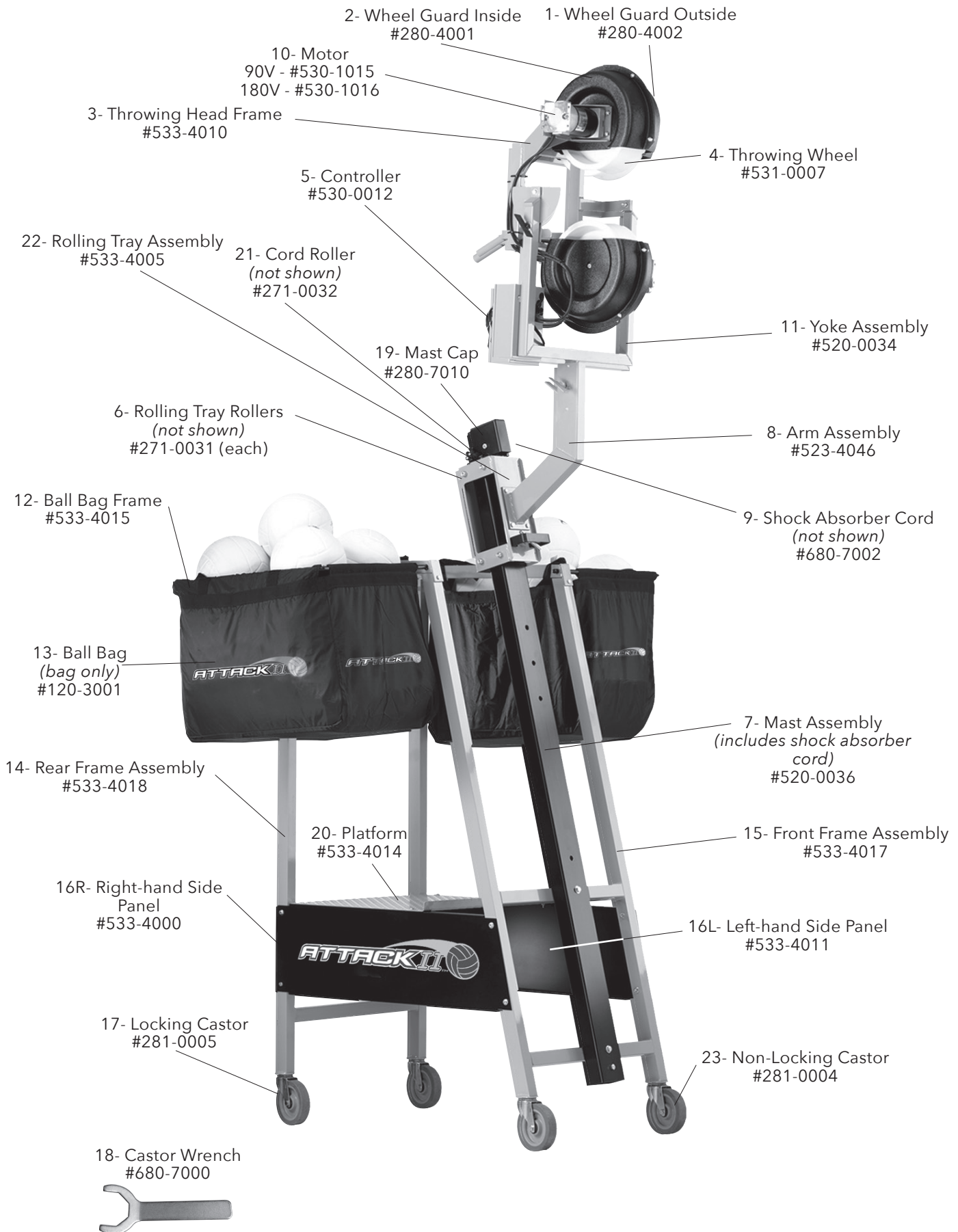

ATTACK II PARTS LIST

ATTACKII™

EM	PART NO.	DESCRIPTION	QTY PER
1	A2-103	Rear Frame Assembly	1
2	A2-105	Front Frame Assembly	1
3	A2-9	Platform	1
4	533-4000	Righthand Panel	1
	533-4001	Lefthand Panel	1
5	A2-102	Top Cross Tube Assembly	2
6	281-0004	Caster, non-locking	2
	281-0005	Caster, locking	2
8	A2-112	Arm Assembly	1
9	A2-101	Yoke (Universal)	1
10	520-9000	Hardware Kit	1
11	A2-1A	Caster Wrench	1
12	A2-44	Motor	2
13	A2-2U	Throwing Wheel	2
14	A2-32C	Controller	1
15	A2-116	Head Assembly (Universal)	1
16	A2-107	Mast Assembly (Universal)	1
17	A2-115	Tray Assembly (Universal)	1

OPTIONAL ACCESSORIES

EM	PART NO.	DESCRIPTION	QTY PER
	120-3000	Ball Bag Kit (bag and frame)	1
	120-3001	Ball Bag (only)	1
	533-4015	Ball Bag Frame (only)	1
	120-3002	Machine Cover	1

To order additional parts,
please contact:

**Sports Attack
Customer Service Dept.**

Ph 800.717.4251

Fx 775.345.2883

REPLACING THROWING HEAD ATTACK and ATTACK II

STEPS IN REPLACING THE THROWING HEAD

1. Lower throwing head to the lowest position on the mast & tray assembly. This is the "setting and transport" position.
2. Loosen side-to-side swivel handle on arm assembly.
3. Lift old throwing head assembly until it is free from the arm assembly and set aside.
4. Lift new throwing head and insert into the bearing provided in the arm assembly, with the throwing wheels facing away from the mast and tray assembly. Tighten swivel handle.



Throwing Head Assembly

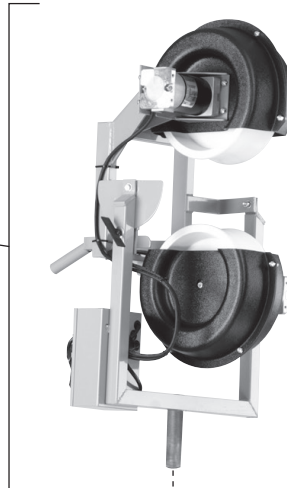

INSTALLING A BALL BAG



Step 1 Insert one arm of the ball bag frame into the appropriate holes on the platform frame.



Step 2 Carefully apply firm pressure to bend the other arm so that it lines up with the corresponding holes on the platform frame.



Step 3 Insert arm of ball bag frame into the holes on the platform frame.

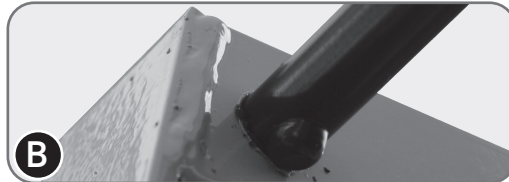

Step 4
A Use your palm to "whack" the ball bag frame.
B Button will rest against frame.



Step 5 Both arms are securely in place.



Step 6 Tie ball bag straps.

INSTALLING A BALL BAG

STEP 1

Insert one arm of the ball bag frame into the appropriate holes on the the platform frame. The second arm of the ball bag frame will not line up with the set of corresponding holes on the platform frame. This is intentional.

STEP 2

Holding on to the platform frame as shown in the photo for Step 2, carefully apply firm pressure on the second arm and bend it until it lines up with the corresponding holes in the platform frame.

STEP 3

Insert arm into the corresponding holes on the platform frame.

STEP 4 A & B

Still holding on to the platform frame with one hand, use the palm of your other hand to "whack" the frame (photo A) until the button rests against the frame (photo B).

STEP 5

Both arms are now securely in place with the proper amount of tension to keep ball bag in place.

STEP 6

You may now tie the ball bag straps to the platform frame.

To order additional parts, like a ballbag, please contact:

**Sports Attack
Customer Service Dept.**

Ph 800.717.4251

Fx 775.345.2883

VOLLEYBALL OPERATION

The Attack or AttackII is a total practice machine. No special training other than the complete, careful reading of this manual is required to operate the machine. Many coaches have broadened and refined their own coaching skills by its use.

ELEVATING AND LOWERING THE MACHINE HEAD

1. Release the locating pin on the sliding tray.
2. Position the throwing head into one of five elevation settings to the required height.
3. Locating pin will snap into place.

INCREASE OR DECREASE SPEED

1. Before turning machine "ON," turn dials located on the throwing head to the "0" position.
2. Turn on/off switch to "ON." The wheels will spin slowly. Turn speed control knobs clockwise to increase speed.
3. Turn the speed control knobs counter-clockwise to decrease speed.

BALL SPIN, BREAK OR MOVEMENT

1. **Floater:** Both knobs turned to the same setting, making the wheels spin at the same RPM.
2. **Top Spin:** Upper wheel turning fast, lower wheel turning slowly. Variations of the ball spin and break are determined by the wheel speeds.

HORIZONTAL CONTROL

1. Loosen to vary direction.
2. Tighten for repeatability.

VOLLEYBALL SHUTTING DOWN

TURNING ATTACK "OFF"

1. Set each speed control dial to "0."
2. Turn the on/off switch "OFF."
3. Unplug Attack or AttackII from the power source.

TRANSPORTING

1. Turn the machine "OFF" and unplug.
2. Lower throwing head to the lowest position on the sliding tray. The locating pin will snap into place.

DO NOT STORE OR TRANSPORT WITH THROWING HEAD ELEVATED.

CARE, CLEANING & MAINTENANCE

LUBRICATION

Throwing Wheel Motors

Motors are sealed and require no lubrication.

CLEANING THE THROWING WHEELS

The throwing wheels must be kept clean to maintain accuracy. Clean the wheels periodically to control the build-up of dirt.

1. Turn the on/off switch "OFF" and allow the wheels to come to a complete stop.
Unplug machine from electric power.

Dampen a rag with soap and water. Turn the throwing wheel by hand and scrub the wheel until the build-up is removed. For very heavy build-up, a synthetic scouring pad, such as a Scotch-Brite® scouring pad, or medium sandpaper may be used sparingly. Methyl Ethyl Ketone (M.E.K.) may be required to help loosen the build-up of dirt or ball residue.

EXAMINE THE MACHINE

Examine Attack or AttackII for condition and completeness before every use:

1. Throwing wheels must be tight on the motor shafts. Check that the keyway retaining bolts are tight.
2. Wheel guard must be securely fastened to the throwing head.
3. Check rolling casters once a year for tightness. Tighten bolts securely using wrench provided, but do not over-tighten. See Page 8, Schedule 3.
4. Check all casters and bolts of frame once a year for tightness.

CAUTION PERSONAL INJURY HAZARD

Never attempt to clean the throwing wheels while they are turning. Rags or implements caught in spinning wheels can cause serious injury.

Unplug machine before cleaning the wheels or performing any kind of service.

CHEMICAL HAZARD

Methyl Ethyl Ketone (M.E.K)

Read and follow the directions and safety instructions on the M.E.K container.

FIRE HAZARD

Methyl Ethyl Ketone (M.E.K)

M.E.K. is flammable. Do not use M.E.K. around a fire or flame. Do not use M.E.K. near a running generator or other source of ignition.

COMPONENT REPLACEMENT

THROWING WHEEL REPLACEMENT

1. Turn the throwing wheels "OFF" and unplug the power cord. Remove four bolts holding the wheel guard to the motor-side wheel guard.
2. Hold the wheel so that it cannot move. Turn the keyway retaining bolt counter-clockwise using a box end wrench (See Figure 9).
SUGGESTION: If the bolt is too tight, give the opposite end of the wrench a series of light taps with a hammer making sure the wrench remains on the bolt.
3. Remove the bolt and washers.
4. Work the wheel off of the motor shaft. Be sure to catch the key as it is freed from the keyway.
5. Ball throwing wheels are machine balanced. Small holes in the side of the wheel are applied at the factory and are normal. A slight wobble is also normal.

Reassemble in reverse order.

- a. Install wheel to motor shaft with key slots aligned.
- b. Be sure the key is in place, and inserted so that it is flush with the boss at the wheel center.
- c. Be sure the washer and lock washer are installed in the right order, and that the keyway retaining bolt is tightened.
- d. Test the wheel by spinning it by hand and making sure that it spins freely before turning the unit "ON".
- e. Be sure the wheel guard is properly and securely reinstalled.

NOTE: Check bolts for tightness once a season. Tighten bolts securely, but do not over-tighten.

MOTOR REPLACEMENT

1. Turn the on/off switch "OFF" and unplug the power cord.
2. Remove the throwing wheel (see above) and two wheel guards.
3. Remove four screws holding controller into main electrical box. Note the position of the motor wires on the controller, then disconnect the wires. See Page 14.
4. Note the routing of the motor wires. Loosen any wire clamps.
5. Remove bolts holding the motor to the main frame.

Reassemble in reverse order.

NOTE: Check bolts for tightness once a season. Tighten bolts securely, but do not over-tighten.



Figure 9 Hold wheel while loosening bolts.

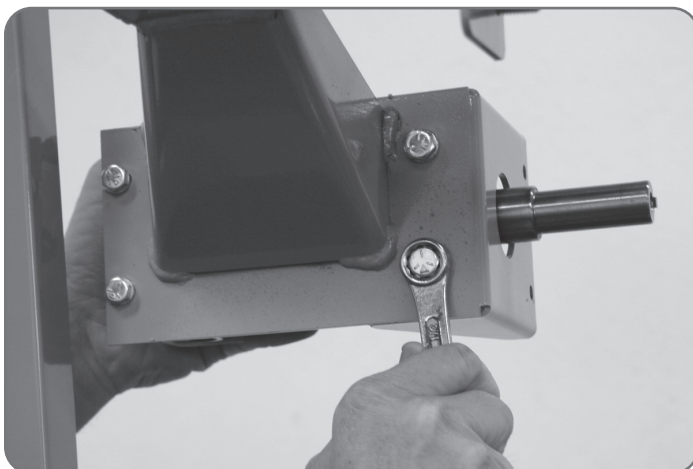
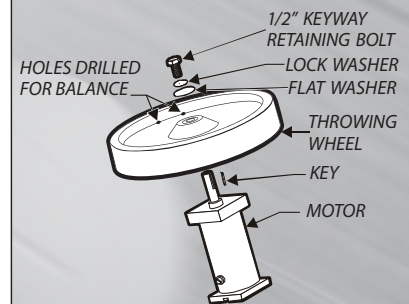

Figure 10 Shown using a 6" 1/2" wrench.



Figure 11 Shown using a 1 1/2" wrench.

COMPONENT REPLACEMENT (cont'd)

CONTROLLER REPLACEMENT

1. Turn the on/off switch "OFF" and unplug the power cord.
2. Remove the four screws holding controller faceplate. Note the position of the main power and motor wires on the controller, then disconnect the wires.

Reassemble in reverse order.

- a. Be sure wires are correctly reinstalled. Motor wire connectors are different sizes. Be sure they are installed on the correct size terminal.
- b. When attaching the knobs, turn the speed control shafts fully counter-clockwise, then install the knobs with the pointer to "0."

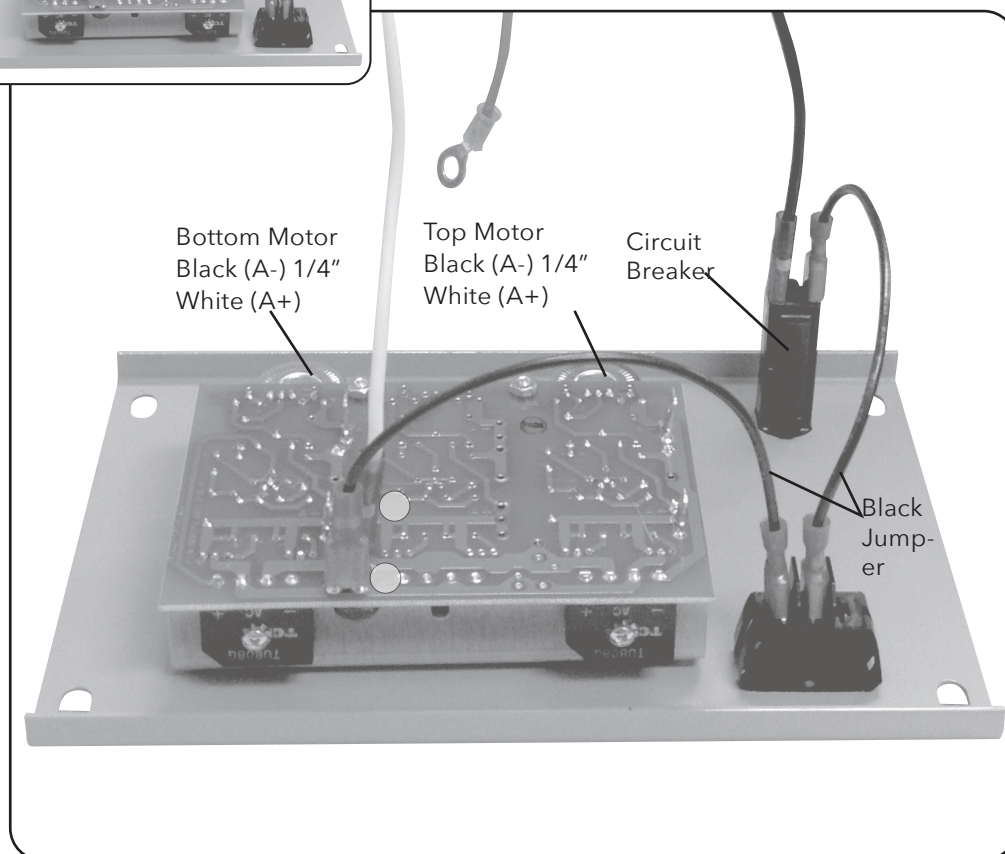
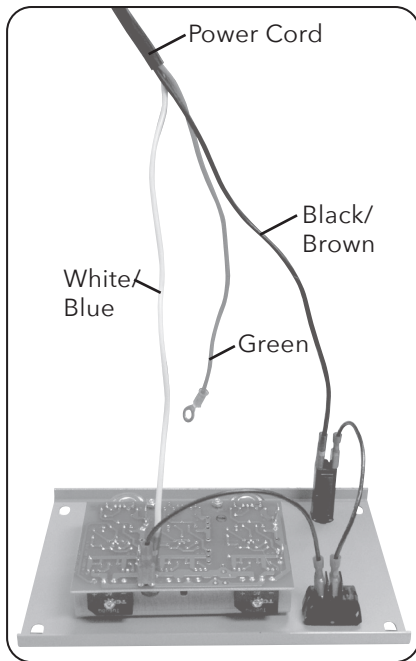

WIRING

POWER CORD

White or Blue Wire (1)

To middle male terminal marked "N."

Black or Brown Wire (2)

To circuit breaker.

Green Wire (3)

Grounds to machine/motor.

MOTOR WIRE LEADS

White 3/16" wide connectors.

Black 1/4" wide connectors.

Black Wire (2) connects to A- on circuit board.

White Wire (2) connects to A+ on circuit board.

CONTROLLER

Black Wire (2)

2 PR jumper wire:

- 1 from on/off switch to circuit breaker
- 1 from on/off switch to circuit board terminal "L".

INCREASING TENSION INSTRUCTIONS

STEPS IN INCREASING TENSION ON THROWING HEAD (LOCATED AT A)

1. Stretch cord approximately 12" (this distance can be adjusted as required)
2. Using vise grips as shown, clamp tightly to hold shock absorber cord.
3. Loosen knot and slide it down to top of vise grips.
4. Repeat process on opposite side.

