

— Instruction Manual —
BNF0701B / BNF1501B / BNF2101B



7 1/2' / 15' & 21' Fixed Player Bench

Aluminum or Powdercoated Steel Frame Assembly

Customer Service
(800) 247-7668

PARTS LIST									
Item	7 1/2' Qty	15' Qty	21' Qty	Description	Item	7 1/2' Qty	15' Qty	21' Qty	Description
A	2	2	2	Aluminum Seat	F	4	6	8	Plastic Tube Plug
B	2	3	4	Leg Assembly	G	4	4	4	Seat End Cap
C	8	12	16	3/8-16 x 3" Carriage Bolt	H	8	8	8	#10 X 3/4" Sheet Metal Screw
D	8	12	16	3/8" Lock Washer	I	8	12	16	3/8" Hex Nut
E	8	12	16	Bench Clamp					

- ◆ Inspect all contents prior to installation. Report any missing parts to dealer immediately.
- ◆ Read all instructions before proceeding.

If Your Bench Is 7 1/2' In Length

1. Attach the *Leg Assemblies* (B) to the 7 1/2' *Aluminum Seat* (A) with 3/8" x 3" *Carriage Bolts* (C), 3/8" *Lock Washers* (D), 3/8" *Hex Nuts* (I) and *Bench Clamps* (E). *Leg Assemblies* (B) should be placed 12" from each end. See Figures 1 and 2.
2. Insert the *Plastic Tube Plugs* (F) into *Leg Assemblies* (B). See Figure 1.
3. Install *Seat End Caps* (G) using #10 x 3/4" *Sheet Metal Screws* (H). See Figure 5.
4. Locate and dig two 8" diameter holes 30" deep and 66" apart from center to center. See Figure 2.
5. Fill the holes with wet premixed concrete. Insert the bench assembly assuring that the seat is level and it is 18" from the ground.

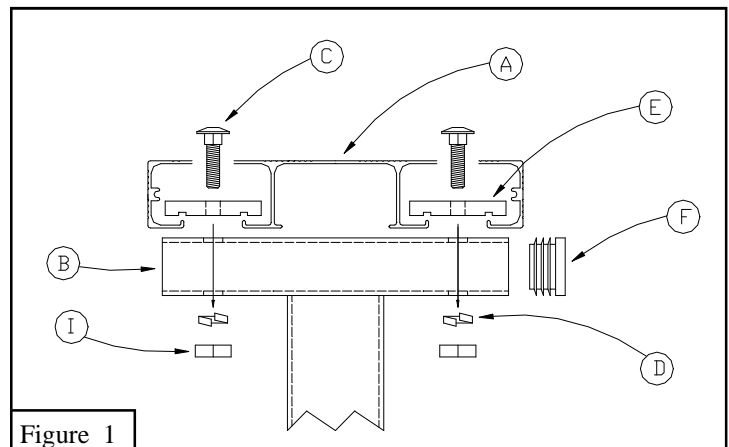

Figure 1

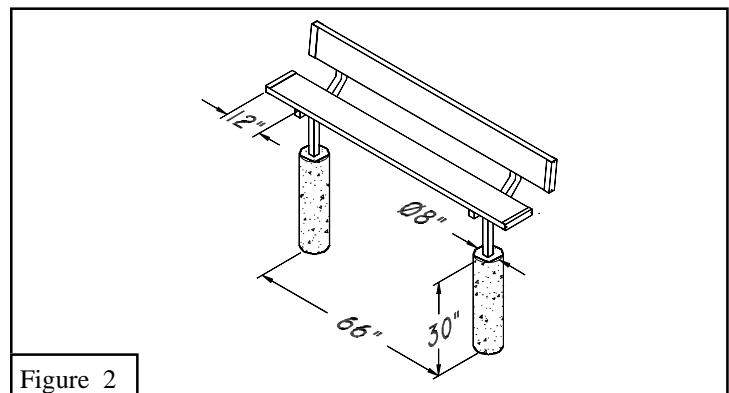

Figure 2

Warning!

The center of the holes should be a minimum of 18" from any wall, fence, or permanent structure.

Note:

It is recommended that the seat be supported until the concrete is set so that it remains perpendicular and level. **Do Not** use the bench for 7 days or until the concrete is fully cured.

If Your Bench Is 15' In Length

1. Attach the *Leg Assemblies (B)* to the *15' Aluminum Seat (A)* with *3/8" x 3" Carriage Bolts (C)*, *3/8" Lock Washers (D)*, *3/8 Hex Nuts (I)* and *Bench Clamps (E)*. Place the first *Leg Assembly (B)* in the center of the *15' Aluminum Seat (A)*. The remaining *Leg Assemblies (B)* should be placed 18" from each end. See Figures 1 and 3.
2. Insert the *Plastic Tube Plugs (F)* into *Leg Assemblies (B)*. See Figure 1.
3. Install *Seat End Caps (G)* using *#10 x 3/4" Sheet Metal Screws (H)*. See Figure 5.
4. Locate and dig three 8" diameter holes 30" deep and 72" apart from center to center. See Figure 3.
5. Fill the holes with wet premixed concrete. Insert the bench assembly assuring that the seat is level and it is 18" from the ground.

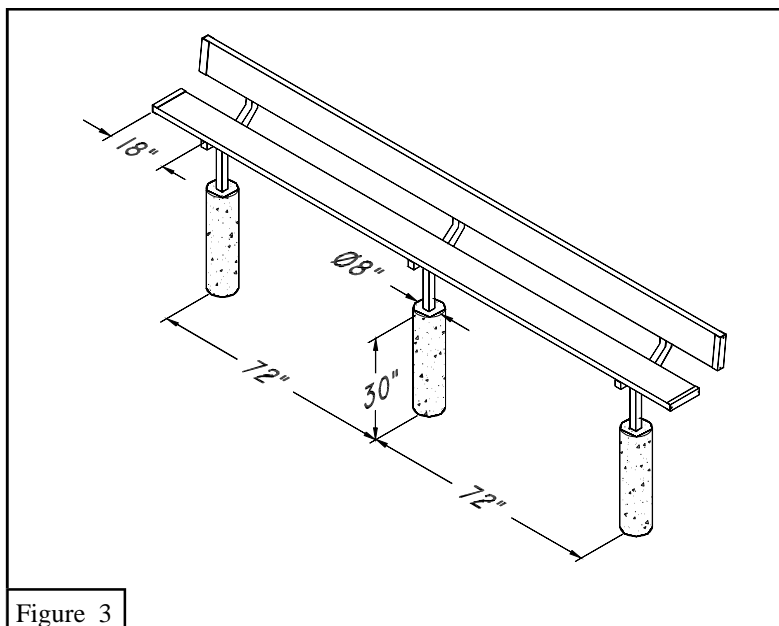

Figure 3

If Your Bench Is 21' In Length

1. Attach the *Leg Assemblies (B)* to the *21' Aluminum Seat (A)* with *3/8" x 3" Carriage Bolts (C)*, *3/8" Lock Washers (D)*, *3/8 Hex Nuts (I)* and *Bench Clamps (E)*. Place one *Leg Assembly (B)* 18" from each end. Position the remaining two *Leg Assemblies (B)* 72" from outside *Leg Assembly (B)* as shown. See Figures 1 and 4.
2. Insert the *Plastic Tube Plugs (F)* into *Leg Assemblies (B)*. See Figure 1.
3. Install *Seat End Caps (G)* using *#10 x 3/4" Sheet Metal Screws (H)*. See Figure 5.
4. Locate and dig four 8" diameter holes 30" deep and 72" apart from center to center. See Figure 4.
5. Fill the holes with wet premixed concrete. Insert the bench assembly assuring that the seat is level and it is 18" from the ground.

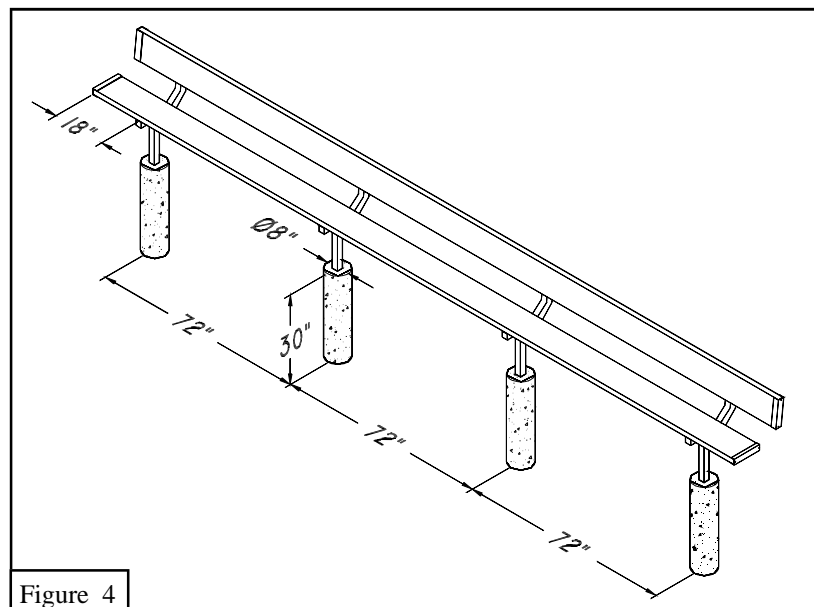

Figure 4

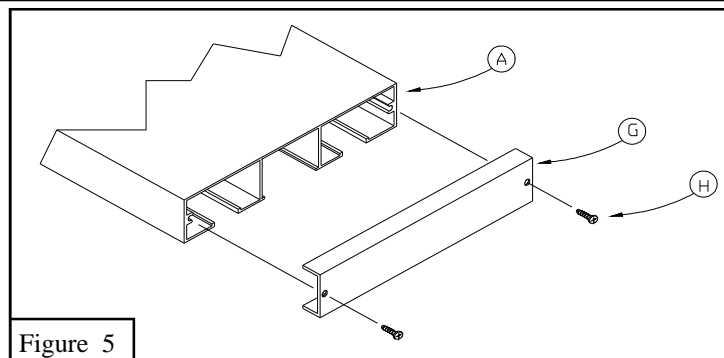

Figure 5

Warning!

The center of the holes should be a minimum of 18" from any wall, fence, or permanent structure.

Note:

It is recommended that the seat be supported until the concrete is set so that it remains perpendicular and level. **Do Not** use the bench for 7 days or until the concrete is fully cured.