

# Read This Before Operating The Heater Softball

## IMPORTANT OPERATING INSTRUCTIONS

**THE HEATER 12" SOFTBALL PITCHING MACHINE THROWS REAL REGULATION BALLS; HOWEVER, THE ACCURACY OF THE HEATER DEPENDS ON THE QUALITY, HARDNESS AND TYPE OF BALLS YOU USE IN THIS MACHINE!**

**HEATER SPORTS RECOMMENDS** USING HEATER 12" PITCHING MACHINE SOFTBALLS IN THE HEATER SOFTBALL MACHINE. THESE BALLS HAVE BEEN PRECISELY CRAFTED TO PROVIDE YOU WITH HOURS OF ACCURATE, TROUBLE FREE BATTING AND FIELDING PRACTICE.

### Heater 12" Softball Pitching Machine Balls

**Heater 12" Softball Pitching Machine Balls are recommended for use with the Heater Softball Machine.** These balls are incredibly accurate, long lasting, and produce the fastest ball speed.

### Regulation 12" Leather Balls:

The Heater Softball Pitching Machine works well with real leather 12" softballs; however, accuracy will vary more than with pitching machine balls because the seams on leather softballs cause the machine to pinch the ball differently on each pitch. Be sure and use real leather balls. Batters should be aware at all times.

## **KNOWN PROBLEMS WITH SIMULATED (SYNTHETIC) LEATHER COVERED BALLS . . .**

### Simulated (synthetic) leather balls:

Simulated leather balls are inexpensive seamed balls that don't work well in the Heater Softball Machine. During operation, portions of the simulated leather cover comes off the ball and attaches to the wheel of the Heater. Also, during operation, consumers have reported seeing small puffs of smoke coming out of the Heater Softball Machine. These puffs are not smoke, but actual pieces of the simulated leather ball being turned into small dust particles as they pitch out of the Heater 12" Softball Pitching Machine.

**IF BALLS GET WET, THEY WILL NOT PITCH PROPERLY UNTIL THEY DRY.**

## **KNOWN FACTS ABOUT DIFFERENT BALLS:**

The speed and accuracy of each pitch is dependent on the hardness, roundness, and type of each ball used.

For example: If you have 12 balls and four are softer than the others (these balls will throw lower than the other balls), if four are harder than the others (these balls will throw higher than the other balls), and if four are not round (these balls will throw inside and outside). THIS LEAVES THE USER WITH THE IMPRESSION THAT THE HEATER SOFTBALL PITCHING MACHINE IS INACCURATE WHICH IS NOT CORRECT. IT IS THE QUALITY OF THE 12" SOFTBALLS BEING USED.





# 12" Softball Pitching Machine Instructions

## IMPORTANT

**DO NOT RETURN THIS PITCHING MACHINE TO THE RETAIL STORE WHERE PURCHASED.  
CALL TOLL FREE: (800) 492-9334.**

**WARNING:** THIS PRODUCT IS TO BE USED BY ADULTS ONLY. SERIOUS BODILY INJURY MAY OCCUR! MAKE SURE MACHINE IS TURNED OFF BEFORE ASSEMBLY! KEEP HANDS AND ALL BODY PARTS AWAY FROM BASEBALL ENTRY AND EXIT! SERIOUS HAND AND BODILY INJURY MAY OCCUR!

## SOFTBALL PITCHING MACHINE LEG ASSEMBLY

**STEP 1:** Slide Sections A, B, and C together. Lock the sections together by making sure the push pins line-up with each adjoining hole and lock into place.

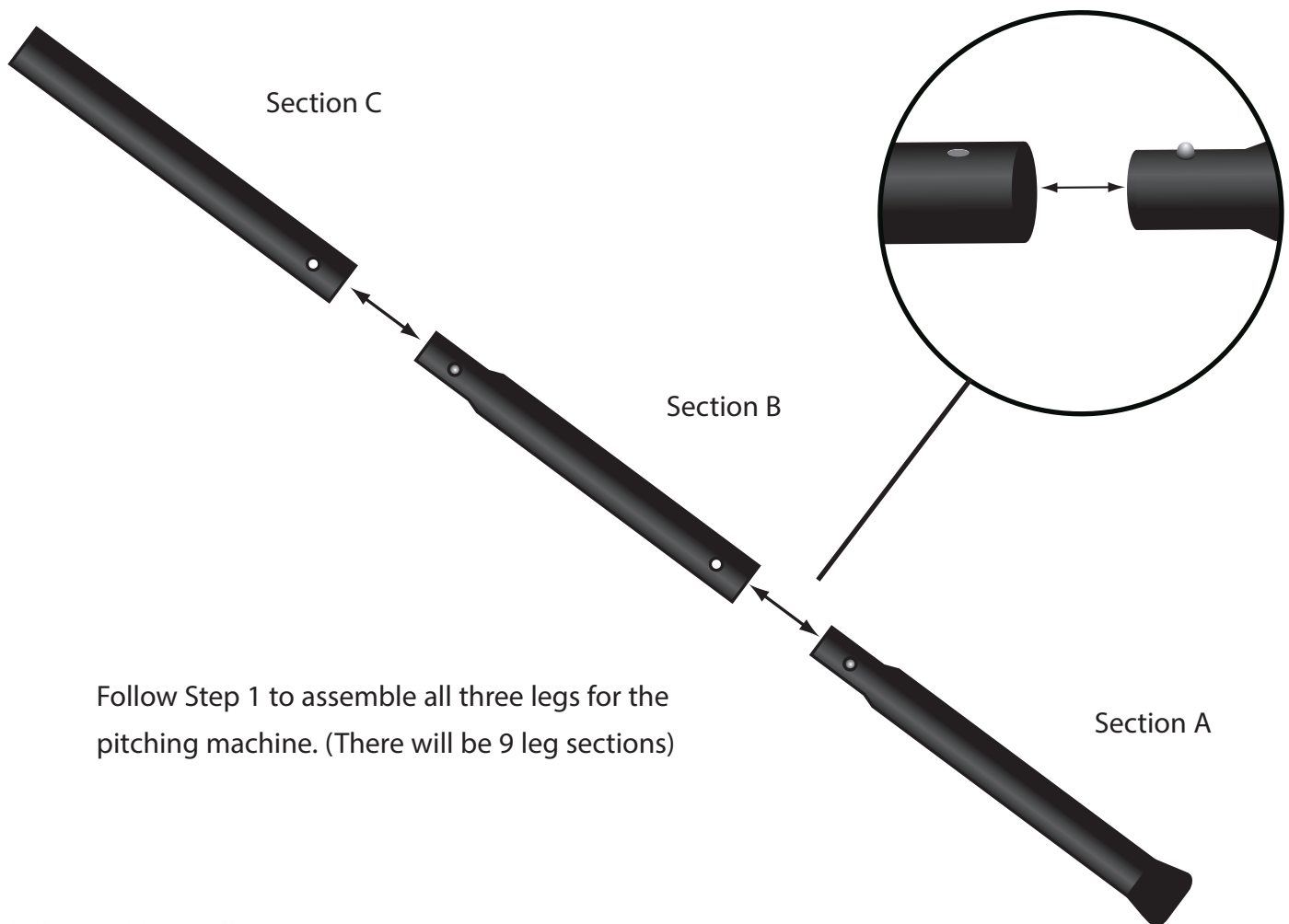

Follow Step 1 to assemble all three legs for the pitching machine. (There will be 9 leg sections)



Model# HTR6000SB/NBF

## **PITCHING MACHINE AUTO-BALL FEEDER ASSEMBLY (NOT PROVIDED WITH MODEL# HTR6000SBNBF)**

**STEP 1:** Slide Sections A - B - C Together.

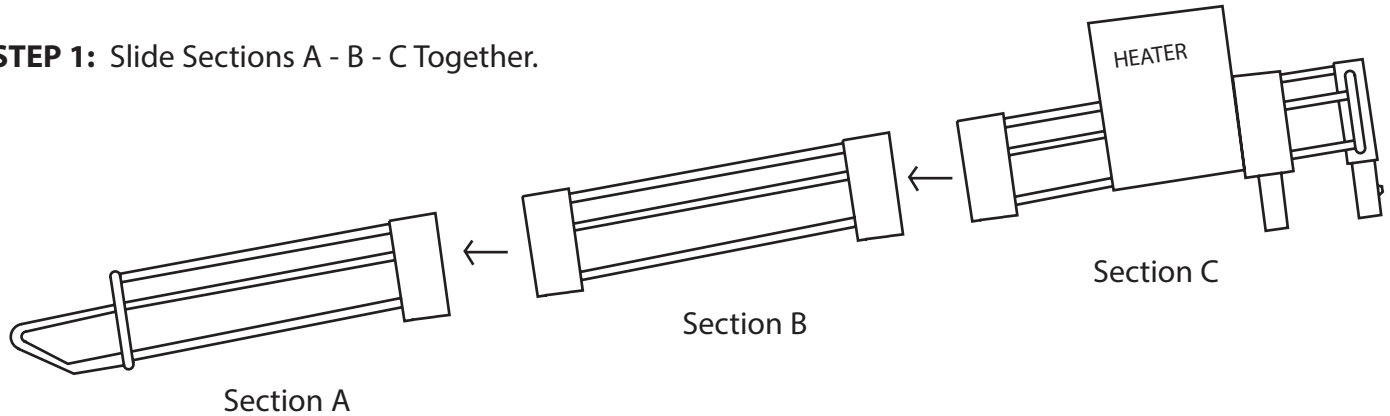

**STEP 2:** Insert 1/4" Short Bolt From Inside Of Feeder Through Hole In Feeder Bracket (4X).

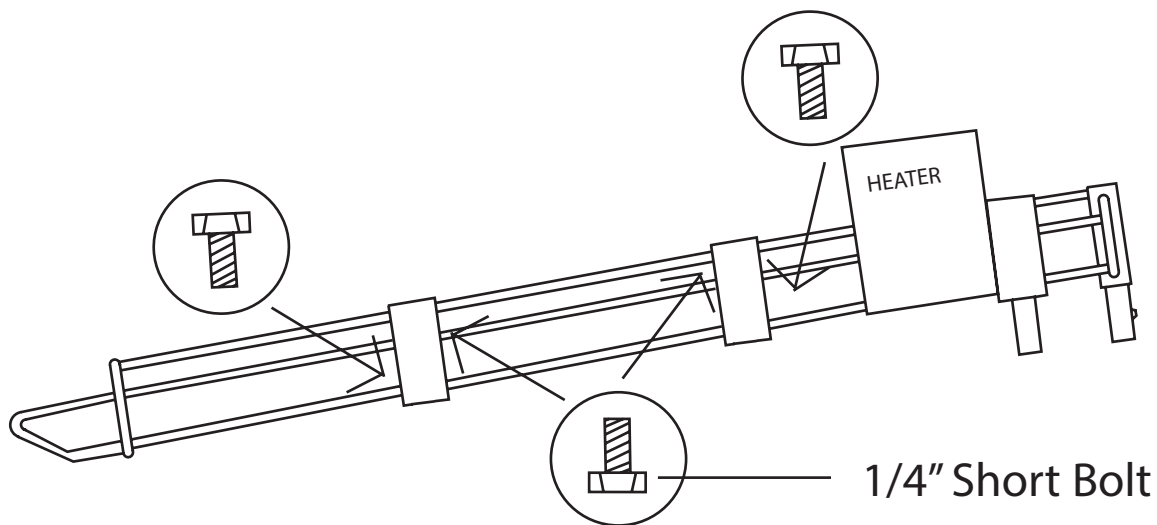

**STEP 3:** Place Washer Over Short Bolt. Screw on Nut And Tighten Nut (4X).

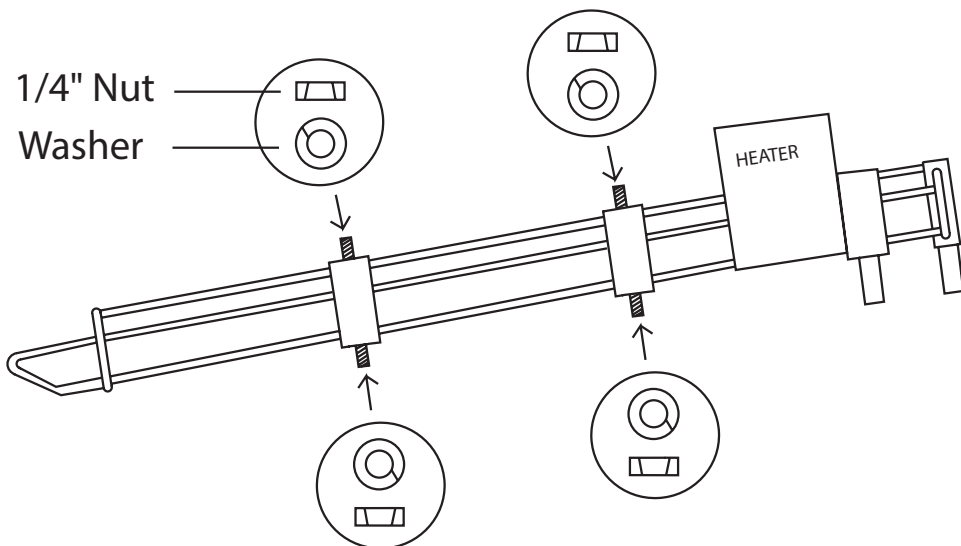

### **WARNING • WARNING**

- Turn off pitching machine and auto-ball feeder motor when loading balls.
- Make sure batter is ready before turning on auto-ball feeder and machine.
- Make sure all persons stand clear of pitching machine and ball path.
- Make sure all persons are aware pitching machine is throwing balls automatically.
- Make sure machine operator is ready to turn off auto-ball feeder power switch if necessary.



# Softball Pitching Machine Instructions

## **WARNING! WARNING! WARNING!**

**USE REAL SOFTBALLS IN THIS MACHINE AT YOUR OWN RISK!**

**IT IS RECOMMENDED THAT YOU ONLY USE DIMPLED PITCHING MACHINE SOFTBALLS TO PITCH TO BATTERS. PITCHING MACHINES THAT USE A WHEEL TO THROW SOFTBALLS WILL THROW REAL SOFTBALLS INACCURATELY BECAUSE OF THE SEAMS ON THE SOFTBALL AND MAY HIT A BATTER AND CAUSE PHYSICAL INJURY!**

**IMPORTANT: THIS PRODUCT IS TO BE USED BY ADULTS ONLY. SERIOUS BODILY DAMAGE MAY OCCUR! MAKE SURE MACHINE IS TURNED OFF BEFORE ASSEMBLY! KEEP HANDS AND ALL BODY PARTS AWAY FROM BASEBALL EXIT! SERIOUS HAND AND BODILY INJURY MAY RESULT!**

- Step 1: Slide steel legs into leg support tubes and make sure push pin locks in place.
- Step 2: Insert auto-ball feeder tubes into auto-ball feeder bracket (2X) and plug in to housing.
- Step 3: Place balls into auto-ball feeder if your model includes it (Make sure the pitching machine is not plugged in.)
- Step 4: Turn pitching machine variable speed control knob off (counter-clockwise until you hear a click).
- Step 5: Plug pitching machine into 3 prong power outlet. (Make sure pitching machine wheel is not spinning.)
- Step 6: Aim pitching machine at desired target.
- Step 7: Make sure every person and everything is clear of pitching machine ball path.
- Step 8: Turn variable speed control knob on (clockwise to approximately #4 on speed control).
- Step 9: Make sure batter is ready and turn on the auto-ball feeder.
- Step 10: Adjust softball pitch height by loosening the Pitch Height Adjustment Knob and rotating the Softball Housing to desired location. Re-tighten Pitch Height Adjustment Knob.

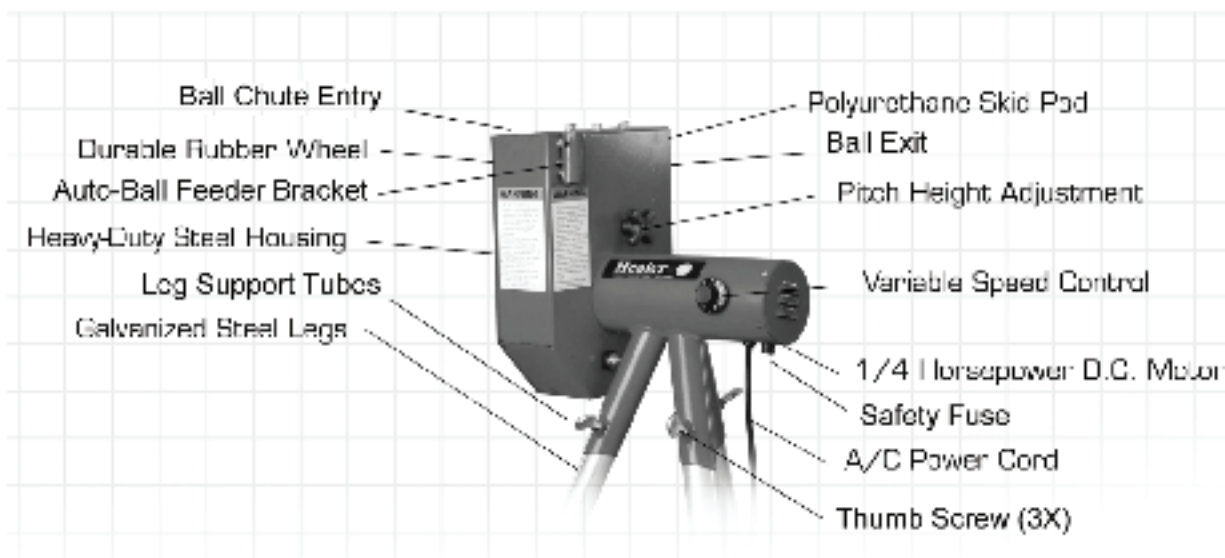

**Model# HTR6000SB/NBF**

## WARNING!

- Do not put hands or fingers in pitching machine.
- Make sure all persons are clear of the softball path and away from pitching machine before pitching any softball.
- Make sure you pitch only one softball at a time.
- Make sure all softballs are out of machine before turning the pitching machine on.
- Do not stand in front of pitching machine.
- Do not operate in moisture.
- This machine may cause serious bodily injury.
- For adult operation only.
- Batter must wear NOCSAE Approved Batting Helmet.
- Pitching Machine Operator must stand behind protective safety screen.

## WARNING!

- Only use dimpled pitching machine softballs to pitch to batters. Pitching machines that use a wheel to throw softballs will throw real softballs inaccurately because of the seams on the softball and may hit a batter and cause physical injury.
- Always have back legs staked into the ground before pitching to a batter or the Heater Pitching Machine may move and hit the batter and cause serious physical injury.
- Make sure you pitch only one softball at a time.
- Batter must wear NOCSAE Approved Batting Helmet.
- Pitching Machine Operator must stand behind protective safety screen.

### WARNING • WARNING • WARNING

- Turn off pitching machine and auto-ball feeder motor when loading balls.
- Make sure batter is ready before turning on auto-ball feeder and machine.
- Make sure all persons stand clear of pitching machine and ball path.
- Make sure all persons are aware pitching machine is throwing balls automatically.
- Make sure machine operator is ready to turn off auto-ball power switch if necessary.

### ACCESSORIES AVAILABLE

- Xtender Backyard Batting Cage.

- Use this pitching machine for both batting and fielding practice.

Thank you for purchasing the Heater Pitching Machine. If you have any questions or comments on how Heater Sports can improve the Heater Pitching Machine, please call our 24 hour customer service hotline at (800) 492-9334.



**Model# HTR6000SB/NBF**

# AIR FILLED WHEEL ADDENDUM

## Check The Air Pressure In The Heater Softball Pitching Machine Tire.

**Warning:** Make sure Heater Pitching Machine is unplugged and the tire is not spinning during these operations.

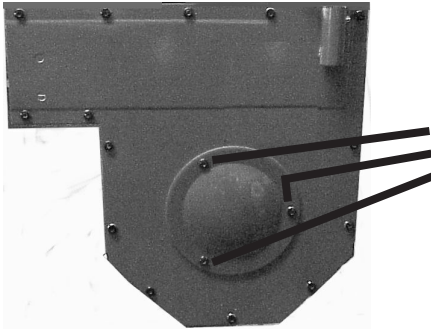

### **Pre-Operation #1**

Locate Allen Wrench (provided in package) and unscrew (3) three wheel cover screws.

### **Important:**

Make sure machine is unplugged and tire is not spinning during the following operations.

••• Periodically inspect the tire to make sure it is not worn out or punctured. Serious damage could result if operated in this condition •••

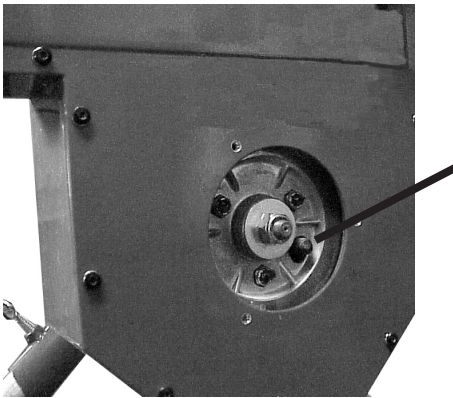

### **Pre-Operation #2**

Tire pressure should be between 30 - 32 lbs. psi. If tire pressure reads low, use an air pump to inflate the tire to 30 - 32 lbs. psi. If tire pressure reads high, decrease the air pressure by pushing down the air stem bubble located in the middle of the air stem. ••Inspect the air pressure periodically to make sure air pressure is still within the 30 - 32 lbs. psi range. ••

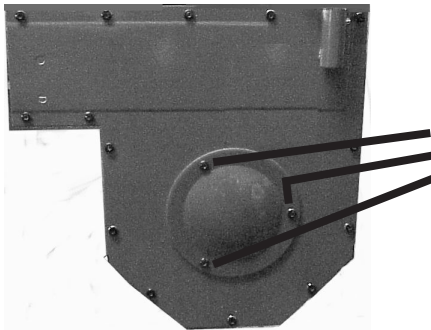

### **Pre-Operation #3**

Locate Allen Wrench (provided in package) and secure Wheel Cover back on machine by tightening (3) three Wheel Cover Screws.

**Warning - Serious Bodily Injury:** Never operate Heater Pitching Machine until Wheel Cover is secured on the Heater Pitching Machine with the (3) three Wheel Cover Screws.

## **Check Heater Fuse Reset Button**



### **Fuse Re-Set Button**

The Heater Pitching Machine has a fuse reset button which is designed to protect the electronic circuit in the Heater Pitching Machine. If the Heater will not turn on, check this button to make sure it is not popped out. If it is popped out, press it back in to reset the fuse circuit breaker. This should allow the Heater to operate safely again.