

Heater[®] Team

OWNER'S MANUAL

Blaze™ Combo Pitching Machine

www.HeaterSports.com

Model No: BPM599C

Serial No. _____

Write the serial number in the space above for reference.

ACTIVATE YOUR WARRANTY

To register your product and activate your warranty, call 1-800-492-9334

CUSTOMER CARE

For customer service inquiries, please call our toll free line at 1-800-492-9334.

⚠ CAUTION

Read all precautions and instructions in this manual before using this product. Keep this manual for future reference.

Instructions Date: 09/2023
Version: 00001



DO NOT RETURN TO STORE, CALL 1-800-492-9334

PARTS LIST

***Call Heater Sports at 1-800-492-9334 To Order Replacement Parts.**

Legs



Leg Assembly (9 Total)
 Bottom Leg (A): 3x
 Middle Leg (B): 3x
 Top Leg (C): 3x

Tripod



Tripod (D)

Hardware Pack: Tripod Assembly



Large Locknut (K)



Small Flat Washer (J)



Hex Bolt (I)



Pitch Height Knob (H)



Large Flat Washer (G)



Tripod Bracket (4x) (E)



Carriage Bolt (F)

Housing & Wheel (Pre-Assembled)

Housing (L)



Wheel Assembly (M)

*Pre-Installed Flat Washer (N)



*Pre-Installed Locknut (O)



Hardware Pack: Pinch Pad Knob



Pinch Pad Knob (P)

Pinch Pad



Ball Type/
Pinch Pad (Q)

Ball Chutes



9" Baseball Chute (R)



11" & 12" Softball Chute (S)

Hardware Pack: Ball Chute Knob



Ball Chute Knob (T)

EXPLODED VIEW ASSEMBLY

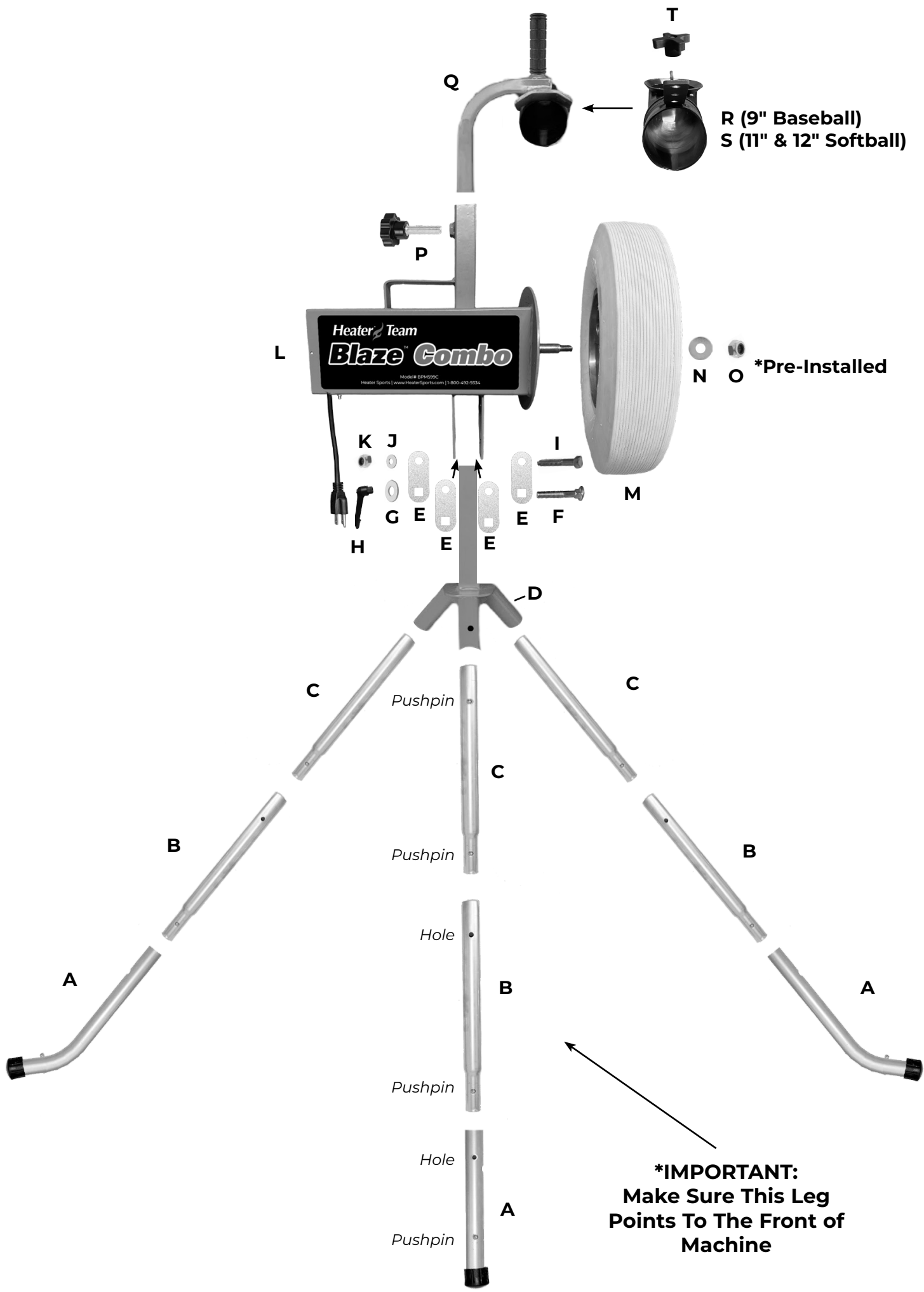

TRIPOD TO HOUSING ASSEMBLY

Step 1:

Insert Tripod (D) into bracket of Housing (L) and line up holes. Make sure single leg of Tripod lines up with flat side of housing bracket.

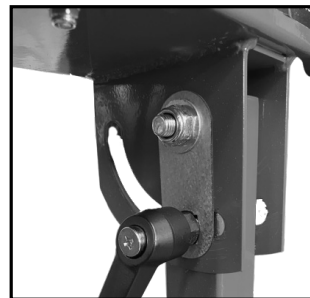
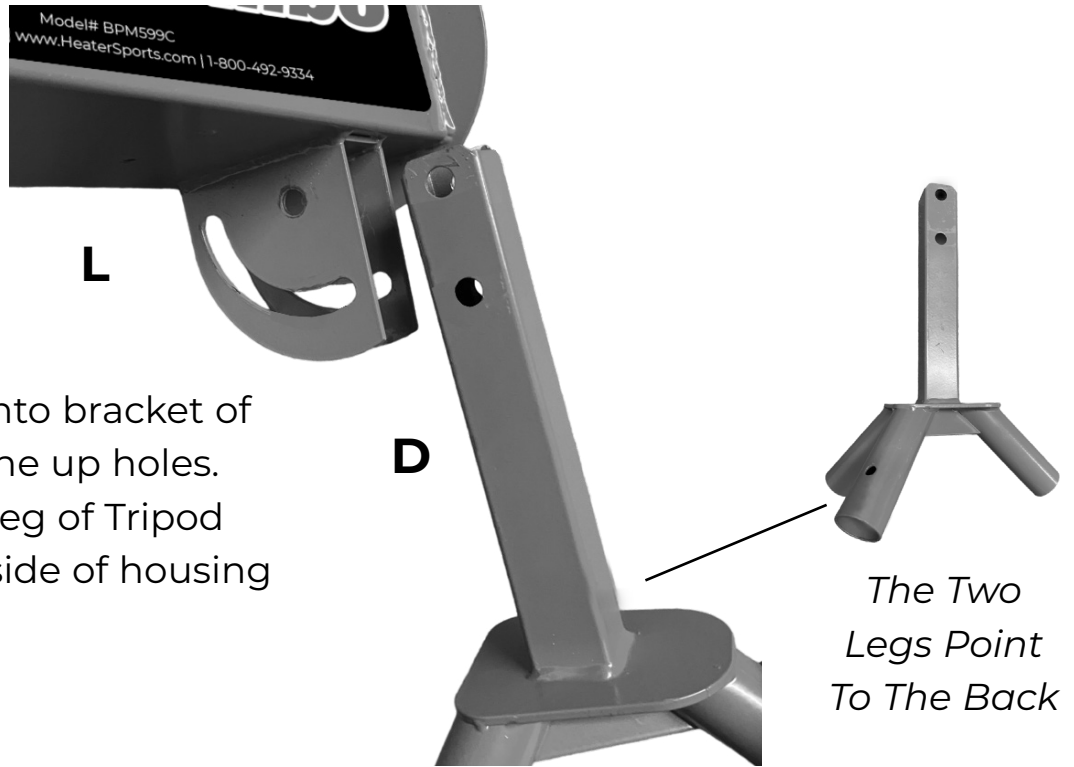

Outside Left

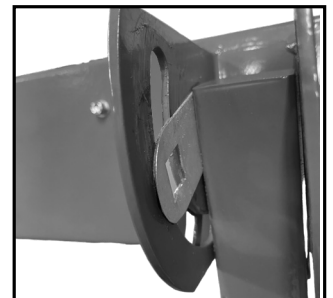

Inside Left

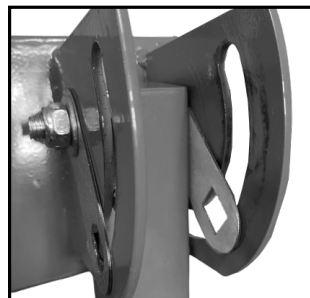

Inside Right



Outside Right

*Assembled 4 Brackets
(Front View)*

Step 2: Install Tripod Hardware as shown above. Ensure all 4 brackets (F) are installed and Top Bolt Hardware (E, G, H) is tightly secured.

LEG TO TRIPOD ASSEMBLY

Step 3: Insert & Lock Pushpins of Legs A, B, and C (3 times) together.

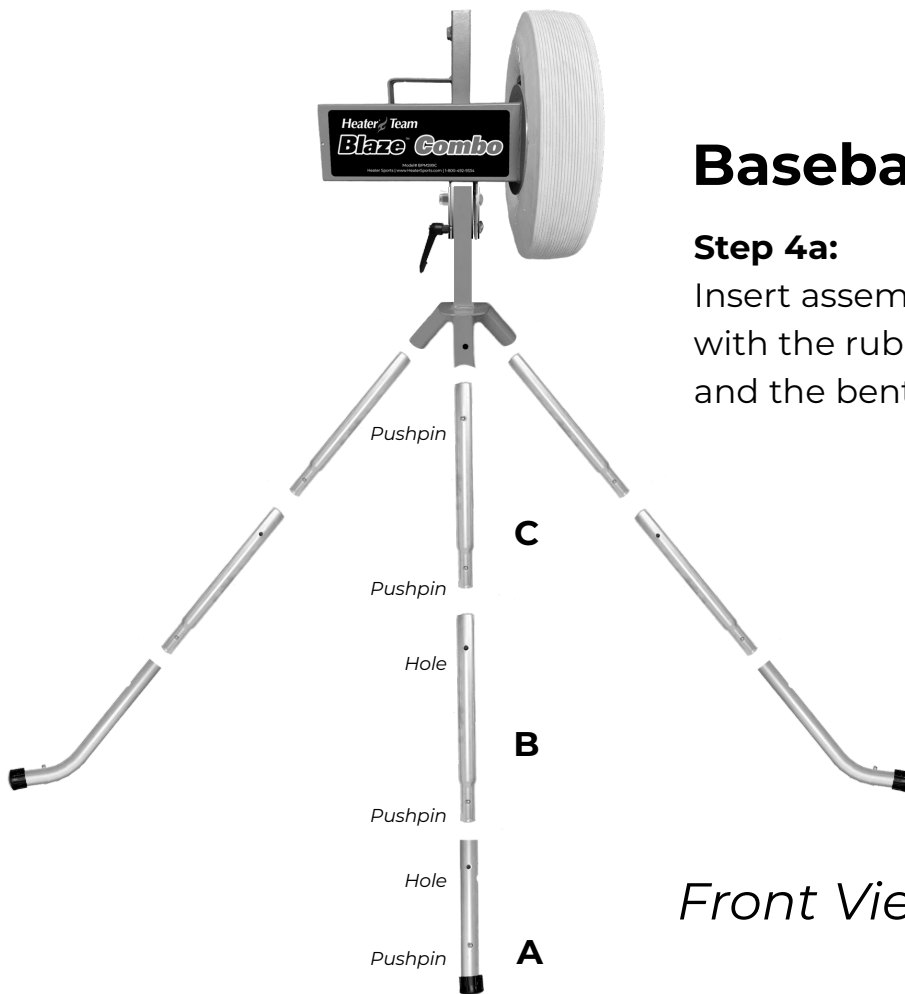

Baseball Setup

Step 4a:

Insert assembled leg sections into Tripod with the rubber tip installed on the bent leg and the bent leg touching the ground.

Front View

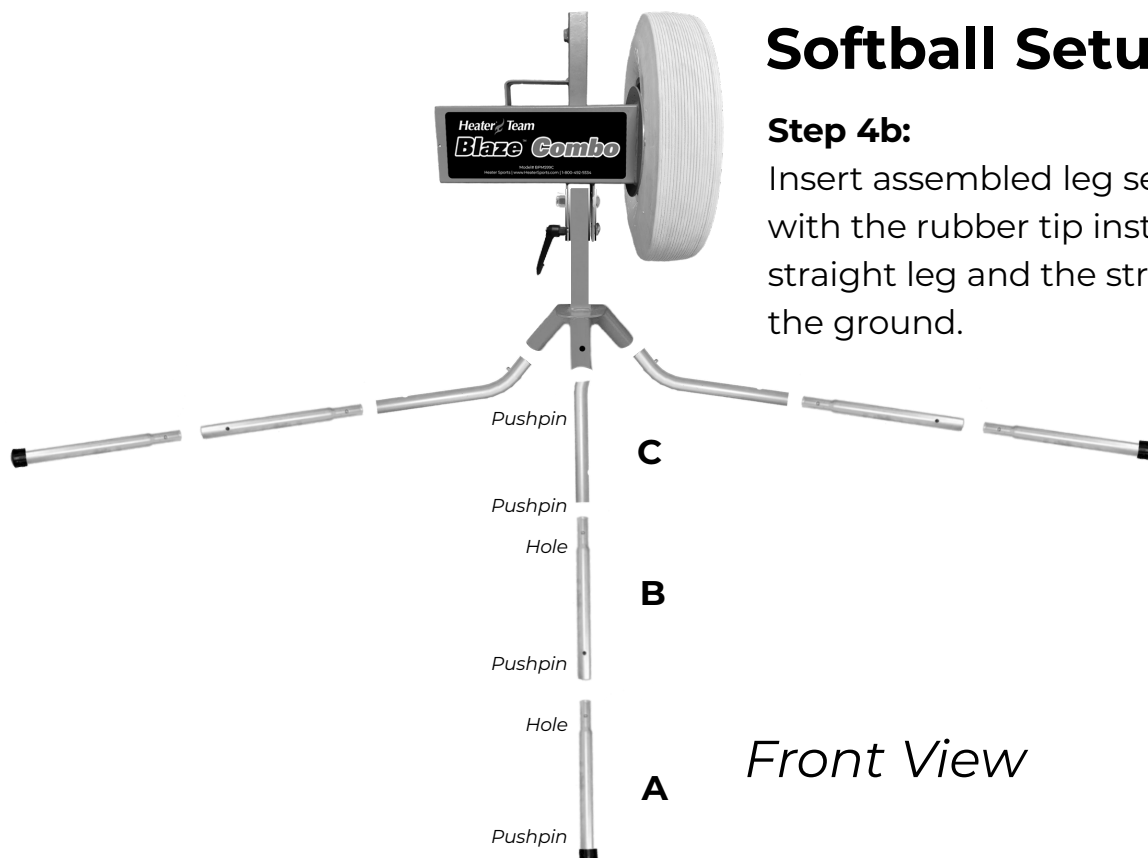

Softball Setup

Step 4b:

Insert assembled leg sections into Tripod with the rubber tip installed on the straight leg and the straight leg touching the ground.

Front View

PINCH PAD & CHUTE ASSEMBLY

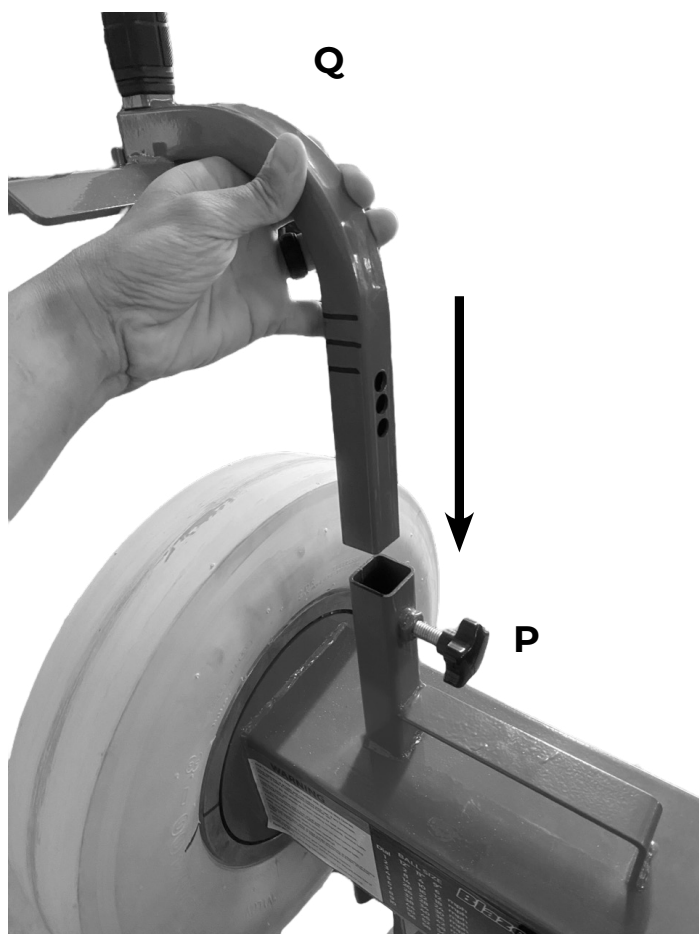

Step 7:

Insert Pinch Pad (Q) into housing and tighten Knob (P) into pre-determined 9", 11", or 12" ball type hole.

*Make sure Knob is screwed down tight and fully inserted into hole.

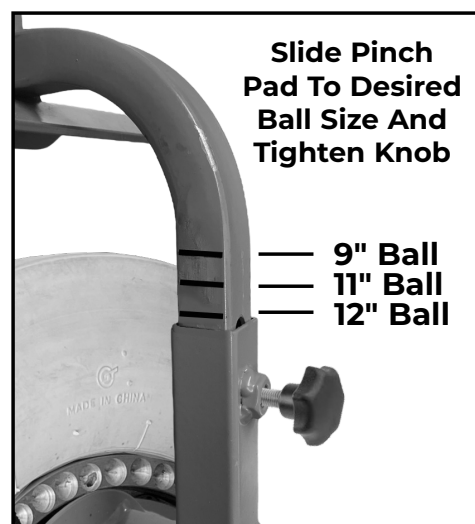

R or S Ball Chute

Step 8:

Attach either the 9" Baseball Chute (R), or 11" & 12" Softball Chute (S) to the Pinch Pad using the Chute Knob (T).

Use only the correct Ball Chute for the correct ball feeding into machine.

Be sure the Pinch Pad Hole Corresponds to the ball size you are pitching.

ASSEMBLED VIEW

Baseball Setup



Part# R (9" Baseball Chute)

Ball Exit

Handle Must Be Installed On This Side Of Tripod.

***IMPORTANT:**
Single Leg Goes To Front Of Machine

Softball Setup

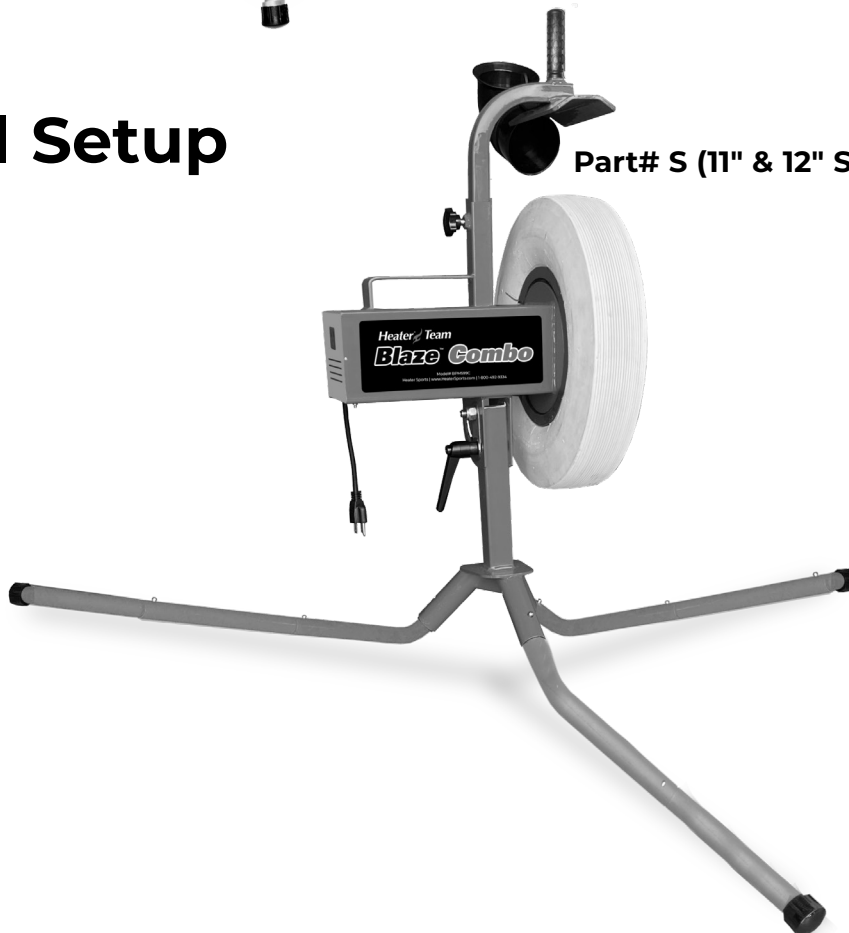

Part# S (11" & 12" Softball Chute)

WARNING

THE BLAZE COMBO PITCHING MACHINE SHOULD BE OPERATED BY ADULTS ONLY

THIS MANUAL MUST BE KEPT WITH THE MACHINE AT ALL TIMES. EACH OPERATOR MUST READ AND UNDERSTAND THE INSTRUCTIONS BEFORE USING THE MACHINE.

NEVER USE OR LEAVE THE MACHINE IN RAIN/MOISTURE. DOING SO CAN RUIN THE MACHINE & VOID ITS WARRANTY.

HEATER SPORTS RECOMMENDS USING HEATER PITCHING MACHINE BALLS IN THIS MACHINE. THESE BALLS HAVE BEEN PRECISELY CRAFTED TO PROVIDE YOU WITH HOURS OF ACCURATE, TROUBLE FREE BATTING AND FIELDING PRACTICE. OTHER BRAND OF BALLS HAVE NOT BEEN TESTED IN THIS MACHINE AND CANNOT BE VALIDATED AS SUFFICIENT AND SAFE.

Heater Dimpled Pitching Machine Balls are recommended for use with this machine. These balls are incredibly accurate, long lasting, and produce the fastest ball speed.

This machine works well with real leather balls; however, accuracy will vary more than with pitching machine balls because the seams on leather balls cause the machine to pinch the ball differently on each pitch. Be sure and use real leather balls, not simulated leather balls. and should be low-profiled red seams. Batters should be aware at all times.

KNOWN PROBLEMS WITH SIMULATED (SYNTHETIC) LEATHER COVERED BALLS . . .

Simulated (synthetic) leather balls:

Simulated leather balls are inexpensive seamed balls that don't work well in this machine. During operation, portions of the simulated leather cover comes off the ball and attaches to the wheel. Also, during operation, consumers have reported seeing small puffs of smoke coming out of the machine. These puffs are not smoke, but actual pieces of the simulated leather ball being turned into small dust particles as they pitch.

IF BALLS GET WET, THEY WILL NOT PITCH PROPERLY UNTIL THEY DRY.

KNOWN FACTS ABOUT DIFFERENT BALLS:

The speed and accuracy of each pitch is dependent on the hardness, roundness, and type of each ball used.

For example: If you have 12 balls and 4 are softer than the others (these balls will throw lower than the other balls), if four are harder than the others (these balls will throw higher than the other balls), and if four are not round (these balls will throw inside and outside). **THIS COULD LEAVE THE USER WITH THE IMPRESSION THAT THE PITCHING MACHINE IS INACCURATE WHICH IS NOT CORRECT.**

PRE-OPERATION

WARNING: The Blaze Combo pitching machine is intended for use by operators who are at least 18 years of age and who have been educated about the safety precautions and operations of the machine.

WARNING: Do not attempt to operate this machine until you have read thoroughly and understand completely all instructions, safety rules, machine labels, etc. contained in this manual. Failure to comply can result in accidents involving electric shock or serious personal injury. Save this Owners Manual and review frequently for continuing safe operation, and for instructing others who may use this machine.

WARNING: Do not connect your pitching machine to a power source until you have assembled and adjusted the machine as described in this manual and have read and understood all precautions and operating instructions in the manual and printed on the machine.

READ THIS MANUAL:

- > Know Your Pitching Machine. Read the Owner's Manual carefully. Learn the machine's capabilities, features and limitations as well as the specific potential hazards related to this machine.
- > Guard against electrical shock by preventing body contact with grounded surfaces. For example: radiators, pipes, fences, or other enclosures.
- > Keep the operator's area free of clutter. Pick up all loose balls around the machine and keep ball supply in a pail, bucket or other suitable container. Cluttered operating areas invite accidents.
- > Do not allow children to operate the pitching machine. You must be at least 18 years of age or older and instructed in the proper operation, maintenance, care, and storage of this machine before operating it. Close supervision is necessary when this machine is used near children.
- > Inspect extension cords periodically and replace if damaged.
- > Use the proper extension cord. Make sure your extension cord is in good condition. When using an extension cord, be sure to use one heavy enough to carry the current your machine will draw. An undersized cord will cause a drop in line voltage resulting in loss of power and overheating. A wire gauge size (A.W.G.) of at least 16 is recommended for an extension cord 25 feet or less in length. If in doubt, use the next heavier gauge. The smaller the gauge number, the heavier the cord.
- > Do not abuse the cord. Never yank cord to disconnect it from receptacle. Keep cord away from heat, oil, and sharp edges. Stay constantly aware of cord location and keep it well away from the rotating tire.
- > Dress properly. Do not wear loose clothing, gloves, neckties, rings, bracelets, or other jewelry. They can get caught and draw you into the moving parts. Long hair should be tied up and tucked under hats and helmets. Severe physical harm may result if loose clothing, jewelry or hair is caught in rotating tires.
- > Always wear safety glasses and batting helmets while the wheels are rotating. Debris on the tires can fly off and cause physical harm. Everyday eyeglasses have only impact-resistant lenses; they are NOT safety glasses.
- > **Never touch rotating tire.** Do not put hands or fingers into ball feed chute. Hands and fingers should only go to the edge of the chute (or the edge of the sleeve in the case of fly ball or pop-up practice).

- > Inspect machine before every use. If damaged, call Heater Sports for technical support.
- > Inspect tire & pinch pad before every use. Be sure both are free of grit and debris before turning on machine.
- > Do not use machine if 0-10 Knob does not work properly. In the unlikely event that the switch becomes defective, call Heater Sports.
- > Keep machine clean, and free of grit and dirt. With the machine unplugged, use only a clean damp cloth for cleaning. Never use brake fluids, gasoline, petroleum-based products, or any solvents to clean machine.
- > Tighten Knobs and Handles securely after adjusting trajectory.
- > To protect the operator, a pitcher's screen must be placed in front of the pitching machine.
- > Only operate and store this pitching machine in a clean, dry location. Do not use outdoors if it is raining. If machine becomes wet, do not use. A potential shock hazard exists if this machine is used while or after it has been exposed to water. Hand dry surface water from machine with a clean cloth and allow the machine to completely air dry before its next use.
- > Avoid awkward operations and hand positions where a sudden slip could cause your hand to move into the rotating tire. ALWAYS make sure you have good footing and balance.
- > All repairs, whether electrical or mechanical, should be made by a qualified Heater Sports service technician. When servicing, use only Heater replacement parts.
- > Do not operate this machine under the influence of drugs, alcohol, or any medication.
- > Stay alert and exercise control. Watch what you are doing and use common sense. Do not operate this machine tired. Do not rush.
- > Avoid accidental starting when reconnecting to a power supply. Always turn off machine before disconnecting it from power source. Never leave machine running unattended. Turn the power off. Do not leave machine until tires come to a complete stop.
- > Do not allow your familiarity with the machine to cause you to be careless. Remember that a careless fraction of a second is enough time to inflict severe injury to yourself or others.

Grounding Instructions

This product must be grounded. If it should malfunction or break down, grounding provides a path of least resistance for electric current to reduce the risk of electric shock.

Do not modify the plug provided. Improper connection of the equipment-grounding conductor can result in a risk of electric shock.

If repair or replacement of the electric cord or plug is necessary, contact Heater Sports for proper power cord replacement and instructions.

Extension Cords

Use only 3-wire 16 AWG or larger grounding type extension cords that have 3-prong grounding plugs and 3-pole receptacles that accept the machine's plug. When using the machine at a considerable distance from a power source, use an extension cord heavy enough to carry the current that the machine will draw. An undersized extension cord will cause a drop in line voltage, resulting in a loss of power and causing the motor to overheat.

Electrical Connection

Your Blaze pitching machine is powered by a 90 volt motor. Do not operate this machine on direct current (DC). A substantial voltage drop will cause a loss of power and the motor will overheat. If the machine does not operate when plugged into an outlet, double check the power supply. Your pitching machine will operate under a standard 110 voltage AC outlet. Do not use an adapter with this product.

OPERATION

IMPORTANT: Always position the pitching machine so that one leg is facing the pitching screen and batter, and two legs are facing back, towards the operator.

- Step 1:** Ensure the tall legs are assembled for baseball and the short legs are assembled for softball.
- Step 2:** Ensure the smaller baseball chute is installed for baseball and the larger soft ball chute is installed for softball.
- Step 3:** Ensure the pinch pad is set and knob is tightened to the correct hole for 9" ball, 11" ball, or 12" ball.
- Step 4:** Ensure tire PSI is set between 13-17 at all times. Check prior to each use.
- Step 5:** Connect a 3 prong extension cord into a grounded 110V AC outlet.
- Step 6:** Ensure ball path in front of machine is clear of people and object.
- Step 7:** Turn machine setting to speed 3 and pitch a ball to test aim and velocity.
- Step 8:** Adjust speed and height to target into desired area.

Pitching to Batters

Follow all safety performance instructions in this manual. The following feeding instructions should be used to ensure accurate and efficient operation of the Blaze Pitching Machine.

IMPORTANT PITCHING MACHINE FEEDING INSTRUCTIONS:

- > When feeding the machine with leather balls, hold the ball the same way every time. Across the seams is best.
- > Have all batters and observers stand well clear of the target as you throw test balls to adjust trajectory and aiming point.
- > **VERY IMPORTANT:** Before you place the ball in the feeding chute, you should look up at the batter and make absolutely sure the batter is watching you and is ready to receive the pitch. It is extremely important that you make sure that the immediate area in front of the pitching machine and the flight path of the ball is clear before you feed the balls into the pitching machine.

- > Out-of-round, soft, mushy, or wet balls will affect accuracy of pitches and must not be used. Mixing different types of balls (leather, rubber, etc.) will affect consistency of pitches. For best accuracy, throw only one type of ball at a time.
- > Do not permit more than one or two persons around the pitching machine during its operation.
- > When the batter has taken his/her stance and indicates he or she is ready to hit, hold the ball high in the air where the batter can see the ball. Then bring the ball down to the chute simulating live action so that the batter can time the ball correctly. Set the ball in the feed chute and release. Do not drop the ball into the chute. Watch the ball into the wheel, then look up at the batter. The whole feeding operation should be smooth and without interruption.
- > To adjust the height of the pitch or trajectory for fly balls, loosen the Height Adjustment Knob (located underneath the motor) a half turn. Grab the rubber grip on top of the Pinch Pad and pull back toward you (the operator) to raise the height. Push forward away from you (the operator) to lower the height and tighten the Knob securely. (You will have to practice this targeting so you will know how to set the machine for each pitch.)
- > Batters MUST WEAR NOCSAE APPROVED BATTING HELMETS AT ALL TIMES.
- > Operators of Blaze Pitching Machine must wear safety glasses and batting helmets at all times
- > NOTE: We suggest that each operator spend a couple of hours experimenting with the Blaze Pitching Machine. Try many different speed settings. You should use a wide & tall backstop when experimenting with faster speeds.
- > At the beginning of practice, or after any change in speed, or trajectory, have the batter stand well clear while at least two test balls are thrown to make sure the ball is thrown at the desired target. If you move the machine for any reason, repeat this process.
- > Check tightness of all bolts and nuts at regular intervals. If any looseness, vibration, or rattle is noticed, correct immediately before further use.

ESTIMATED SPEED

BALL SIZE					
Dial	12"	11"	9"	9" Lite	
1	2	4	6	7	mph
2	8	10	12	14	mph
3	14	16	18	21	mph
4	20	22	24	28	mph
5	26	28	30	35	mph
6	32	34	36	42	mph
7	38	40	42	49	mph
8	44	46	48	56	mph
9	50	52	54	63	mph
10	56	58	60	70	mph

MAINTENANCE

Review the following instructions carefully to maintain maximum accuracy with your Blaze Pitching Machine.

- > Maintain tire pressure at 13 to 17 psi.
- > Keep machine clean, and free of grit and dirt. Always use a clean damp cloth when cleaning. Never use brake fluids, gasoline, petroleum-based products, or any solvents to clean machine.
- > Periodically, you must clean the tires to help maintain their maximum performance. A dirty tire can easily be distinguished by either a dark ring around the tire surface or when the surface itself has turned yellow and has a very glossy or shiny finish.
- > Take medium grade sandpaper (sometimes an even coarser grade is necessary depending on the amount of soil buildup) and begin to scrub the tire surface as you would a very dirty frying pan. This process can be very tedious and could take up to 10 minutes. However, it is necessary in order to completely clean the rubber of all foreign substances, as well as prepare it for better machine performance. You should sand the tires whenever you notice the soil build-up forming. Always sand tires with the power switch OFF and the machine unplugged.
- > Once you complete this operation the tire surface will, in most cases, take on the white color it was originally. Maintaining the tire in this fashion will not only maximize the performance and accuracy of your machine, but it will extend the life of the tire.

Storage

- > Always store machine and extension cord in separate, clean, dry secured areas. Cover the machine with a suitable dust cover that does not retain moisture. Do not use plastic.

WARRANTY

Warranty

- > Your Blaze Combo includes a 30 Day Money-Back Guarantee (Customer Pays Return Shipping) and 1 Year Parts & Labor Warranty (Customer Pays Shipping). For any warranty issues or replacement part needs please contact Heater Sports.

Thank you for purchasing your Blaze Combo Pitching Machine. For any questions, comments, or needs please contact Heater Sports any of the following ways:

**Heater Sports
95 West 650 South
St. George, UT 84770**

**Online: www.HeaterSports.com
Email: MoreInfo@HeaterSports.com
Phone: 1-800-492-9334**