



-- BBFP-40 --

-- SBFP-40 --

(40' PROFESSIONAL / SOFTBALL FOUL POLE)

Installation Instructions



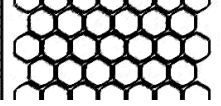
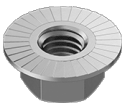






Call Jaypro Sports Equipment at 1-800-243-0533  
during regular business hours for technical support.

[www.jaypro.com](http://www.jaypro.com)

## 40' Professional / Softball Foul Pole, BBFP-40 / SBFP-40

*QUANTITY IS FOR ONE COMPLETE FOUL POLE*

ITEM	QTY	IMAGE	DESCRIPTION
1	1		TOP UPRIGHT POLE <i>P/N: BBFP-40TU</i>
2	1		BOTTOM UPRIGHT POLE <i>P/N: BBFP-40BU</i>
3	6		PANEL <i>P/N: BBPS-B</i>
4	2		1/2"-13 FLANGE NUT <i>P/N: HN5038</i>
5	4		1/2" FLAT WASHER <i>P/N: HW2044</i>
6	1		1/2"-13 x 9" LONG THREAD ROD <i>P/N: SR167</i>
7	2		1/2-13 NYLON LOCK NUT <i>P/N: HN2951</i>
8	2		1/2"-13 x 8" LONG HEX HEAD <i>P/N: HS5066</i>
ITEM	QTY	IMAGE	DESCRIPTION

- Unpack all parts and check against parts list to ensure that all have been included.
- Inspect all parts for damage. Report any damages to the trucking company.

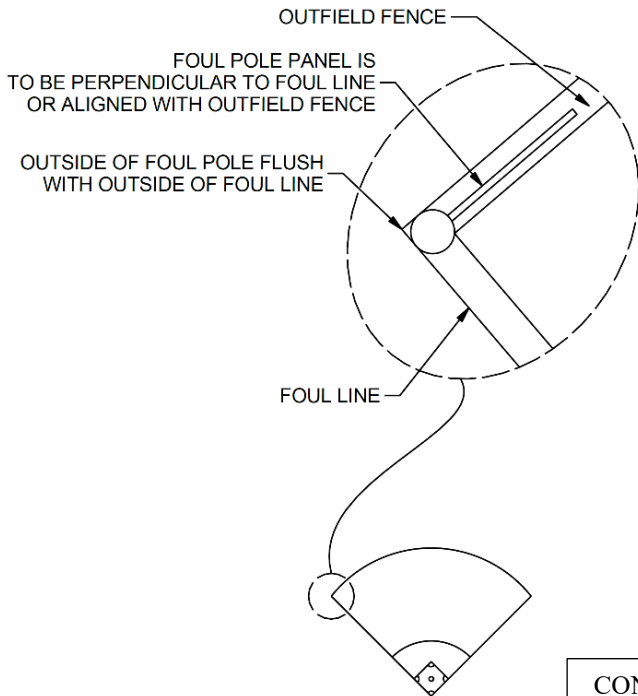
ITEM	QTY	IMAGE	DESCRIPTION
9	20		3/8" FLAT WASHER P/N: HW2047
10	10		3/8"-16 NYLON LOCK NUT P/N: HN265
11	10		3/8"-16 x 1" LONG HEX HEAD P/N: HS286
12	54		7/16" FLAT WASHER P/N: HW5042
13	18		7/16"-14 NYLON LOCK NUT P/N: HN5070
14	18		7/16"-14 x 8" LONG HEX HEAD P/N: HS5386
15	1		TOP CAP FOR 6-5/8" OD P/N: EC0070
16	N/A		OPTIONAL GROUND SLEEVE P/N: FPS-40P
18	1	 AVAILABLE IN:  YELLOW  WHITE  ORANGE	AEROSOL YELLOW RAL 1018 SINGLE CAN P/N: PT0062SC  AEROSOL ORANGE RAL 2004 SINGLE CAN P/N: PT0101SC  AEROSOL WHITE RAL 9003 SINGLE CAN P/N: PT0102SC
ITEM	QTY	IMAGE	DESCRIPTION

- Unpack all parts and check against parts list to ensure that all have been included.
- Inspect all parts for damage. Report any damages to the trucking company.

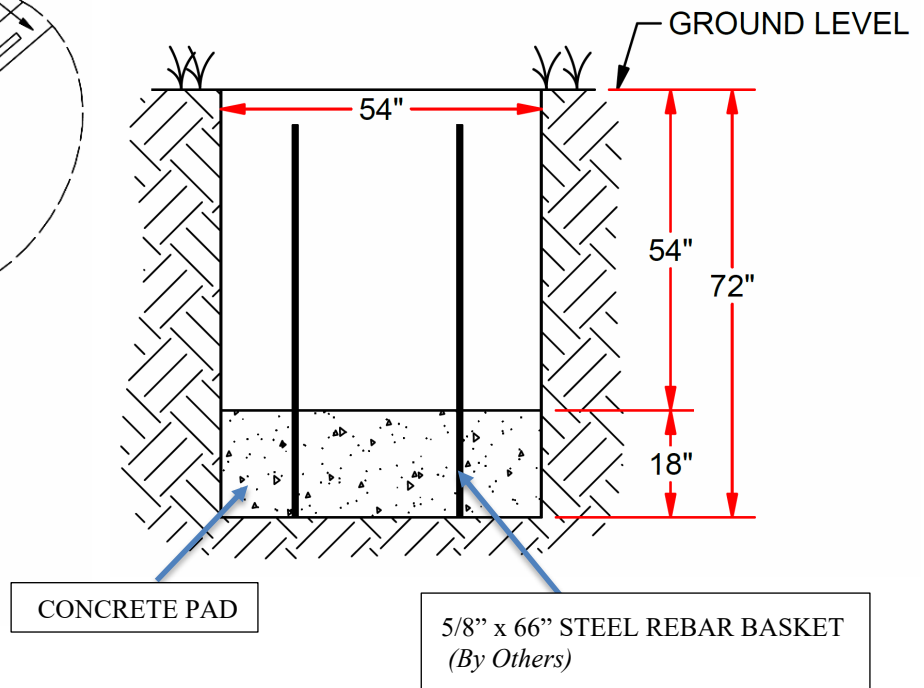
## ASSEMBLY INSTRUCTIONS

### Site Prep

1. Determine the proper location for the foul poles on the playing field, see figure 1.
2. Excavate the footing holes to the dimensions shown in figure 2. **These are suggested dimensions for average soil conditions, consult local building codes. Dimensions may need to be adjusted in areas subject to high wind loads.**
3. Pour a concrete pad at a height so the foul pole or sleeve is imbedded 54" deep. A six-piece rebar basket is recommended, allow to cure for 24 hours (see figure 2).



**FIGURE: 1**



**FIGURE: 2**

Note: These are suggested dimensions for average soil conditions, consult local building codes.

\*For Areas Subject To Higher Wind Loads  
Dimensions Will Need To Be Adjusted.  
*See wind loading spec sheet.*

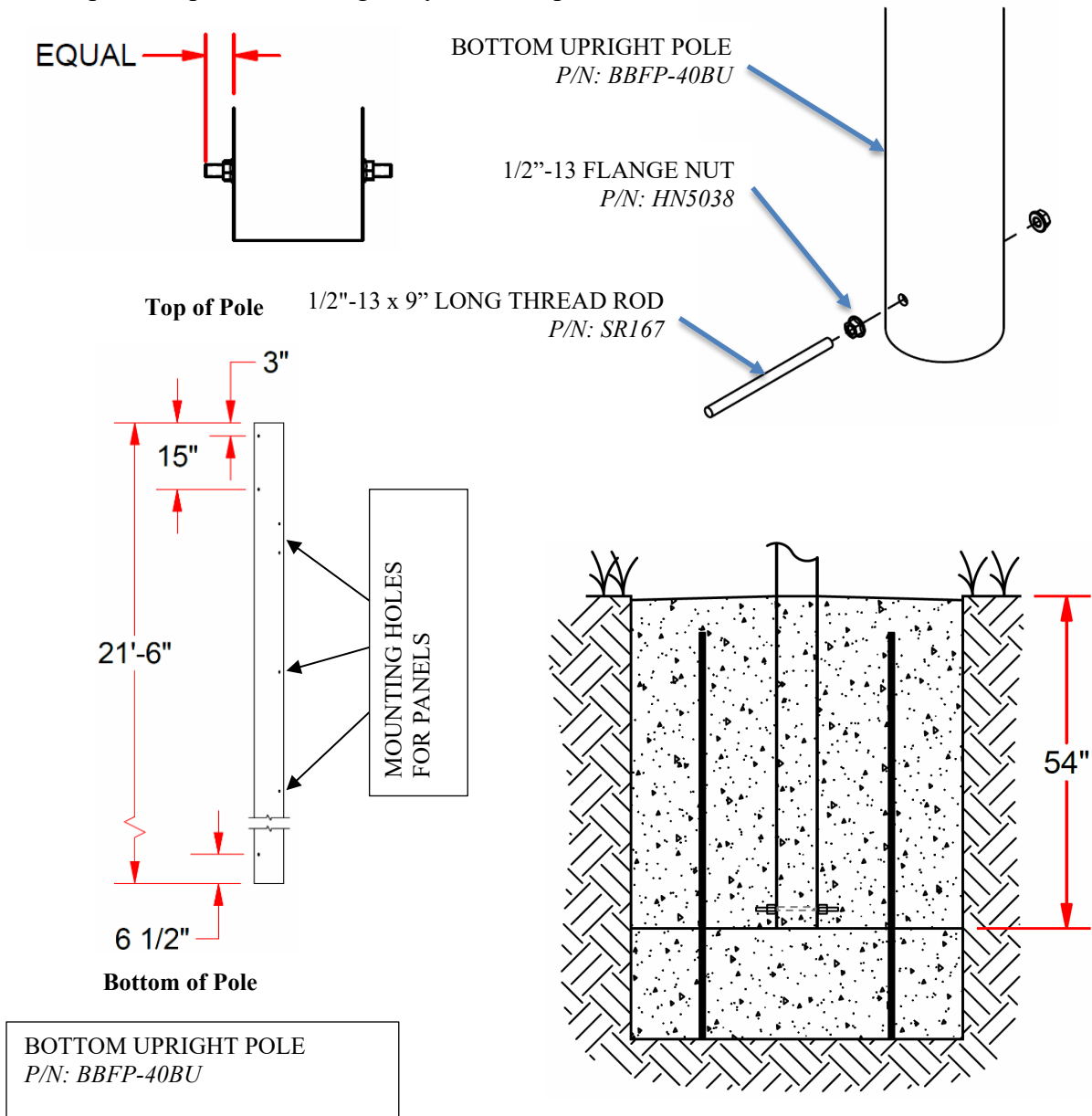
# Permanent Installation:

## Inground: No Sleeve

1. Identify the bottom pole section (see figure 3).
2. Install the anti-rotation rod into the bottom hole of the foul pole. Center the rod within the pole and install 1/2" flange nut on both ends.
3. Position and plumb the pole in the footing.

**Important: Carefully align the wing panel mounting holes in accordance with Figure 1.**

4. Support the pole to prevent it from shifting during the pour. Pour the remainder of the footing and let cure for a minimum of 96 hours before installing the top pole and panels.
5. Slope the top of the footing away from the pole for drainage.



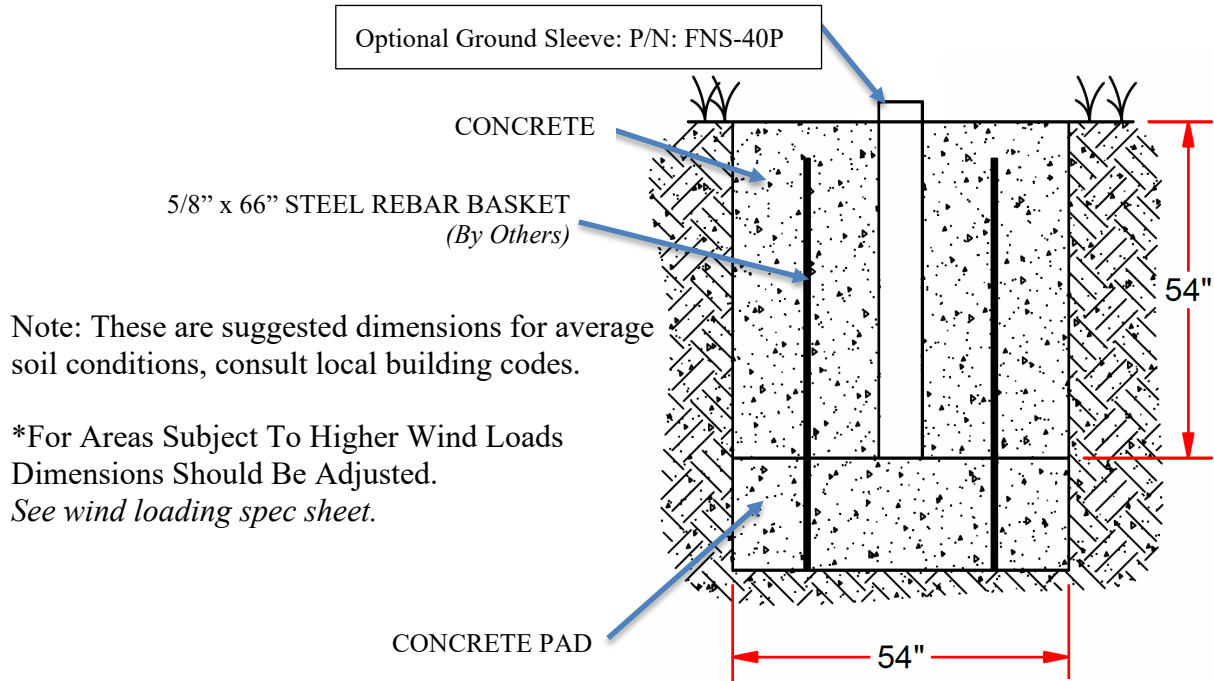
**FIGURE: 3**

**FIGURE: 4**

# Semi-Permanent Installation

## Ground Sleeve:

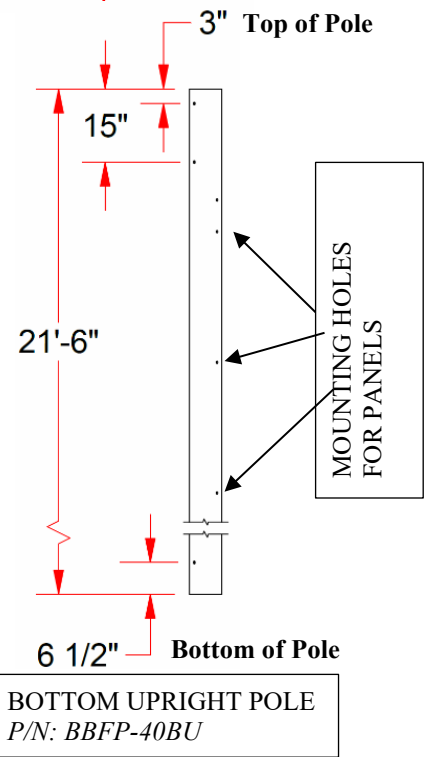
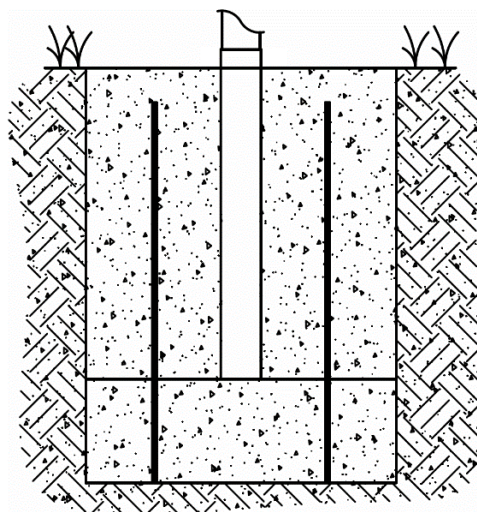
1. Place the ground sleeve into the footing and fully support it in a plumb position (figure 5).
2. Pour the remainder of the footing. Slope the top of the footing away from the sleeve for drainage. Wait for concrete to fully cure (at least 96 hours) before installing the foul pole.



**FIGURE: 5**

## Bottom Pole Section:

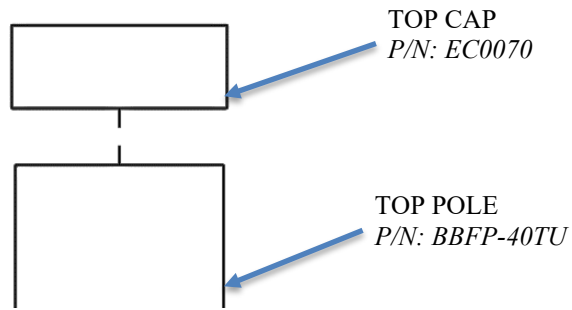
1. Identify the bottom end of the bottom pole section and insert into the sleeve (see figure 3).



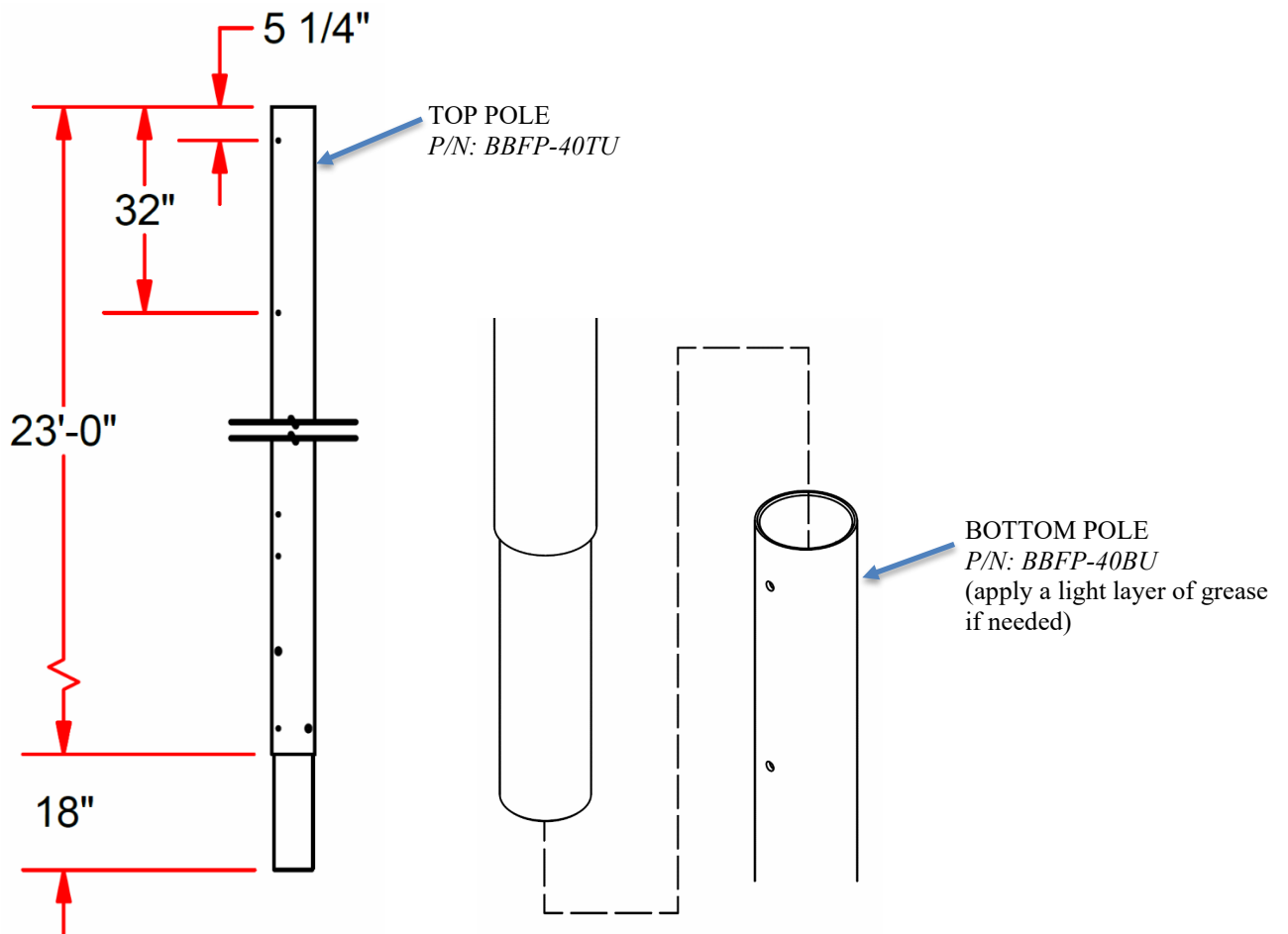
**FIGURE: 3**

**Top Pole Section:**

1. Install the top cap by tapping it on with a rubber mallet.
2. Insert the top pole into the bottom pole.
3. Line up the holes for the wing panels in both the top and bottom poles.

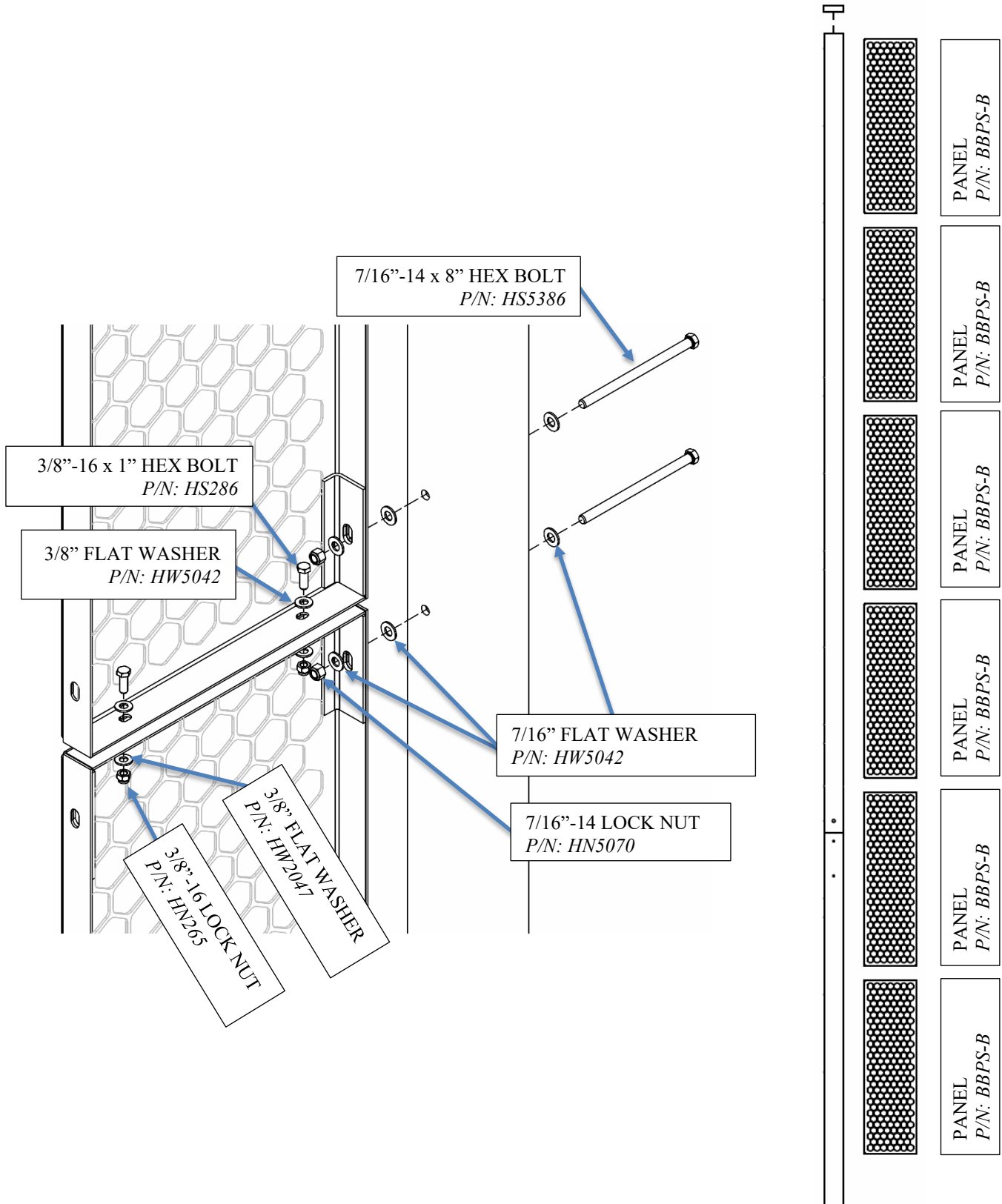


**FIGURE: 6**



**Wing Panels:**

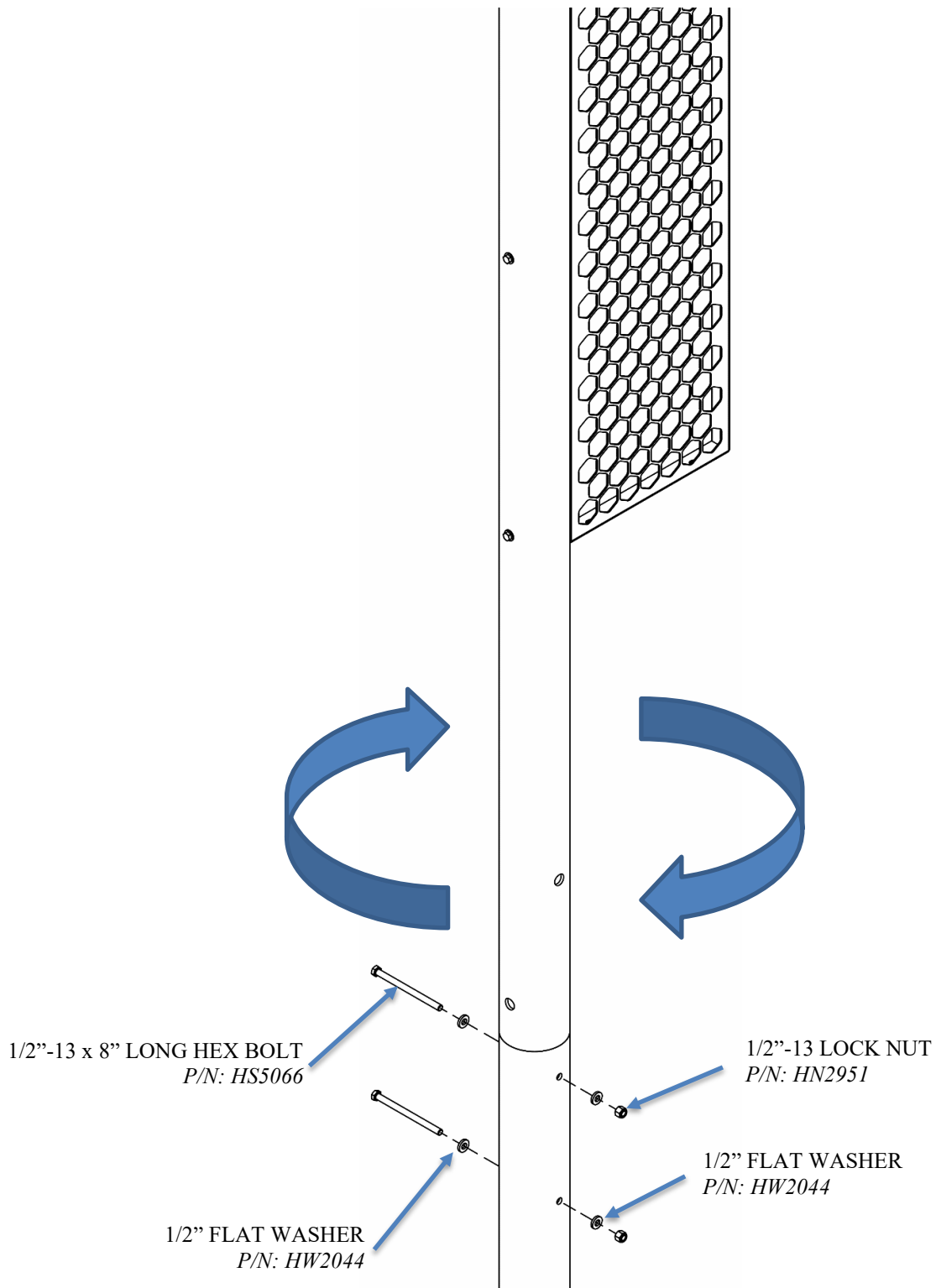
1. Attach all the wing panels per figure 7. Orient the panels so the front side is facing the field. (back side of panels shown)



**FIGURE: 7**  
(Backside of Panels Shown)



2. If needed, rotate the top pole so the wing panels attaching to the bottom pole are in line with the top.
3. Install the bottom two panels.
4. Drill the two holes in the top upright to accommodate the hardware as shown.  
*Note drill holes for 1/2" hardware.*
5. Spray paint expose hardware to prevent rusting.



**FIGURE: 8**

# Semi-Permanent Installation

## Ground Sleeve:

1. Rotate the assembled foul pole to align the wing panel to the foul line in accordance with Figure 1.
2. Drill a 1/2" hole in the foul pole at the top of the sleeve, to accommodate the anti-rotation rod.
3. Install the 1/2" thread rod and flange nuts thru the sleeve (figure 9).

