

# TABLE OF CONTENTS

---

- Introduction.....1
- General Safety Rules.....2
- Symbols.....3
- Technical Specifications.....4
- User Instructions.....5
- Maintenance.....9
- Customer Service Information.....9

## INTRODUCTION

---

The Rogers Athletic Powerblast has been designed and manufactured with safety, performance, and dependability as top priorities, making it easy to operate and maintain.

The care you give your Powerblast will greatly determine your satisfaction with its performance and service life. Careful study of this manual is encouraged to obtain a thorough understanding of your new Powerblast and its functions and maintenance.

If your manual should become lost or destroyed, Rogers Athletics will gladly provide you with a new copy. Should you require additional information or assistance, please feel free to contact us at 1-800-457-5337.

BECAUSE ROGERS ATHLETICS MAINTAINS AN ONGOING PROGRAM OF  
PRODUCT DEVELOPMENT AND IMPROVEMENT, WE RESERVE THE RIGHT  
TO MAKE IMPROVEMENTS IN DESIGN OR CHANGES IN SPECIFICATIONS  
WITHOUT INCURRING ANY OBLIGATIONS TO INSTALL THEM ON UNITS  
PREVIOUSLY SOLD.

# GENERAL SAFETY RULES

---



## **WARNING!**

### **READ AND UNDERSTAND ALL INSTRUCTIONS.**





Failure to follow all instructions listed below may result in serious personal injury.

---

## **SAVE THESE INSTRUCTIONS**

- **Supervision of athletes while using the equipment is recommended.** Horse play such as climbing on the machine or using the machine for unintended purpose can result in injuries.
- **Athletes should be oriented in the proper use of the equipment.**
- **Athletes should be properly fit to engage in a workout regimen.** Obtaining a medical exam prior to beginning any training program is recommended. If an athlete feels faint, dizzy, or experiences pain at any time while exercising, they should stop exercising and consult a physician.
- **Inspect equipment prior to use.** DO NOT use if it appears damaged or inoperable.
- **This Product Information Packet is an integral part of this machine.** Save these instructions. If they are lost or damaged or if you would like another copy, a copy can be downloaded from [www.RogersAthletic.com](http://www.RogersAthletic.com)
- **Reading the Product Information Packet is recommended.** Failure to read this Packet is considered a misuse of this equipment.
- **Warning labels are an integral part of this equipment.** Become familiar with all caution/warning labels and never cover or deface caution/warning labels.
- **Deploy the equipment allowing sufficient room for safe access to the machine, adequate room for the coaches to stand and to ensure that the machine or players do not collide with a wall, another machine, or other players through the entire training exercise.**
- **Unit is designed for training multiple offensive and defensive drills with proper technique.** Do not use Powerblast for anything other than its approved purpose.
- **Always wear a helmet when training with the Powerblast.**
- **Equipment is designed for use by one person per unit at a time.** Keeping other athletes and spectators away from the machines during use is recommended.
- **Design and execute training drills to avoid players from attempting to run through the same gap in the unit simultaneously.** Colliding players could come in contact with the unit and/or connecting links resulting in an injury.
- **When not in use, store this equipment in a secure controlled area.** Unsupervised and/or inappropriate use of this equipment could result in serious injury.
- **Do not inflate arms with more than 20 psi. over inflation of arms could result in serious injury**

# SYMBOLS

	<p><b>Safety Alert:</b> Precautions that involve your safety</p>
<div style="border: 1px solid black; padding: 5px;"> <div style="background-color: orange; color: white; text-align: center; padding: 2px;"><b>⚠ WARNING</b></div> <div style="display: flex; align-items: center;">  <div> <p><b>Store in secure area.</b> Inappropriate use of this equipment could result in serious injury.</p> </div> </div> </div>	<p><b>Store this equipment in a secure, controlled area:</b> Unsupervised and/or inappropriate use of this equipment could result in serious injury.</p>
<div style="border: 1px solid black; padding: 5px;"> <div style="background-color: yellow; color: black; text-align: center; padding: 2px;"><b>⚠ CAUTION</b></div> <div style="display: flex; align-items: center;">  <div> <p><b>Pinch Point.</b> Keep Hands And Fingers Clear</p> </div> </div> </div>	<p><b>Pinch Point Symbol:</b> Failure to keep hands away from pinch points will result in personal injury</p>
<div style="border: 1px solid black; padding: 5px;"> <div style="background-color: yellow; color: black; text-align: center; padding: 2px;"><b>⚠ CAUTION</b></div> <div style="display: flex; align-items: center;">  <div> <p>Stay clear of equipment when in use.</p> </div> </div> </div>	<p><b>Stay Clear Warning Label:</b> Stay clear of field equipment when it's in use.</p>
<div style="border: 1px solid black; padding: 5px;"> <div style="background-color: yellow; color: black; text-align: center; padding: 2px;"><b>⚠ CAUTION</b></div> <div style="display: flex; align-items: center;">  <div> <p>Avoid Injury. Do not climb.</p> </div> </div> </div>	<p><b>Do Not Climb:</b> To reduce risk of injury, do not climb on the field equipment.</p>

# ROGERS ATHLETIC FIELD EQUIPMENT SPECIFICATIONS

## POWERBLAST

	Height (in)	Width (in)	Length (in)	Weight (lbs)
Powerblast				
12 Arm	88 7/8	63 3/4	78 5/8	591
16 Arm	88 7/8	63 3/4	78 5/8	657
20 Arm	88 7/8	63 3/4	78 5/8	704
w/ Dummy				
12 Arm	100 3/4	63 3/4	131 1/8	776
16 Arm	100 3/4	63 3/4	131 1/8	842
20 Arm	100 3/4	63 3/4	131 1/8	889
w/ Powerline Sled				
12 Arm	88 7/8	75	121 3/4	775
16 Arm	88 7/8	75	121 3/4	825
20 Arm	88 7/8	75	121 3/4	896
w/ Dummy & Sled				
16 Arm	100 3/4	75	174	1010
20 Arm	100 3/4	75	174	1081
Youth Powerblast				
12 arms	87	58	78 5/8	591
12 arms w/ dummy	87	58	131 1/8	776

### Construction, Finish, and Hardware

- Constructed of ASTM specified steel.
- Baked-on powder coat finish
- Galvanized steel tube
- Zinc-plated hardware
- Phenolic wheels

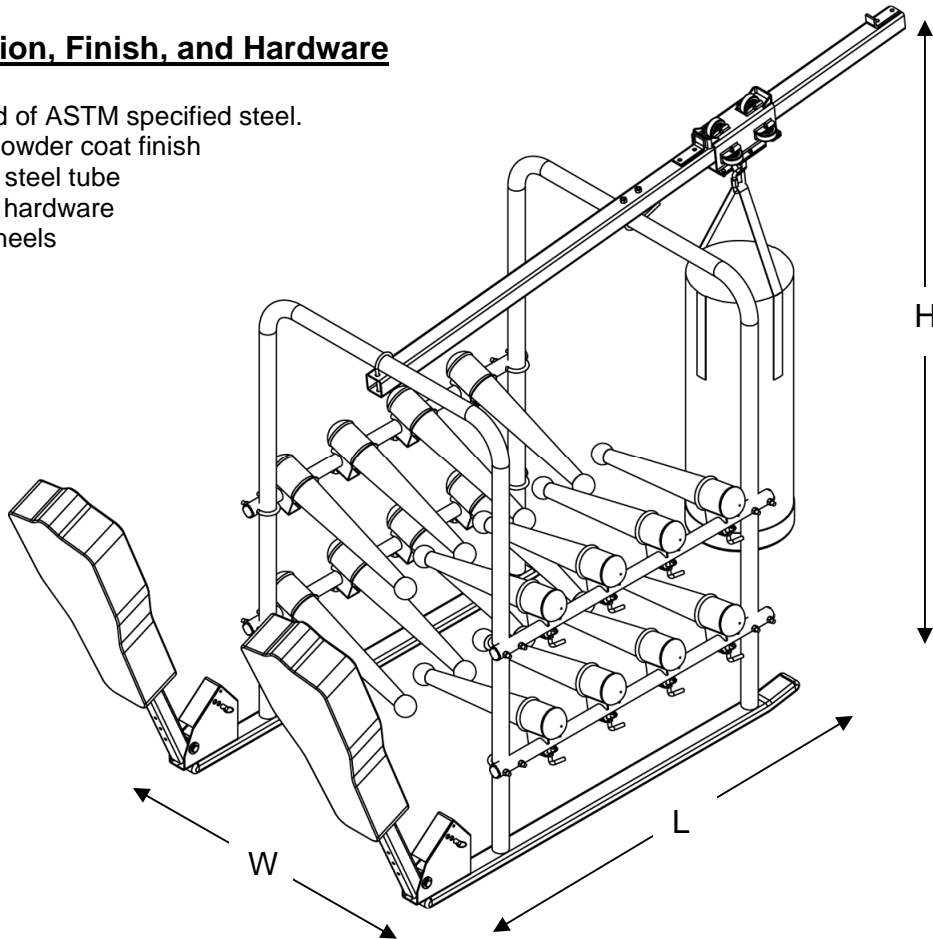

1

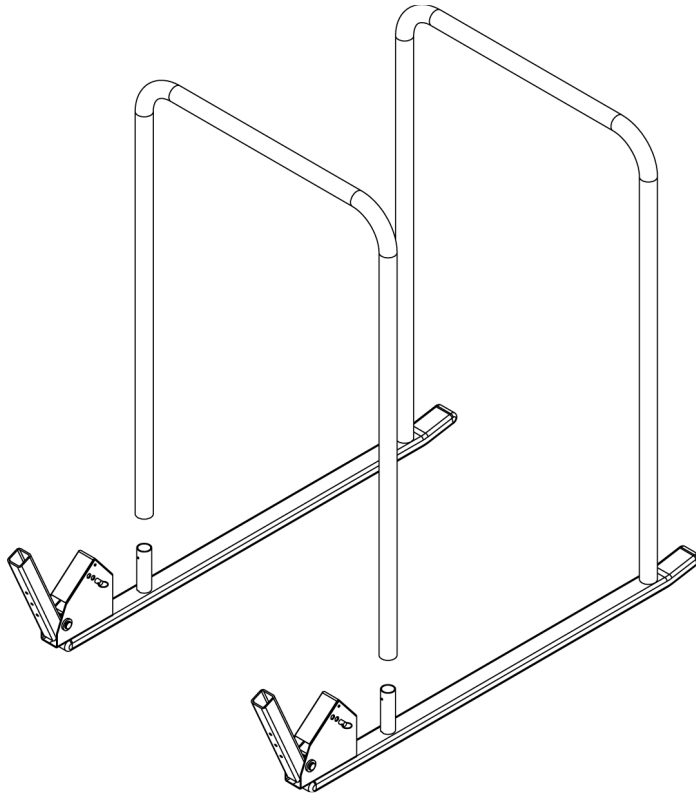

Begin by setting runners roughly 50" apart, and slide the frame tubes onto the runners' locator tubes.

2

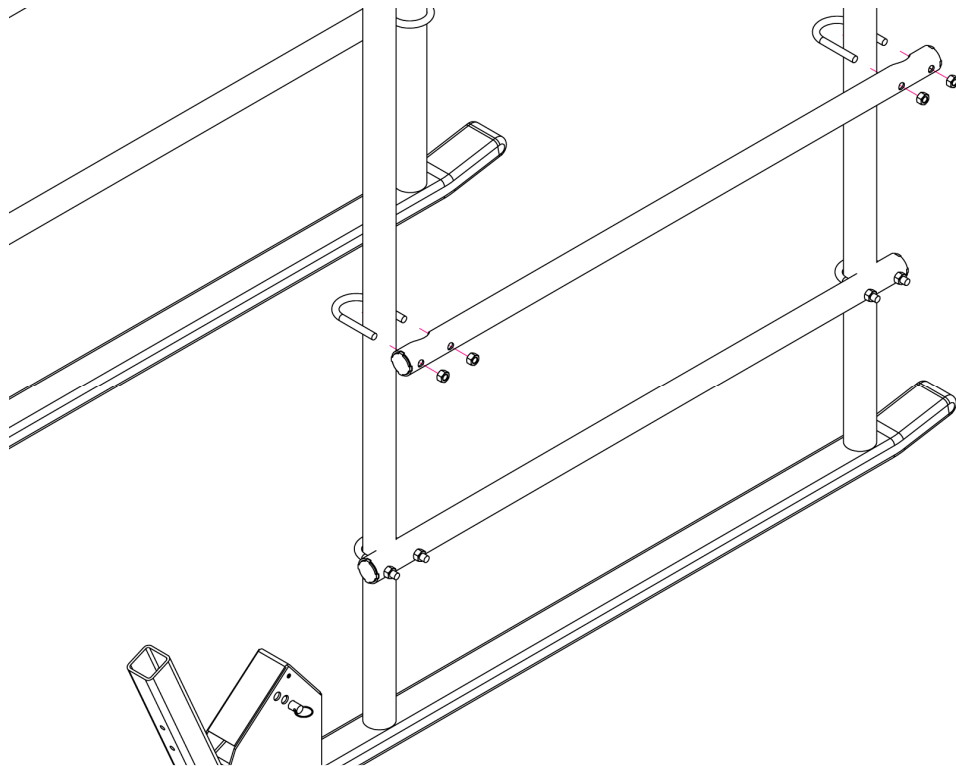

Attach the Powerblast arm carrier tubes with 5/8" u-bolts and nuts (15/16" wrench). Place them near the desired height before tightening.

3

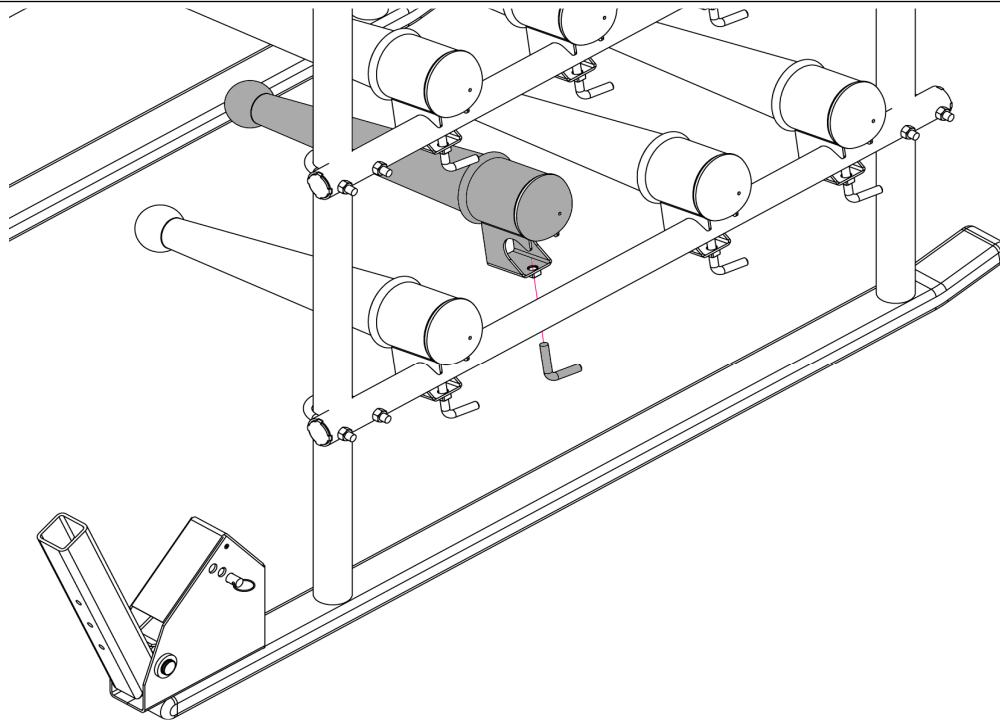

Install Powerblast arms by sliding the bracket over the carrier tube and tightening the pinch bolt when you have the arm at your preferred angle. Adjust height and angle of arms as necessary. Inflate arms to 10 to 15 psi. Arms can be deflated or inflated to change difficulty. Recommended air pressure for arms is 10 to 15 psi. Remove Arms when not using and store out of direct sun.

4

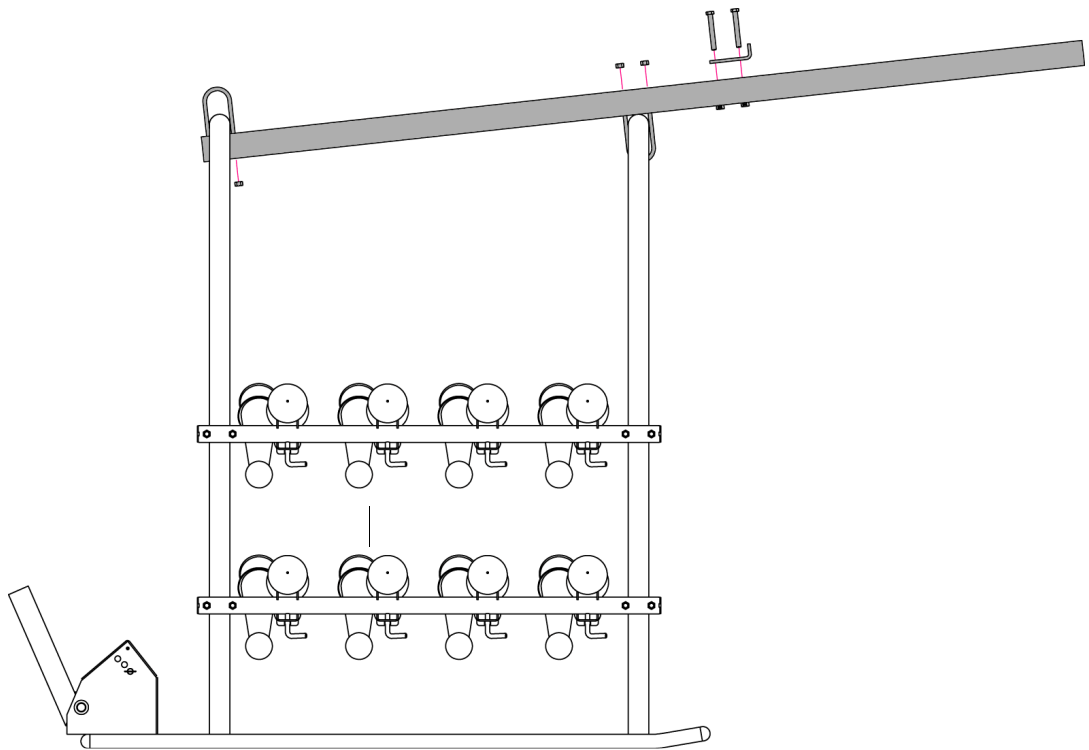

If your Powerblast is equipped with the hanging dummy, install it as shown with 1/2" dia U-bolts and nuts (15/16 wrench). Also attach the forward trolley stop with 5/8" bolts and nuts.

5

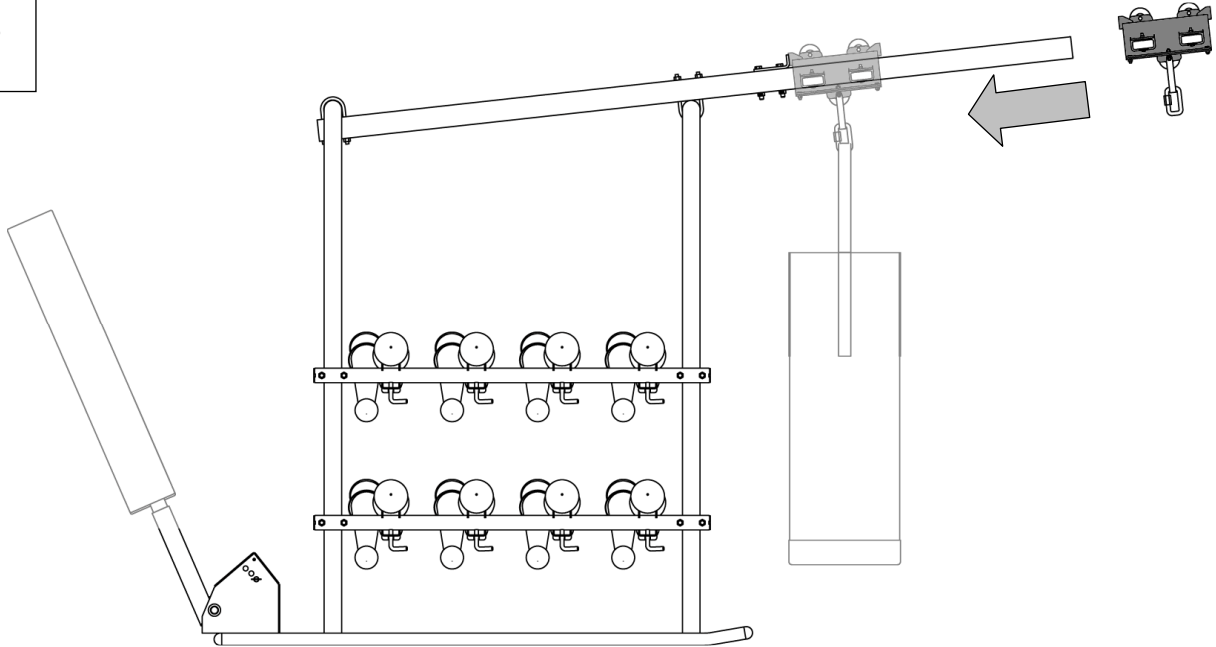

Install the hanging dummy Trolley on the Trolley Runner as shown, with two wheels on top and one on bottom. Dummy can now be hung from the Trolley, and pads added to the sled.

6

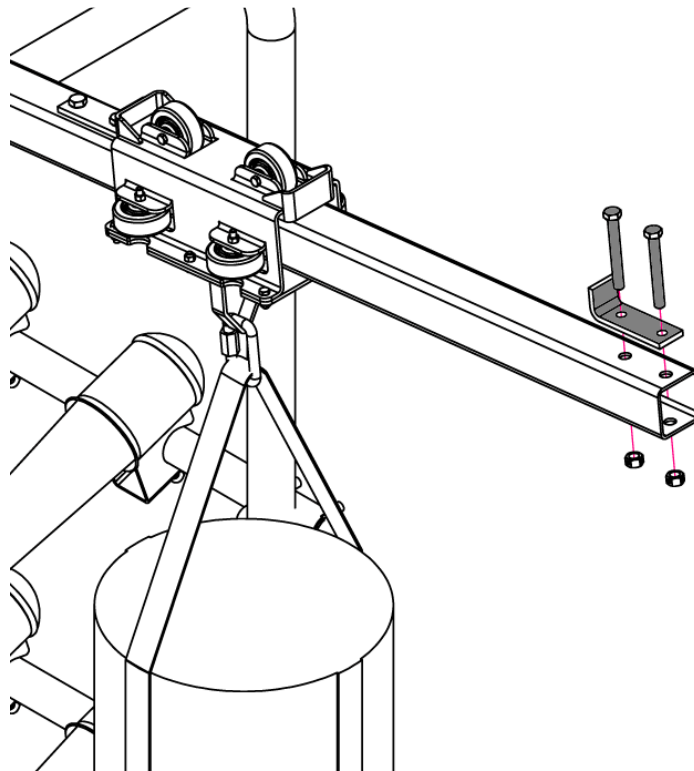

Finish assembly by installing the rear bump stop on the Trolley Runner. Use two 5/8 x 5" bolts and nuts.

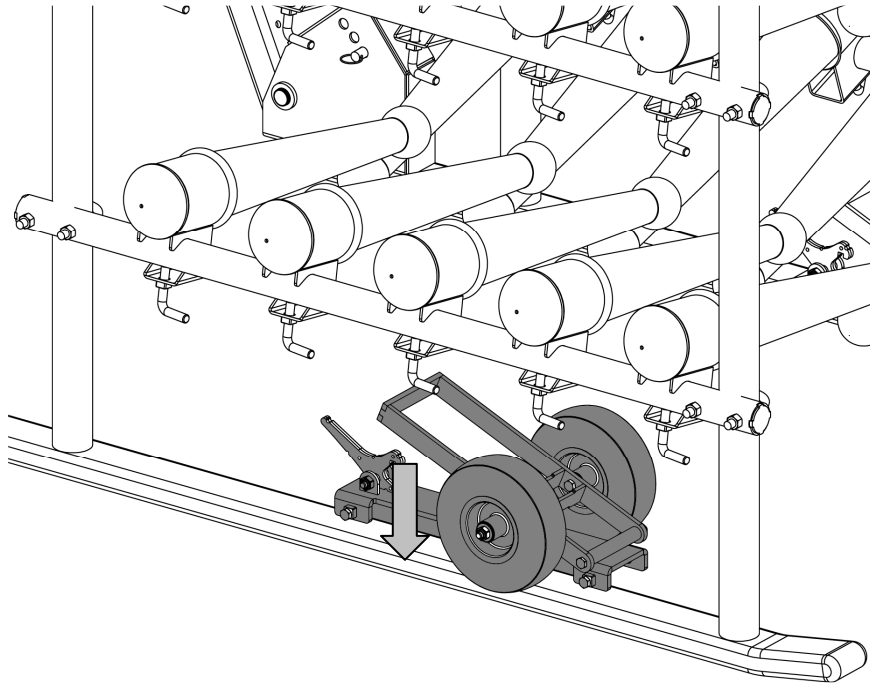
**7****Optional Wheel Kit**

Install the wheel kit by placing the bracket over the runner tube with the wheels unlatched from the bracket and tighten pinch bolts (3/4" wrench). Repeat for each runner tube.

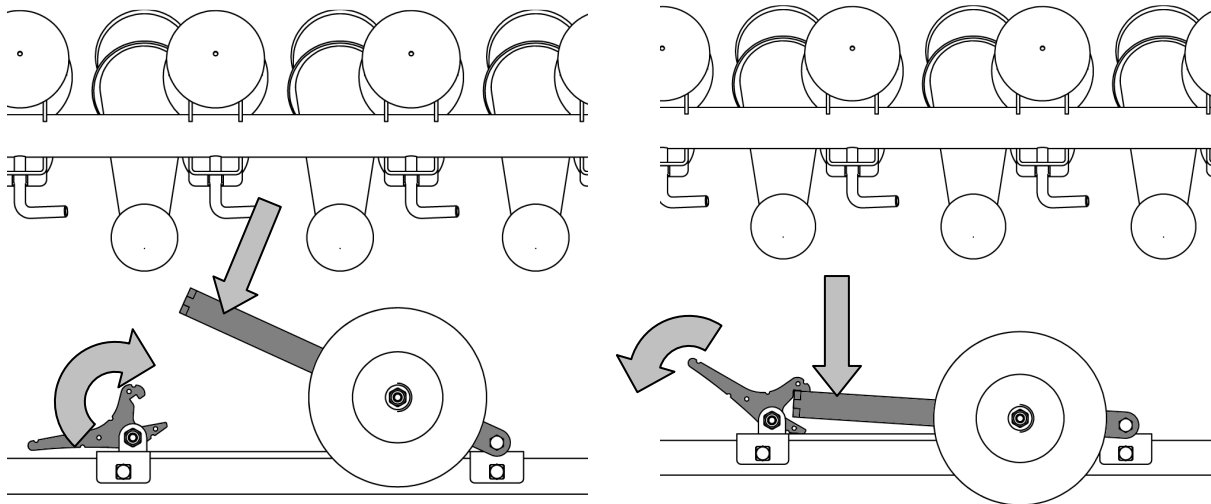
**8****LOCK****UNLOCK**

**Using the wheel kit:** Lock the wheels in place by pushing down or standing on the wheel frame until the latch catches. Unlock the wheels by standing on the wheel frame and giving a quick push down to release the latch.



# MAINTENANCE

---



## **WARNING!**

### **READ AND UNDERSTAND ALL MAINTENANCE PROCEDURES.**

Failure to follow all procedures listed below may cause serious injury and a decrease in the equipments functional existence.

---

- **Frequently check to see that all bolts are securely fastened.**
- **Touch up paint can be used to cover any scratches or blemishes sustained through use.**
- **Never cover or deface the warning labels.**
- **A silicone base lubricant may be used on moving parts to maintain proper function.**
- **Replace any worn or damaged equipment with genuine Rogers Athletic parts.** Failure to do so may result in unsafe equipment and/or personal injury.

# CUSTOMER SERVICE

---

For parts or service contact Rogers Athletic Company. When ordering parts be sure to provide all relevant information available including the name and part number of the equipment purchased. This information is located on the cover of this product information package. Customer service hours are Monday through Friday from 8:00 a.m. to 5:00 p.m. Eastern Standard Time. Customers can phone (989) 386-2950 or toll free at 1-800-457-5337. Fax toll free at (888) 549-9659 or mail:

Rogers Athletic Company  
3760 W. Ludington Drive  
Farwell, Michigan 48622