

6

Adjust the rear brackets with the rear aluminum Roof using two 1/4" x 1" bolts with nuts and washers then use two 30mm bolts into the perforationes in the roll cage. (As it is shown in the image)

7

Make sure step 1 through 6 are completed and proceed to tighten the full assembly of the aluminum roof.

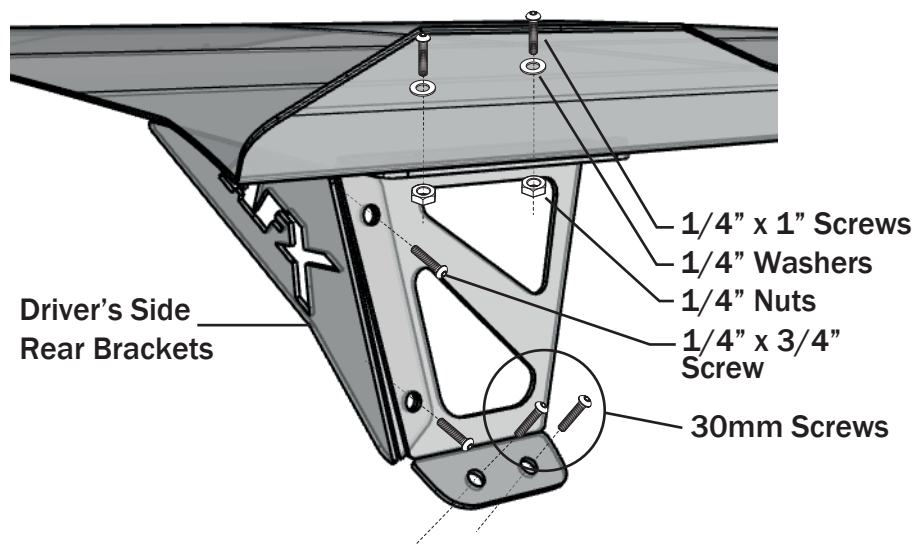

For technical support , please write us to:
support@afxmotorsports.com or call us at:
Ph. 956-242-6521

HAVE FUN AND A SAFE RIDE!



www.afxmotorsports.com

4610 Modern Lane, Laredo, TX 78041 Ph. 956-242-6521

THIS PRODUCT IS FOR OFF ROAD USE ONLY

ALUMINUM ROOF INSTALLATION MANUAL

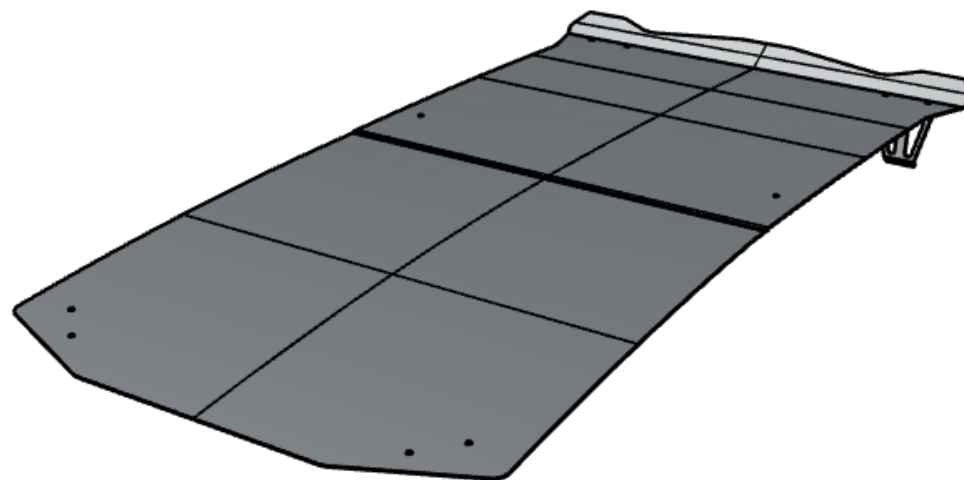

**RZR TURBO S
4 SEATS**

TEC048

THANK YOU!

FOR PURCHASING AT AFX MOTORSPORTS



HOW TO INSTALL

Pieces included:

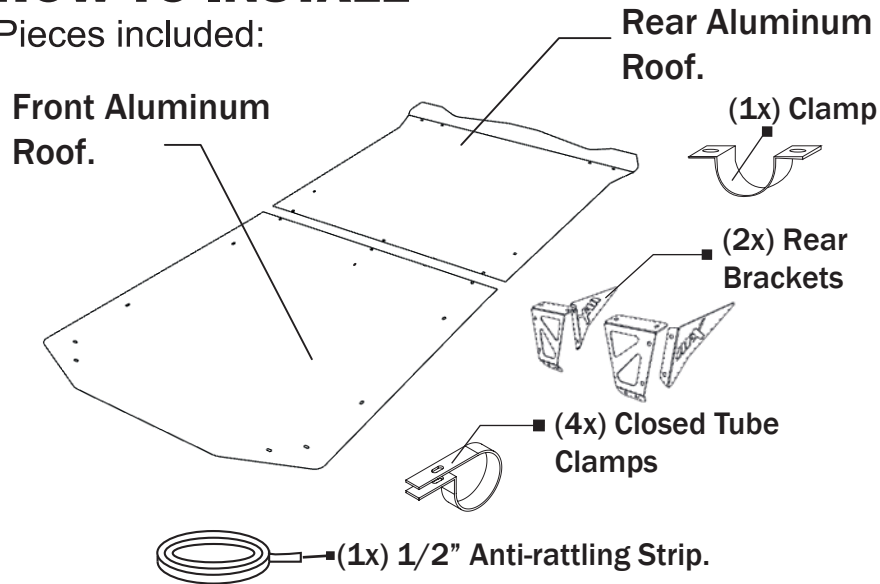

- (8x) 6 x 30mm screws
- (15x) 1/4" x 1" screws
- (4x) 1/4" X 3/4" screws
- (27x) 1/4" washers
- (19x) 1/4" nuts

Tools Needed (Not Included)

- 5/32" Allen Key.
- 7/16" or 14 mm Combination Wrench.

Liability Statement

AFX Motorsports products are designed to best fit user's ATV/UTV under stock conditions. Adding, modifying, or fabricating any factory or aftermarket parts will void any warranty provided by AFX Motorsports and is not recommended. AFX Motorsports products could interfere with other aftermarket accessories. If user has aftermarket products on machine, contact AFX Motorsports to verify that they will work together. Although AFX Motorsports has thousands of satisfied customers, user should be aware that installing bumpers, rock sliders, spare tire carriers, etc. will change the ride of machine and may increase maintenance and part wear. Operating any off-road machine while, or after, consuming alcohol and/or drugs increases risk of bodily harm or death. No warranty or representation is made as to this product's ability to protect user from severe injury or death. AFX Motorsports urges operators and occupants to wear a helmet and appropriate riding gear at all times. By purchasing and installing AFX Motorsports products, user agrees that should damages occur, AFX Motorsports will not be held responsible for loss of time, use, labor fees, replacement parts, or freight charges. AFX Motorsports, nor any 3rd party, will not be held responsible for any direct, indirect, incidental, special, or consequential damages that result from any product purchased from AFX Motorsports. The total liability of seller to user for all damages, losses, and causes of action, if any, shall not exceed the total purchase price paid for the product that gave rise to the claim. AFX Motorsports will warranty only parts provided by AFX Motorsports. Any damage or problems with OEM housings, bearings, seals, or other manufacturers' products will not be covered by AFX Motorsports. AFX Motorsports parts and products are not warranted if item was not installed properly, misused, or modified.

- 1** In case of having the OEM Plastic Roof: Uninstall the original plastic roof of the vehicle, removing the screws located on the rear and front part.
- 2** Install the anti-rattling strip provided in the middle of the rollcage tubes, where the roof will be placed.
- 3** Place the rear roof in position, installing the bolts with the washers and nuts, as it shown in the image. (do not thighten yet)
- 4** Place the second part of the roof, aligning the holes with the bolts supplied. As it is shown in the image.
- 5** Use the 4 tube clamps in order to tight both parts of the roof on the middle bar of the roll cage. Use bolts washer and nuts as well, as it is shown in the image.

