

FIL FILAMENT HID

DESCRIPTION

HTM Lighting Solutions High Lumen Filament LED lamps replicate the traditional design of HID Metal Halide and High Pressure Sodium lamps while providing significant energy savings. Unlike Corn Cob Style LED Lamp, HTM Lighting Solutions High Lumen Filament LED Lamps contain LED filament rods that are powered by using a glass insulated circuit, similar to traditional lamps. Our filament HID replacement lamps come in the traditional ED23, ED28, and ED37 shapes, perfect upgrade option for commercial applications including post tops, bollards, high bays and wall packs. The lamps are Ballast Bypass, Enclosed Fixture Rated, with 360° Omni Directional with Highest LPW (200LPW) backed by the best 5 year warranty in the market.

APPLICATIONS

Warehouses, Parking Structures, Large Retail Facilities, Large Public Area, Pathways, Industrial Lighting

FEATURES

- ETL, cETL Listed
- DOE Qualified
- 200LPW
- Color Temp: 3000K, 4000K, 5000K
- Highest 200LPW (lumens per watt)
- Voltage: 120-277V
- Power Factor: >0.9
- CRI: >80
- Surge Protection: 2KV
- Operating temperature: -4°F - 113°F
- Instant on / Uniform and consistent color
- Up to 70% energy savings
- Beam Angle: 360°
- Direct Replacement traditional HID Metal Halide
- Material : Glass
- 5 Year Warranty
- 35,000 hrs rated average life

SAMPLE NUMBER LED20FHID/ED23.5/EX39/830

STYLE	WATTAGE	SERIES	SHAPE	BASE	CRI	COLOR TEMP
LED	20	FHID	ED23.5	EX39	8	30
LED Lighting	20 Watt	Filament HID	ED23.5 ED28 ED37	EX39	320+ Lumens	CRI 90 3000K



PROJECT:

SCHEDULE: **DATE:**

PREPARE BY:

NOTES:



Rated Life Hours 35,000
Warranty 5 Years

Ballast must be Bypassed. Line Voltage Only.

ACCESSORIES



ORDERING

Watts (W)	Ordering Code	Description	CCT (K)	Lumens (Lm)	Base	Equiv. Wattage (W)	LPW
20	4620	LED20FHID/ED23.5/EX39/830	3000K	4,000	EX39	75	200/LPW
20	4621	LED20FHID/ED23.5/EX39/840	4000K	4,000	EX39	75	200/LPW
20	4622	LED20FHID/ED23.5/EX39/850	5000K	4,000	EX39	75	200/LPW
25	4623	LED25FHID/ED28/EX39/830	3000K	5,000	EX39	100	200/LPW
25	4624	LED25FHID/ED28/EX39/840	4000K	5,000	EX39	100	200/LPW
25	4625	LED25FHID/ED28/EX39/850	5000K	5,000	EX39	100	200/LPW
30	4626	LED30FHID/ED28/EX39/830	3000K	6,000	EX39	150	200/LPW
30	4627	LED30FHID/ED28/EX39/840	4000K	6,000	EX39	150	200/LPW
30	4628	LED30FHID/ED28/EX39/850	5000K	6,000	EX39	150	200/LPW
40	4629	LED40FHID/ED28/EX39/840	4000K	8,000	EX39	250	200/LPW
40	4630	LED40FHID/ED28/EX39/850	5000K	8,000	EX39	250	200/LPW
40	4631	LED40FHID/ED28C/EX39/840	4000K	8,000	EX39	250	200/LPW
40	4632	LED40FHID/ED28C/EX39/850	5000K	8,000	EX39	250	200/LPW
55	4633	LED55FHID/ED37/EX39/840	4000K	11,000	EX39	400	200/LPW
55	4634	LED55FHID/ED37/EX39/850	5000K	11,000	EX39	400	200/LPW

ACCESSORIES



Adapter E26 to EX39 Lamp
 P10544 ADP-E26-EX39
 (Adapter for E26 Socket to E39/EX39 Lamp)



Adapter EX39 to E26 Lamp
 P10545 ADP-EX39-E26
 (Adapter for E39/EX39 Socket to E26 Lamp)

WIRING DIAGRAM

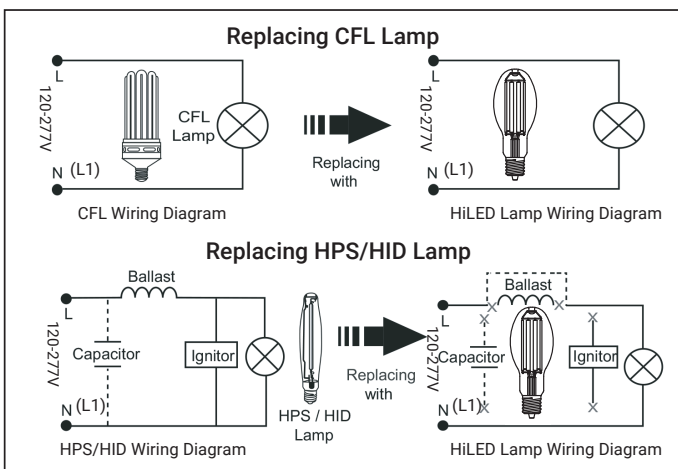

Ballast must be Bypassed. Line Voltage Only.

LAMP COMPARTMENT DIMENSION

Model No.	Type of Recessed Luminaires and Min. Lamp Compartment Dimension
ED23.5 (20W)	8.50" x 6.02" x 6.02" (216mmX153mmX153mm)
ED28 (25/30/40/45W)	14.00" x 8.03" x 8.03" (356mmX204mmX204mm)
ED37 (45/55/65W)	15.35" x 16.53" x 7.48" (390mmX420mmX190mm)
ED37 (85W)	13.74" x 16.97" x 16.97" (349mmX431mmX431mm)

DIMENSIONS

E23.5 Lamp
20 Watt: 0.37-lbs

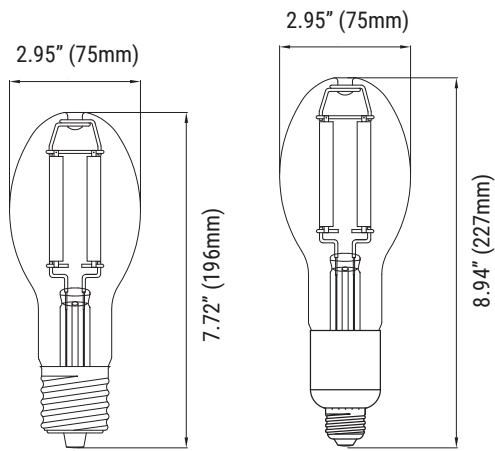

E28 Lamp
25 Watt: 0.37-lbs
30 Watt: 0.44-lbs
40 Watt: 0.46-lbs

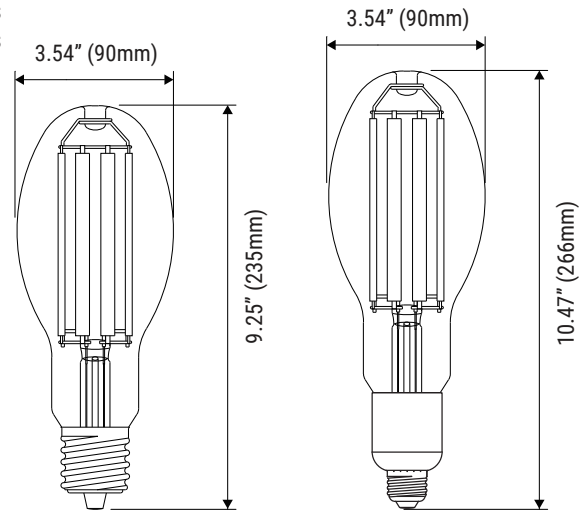

E37 Lamp
55 Watt: 0.62-lbs

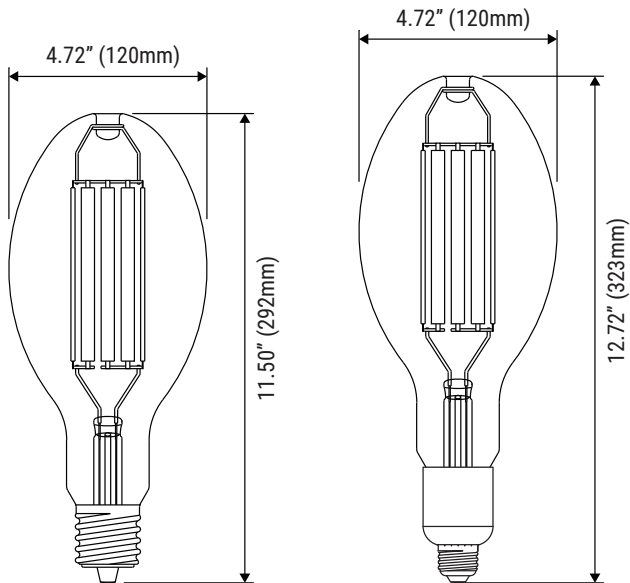

P10544 ADP-E26-EX39

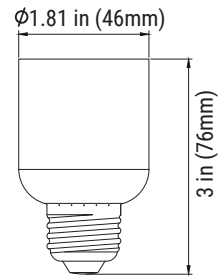

P10545 ADP-EX39-E26

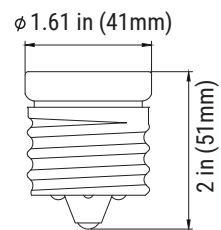

PACKAGE

Case Qty 10 pcs

