



# HITCH INSTALLATION INSTRUCTIONS

MAKE: SUBARU      YEARS: 2015 - 2019      MODEL/TRIM: OUTBACK (BS CHASSIS)

www.stealthhitches.com      833•694•4824

RACK RECEIVER KIT#: **SHR66005**

COMPATIBLE WITH TOW KIT: **SHT25028**

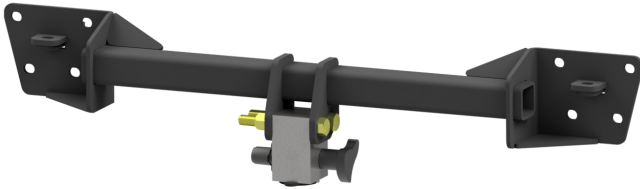

**2" RACK RECEIVER MAXIMUM PAYLOAD: 350 LBS**  
**MAXIMUM TOW RATING: 3500 LBS**  
**MAXIMUM TONGUE WEIGHT: 350 LBS**

## UNDER VEHICLE TRIMMING:

HEAT SHIELD: **NO**  
 FASCIA: **YES**  
 GRAVEL GUARD TRIMMING: **NO**



**READ ALL INSTRUCTION WARNINGS AND LABELS**



**NO WELDING, METAL DRILLING OR VISIBLE TRIMMING REQUIRED**

### PARTS SUPPLIED WITH RACK RECEIVER KIT:



LATCH BLOCK



(2) BOLTS  
5/8" - 11 x 5"



(2) 5/8"  
NYLOCK NUTS



2" RACK RECEIVER

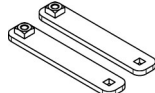

(2) ANCHOR STRAPS



(2) 7/16" CARRIAGE BOLTS



(2) 7/16" SERRATED FLANGE NUTS



(2) 1/2" LOCK WASHERS



(2) 1/2" FLAT WASHERS



(2) BOLTS  
1/2" x 1-1/2"

### ADDITIONAL PARTS FOR TOW KIT:

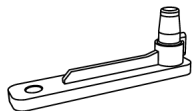

BALL MOUNT  
3" RISE, SHORT



CHAIN HOOKS



2" BALL

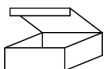

PASSIVE WIRING KIT BOX

### TOOLS REQUIRED:



15/16" OPEN END WRENCH



14mm DEEP WELL, 10mm, 11/16", 3/4", & 15/16" SOCKETS



TORQUE WRENCH

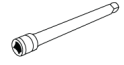

SOCKET EXTENSION



SAFETY GLASSES



RATCHET



FLASHLIGHT



PHILLIPS HEAD SCREWDRIVER



PLASTIC PRY TOOLS



90 DEGREE PICK



DREMEL TOOL



FILE

### ADDITIONAL TOOLS FOR TOW KIT:



MULTIMETER



STRIPPER/CRIMPING TOOL



DRILL & 3/8" BIT



SILICONE



SIDE CUTTERS

# <THESE INSTRUCTIONS MUST BE GIVEN TO THE END USER>

**NOTICE:** Installation of Stealth products may or may not require the addition of a wiring harness to the vehicle.

- The Rack Receiver only product does not require adding a wiring harness.
- The Rack Receiver plus Tow Kit requires the addition of a "Passive" wiring harness to the vehicle. The passive harness "reads" the output of the vehicle's lights and translates the signals to the trailer without being connected to the vehicle computer.

**INSTALLATION NOTE:** In most instances, these instructions will only outline disassembly of vehicle components. Re-installation of components will require the installer to retain vehicle hardware and work through disassembly instructions in reverse order. When installation is complete, double check that all vehicle components have been replaced and are secured.

## IMPORTANT SAFETY NOTICE FOR STEALTH HITCH INSTALLERS AND CUSTOMERS.

Read all installation and operating instructions along with all labels before installing or using this product. Do not perform any installation or towing procedures without fully understanding the correct tools and actions for all steps. Call for support if needed.

### **⚠ WARNING** Failure to comply with the safety information in these instructions could result in serious injury or death.

- ⚠ Do not modify this product in any manner. Doing so could alter its integrity and lead to a loss of attachment between the trailer and the tow vehicle.
- ⚠ Adding Stealth hitch components to the chassis of any vehicle can be hazardous. There is potential for unexpected combustion of fuel, electric shock, burns, shifting or falling of unstable vehicle, damage to vehicle, injury from tool usage and many other hazards. This installation must be completed by someone who is aware of the hazards involved. This person must be knowledgeable of proper safety procedures for a vehicle modification of this nature, and for usage of the equipment required to perform the installation.
- ⚠ Without proper knowledge, towing can be a dangerous activity. Understand all the risks involved with towing before proceeding. For information on towing safety, see "**The Trailer Handbook: A Guide to Understanding Trailer and Towing Safety**" from the National Association of Trailer Manufacturers, [www.NATM.com](http://www.NATM.com) and your trailer and tow vehicle manufacturer's owner's manual.
- ⚠ Do not exceed tow or tongue rating of coupler, tow or tongue rating of hitch, or tow or weight ratings of tow vehicle or trailer. See vehicle and trailer manufacturer information for ratings. Exceeding these ratings may cause damage to towing components or loss of attachment between the trailer and vehicle.
- ⚠ While installation is being performed, check for signs of damage or excessive corrosion. Do not install hitch components over vehicle parts that are broken or have compromised structural integrity.
- ⚠ This product was designed to fit vehicles in their original, "as manufactured" condition. Compatibility with vehicles having replacement parts, or other modifications is not guaranteed. Inspect vehicle for modifications before installation of this product.
- ⚠ Some accessories, like the rack receiver, are not rated for towing. Do not use any accessories without proper knowledge of their use.
- ⚠ A visual inspection of the hitch should be performed before each use. Regularly check that all connections are secure, including those that secure the hitch to the vehicle. Check for cracks or damage to the hitch. Do not use the hitch if cracks or damage outside of normal wear is found. Using a hitch that has unsecure connections and/or cracks or damage could result in damage to the tow vehicle, trailer, towing components and loss of attachment between the tow vehicle and trailer.
- ⚠ Stealth hitches are not compatible with any weight distribution or sway control products. Adding additional products to the trailer or chassis which modifies the function of the Stealth hitch may cause hitch failure.

**NOTICE:** Installation of hitch requires removal of vehicle parts and interaction with vehicular electronics. Before installation, check the condition of body panels and note any locations where panels are not flush. Check the electronic functions of the vehicle, such as: headlights, taillights, turn signals, cameras, backup sensors, Parking Distance Controller (PDC), foot activated cargo access, etc. It is the responsibility of the installer to restore the fit and function of the vehicle

## GAIN ACCESS TO MOUNTING AREA



90 DEGREE PICK



10mm SOCKET



PHILLIPS HEAD SCREWDRIVER

1. Open the rear door of the vehicle. Locate the screw cap on each side of the door. Open the screw caps and remove (2) screws.



PLASTIC PRY TOOLS



PHILLIPS HEAD SCREWDRIVER

2. Locate the two plastic covers next to the rear taillights. Remove (2) plastic rivets from each cover. Pry the covers inward with a plastic pry tool to unclip cover and remove.



PHILLIPS HEAD SCREWDRIVER



10mm SOCKET

3. Remove (2) screws holding the taillights to the vehicle. Remove each taillight by sliding rearward. Unplug the taillights by turning the (2) light plugs counterclockwise. Unplug (1) light plug by pushing down on the clip and pulling the plug outward.





## GAIN ACCESS TO MOUNTING AREA CONTINUED



90 DEGREE PICK



PHILLIPS HEAD SCREWDRIVER

4. Inside the rear wheel well, behind the tire, locate the (3) screws and (1) rivet. Remove the rivet and screws. Remove the mud flap. Remove (2) plastic rivets in the fender well. Repeat step on other side of vehicle.

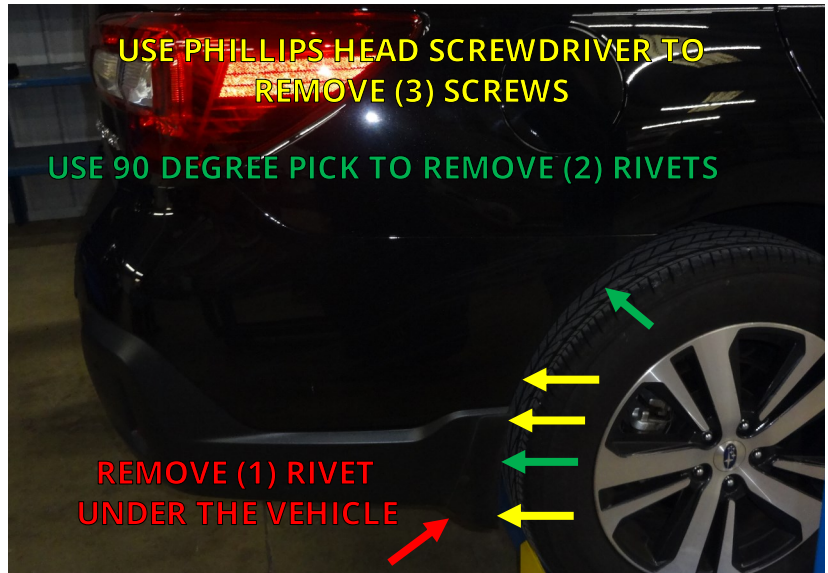

90 DEGREE PICK

5. Underneath the vehicle, remove (7) rivets from the bottom edge of the fascia.



PLASTIC PRY TOOLS

6. The rear fascia is clipped to the vehicle body above and behind the wheel wells. Pull outward on the top front of the rear fascia to expose a clip in the seam. With a plastic pry tool, push down on the exposed clip to disconnect. Continue to pull outward on the fascia and disconnect clips as they are exposed.

Continue applying outward and rearward pressure until all the clips are released. Repeat on other side of vehicle.





## GAIN ACCESS TO MOUNTING AREA CONTINUED

7. This step requires a partner. Slide the fascia rearward, keep the fascia close to the vehicle. On driver side of the vehicle unplug sensor plug, before removing fascia completely.

**NOTICE:** Carefully remove the fascia and place on a blanket or pad.

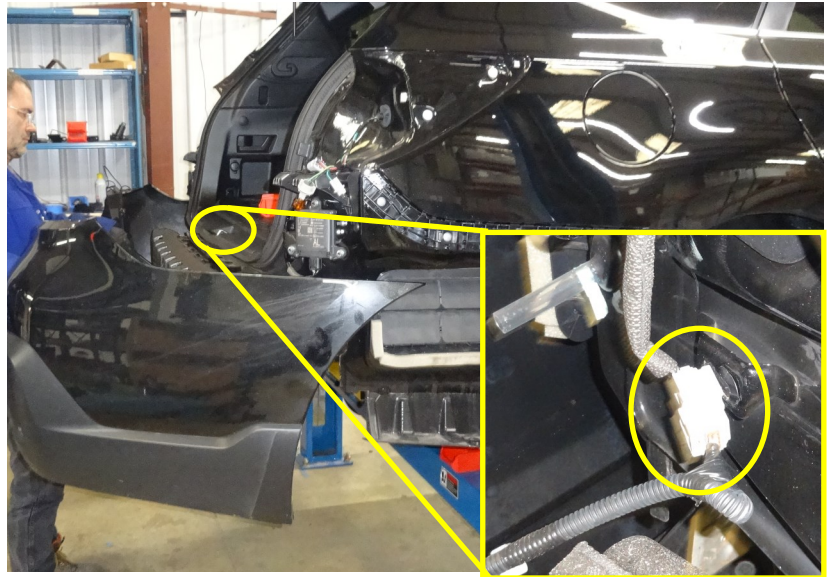

8. Remove the Styrofoam cover and discard.



14mm  
DEEP WELL  
SOCKET

9. Remove (8) nuts securing the factory reinforcement beam. Remove reinforcement beam. Save the nuts and reinforcement beam for reinstallation.

**USE 14mm SOCKET TO REMOVE (8) NUTS**



## INSTALL STEALTH HITCH FRAME

10. Remove the first rubber grommet from bottom of channel. Insert (2) supplied anchor straps into the chassis beams. The straps should be inserted weld nut end first, with the weld nuts facing up, as shown. Align the weld nuts with uncovered holes on bottom of chassis channels. Insert a 1/2" bolt, lock washer, and flat washer into each weld nut from underneath vehicle. Hand tighten hardware.



1 1/16" SOCKET



TORQUE WRENCH

11. Align the slots in the Stealth hitch frame with anchor straps and vehicle studs. Slide the hitch frame onto the anchor straps and vehicle studs. Insert 7/16" carriage bolts through the anchor strap and hitch frame. Fasten with 7/16" flange nuts. Torque the carriage bolts to 45 ft.-lbs.

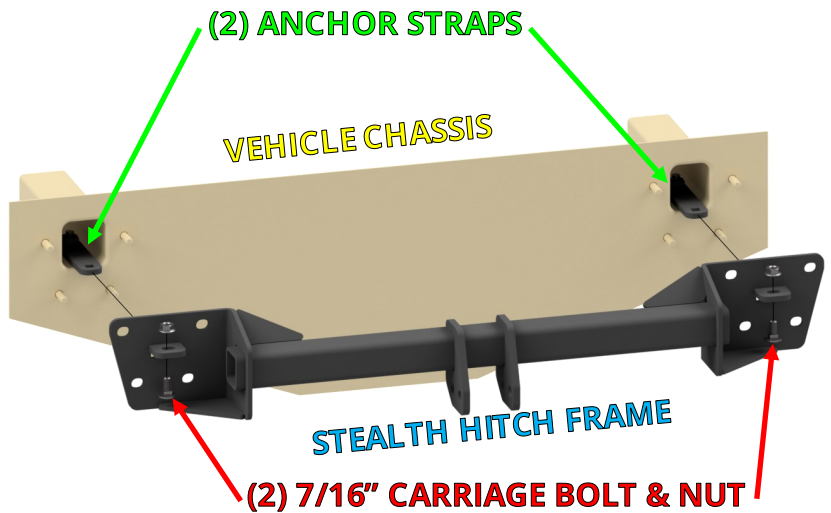

14mm DEEP WELL SOCKET



3/4" SOCKET



TORQUE WRENCH

12. Install the factory reinforcement beam on top of the Stealth hitch frame and center. Secure the hitch frame to vehicle with (8) factory nuts. Torque the (8) factory nuts to 45 ft.-lbs. Torque the (2) 1/2" bolts under the chassis channels to 100 ft.-lbs.

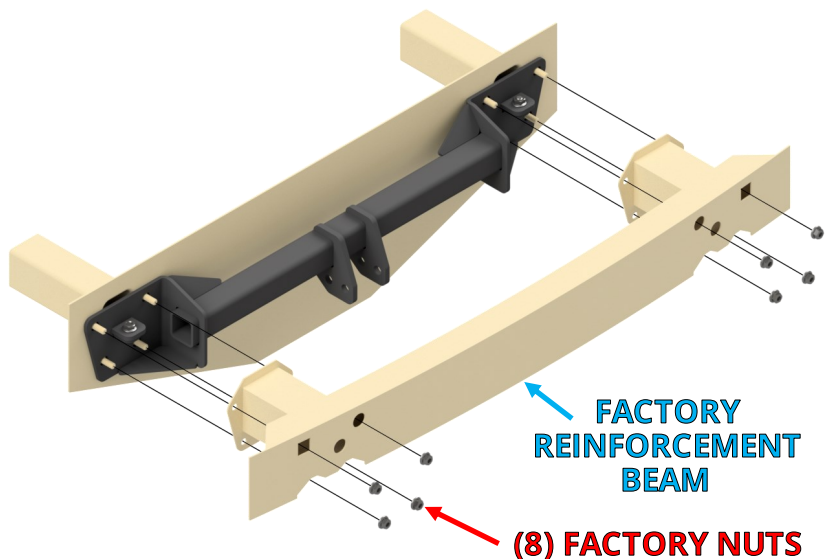

## MOUNT LATCH BLOCK



15/16"  
SOCKET



15/16" OPEN  
END WRENCH



TORQUE  
WRENCH

13. Installation of the latch block varies depending on which kit you are installing.

- **Rack Receiver Kit:** Install the latch block with (2) 5/8"-11 x 5" bolts and (2) 5/8" nylock nuts. Tighten each bolt to 150 ft.-lbs.
- **Tow Kit:** Install the latch block and (2) chain hooks with (2) 5/8"-11 x 5" bolts and (2) 5/8" nylock nuts. Tighten each bolt to 150 ft.-lbs.

**NOTICE:** Keys are packaged within the latch block, remove keys and store in safe location.

### RACK RECEIVER KIT INSTALL



### TOW KIT INSTALL

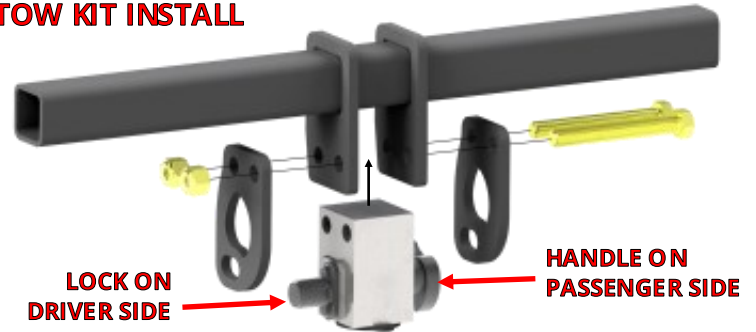

**IF INSTALLING A RACK RECEIVER KIT, SKIP TO STEP 29.  
IF INSTALLING A TOW KIT, CONTINUE TO STEP 14.**



## INSTALL PASSIVE WIRING KIT

#	DESCRIPTION	QTY
1	SUBARU 4-WAY HARNESS KIT <ul style="list-style-type: none"> <li>• CONTROL MODULE</li> <li>• 4-WAY PLUG &amp; WIRE</li> <li>• CABLE TIE - 6"</li> </ul>	1
2	ADHESIVE FOAM STRIP	2
3	CABLE TIE MOUNTS	2
4	MAGNETIC CABLE HOLDER	1
5	4-WAY FLAT CONNECTOR COVER	1
6	CABLE TIE - 14"	2



14. Locate the wiring kit box. Review the contents of the box against the list above to check for missing components. The passive wiring kit uses a control module to manage the functions of the trailer lighting. The module has an **"input"** side that receives power from the vehicle's wiring harness. The **"output"** side of the module delivers this information to the 4-way plug. The control module is connected to the vehicle's wiring harness as outlined in the next steps.

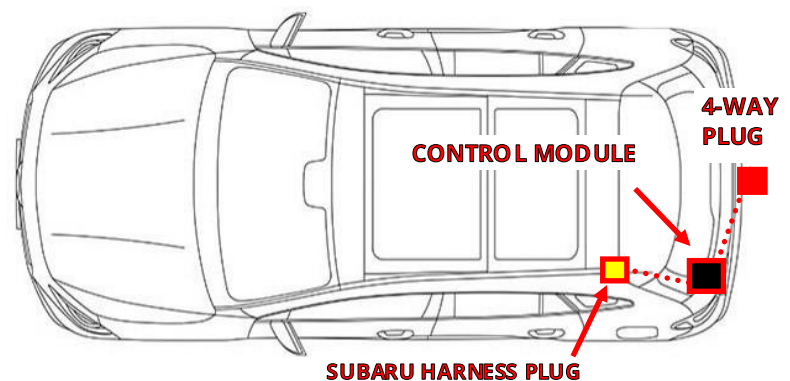
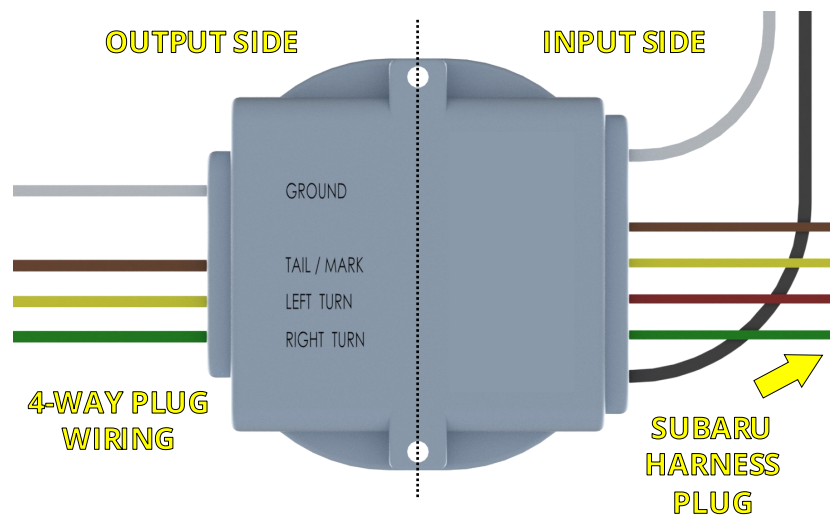

## INSTALL WIRING KIT CONTINUED

15. In the rear cargo area, remove the floor panel by lifting up and out. Place panel on blanket or safe area.



16. Remove the Styrofoam jack holder. Place holder on blanket or safe area.



17. On the driver side of the cargo area, remove the side floor panel by lifting up. Place panel on blanket or safe area.





## INSTALL WIRING KIT CONTINUED



18. Locate (2) plastic rivets holding the foam panel. Remove the rivets and foam panel. Place panel on blanket or safe area.

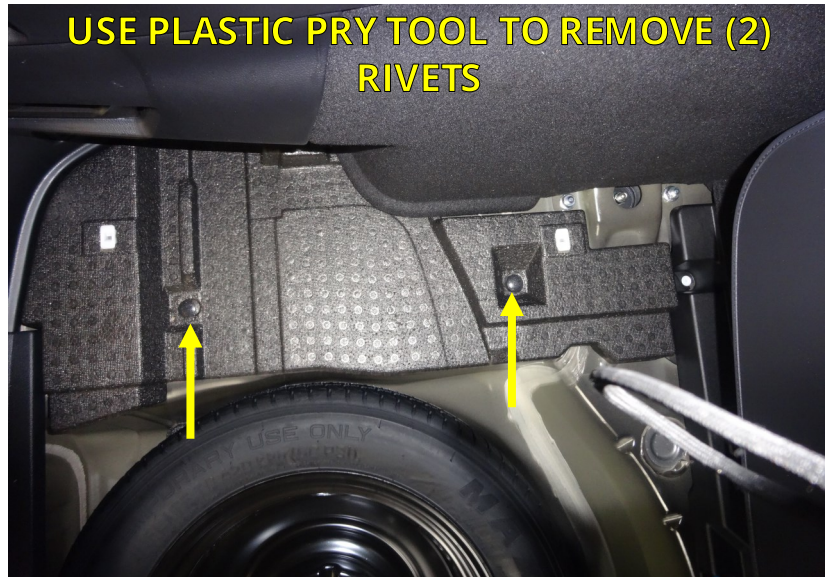

10mm  
SOCKET

19. Remove the driver side cargo anchor.



20. Let down the rear driver side seat. Lift up the panel to gain access to vehicle wiring plug.

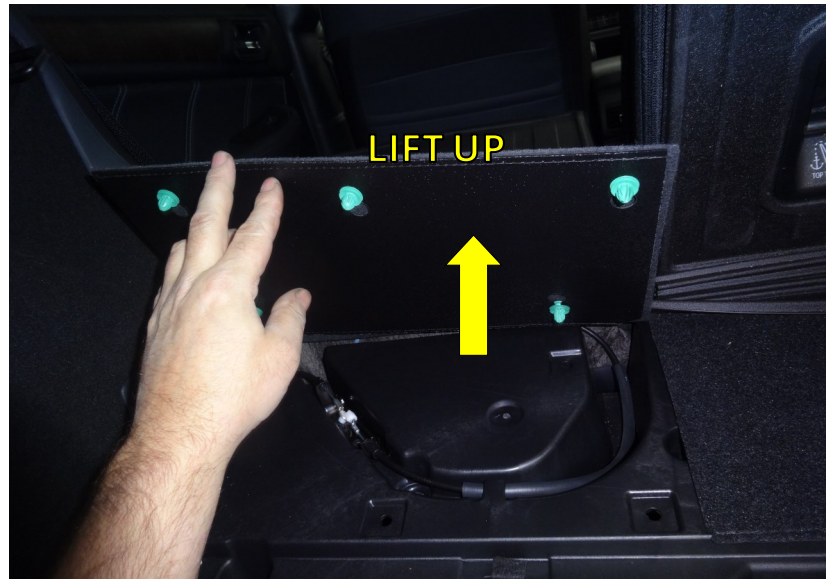



## INSTALL WIRING KIT CONTINUED

21. Locate the trailer harness plug under the driver panel, behind the rear seat. Retrieve the Subaru control module and plug the input side plug into the trailer harness plug.



22. Route the trailer wiring harness behind the driver side rear panel as shown. Replace the Styrofoam panel.



DRILL &  
3/8" BIT

23. Locate and remove the rubber grommet from the passenger side of rear wall. Drill a 3/8" hole in grommet. Retrieve the 4-way plug with wire. Pass the grommet over the wires so the plug will be on the outside of the vehicle. Thread the end of the wires into the hole and replace the grommet.



## INSTALL WIRING KIT CONTINUED

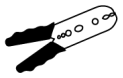

STRIPPER/  
CRIMPING  
TOOL

24. Match the colors and use a crimping tool to crimp the output wires to the harness inside the vehicle. Secure the output wires.

**NOTICE (OPTIONAL):** The butt splice connectors are heat shrink connectors. Apply heat to waterproof the connectors after crimping.

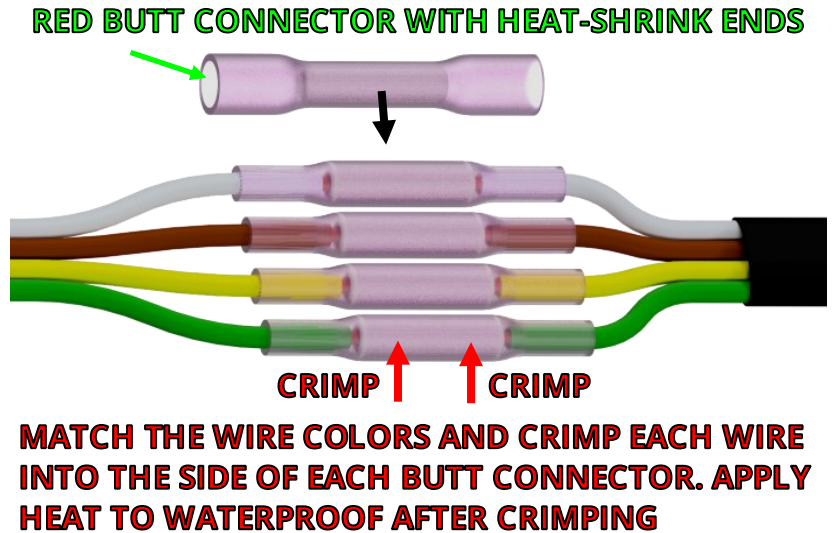

25. Secure harness to Stealth hitch frame with cable ties. Maintain an 18" loop from the cable tie to the 4-way plug. Add the magnetic cable holder and secure to the harness close to the 4-way plug, with a cable tie.

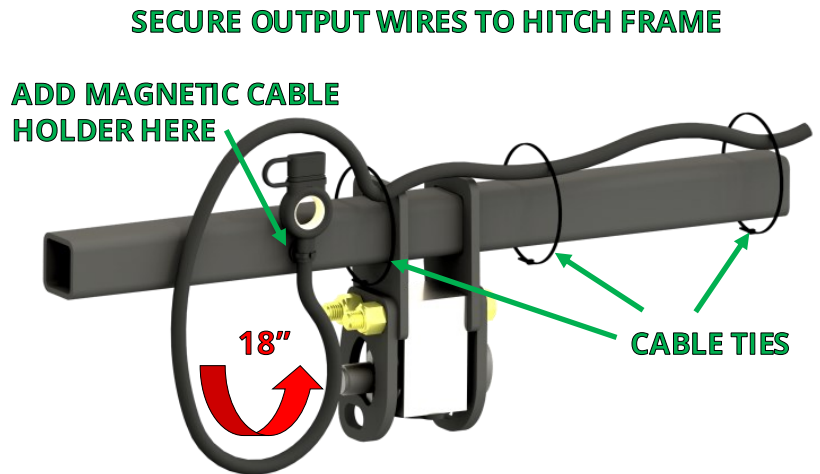

SIDE  
CUTTERS

26. Use adhesive foam strips to mount the control module to the rear wall of the cargo compartment. Use the (2) provided cable ties and cable tie mounts to secure the excess wiring.

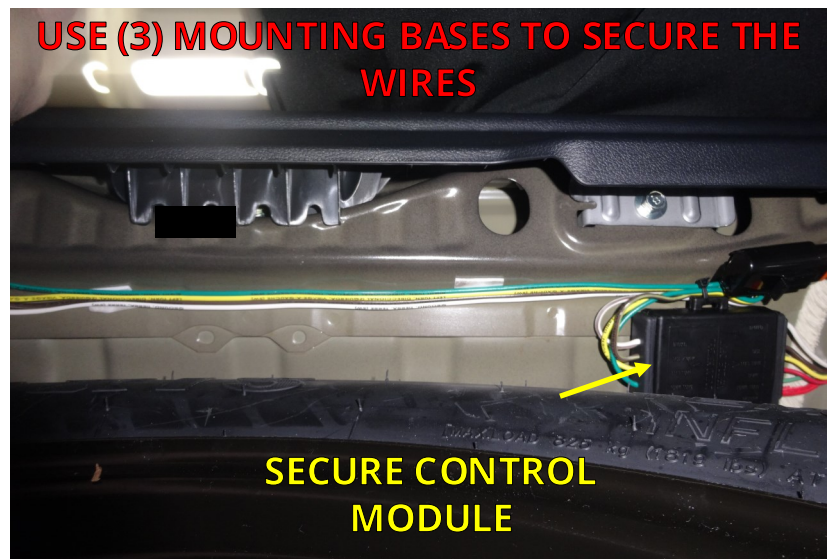



## INSTALL WIRING KIT CONTINUED



MULTIMETER

27. Test the 4-way plug using a multimeter or connect the plug to a trailer and verify that the lights and brakes work correctly.

**Note:** Taillights will need to be temporarily plugged in during testing.



SILICONE

28. Use silicone to waterproof the grommet.

## CUT ACCESS TO LATCH BLOCK



DREMEL TOOL

29. Cut the fascia with a Dremel tool. Use a file to smooth out the cut.



FILE

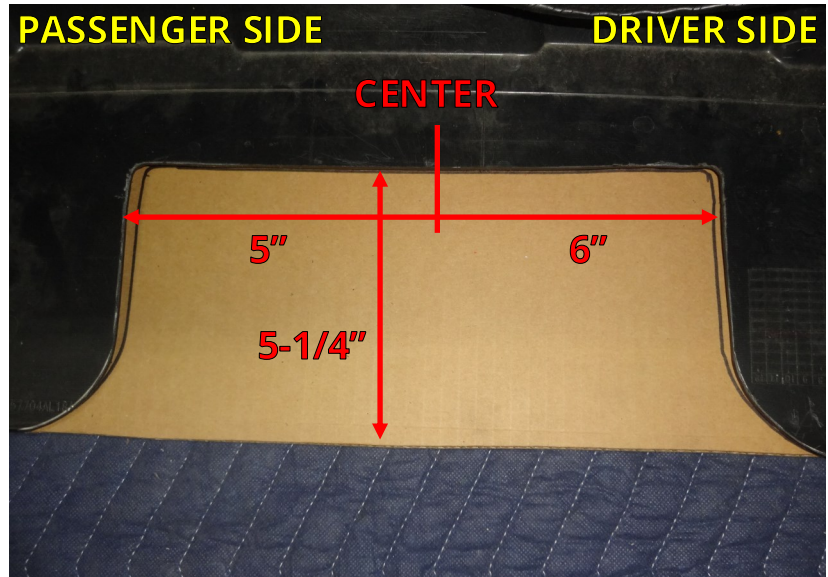

## REINSTALL VEHICLE COMPONENTS

30. Reattach and secure the fascia, taillights, and other vehicle components in reverse order. Refer to Steps 1-7 and 15-20.

**NOTICE:** Remember to plug in the sensor plug in Step 7 before reinstalling the fascia.





## FINAL VEHICLE EXAMINATION

31. Examine the body panels to ensure that they are in a pre-installation condition. Test the electronic functions of the vehicle. Correct any inconsistencies.
32. Ensure that hitch components work properly.
  - **Verify that the lock works correctly.** Push in the safety lock on the latch block then unlock with key. The lock should slide back out with the key when unlocked.
  - **Verify that each accessory can be installed correctly.** Use the following steps to install and remove each accessory that will be used with the hitch. (*Rack Receiver* and *Ball Mount* if purchased.)
    1. Prepare latching mechanism. Turn handle clockwise if needed.
    2. Firmly insert "post" of accessory into latch block until handle releases indicating that the accessory is latched.
    3. Push in the safety locking pin until it fully engages. The locking pin prevents the handle from turning when pushed in, and confirms that the block is securely latched onto the accessory. The safety locking pin will not depress if the accessory is not fully latched.
    4. Use key to release safety locking pin.
    5. While holding on to the accessory, rotate handle clockwise to release and remove the accessory.
  - **Verify that no part of the accessories come into contact with the body of the vehicle.**

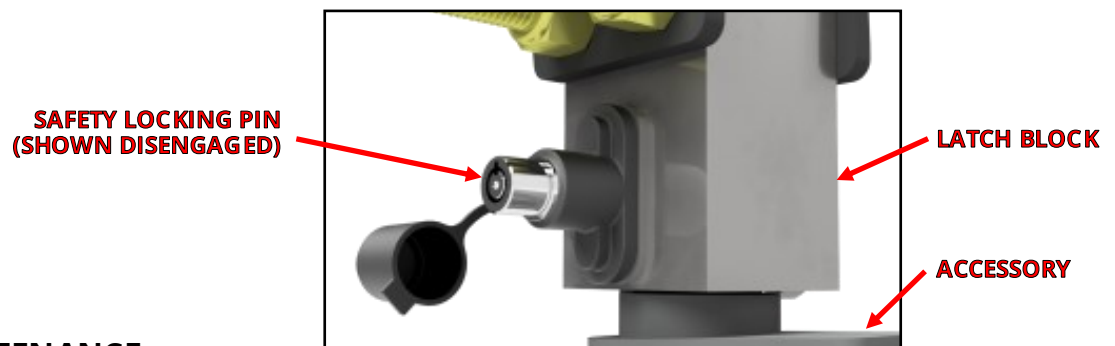

## PRODUCT USE AND MAINTENANCE

**NOTICE: If the hitch is being installed by a professional, the installer is responsible for training the end user in the use and maintenance of the product.**

- **Accessory installation procedure:**
  1. Prepare latching mechanism. Turn handle clockwise if needed.
  2. Firmly insert "post" of accessory into latch block until handle spins counter-clockwise indicating that the accessory is latched.
  3. Always depress the safety locking pin and check that it has fully engaged.
- **Never use any accessory with the safety lock disengaged.** Until the safety locking pin is engaged, the handle is able to turn. A fully engaged safety locking pin is confirmation that the accessory is properly latched into the latch block.
- **Never use the rack receiver for towing.** The rack receiver accessory is only to be used with payload carrying products, such as bike racks or luggage racks.
- **Before each use, give the post of the accessory a light coating of lithium based grease.**
- **Before each use, inspect the hitch to ensure that all bolted connections are secure and that no cracks or damage are present.** Do not tow with the hitch if cracks or damage outside of normal wear is found.
- **Remove the Stealth accessories from the latch block after each use.** Do not leave accessories plugged in for extended periods of time.