



HITCH INSTALLATION INSTRUCTIONS

MAKE: SUBARU YEARS: 2018 - 2021 MODEL/TRIM: CROSSTREK

www.stealthhitches.com 833•694•4824

RACK RECEIVER KIT#: **SHR66001**

COMPATIBLE WITH TOW KIT: **SHT25029**

2" RACK RECEIVER MAXIMUM PAYLOAD: 350 LBS
MAXIMUM TOW RATING: 3500 LBS
MAXIMUM TONGUE WEIGHT: 350 LBS

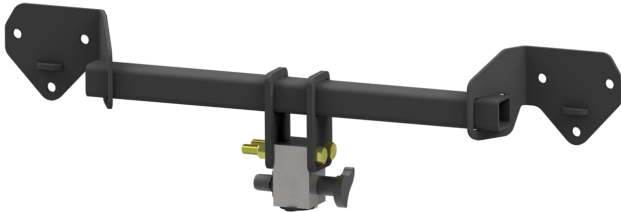

UNDER VEHICLE TRIMMING:

HEAT SHIELD: **NO**
FASCIA: **NO**
GRAVEL GUARD TRIMMING: **NO**



READ ALL INSTRUCTION WARNINGS AND LABELS



NO WELDING, METAL DRILLING OR VISIBLE TRIMMING REQUIRED

PARTS SUPPLIED WITH RACK RECEIVER KIT:



LATCH BLOCK



(2) BOLTS
5/8" - 11 x 5"



(2) 5/8"
NYLOCK NUTS



2" RACK RECEIVER



(2) BOLTS
7/16" x 1-1/2"



(2) 7/16" LOCK WASHERS



(2) 7/16" FLAT WASHERS

TOOLS REQUIRED:



15/16" OPEN END WRENCH



10mm, 14mm,
5/8" & 15/16"
SOCKETS

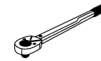

TORQUE WRENCH

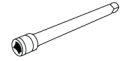

SOCKET EXTENSION



SAFETY GLASSES



RATCHET



FLASHLIGHT



PHILLIPS HEAD SCREWDRIVER



PLASTIC PRY TOOLS



90 DEGREE PICK

ADDITIONAL PARTS FOR TOW KIT:



BALL MOUNT
5" RISE, SHORT



CHAIN HOOKS



2" BALL

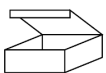

PASSIVE WIRING
KIT BOX

ADDITIONAL TOOLS FOR TOW KIT:



MULTIMETER



STRIPPER/
CRIMPING
TOOL



SILICONE



DRILL &
3/8" BIT

<THESE INSTRUCTIONS MUST BE GIVEN TO THE END USER>

NOTICE: Installation of Stealth products may or may not require the addition of a wiring harness to the vehicle.

- The Rack Receiver only product does not require adding a wiring harness.
- The Rack Receiver plus Tow Kit requires the addition of a "Passive" wiring harness to the vehicle. The passive harness "reads" the output of the vehicle's lights and translates the signals to the trailer without being connected to the vehicle computer.

INSTALLATION NOTE: In most instances, these instructions will only outline disassembly of vehicle components. Re-installation of components will require the installer to retain vehicle hardware and work through disassembly instructions in reverse order. When installation is complete, double check that all vehicle components have been replaced and are secured.

IMPORTANT SAFETY NOTICE FOR STEALTH HITCH INSTALLERS AND CUSTOMERS.

Read all installation and operating instructions along with all labels before installing or using this product. Do not perform any installation or towing procedures without fully understanding the correct tools and actions for all steps. Call for support if needed.

⚠ WARNING Failure to comply with the safety information in these instructions could result in serious injury or death.

- ⚠ Do not modify this product in any manner. Doing so could alter its integrity and lead to a loss of attachment between the trailer and the tow vehicle.
- ⚠ Adding Stealth hitch components to the chassis of any vehicle can be hazardous. There is potential for unexpected combustion of fuel, electric shock, burns, shifting or falling of unstable vehicle, damage to vehicle, injury from tool usage and many other hazards. This installation must be completed by someone who is aware of the hazards involved. This person must be knowledgeable of proper safety procedures for a vehicle modification of this nature, and for usage of the equipment required to perform the installation.
- ⚠ Without proper knowledge, towing can be a dangerous activity. Understand all the risks involved with towing before proceeding. For information on towing safety, see "**The Trailer Handbook: A Guide to Understanding Trailer and Towing Safety**" from the National Association of Trailer Manufacturers, www.NATM.com and your trailer and tow vehicle manufacturer's owner's manual.
- ⚠ Do not exceed tow or tongue rating of coupler, tow or tongue rating of hitch, or tow or weight ratings of tow vehicle or trailer. See vehicle and trailer manufacturer information for ratings. Exceeding these ratings may cause damage to towing components or loss of attachment between the trailer and vehicle.
- ⚠ While installation is being performed, check for signs of damage or excessive corrosion. Do not install hitch components over vehicle parts that are broken or have compromised structural integrity.
- ⚠ This product was designed to fit vehicles in their original, "as manufactured" condition. Compatibility with vehicles having replacement parts, or other modifications is not guaranteed. Inspect vehicle for modifications before installation of this product.
- ⚠ Some accessories, like the rack receiver, are not rated for towing. Do not use any accessories without proper knowledge of their use.
- ⚠ A visual inspection of the hitch should be performed before each use. Regularly check that all connections are secure, including those that secure the hitch to the vehicle. Check for cracks or damage to the hitch. Do not use the hitch if cracks or damage outside of normal wear is found. Using a hitch that has unsecure connections and/or cracks or damage could result in damage to the tow vehicle, trailer, towing components and loss of attachment between the tow vehicle and trailer.
- ⚠ Stealth hitches are not compatible with any weight distribution or sway control products. Adding additional products to the trailer or chassis which modifies the function of the Stealth hitch may cause hitch failure.

NOTICE: Installation of hitch requires removal of vehicle parts and interaction with vehicular electronics. Before installation, check the condition of body panels and note any locations where panels are not flush. Check the electronic functions of the vehicle, such as: headlights, taillights, turn signals, cameras, backup sensors, Parking Distance Controller (PDC), foot activated cargo access, etc. It is the responsibility of the installer to restore the fit and function of the vehicle

GAIN ACCESS TO MOUNTING AREA



1. Open the rear door of the vehicle. Locate the plastic cover next to the rear taillights. Remove (2) screw caps then remove (2) screws. Repeat on the other side of the vehicle.



2. Remove the rear taillights by sliding rearward. Unplug light plugs from the rear taillights.

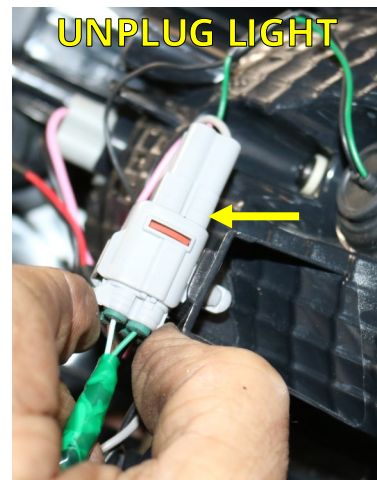

3. Inside the rear wheel well, behind the tire, locate (1) push in rivet (yellow arrow) and (2) screws (green arrows). Remove the rivet and screws. Remove (1) plastic rivet below the vehicle (red arrow). Remove the mud flap.



GAIN ACCESS TO MOUNTING AREA CONTINUED



90 DEGREE PICK

4. Underneath the vehicle, remove (3) rivets from the bottom edge of the fascia. Repeat Steps 3-4 on other side of vehicle.



PLASTIC PRY TOOLS

5. The rear fascia is clipped to the vehicle body above and behind the wheel wells. Pull outward on the top from of the rear fascia to release clips. Continue applying outward and rearward pressure until all clips are released.
6. This step requires a partner. Slide the fascia rearward, keep the fascia close to the vehicle. Unplug sensor plug on driver side, before removing the fascia completely.



NOTICE: Carefully remove the fascia and place on a blanket or pad.



14mm SOCKET

7. Use a socket to remove (4) bolts and (2) nuts that secure the factory reinforcement beam.

SAVE the factory reinforcement beam, bolts, and nuts for reinstallation.

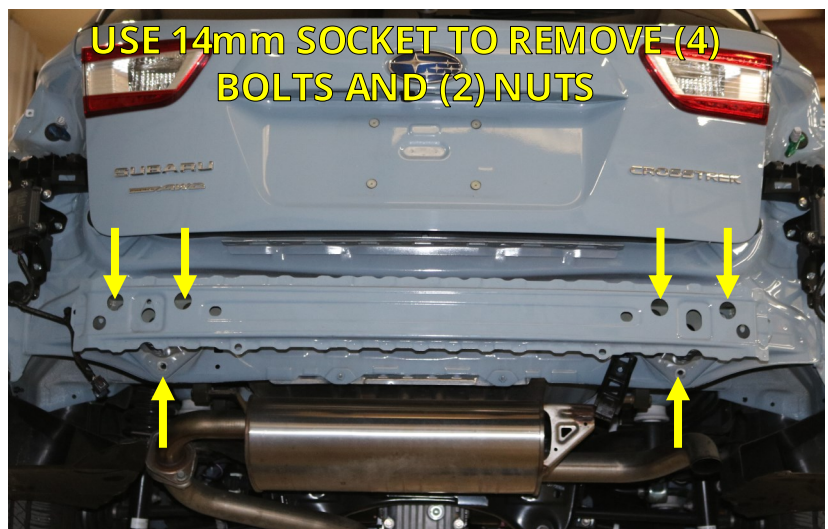

INSTALL STEALTH HITCH FRAME

- Remove the first rubber grommet on the bottom of the chassis channels. Align the Stealth hitch frame with the vehicle studs and holes. Slide the hitch tabs into the exposed chassis channels and align the hitch holes with vehicle studs. On the bottom of each chassis channel, insert a supplied 7/16" bolt, lock washer, and flat washer. Hand tighten bolts.

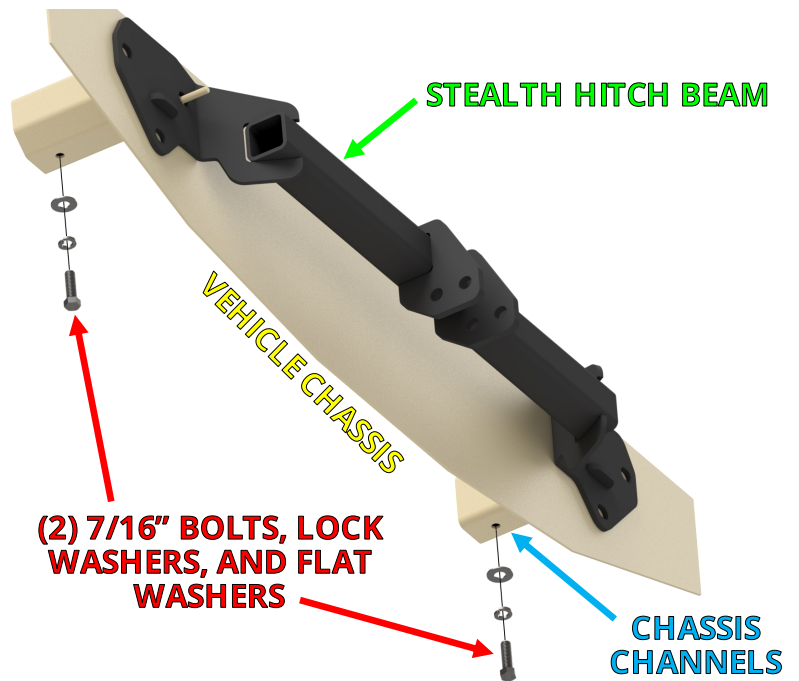

14mm
SOCKET



5/8"
SOCKET



TORQUE
WRENCH

- Install the factory reinforcement beam on top of the Stealth hitch frame and center. Use the saved factory (2) nuts and (4) bolts to fasten the hitch. Torque the factory nuts and bolts to 45 ft.-lbs. Torque the (2) 7/16" bolts under the chassis channels to 65 ft.-lbs.

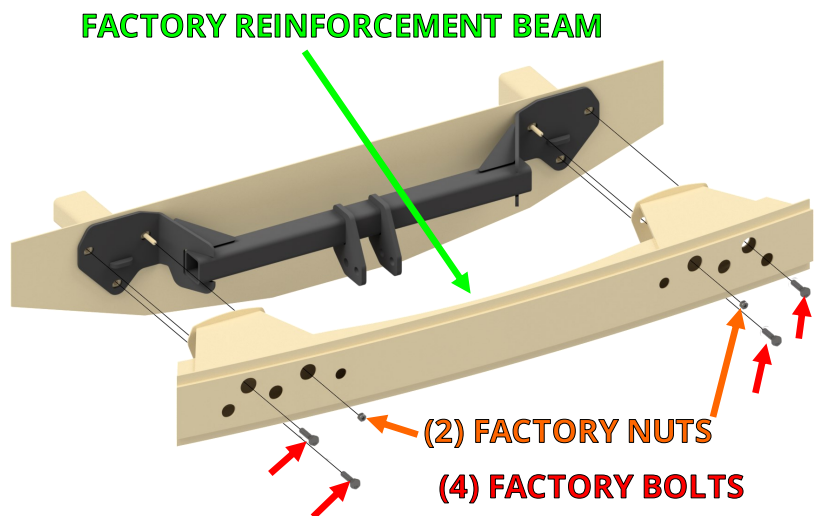

MOUNT LATCH BLOCK



15/16"
SOCKET



15/16" OPEN
END WRENCH



TORQUE
WRENCH

10. Installation of the latch block varies depending on which kit you are installing.

- **Rack Receiver Kit:** Install the latch block with (2) 5/8"-11 x 5" bolts and (2) 5/8" nylock nuts. Tighten each bolt to 150 ft.-lbs.
- **Tow Kit:** Install the latch block and (2) chain hooks with (2) 5/8"-11 x 5" bolts and (2) 5/8" nylock nuts. Tighten each bolt to 150 ft.-lbs.

NOTICE: Keys are packaged within the latch block, remove keys and store in safe location.

RACK RECEIVER KIT INSTALL



TOW KIT INSTALL

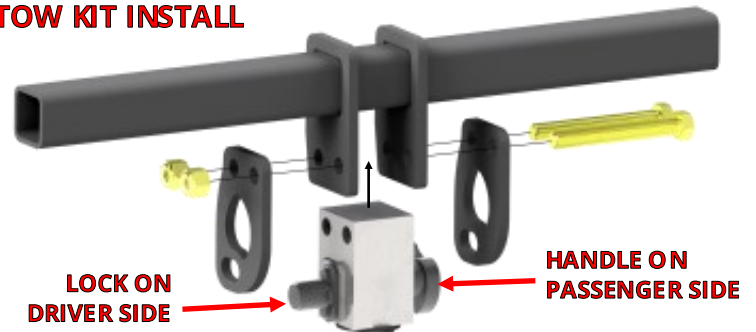

IF INSTALLING A RACK RECEIVER KIT, SKIP TO STEP 23.
IF INSTALLING A TOW KIT, CONTINUE TO STEP 11.

INSTALL PASSIVE WIRING KIT

| # | DESCRIPTION | QTY |
|---|--|-----|
| 1 | SUBARU 4-WAY HARNESS KIT <ul style="list-style-type: none"> CONTROL MODULE 4-WAY PLUG & WIRE CABLE TIE - 6" | 1 |
| 2 | ADHESIVE FOAM STRIP | 2 |
| 3 | CABLE TIE MOUNTS | 3 |
| 4 | MAGNETIC CABLE HOLDER | 1 |
| 5 | 4-WAY FLAT CONNECTOR COVER | 1 |
| 6 | CABLE TIE - 14" | 2 |



11. Locate the wiring kit box. Review the contents of the box against the list above to check for missing components. The passive wiring kit uses a control module to manage the functions of the trailer lighting. The module has an **"input"** side that receives power from the vehicle's wiring harness. The **"output"** side of the module delivers this information to the 4-way plug. The control module is connected to the vehicle's wiring harness as outlined in the next steps.

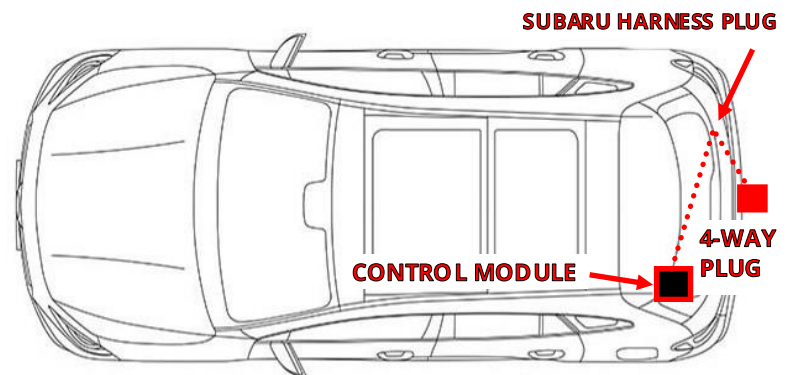
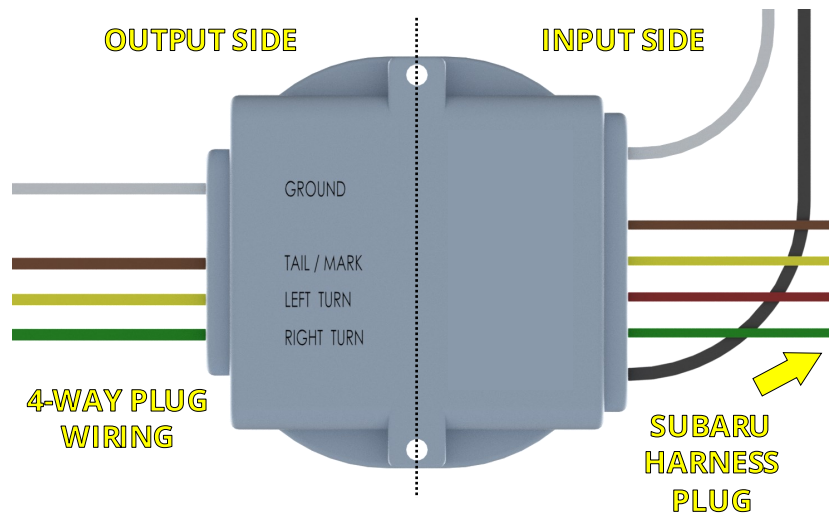

INSTALL WIRING KIT CONTINUED



90 DEGREE PICK

12. Remove the cargo floor panel by lifting it up and out. Place panel on blanket or safe area.
13. Remove the foam holder by removing (4) plastic rivets. Place holder on blanket or safe area.

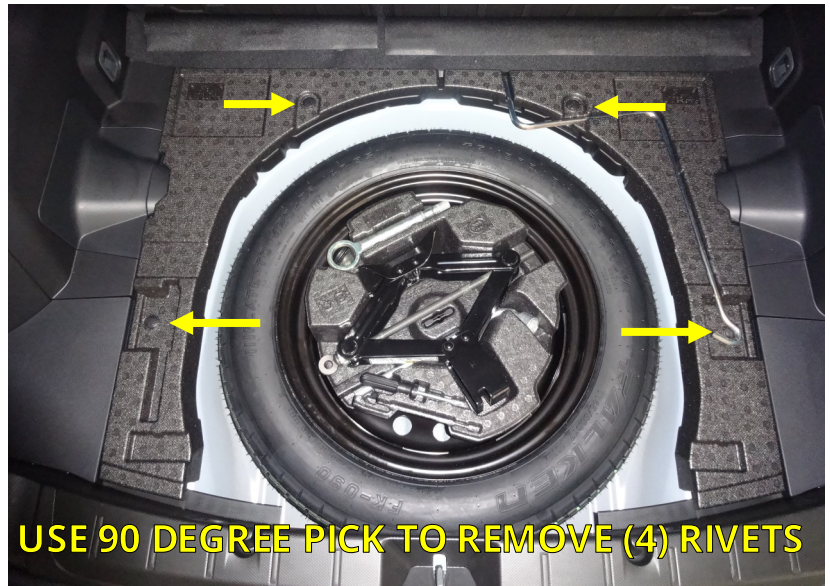

90 DEGREE PICK



PLASTIC PRY TOOLS

14. In the rear wall of the vehicle cargo area use a 90 degree pick to remove (2) plastic rivets. Remove the threshold by using a plastic pry tool to pry upward then lifting up.

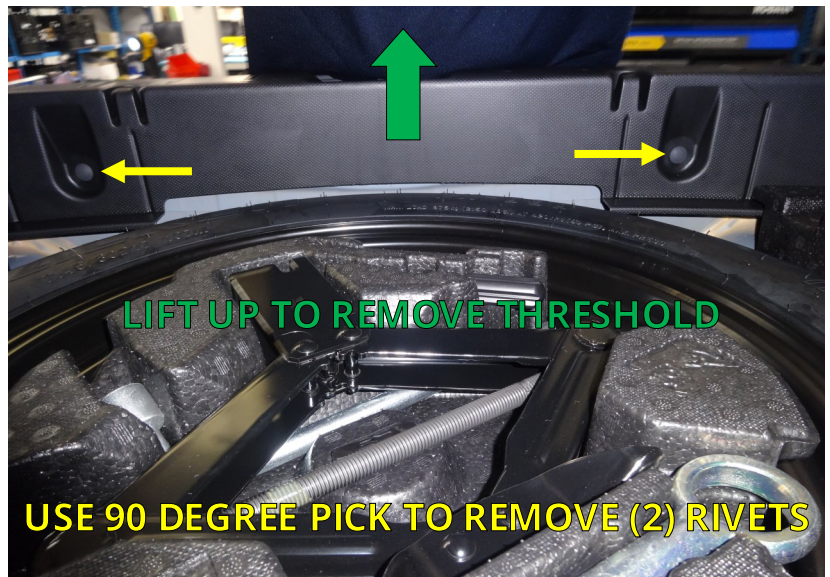

15. Locate the factory trailer harness plug on the driver side of the rear cargo area wall. Retrieve the Subaru control module and plug the input side plug into the trailer harness plug.
16. Use adhesive foam strips to mount the control module to the rear wall of the cargo compartment behind the plastic trim piece.

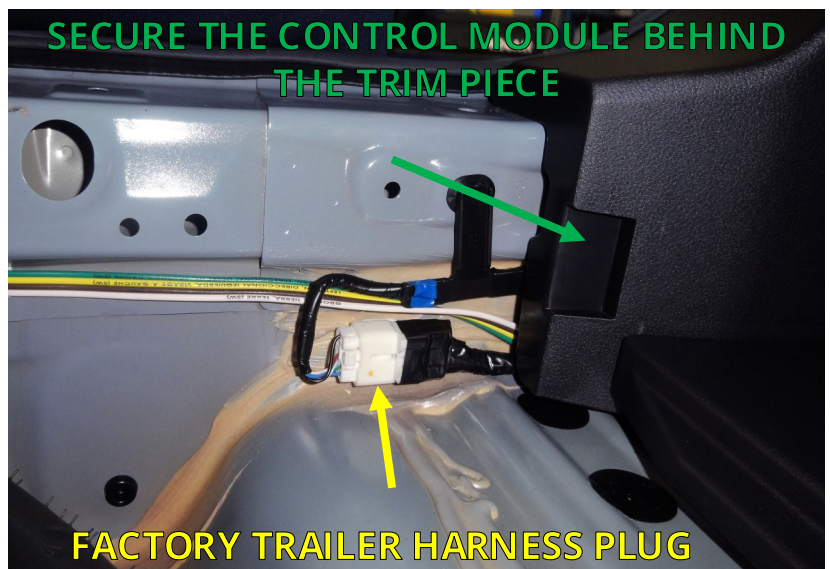

INSTALL WIRING KIT CONTINUED



DRILL &
3/8" BIT

17. Locate and remove the rubber grommet from the passenger side of rear wall. Drill a 3/8" hole in grommet. Retrieve the 4-way plug with wire. Pass the grommet over the wires so the plug will be on the outside of the vehicle. Thread the ends of the wires into the hole and replace the grommet.

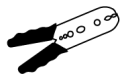
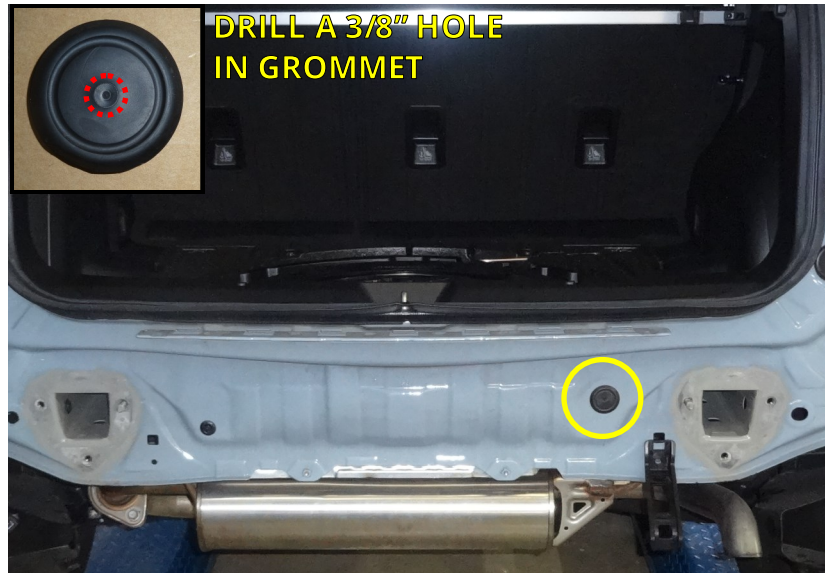

STRIPPER/
CRIMPING
TOOL

18. Match the colors and use a crimping tool to crimp the output wires to the harness inside the vehicle. Secure the output wires.

NOTICE (OPTIONAL): The butt splice connectors are heat shrink connectors. Apply heat to waterproof the connectors after crimping.

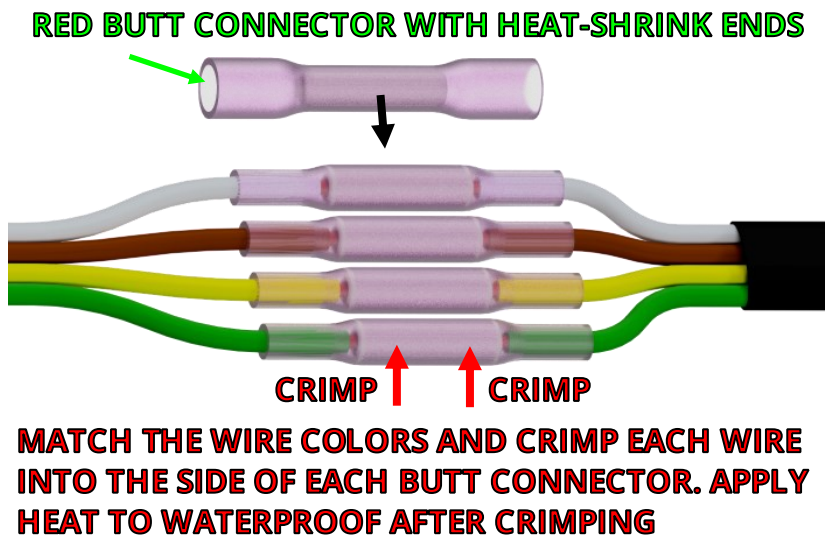

19. Secure harness to Stealth hitch frame with cable ties. Maintain an 18" loop from the cable tie to the 4-way plug. Add the magnetic cable holder and secure to the harness close to the 4-way plug, with a cable tie.

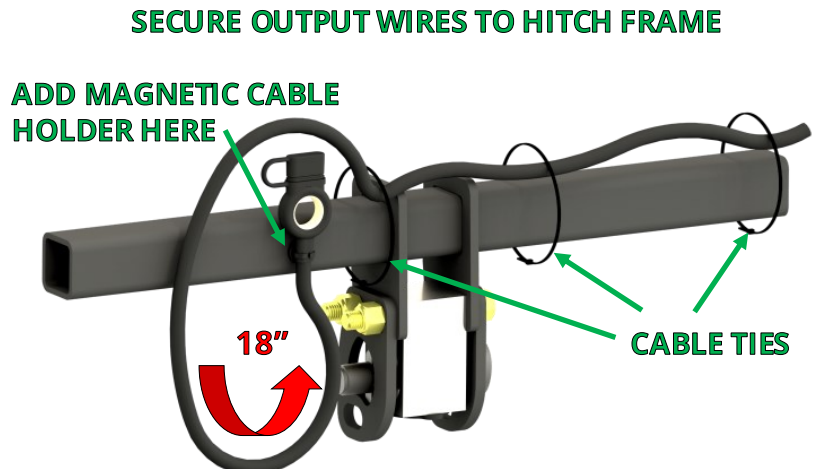

INSTALL WIRING KIT CONTINUED



MULTIMETER



SILICONE

20. Use the (3) provided cable ties and cable tie mounts to secure the excess wiring.

21. Test the 4-way plug using a multimeter or connect the plug to a trailer and verify that the lights and brakes work correctly.

Note: *Taillights will need to be temporarily plugged in during testing.*

22. Use silicone to waterproof the grommet.

REINSTALL VEHICLE COMPONENTS

23. Reattach and secure the fascia, taillights, and other vehicle components in reverse order. Refer to Steps 1-6 and 12-14.

NOTICE: *Remember to reconnect the electrical sensor plug (Step 6) before reinstalling the fascia.*



FINAL VEHICLE EXAMINATION

24. Examine the body panels to ensure that they are in a pre-installation condition. Test the electronic functions of the vehicle. Correct any inconsistencies.
25. Ensure that hitch components work properly.
 - **Verify that the lock works correctly.** Push in the safety lock on the latch block then unlock with key. The lock should slide back out with the key when unlocked.
 - **Verify that each accessory can be installed correctly.** Use the following steps to install and remove each accessory that will be used with the hitch. (*Rack Receiver* and *Ball Mount* if purchased.)
 1. Prepare latching mechanism. Turn handle clockwise if needed.
 2. Firmly insert "post" of accessory into latch block until handle releases indicating that the accessory is latched.
 3. Push in the safety locking pin until it fully engages. The locking pin prevents the handle from turning when pushed in, and confirms that the block is securely latched onto the accessory. The safety locking pin will not depress if the accessory is not fully latched.
 4. Use key to release safety locking pin.
 5. While holding on to the accessory, rotate handle clockwise to release and remove the accessory.
 - **Verify that no part of the accessories come into contact with the body of the vehicle.**

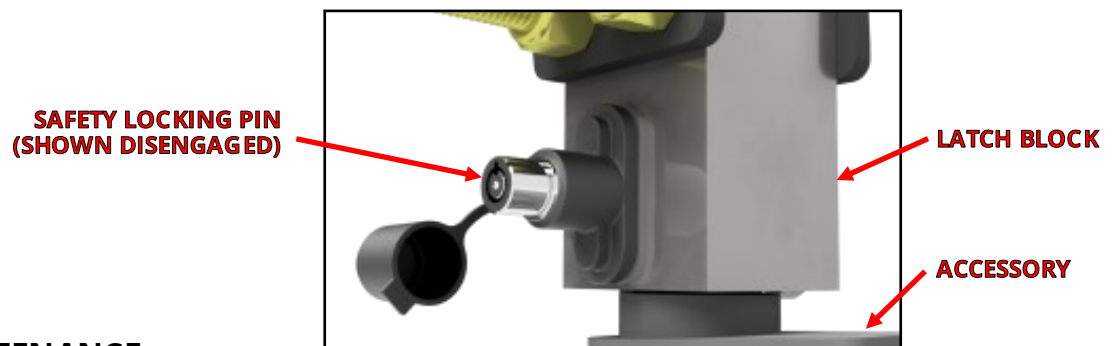

PRODUCT USE AND MAINTENANCE

NOTICE: If the hitch is being installed by a professional, the installer is responsible for training the end user in the use and maintenance of the product.

- **Accessory installation procedure:**
 1. Prepare latching mechanism. Turn handle clockwise if needed.
 2. Firmly insert "post" of accessory into latch block until handle spins counter-clockwise indicating that the accessory is latched.
 3. Always depress the safety locking pin and check that it has fully engaged.
- **Never use any accessory with the safety lock disengaged.** Until the safety locking pin is engaged, the handle is able to turn. A fully engaged safety locking pin is confirmation that the accessory is properly latched into the latch block.
- **Never use the rack receiver for towing.** The rack receiver accessory is only to be used with payload carrying products, such as bike racks or luggage racks.
- **Before each use, give the post of the accessory a light coating of lithium based grease.**
- **Before each use, inspect the hitch to ensure that all bolted connections are secure and that no cracks or damage are present.** Do not tow with the hitch if cracks or damage outside of normal wear is found.
- **Remove the Stealth accessories from the latch block after each use.** Do not leave accessories plugged in for extended periods of time.