



www.stealthhitches.com 833-694-4824

# HITCH INSTALLATION INSTRUCTIONS

**MAKE:**  
KIA

**YEARS:**  
2022 - 2024  
2022 - 2024  
2022  
2023 - 2024

**MODEL/TRIM:**  
EV6 GT-line AWD/RWD  
EV6 Wind AWD/RWD  
EV6 Light RWD  
EV6 GT e-AWD

RACK RECEIVER KIT#: **SHR63002**

COMPATIBLE WITH TOW KITS: **SHT25050, SHT25050A & SHT25059**

**2" RACK RECEIVER MAXIMUM PAYLOAD:** 350 LBS

**MAXIMUM TOW RATING:** 3500 LBS

**MAXIMUM TONGUE WEIGHT:** 350 LBS

**AUSTRALIA AND NEW ZEALAND ONLY:**

**2" RACK RECEIVER MAX. PAYLOAD:** 100 KG (221 LBM)

**MAX. TOW RATING:** 1,000 KG (2,205 LBM) AS4177.1 - 2004

**MAX. TONGUE WEIGHT:** 100 KG (221 LBM)

## UNDER VEHICLE TRIMMING:

HEAT SHIELD: **NO** FASCIA: **NO**  **READ ALL INSTRUCTION GRVEL GUARD TRIMMING: YES** **WARNINGS AND LABELS**

 **NO WELDING, METAL DRILLING OR VISIBLE TRIMMING REQUIRED**

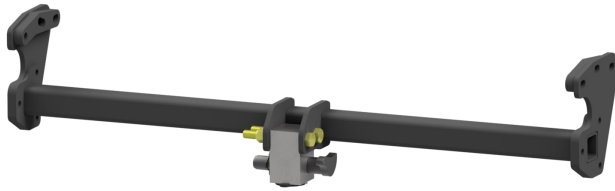

## PARTS SUPPLIED WITH RACK RECEIVER KIT:

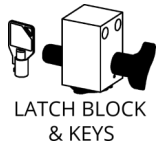

LATCH BLOCK & KEYS



(2) BOLTS  
5/8"-11 x 5"



(2) 5/8"  
NYLOCK NUTS



2" RACK  
RECEIVER



(2) SIDE PLATES

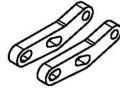

(2) SPACERS

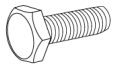

(6) M12 1.25 x  
50mm BOLTS

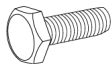

(8) 1/2" - 13 x  
1-1/2" BOLTS



(6) 1/2" FLAT  
WASHERS



(14) 1/2" LOCK  
WASHERS



(8) 1/2" NUTS

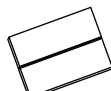

(1) ADHESIVE  
FOAM STRIP



(2) 14" CABLE  
TIES

## ADDITIONAL PARTS FOR TOW KIT:

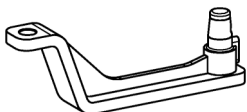

BALL MOUNT  
7" RISE, EXTRA LONG



CHAIN HOOKS



2" BALL  
(SHT25050)  
(SHT25050A)

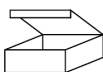

PASSIVE OR **ACTIVE**  
WIRING HARNESS KIT  
BOX



50mm BALL  
(SHT25059 only)

## TOOLS REQUIRED:



15/16" OPEN  
END WRENCH



10mm, 14mm,  
19mm, & 15/16"  
SOCKETS



TORQUE  
WRENCH

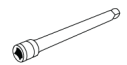

SOCKET  
EXTENSION



RATCHET



SAFETY GLASSES



FLASHLIGHT



FILE



DREMEL TOOL



90 DEGREE  
PICK



PLASTIC  
PRY TOOLS

## ADDITIONAL TOOLS FOR **ACTIVE** & **PASSIVE** TOW KITS:



MULTIMETER

## ADDITIONAL TOOLS FOR **PASSIVE** TOW KITS:



PLIERS



STRIPPER/  
CRIMPING  
TOOL



DRILL &  
3/8" BIT



FLATHEAD  
SCREWDRIVER



SILICONE



**Australia and New Zealand customers installing a Tow Kit see special instructions on bottom of Page 5.**

**RACK RECEIVER KIT INSTALLATION:** USE STEPS 1-7 & 36-39

**PASSIVE TOW KIT INSTALLATION:** USE STEPS 1-26 & 36-39

**ACTIVE TOW KIT INSTALLATION:** USE STEPS 1-8, & 27-39

# <THESE INSTRUCTIONS MUST BE GIVEN TO THE END USER>

NOTICE: Installation of Stealth products may or may not require the addition of a wiring harness to the vehicle.

- The Rack Receiver only product does not require adding a wiring harness.
- The Rack Receiver plus Tow Kit requires the addition a wiring harness that is compatible with the vehicle's wiring. Depending on the vehicle, the harness will be one of two types, "Active" or "Passive." The wiring section of the instructions will indicate which wiring harness style is being used and how to install it.
- The **Active Harness** plugs into the vehicle's wiring so that the vehicle's computer can communicate with the trailer wiring. This allows certain functions such as cameras or backup alarms to continue to operate as designed.
- The **Passive Harness** is independent of the vehicle's computer and communication system. The module of the harness is powered directly from the battery rather than the vehicle's wiring harness. The module monitors the output signals from the vehicle's lights. It then powers and activates the trailer lighting accordingly.









**INSTALLATION NOTE:** In most instances, these instructions will only outline disassembly of vehicle components. Re-installation of components will require the installer to retain vehicle hardware and work through disassembly instructions in reverse order. When installation is complete, double check that all vehicle components have been replaced and are secured.

## IMPORTANT SAFETY NOTICE FOR STEALTH HITCH INSTALLERS AND CUSTOMERS.

Read all installation and operating instructions along with all labels before installing or using this product. Do not perform any installation or towing procedures without fully understanding the correct tools and actions for all steps. Call for support if needed.

### **WARNING**

**Failure to comply with the safety information in these instructions could result in serious injury or death.**

-  Do not modify this product in any manner. Doing so could alter its integrity and lead to a loss of attachment between the trailer and the tow vehicle.
-  Adding Stealth hitch components to the chassis of any vehicle can be hazardous. There is potential for unexpected combustion of fuel, electric shock, burns, shifting or falling of unstable vehicle, damage to vehicle, injury from tool usage and many other hazards. This installation must be completed by someone who is aware of the hazards involved. This person must be knowledgeable of proper safety procedures for a vehicle modification of this nature, and for usage of the equipment required to perform the installation.
-  Without proper knowledge, towing can be a dangerous activity. Understand all the risks involved with towing before proceeding. For information on towing safety, see "**The Trailer Handbook: A Guide to Understanding Trailer and Towing Safety**" from the National Association of Trailer Manufacturers, [www.NATM.com](http://www.NATM.com) and your trailer and tow vehicle manufacturer's owner's manual.
-  Do not exceed tow or tongue rating of coupler, tow or tongue rating of hitch, or tow or weight ratings of tow vehicle or trailer. See vehicle and trailer manufacturer information for ratings. Exceeding these ratings may cause damage to towing components or loss of attachment between the trailer and vehicle.
-  While installation is being performed, check for signs of damage or excessive corrosion. Do not install hitch components over vehicle parts that are broken or have compromised structural integrity.
-  This product was designed to fit vehicles in their original, "as manufactured" condition. Compatibility with vehicles having replacement parts, or other modifications is not guaranteed. Inspect vehicle for modifications before installation of this product.
-  Some accessories, like the rack receiver, are not rated for towing. Do not use any accessories without proper knowledge of their use.
-  A visual inspection of the hitch should be performed before each use. Regularly check that all connections are secure, including those that secure the hitch to the vehicle. Check for cracks or damage to the hitch. Do not use the hitch if cracks or damage outside of normal wear is found. Using a hitch that has unsecure connections and/or cracks or damage could result in damage to the tow vehicle, trailer, towing components and loss of attachment between the tow vehicle and trailer.
-  Stealth hitches are not compatible with any weight distribution or sway control products. Adding additional products to the trailer or chassis which modifies the function of the Stealth hitch may cause hitch failure.

**NOTICE:** Installation of hitch requires removal of vehicle parts and interaction with vehicular electronics. Before installation, check the condition of body panels and note any locations where panels are not flush. Check the electronic functions of the vehicle, such as: headlights, taillights, turn signals, cameras, backup sensors, Parking Distance Controller (PDC), foot activated cargo access, etc. It is the responsibility of the installer to restore the fit and function of the vehicle.

## GAIN ACCESS TO MOUNTING AREA



90 DEGREE PICK



14mm SOCKET



10mm SOCKET

1. Underneath the rear of the vehicle, use a 90 degree pick tool to remove (6) plastic rivets (yellow arrows). Use a 10mm socket to loosen (3) nuts (green arrows). Use a 14mm socket to loosen (1) nut (red arrow). Remove the gravel guard.

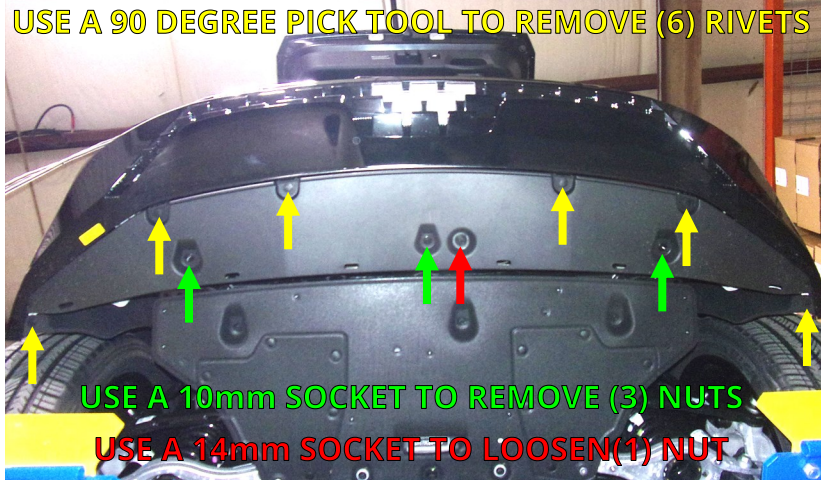

10mm SOCKET

2. With the gravel guard removed, locate the two support brackets shown in the image. Use a socket to remove and discard the brackets and nuts.



3. Retrieve (3) M12 bolts from the bolt bag. Locate the (3) holes on each side of the vehicle frame near the rear of the vehicle. Screw a bolt into each hole. This will help ensure that there are no obstructions in the hole. If the bolt will not easily thread into any hole, clean the threads with an M12-1.25 thread chaser.

**NOTICE:** There are 1/2" bolts included in the bolt bag. Do not thread the 1/2" bolts into the vehicle frame, doing so may damage the threads.

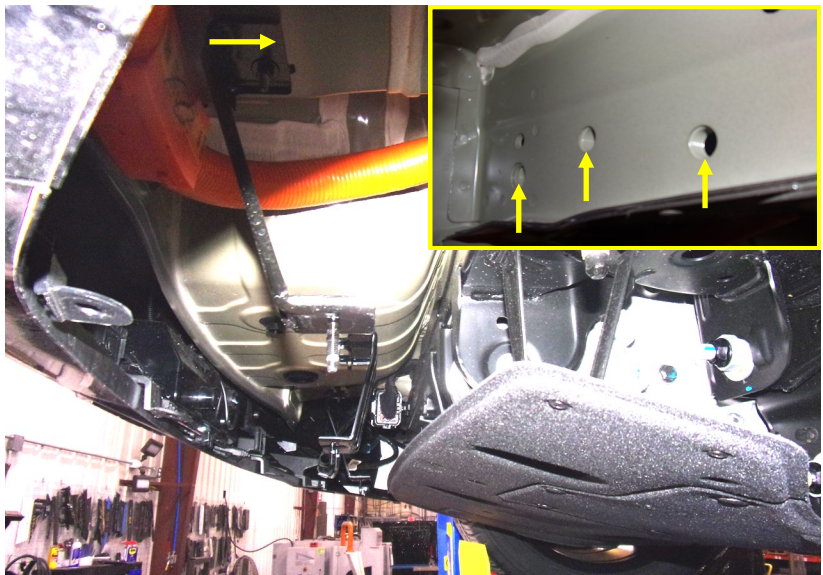

## INSTALL STEALTH HITCH



19mm  
SOCKET

- Using (3) M12 bolts, 1/2" lock washers and 1/2" flat washers loosely attach the side plate and spacer to the outside of the vehicle frame, as shown. Repeat on other side of vehicle.

**NOTICE:** Do not tighten hardware at this time.

**NOTE:** Use the provided double adhesive foam strip to attach the spacers to the side plates before installation to simplify procedure.

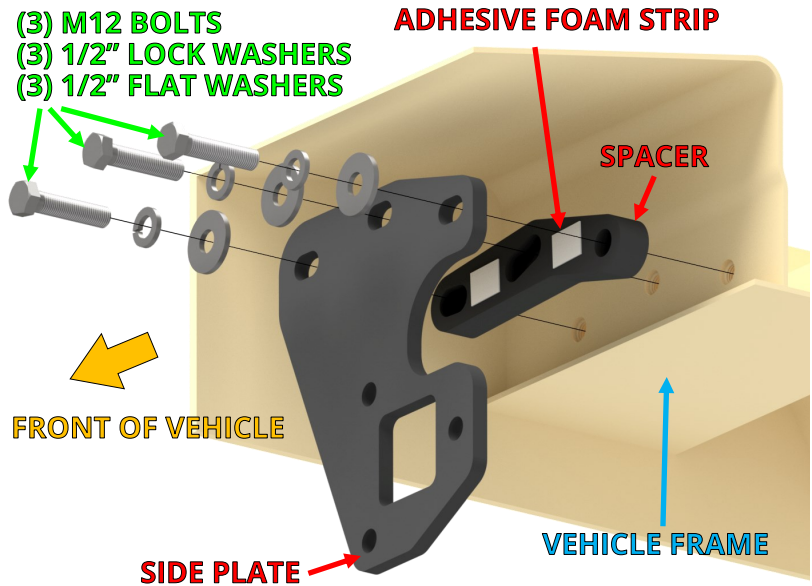

19mm  
SOCKET



TORQUE  
WRENCH

- Retrieve the Stealth hitch frame. Raise the frame between the side plates. The block brackets will need to be rotated up when being raised into the vehicle. Attach the frame to the side plates using (6) 1/2" bolts, 1/2" lock washers, and 1/2" nuts, as shown.

**NOTICE:** Before tightening the bolts securing the Stealth hitch frame to the vehicle, make sure to pull/slide the hitch frame all the way to the rear, away from the vehicle.

- Torque the M12 bolts to 85 ft.-lbs. Next, torque the 1/2" bolts and nuts to 100 ft.-lbs.

**NOTE:** There are (2) extra sets of 1/2" hardware in the bolt bag, which may be discarded.

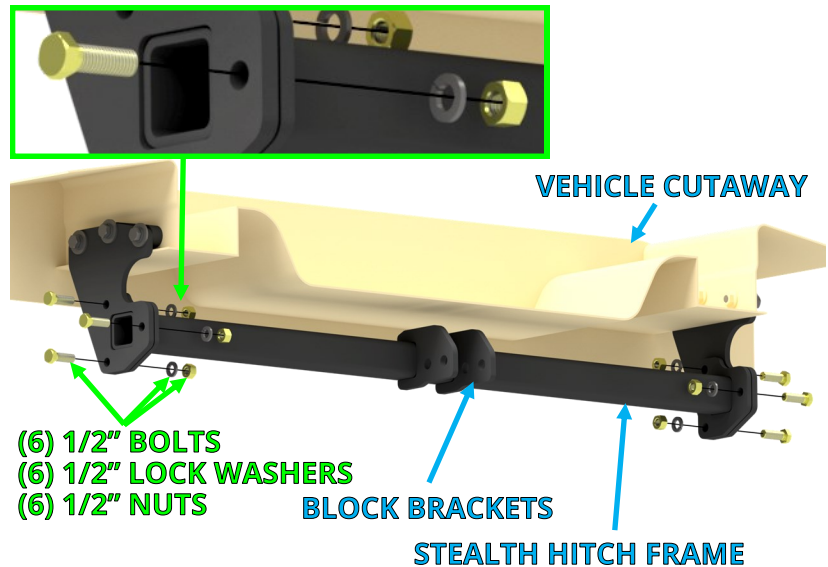

## MOUNT LATCH BLOCK



15/16"  
SOCKET



15/16" OPEN  
END WRENCH



TORQUE  
WRENCH

7. Installation of the latch block varies depending on which kit you are installing.

- **Rack Receiver Kit:** Install the latch block with (2) 5/8"-11 x 5" bolts and (2) 5/8" nylock nuts. Tighten each bolt to 150 ft.-lbs.
- **Tow Kit:** Install the latch block and (2) chain hooks with (2) 5/8"-11 x 5" bolts and (2) 5/8" nylock nuts. Tighten each bolt to 150 ft.-lbs.

**NOTICE:** Keys are packaged within the latch block, remove keys and store in safe location.



**IF INSTALLING A RACK RECEIVER KIT, SKIP TO STEP 36.  
IF INSTALLING A TOW KIT, CONTINUE TO STEP 8.**

### RACK RECEIVER KIT INSTALL

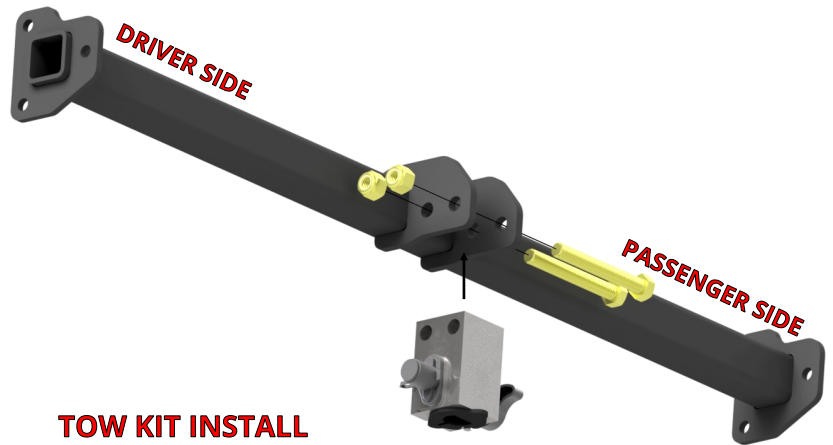

### TOW KIT INSTALL

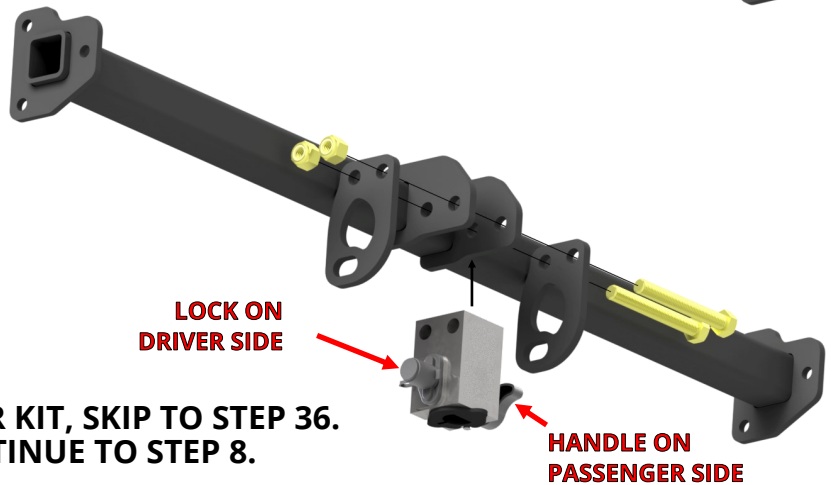

## SPECIAL NOTICE FOR Australia and New Zealand customers

- **NOTICE:** Tow kit SHT25059 is made specifically for the Australia and New Zealand market and contains a 50mm Ball. Stealth does not provide a wiring harness with this tow kit (skip Steps 8-35). Electrical plug connections must be sourced independently.

## INSTALL WIRING KIT

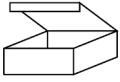

PASSIVE OR ACTIVE WIRING HARNESS KIT BOX

- Locate the wiring kit box. Review the contents of the box against the list below to check for missing components.
  - The passive wiring kit** uses a control module to manage the functions of the trailer lighting. The module has an “input” side that receives power from the vehicle’s battery and signals from the vehicle’s taillights. The “output” side of the module delivers this information to the 4-way plug, see *passive harness diagram*. The control module is connected to the vehicle’s battery and taillight wiring as outlined in the next steps.
  - The active wiring kit** uses a Kia computer control module to manage the functions of the trailer lighting. The module will connect to the vehicle through an included wire harness. The harness has an “input” side that receives power and signals from the vehicle’s electronic systems and delivers them to the control module. The “output” side of the harness delivers this information from the control module to the 4-way plug. The harness and control module installation are outlined in the next steps.

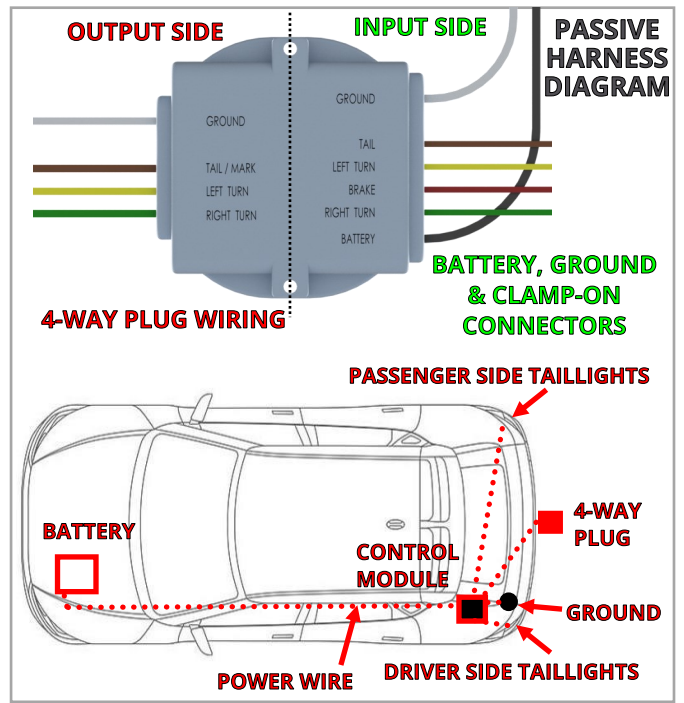

### PASSIVE WIRING KIT BOX

| #  | DESCRIPTION            | QTY |
|----|------------------------|-----|
| 1  | 4-WAY PLUG WITH WIRE   | 1   |
| 2  | CONTROL MODULE         | 1   |
| 3  | 4-WAY CONNECTOR COVER  | 1   |
| 4  | CABLE TIE - 8"         | 8   |
| 5  | CABLE TIE - 14"        | 2   |
| 6  | MAGNETIC CABLE HOLDER  | 1   |
| 7  | M8 SERRATED FLANGE NUT | 1   |
| 8  | FORK TERMINAL          | 1   |
| 9  | ADHESIVE FOAM STRIP    | 2   |
| 10 | BUTT CONNECTOR (BLUE)  | 1   |
| 11 | BUTT CONNECTOR (RED)   | 4   |
| 12 | CLAMP-ON CONNECTORS    | 4   |
| 13 | POWER WIRE             | 1   |



### ACTIVE WIRING KIT BOX



| # | DESCRIPTION           | QTY |
|---|-----------------------|-----|
| 1 | OUTPUT HARNESS        | 1   |
| 2 | INPUT HARNESS W/ FUSE | 1   |
| 3 | CONTROL MODULE        | 1   |
| 4 | CABLE TIE - 8"        | 9   |
| 5 | CABLE TIE - 14"       | 2   |
| 6 | ADHESIVE FOAM STRIP   | 1   |
| 7 | MAGNETIC CABLE HOLDER | 1   |

**NOTICE:** Do not allow electrical system to become disconnected from power or ground. Doing so may interrupt electrical systems.

## INSTALL WIRING KIT CONTINUED



IF INSTALLING A PASSIVE TOW KIT, CONTINUE TO STEP 9.  
IF INSTALLING AN ACTIVE TOW KIT, SKIP TO STEP 27.

## INSTALL PASSIVE WIRING KIT

9. Inside the rear cargo area, lift up the floor panel and remove.



10. On the floor of the cargo area, use a plastic pry tool to release (2) clips. Lift up and remove the plastic floor panel.

**NOTE:** The clips may be on either side of the floor panel



-or-



11. Use a pry tool or flat head screwdriver to turn the (2) plastic rivets 90 degrees. Remove the plastic rivets securing the rear threshold, as shown. Lift up on the threshold and remove.

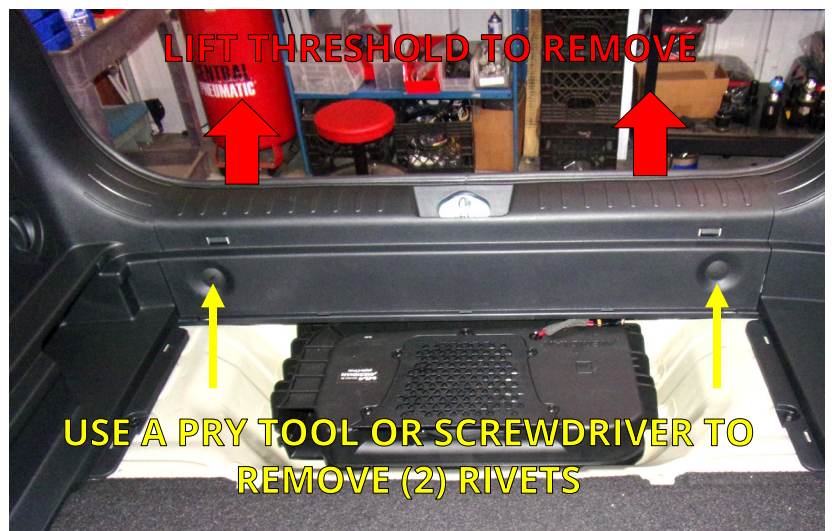

## INSTALL PASSIVE WIRING KIT CONTINUED



12. On either side of the cargo area, use a plastic pry tool to remove the two panels, as shown.

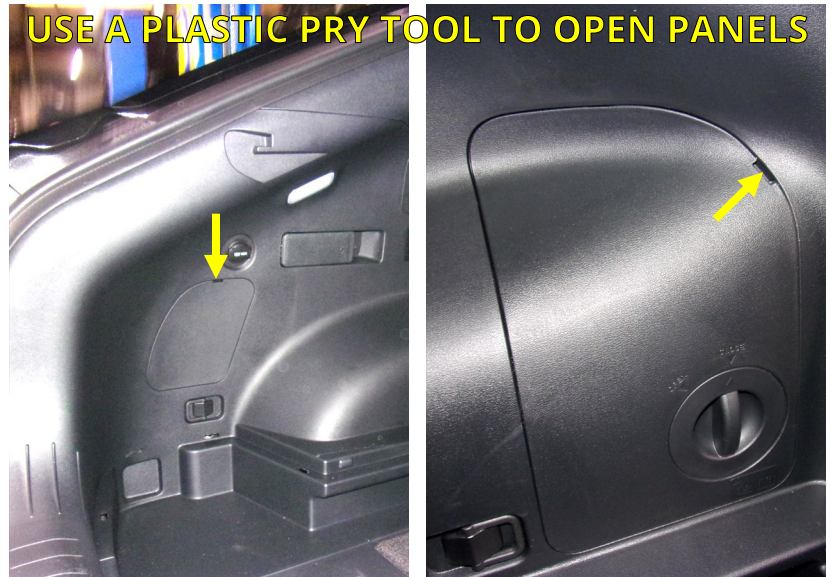

13. Retrieve the control module from the wiring kit box. place the control module inside the open panel behind the driver side cargo area wall.

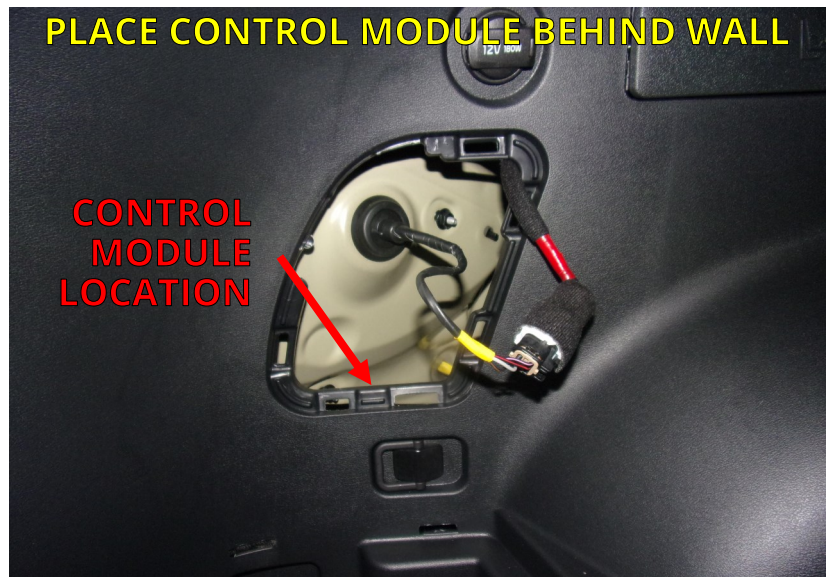

14. Open the vehicle hood. Locate and remove the auxiliary battery cover.

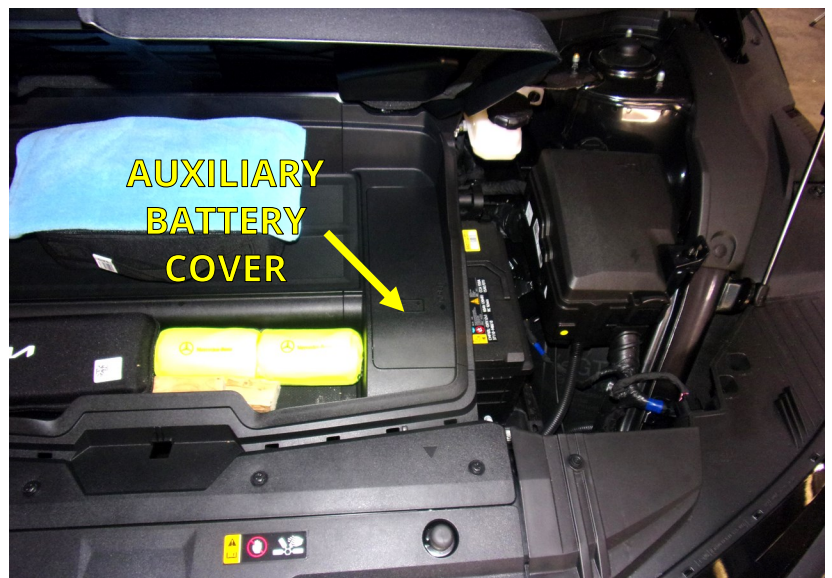



## INSTALL PASSIVE WIRING KIT CONTINUED



10mm  
SOCKET

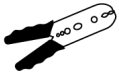

STRIPPER/  
CRIMPING  
TOOL

15. Open the positive battery terminal cover. Locate the power wire and fuse holder supplied in the wiring kit box. Remove the fuse from the fuse holder. Crimp fuse lead to power wire. Use a 10mm socket to remove (1) nut, as shown. Connect fuse ring terminal to the positive battery terminal (+) and replace the nut.

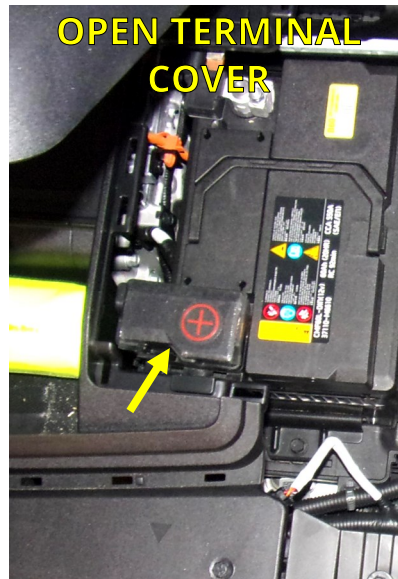

16. Route the power wire from the auxiliary battery down through the driver side of the area under the hood. Under the vehicle, route the power wire towards the rear of the vehicle on the driver side. Pass the wire above and through existing vehicle components to secure and protect the wire as much as possible.

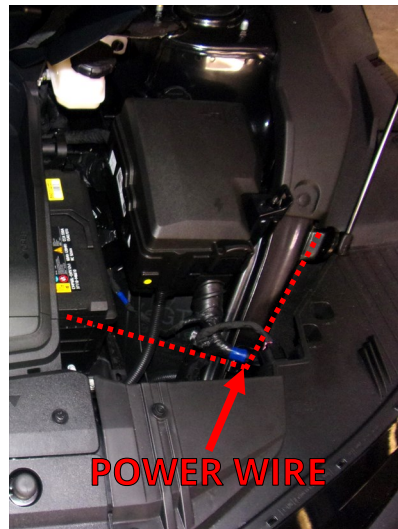

DRILL &  
3/8" BIT

17. Locate the rubber grommet underneath the rear of the vehicle on the driver side and remove it. Use a 3/8" drill bit and drill a hole through the center of the grommet. Feed the power wire through the grommet from outside to the inside of the vehicle. Retrieve the 4-way plug with wire. Pass the grommet over the wires so the plug will be on the outside of the vehicle. Pass the control module ground wire through the grommet to the outside of the vehicle. Thread the end of the wires into the hole and replace the grommet.



## INSTALL PASSIVE WIRING KIT CONTINUED

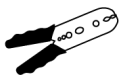

STRIPPER/  
CRIMPING  
TOOL

18. Inside the vehicle, trim the control module power wire to remove excess length. Use the included blue butt connector to crimp the power wire to the control module power wire.

**NOTICE (OPTIONAL):** The butt connector is a heat shrink connector. Apply heat to waterproof the connector after crimping.

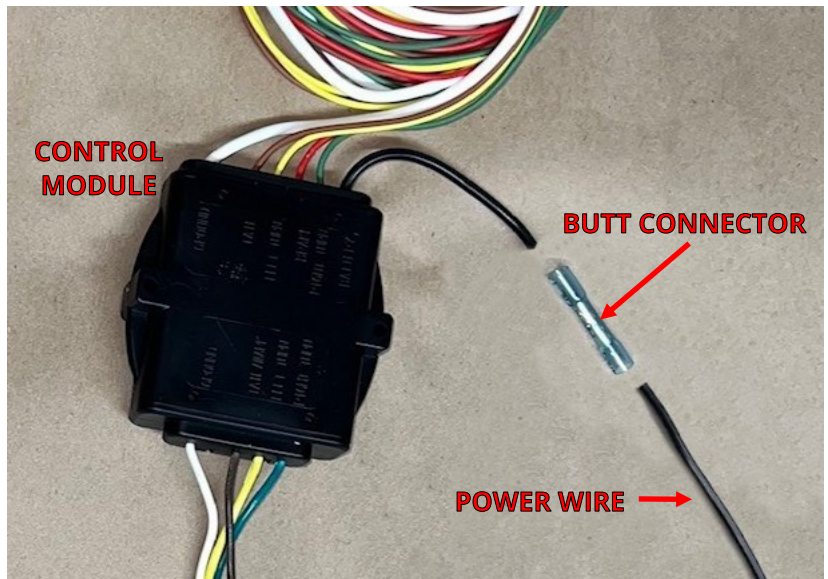

10mm  
SOCKET

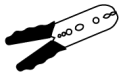

STRIPPER/  
CRIMPING  
TOOL

19. Under the rear driver side of the vehicle, locate the ground screw shown in the image. Use a socket to loosen the ground screw. Trim white ground wire so it will reach stud without excess wire. Crimp supplied fork terminal to the ground wire with a crimping tool. Secure the fork terminal to ground screw.

**NOTICE:** Loosen ground stud just enough to install fork terminal, so vehicle wiring does not lose ground.

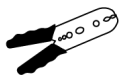

STRIPPER/  
CRIMPING  
TOOL

20. Locate the tail of the 4-way connector wire and the output side wires of the control module. Attach each similar color wire to each other using a red butt connector and crimping tool.

**NOTICE (OPTIONAL):** The butt connectors are heat shrink connectors. Apply heat to waterproof the connectors after crimping.

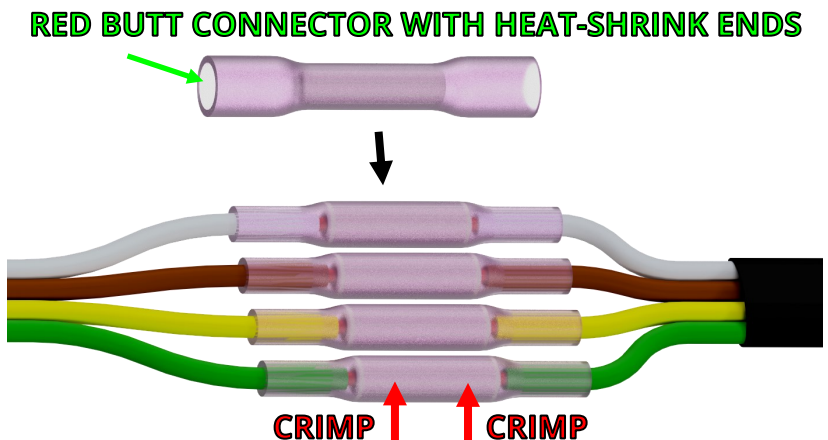

**MATCH THE WIRE COLORS AND CRIMP EACH WIRE INTO THE SIDE OF EACH BUTT CONNECTOR. APPLY HEAT TO WATERPROOF AFTER CRIMPING**

## INSTALL PASSIVE WIRING KIT CONTINUED

21. Secure harness to Stealth hitch frame with cable ties. Maintain an 18" loop from the cable tie to the 4-way plug. Add the magnetic cable holder and secure to the harness close to the 4-way plug, with a cable tie.

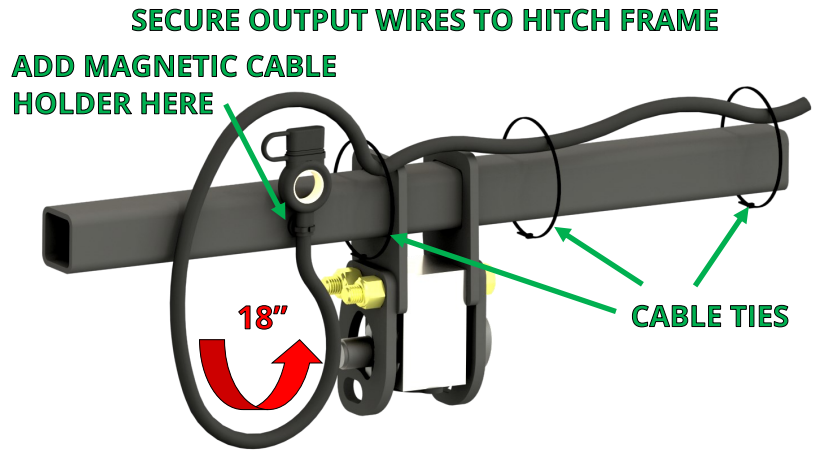

PLIERS



MULTIMETER

22. The wires on the input side of the module need to be attached to the vehicle wiring. In the driver side of cargo area, locate the indicated part of the vehicle wiring harness. Use clamp-on connectors to connect the brown and yellow input wires to wires behind taillight. (As shown in reference table on the next page.)

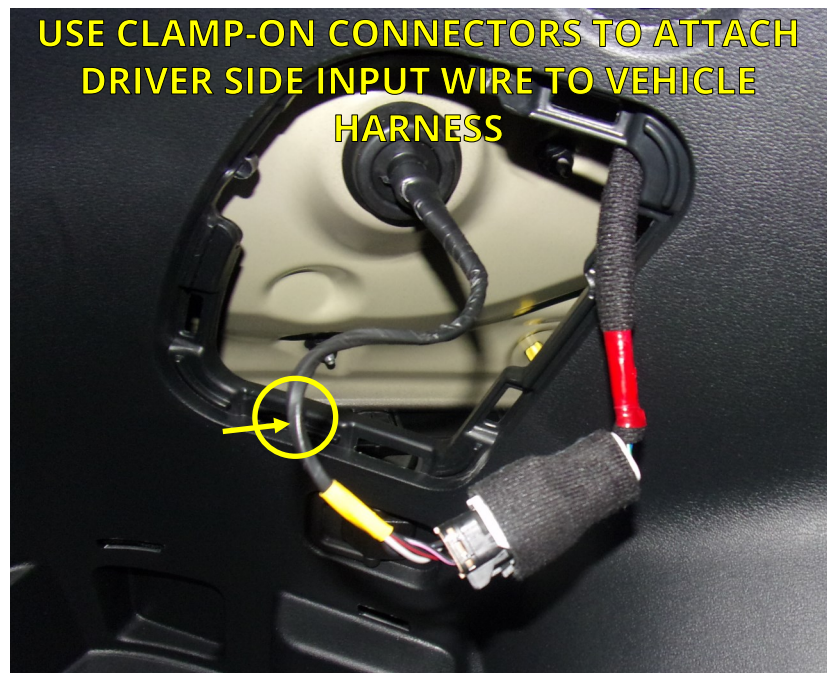

**NOTE:** Vehicles may have different wire colors than those shown. Verify circuits (wire colors) with multimeter.



PLIERS







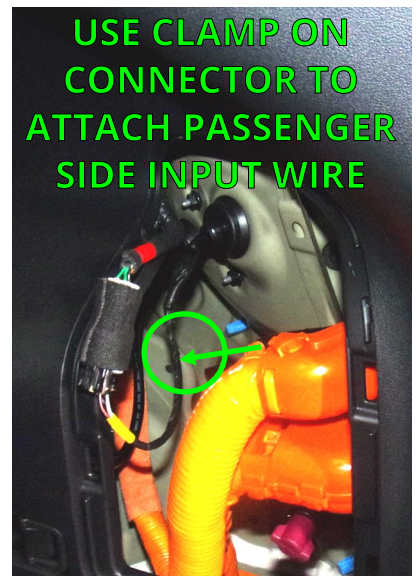
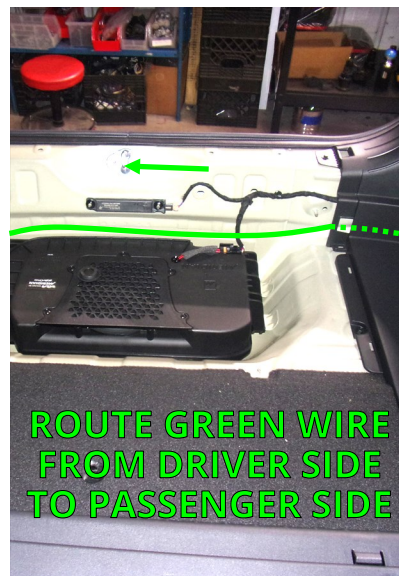



MULTIMETER

23. Route the green input wire to the passenger side of the vehicle through the cargo compartment. Locate the indicated part of the vehicle wiring harness. Remove the tape to gain access to taillight wires. Use a clamp-on connector to connect the green wire to the right turn signal wire behind the taillight. (As shown in reference table on the next page.)



**INSTALL PASSIVE WIRING KIT CONTINUED**

**CLAMP-ON CONNECTOR COLOR REFERENCE TABLE**

| SIGNAL INPUT WIRES |  |  | POWER & GROUND WIRES  |   |              |
|--------------------|--|--|---|---|--------------|
| FUNCTION           | HARNESS  | VEHICLE  |   |   |              |
| <u>LEFT TURN</u>   |  YELLOW |  BLACK/RED  | <u>12V+ (POWER)</u>   |  BLACK | BATTERY (+)  |
| <u>RIGHT TURN</u>  |  GREEN  |  BLACK/RED  | <u>GROUND</u>   |  WHITE | GROUND SCREW |
| <u>MARKER</u>      |  BROWN  |  BLACK/PINK | <b><i>NOTICE: Do not connect the red brake wire. This vehicle does not utilize a separate brake circuit. The brake signal is sent down the left and right turn circuits simultaneously.</i></b> |   |              |
| <u>BRAKE</u>       |  RED    | NOT USED   |   |   |              |

**NOTE: If two colors are listed, the first color is the dominant color.**



MULTIMETER



SILICONE

24. Reinstall the 20 Amp fuse in the harness fuse holder.
25. Test the 4-way plug using a multimeter or connect the plug to a trailer and verify that the lights and brakes work correctly.
26. Secure all wires and wiring components. Use the remaining cable ties to secure wiring so that it is not loose and will not interfere with replacement of the gravel guard. Wiring should not be visible once the vehicle is reassembled. Use the provided adhesive foam strips to secure the control module to the inside body panel. Use silicone to waterproof the grommet.



**Skip to Step 36 to complete installation.**

## INSTALL **ACTIVE** WIRING KIT CONTINUED



27. On the driver side of the cargo area, use a plastic pry tool to remove the panel, as shown.



**USE A PLASTIC PRY TOOL TO OPEN PANEL**

28. While using a flashlight, locate the 6-pin connector taped to a harness bundle inside. Carefully release the 6-pin connector from the tape and pull through the open panel.

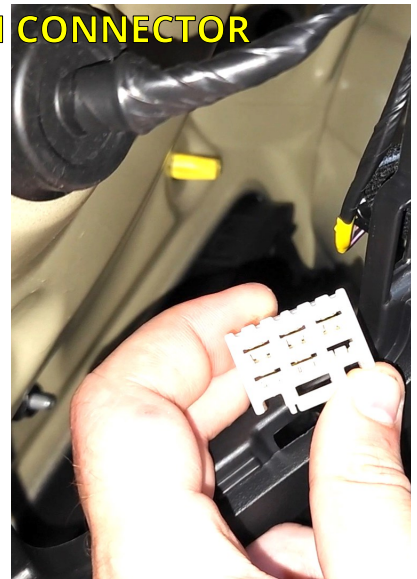
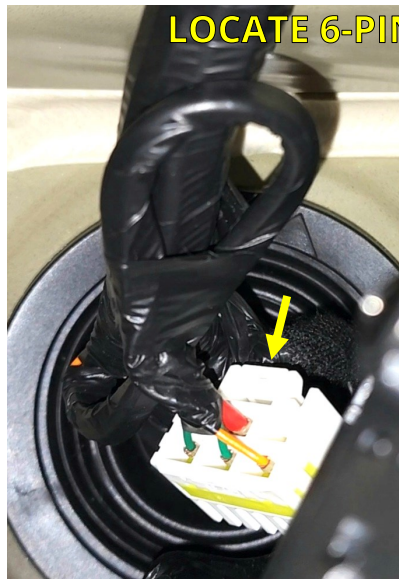

**LOCATE 6-PIN CONNECTOR**

29. Under the vehicle trunk on the driver side, locate and remove the indicated grommet. Discard the grommet.



**REMOVE GROMMET UNDER VEHICLE**

**GROMMET**

## INSTALL **ACTIVE** WIRING KIT CONTINUED



30. Inside the wiring harness kit, locate the output harness. From under the vehicle, feed the small 6-pin connector up through the hole where the grommet was removed. Seat the rubber grommet into the hole.



31. Secure harness to Stealth hitch frame with cable ties. Maintain an 18" loop from the cable tie to the 4-way plug. Add the magnetic cable holder and secure to the harness close to the 4-way plug, with a cable tie.

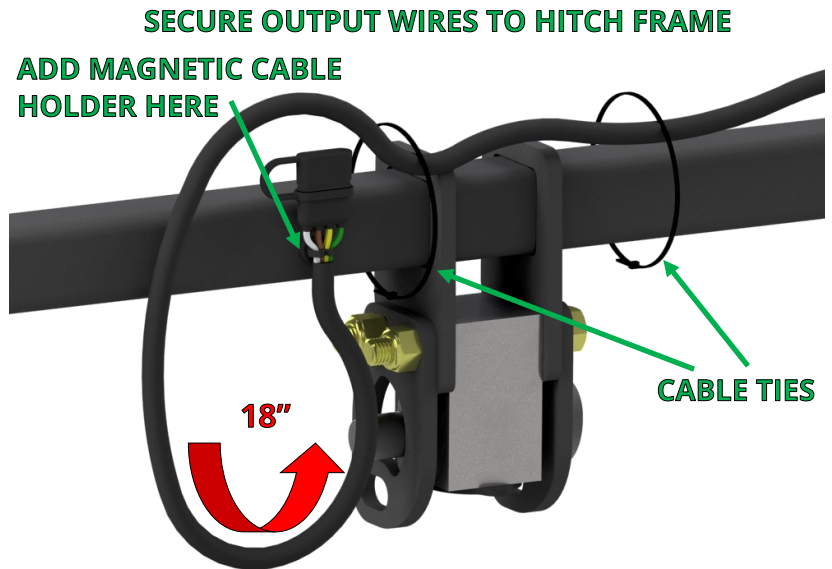

32. Inside the wiring harness kit, locate the input harness with fuse. Temporarily remove the fuse from the fuse holder. Plug the input harness 6-pin male plug into the female plug which was taped behind the panel. The two plugs should lock together.



## INSTALL **ACTIVE** WIRING KIT CONTINUED

33. Inside the wiring harness kit, locate the control module. Plug the 7 pin input harness connector and 6 pin output harness connector into the control module as shown. Press each plug into place until it locks in. Replace the fuse in the fuse holder.

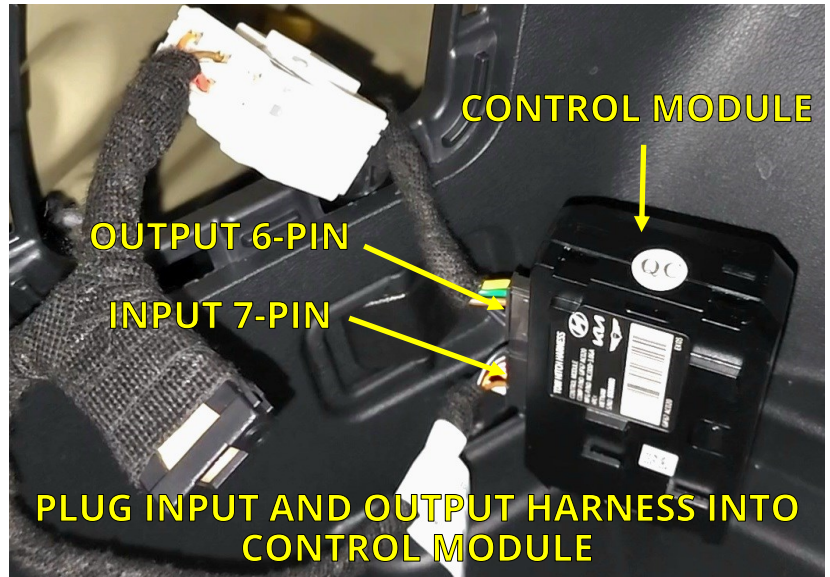

34. Use the double sided tape to attach the control module to a flat area of metal inside the panel. Secure all loose wires with cable ties.



MULTIMETER

35. Test the 4-way plug using a multimeter or connect the plug to a trailer and verify that the lights and brakes work correctly. Secure all wires and wiring components. Use the remaining cable ties to secure wiring. Wiring should not be visible once the vehicle is reassembled.

## CUT ACCESS TO LATCH BLOCK

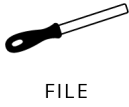

36. Use a Dremel tool to cut out the gravel guard, as shown. Use file to smooth out the cut.

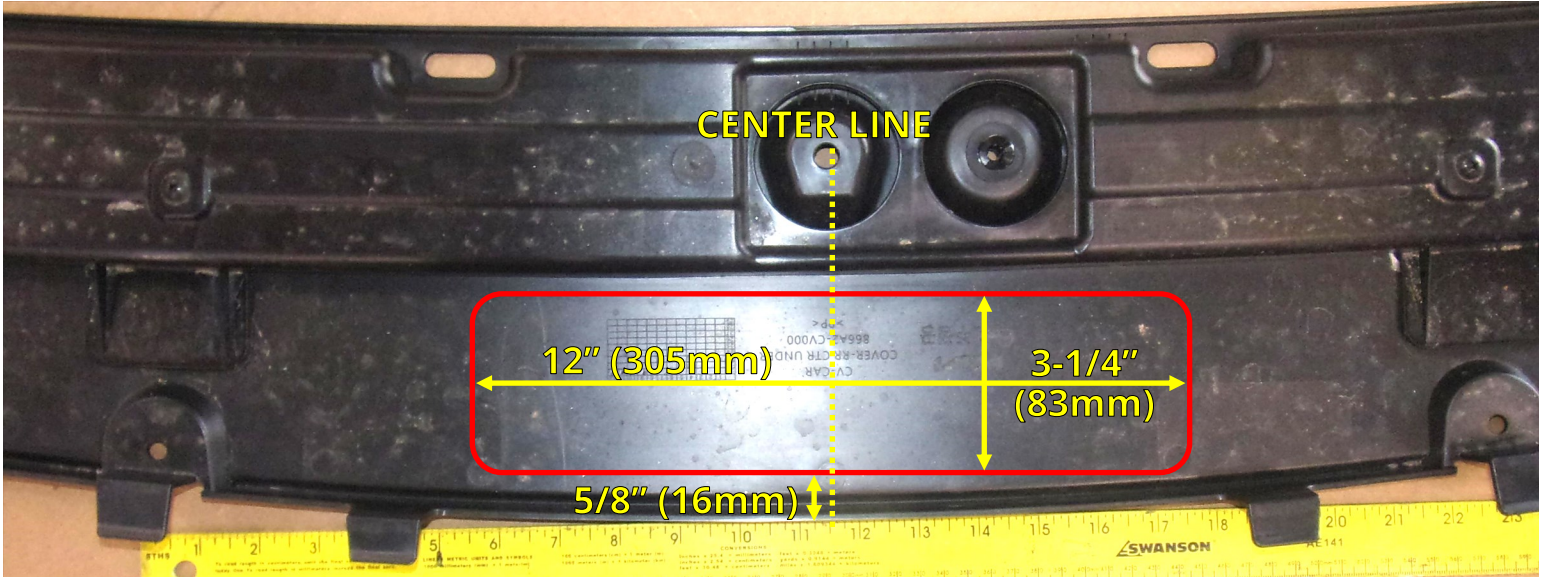

## REINSTALL VEHICLE COMPONENTS

37. Reattach and secure the gravel guard, and other vehicle components in reverse order. Refer to Steps 1-2.





## FINAL VEHICLE EXAMINATION

38. Examine the body panels to ensure that they are in a pre-installation condition. Test the electronic functions of the vehicle. Correct any inconsistencies.
39. Ensure that hitch components work properly.
  - **Verify that the lock works correctly.** Push in the safety lock on the latch block then unlock with key. The lock should slide back out with the key when unlocked.
  - **Verify that each accessory can be installed correctly.** Use the following steps to install and remove each accessory that will be used with the hitch. (*Rack Receiver and Ball Mount if purchased.*)
    1. Prepare latching mechanism. Turn handle clockwise if needed.
    2. Firmly insert "post" of accessory into latch block until handle releases indicating that the accessory is latched.
    3. Push in the safety locking pin until it fully engages. The locking pin prevents the handle from turning when pushed in, and confirms that the block is securely latched onto the accessory. The safety locking pin will not depress if the accessory is not fully latched.
    4. Use key to release safety locking pin.
    5. While holding on to the accessory, rotate handle clockwise to release and remove the accessory.
  - **Verify that no part of the accessories come into contact with the body of the vehicle.**

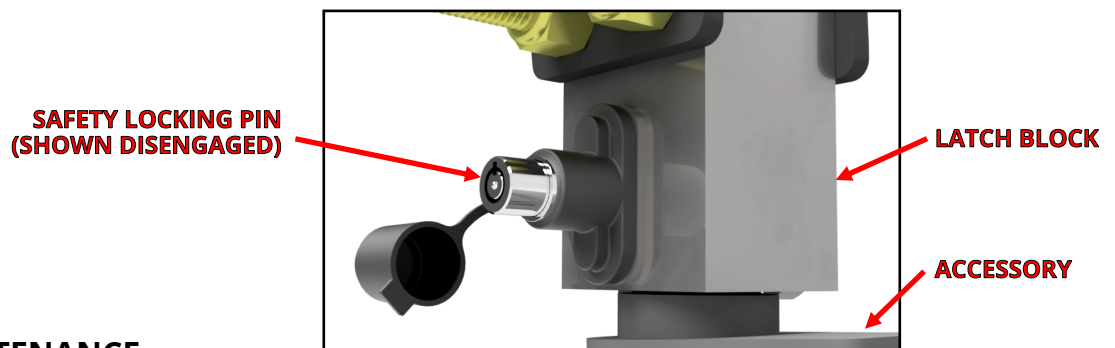

## PRODUCT USE AND MAINTENANCE

**NOTICE: If the hitch is being installed by a professional, the installer is responsible for training the end user in the use and maintenance of the product.**

- **Accessory installation procedure:**
  1. Prepare latching mechanism. Turn handle clockwise if needed.
  2. Firmly insert "post" of accessory into latch block until handle spins counter-clockwise indicating that the accessory is latched.
  3. Always depress the safety locking pin and check that it has fully engaged.
- **Never use any accessory with the safety lock disengaged.** Until the safety locking pin is engaged, the handle is able to turn. A fully engaged safety locking pin is confirmation that the accessory is properly latched into the latch block.
- **Never use the rack receiver for towing.** The rack receiver accessory is only to be used with payload carrying products, such as bike racks or luggage racks.
- **Before each use, give the post of the accessory a light coating of lithium based grease.**
- **Before each use, inspect the hitch to ensure that all bolted connections are secure and that no cracks or damage are present.** Do not tow with the hitch if cracks or damage outside of normal wear is found.
- **Remove the Stealth accessories from the latch block after each use.** Do not leave accessories plugged in for extended periods of time.

SHR63002\_(pn 2120-63002-2) 05 02 2024