



# HITCH INSTALLATION INSTRUCTIONS

MAKE: YEARS: MODEL/TRIM:  
 HYUNDAI 2022 - 2024 IONIQ 5

www.stealthhitches.com 833-694-4824

RACK RECEIVER KIT#: **SHR62003**

COMPATIBLE WITH TOW KITS: **SHT25050, SHT25064A & SHT25059**

**2" RACK RECEIVER MAXIMUM PAYLOAD:** 350 LBS

**MAXIMUM TOW RATING:** 3500 LBS

**MAXIMUM TONGUE WEIGHT:** 350 LBS

**AUSTRALIA AND NEW ZEALAND ONLY:**

**2" RACK RECEIVER MAX. PAYLOAD:** 100 KG (221 LBM)

**MAX. TOW RATING:** 1,000 KG (2,205 LBM) AS4177.1 - 2004

**MAX. TONGUE WEIGHT:** 100 KG (221 LBM)

## UNDER VEHICLE TRIMMING:

HEAT SHIELD: **NO** FASCIA: **YES**  **READ ALL INSTRUCTION WARNINGS AND LABELS**  
 GRAVEL GUARD TRIMMING: **YES**

 **NO WELDING, METAL DRILLING OR VISIBLE TRIMMING REQUIRED**



## PARTS SUPPLIED WITH RACK RECEIVER KIT:

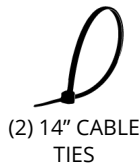
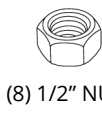
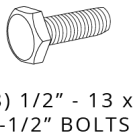
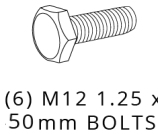
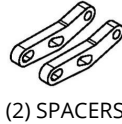
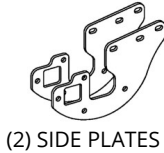
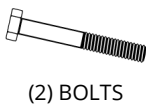
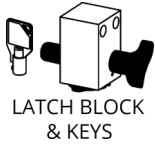

## ADDITIONAL PARTS FOR TOW KIT:

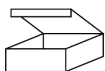
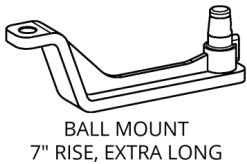

## TOOLS REQUIRED:



## ADDITIONAL TOOLS FOR ACTIVE & PASSIVE TOW KITS:



## ADDITIONAL TOOLS FOR PASSIVE TOW KIT:



**RACK RECEIVER INSTALLATION:** USE STEPS 1-20 & 51-55  
**PASSIVE TOW KIT INSTALLATION:** USE STEPS 1-40 & 51-55  
**ACTIVE TOW KIT INSTALLATION:** USE STEPS 1-25 & 41-55

 **Australia and New Zealand customers installing a Tow Kit see special instructions on bottom of Page 8.**

# <THESE INSTRUCTIONS MUST BE GIVEN TO THE END USER>

NOTICE: Installation of Stealth products may or may not require the addition of a wiring harness to the vehicle.

- The Rack Receiver only product does not require adding a wiring harness.
- The Rack Receiver plus Tow Kit requires the addition a wiring harness that is compatible with the vehicle's wiring. Depending on the vehicle, the harness will be one of two types, "Active" or "Passive." The wiring section of the instructions will indicate which wiring harness style is being used and how to install it.
- The **Active Harness** plugs into the vehicle's wiring so that the vehicle's computer can communicate with the trailer wiring. This allows certain functions such as cameras or backup alarms to continue to operate as designed.
- The **Passive Harness** is independent of the vehicle's computer and communication system. The module of the harness is powered directly from the battery rather than the vehicle's wiring harness. The module monitors the output signals from the vehicle's lights. It then powers and activates the trailer lighting accordingly.









**INSTALLATION NOTE:** In most instances, these instructions will only outline disassembly of vehicle components. Re-installation of components will require the installer to retain vehicle hardware and work through disassembly instructions in reverse order. When installation is complete, double check that all vehicle components have been replaced and are secured.

## IMPORTANT SAFETY NOTICE FOR STEALTH HITCH INSTALLERS AND CUSTOMERS.

Read all installation and operating instructions along with all labels before installing or using this product. Do not perform any installation or towing procedures without fully understanding the correct tools and actions for all steps. Call for support if needed.

### **WARNING**

### **Failure to comply with the safety information in these instructions could result in serious injury or death.**

-  Do not modify this product in any manner. Doing so could alter its integrity and lead to a loss of attachment between the trailer and the tow vehicle.
-  Adding Stealth hitch components to the chassis of any vehicle can be hazardous. There is potential for unexpected combustion of fuel, electric shock, burns, shifting or falling of unstable vehicle, damage to vehicle, injury from tool usage and many other hazards. This installation must be completed by someone who is aware of the hazards involved. This person must be knowledgeable of proper safety procedures for a vehicle modification of this nature, and for usage of the equipment required to perform the installation.
-  Without proper knowledge, towing can be a dangerous activity. Understand all the risks involved with towing before proceeding. For information on towing safety, see "**The Trailer Handbook: A Guide to Understanding Trailer and Towing Safety**" from the National Association of Trailer Manufacturers, [www.NATM.com](http://www.NATM.com) and your trailer and tow vehicle manufacturer's owner's manual.
-  Do not exceed tow or tongue rating of coupler, tow or tongue rating of hitch, or tow or weight ratings of tow vehicle or trailer. See vehicle and trailer manufacturer information for ratings. Exceeding these ratings may cause damage to towing components or loss of attachment between the trailer and vehicle.
-  While installation is being performed, check for signs of damage or excessive corrosion. Do not install hitch components over vehicle parts that are broken or have compromised structural integrity.
-  This product was designed to fit vehicles in their original, "as manufactured" condition. Compatibility with vehicles having replacement parts, or other modifications is not guaranteed. Inspect vehicle for modifications before installation of this product.
-  Some accessories, like the rack receiver, are not rated for towing. Do not use any accessories without proper knowledge of their use.
-  A visual inspection of the hitch should be performed before each use. Regularly check that all connections are secure, including those that secure the hitch to the vehicle. Check for cracks or damage to the hitch. Do not use the hitch if cracks or damage outside of normal wear is found. Using a hitch that has unsecure connections and/or cracks or damage could result in damage to the tow vehicle, trailer, towing components and loss of attachment between the tow vehicle and trailer.
-  Stealth hitches are not compatible with any weight distribution or sway control products. Adding additional products to the trailer or chassis which modifies the function of the Stealth hitch may cause hitch failure.

**NOTICE:** Installation of hitch requires removal of vehicle parts and interaction with vehicular electronics. Before installation, check the condition of body panels and note any locations where panels are not flush. Check the electronic functions of the vehicle, such as: headlights, taillights, turn signals, cameras, backup sensors, Parking Distance Controller (PDC), foot activated cargo access, etc. It is the responsibility of the installer to restore the fit and function of the vehicle.

## GAIN ACCESS TO MOUNTING AREA



1. Open the vehicle cargo area. Use a plastic pry tool to remove both taillight covers. Insert the pry tool into the small slot on top of the cover, as shown. Pry upward to release first clip. Next locate the (2) slots on the side of the cover. Pry inward to release the clips. Remove the plastic covers.

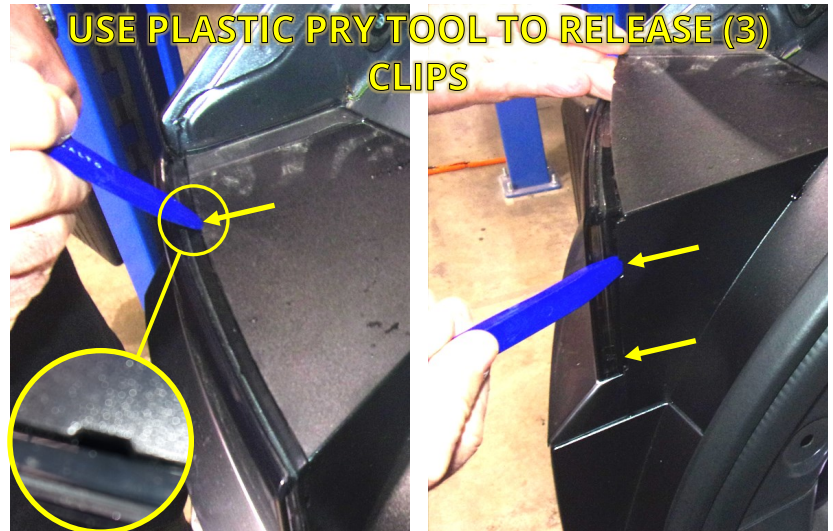

-or-



10mm & 8mm  
SOCKETS

2. Use a Phillips head screwdriver or sockets to remove (3) screws securing the taillights to the fascia. Slide the taillights rearward to dislodge and gain access behind the lights.

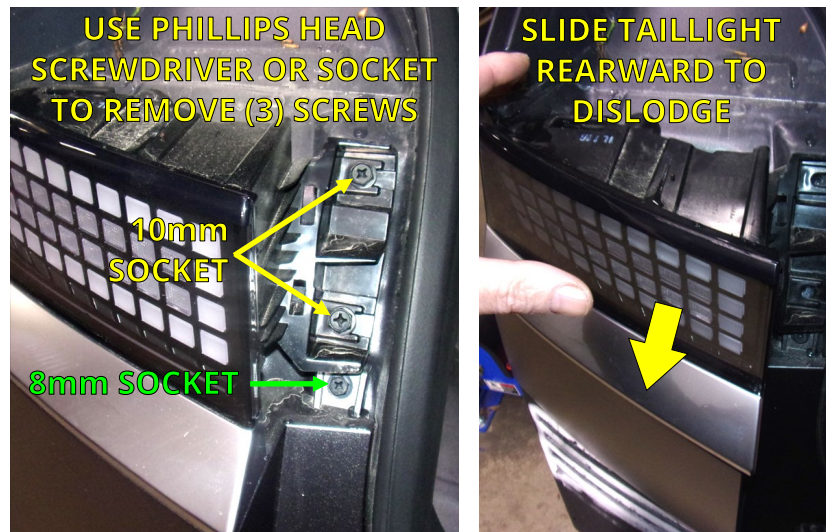

3. On the back of the each taillight, turn the plug cover counter-clockwise to open. Inside the cover push down on the taillight connector release clip to unplug light from vehicle.

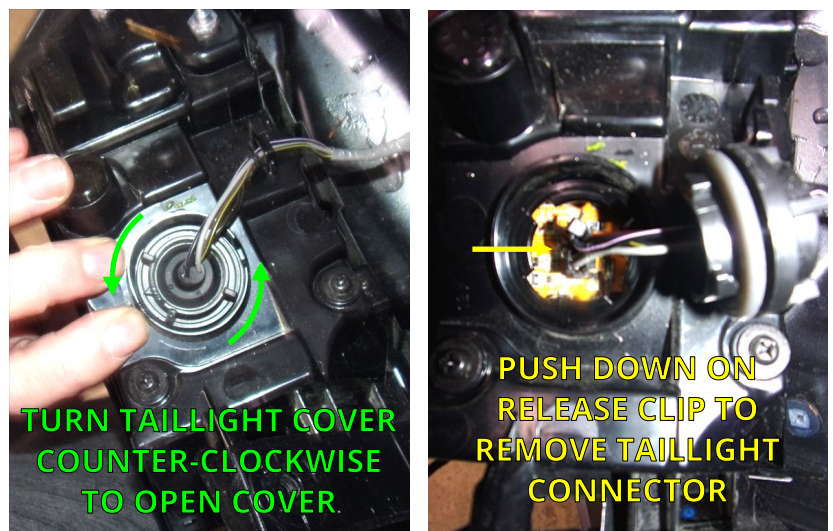



## GAIN ACCESS TO MOUNTING AREA CONTINUED



90 DEGREE PICK

4. In the areas below where the lights were removed, use a 90 degree pick tool to remove (2) rivets per side.
5. Under the vehicle, behind the tires, use a 90 degree pick tool to remove (1) rivet on each side of the vehicle securing the wheel well liner to the bottom of the fascia.

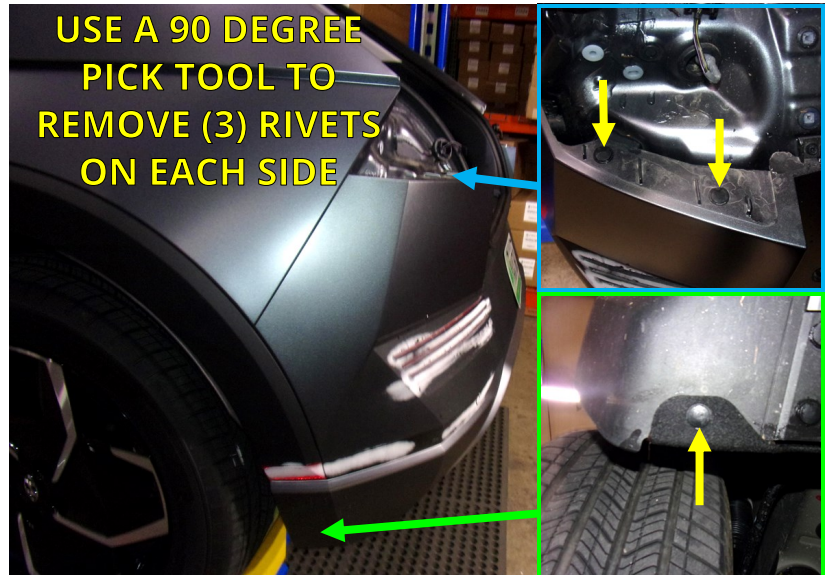

PHILLIPS HEAD SCREWDRIVER

-or-



10mm SOCKET

6. Inside each wheel well, behind the tire, use a 10mm socket or screw driver to remove (1) screw behind the tire, where shown.
7. Use a Phillips head screwdriver or socket to remove (3) screws attaching the wheel well liner to the fascia, where shown.

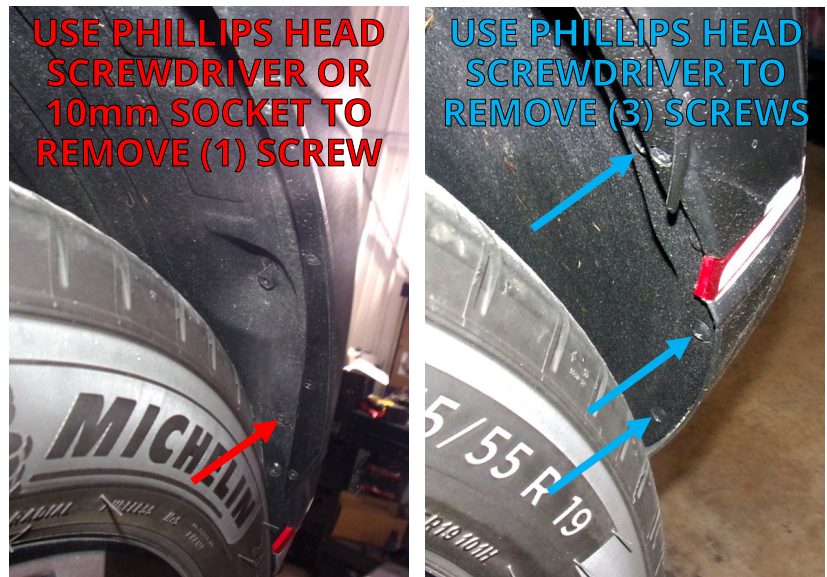

90 DEGREE PICK

8. Underneath the rear of the vehicle, use a 90 degree pick tool to remove (10) plastic rivets securing the gravel guard. Remove the gravel guard.





## GAIN ACCESS TO MOUNTING AREA CONTINUED



PHILLIPS HEAD  
SCREWDRIVER

9. With the gravel guard removed, locate (3) Phillips head screws inside the bottom of the fascia. Remove the screws.

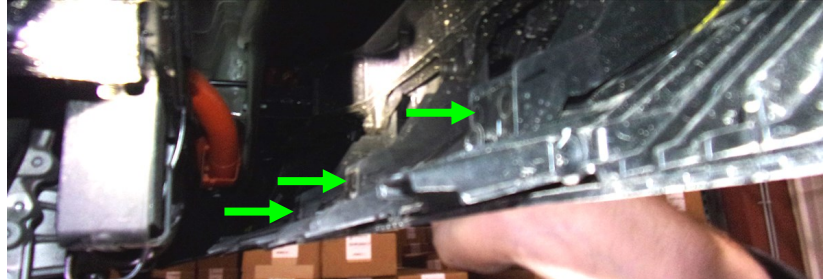
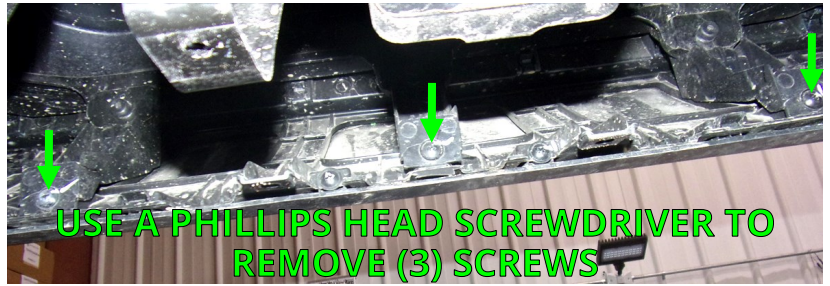

PLASTIC  
PRY TOOLS

10. With outward pressure, pull on the plastic wheel well trim piece. Use a plastic pry tool to release (2) clips on the outer edge and (3) more clips behind the trim piece. Repeat on other side of vehicle.

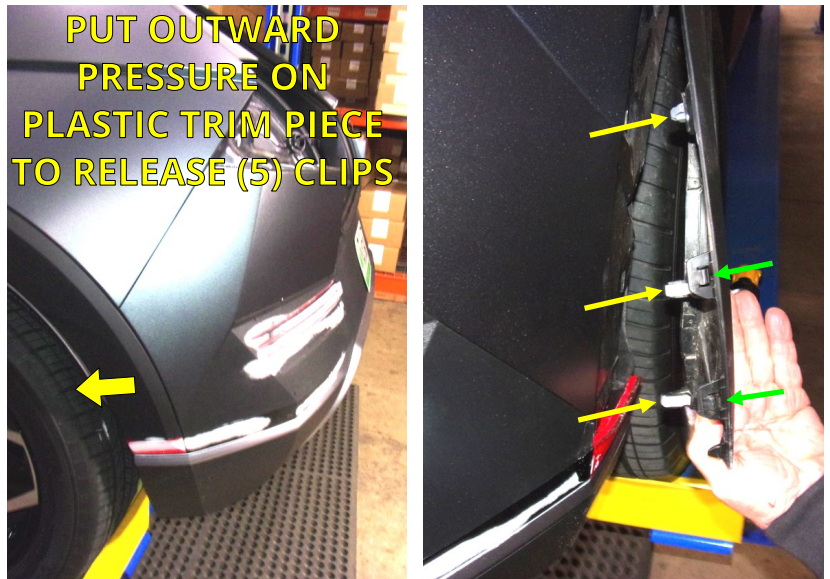

PLASTIC  
PRY TOOLS

11. The fascia is clipped to the vehicle body directly behind the wheel wells. Put outward pressure on the fascia, while sliding the fascia upward in line with the seams. The upward pressure will "push down" on the angled cups in the seam and release them. A plastic pry tool can be used to push down on the clips if they do not release. Repeat on other side of the vehicle. Keep the fascia close to the vehicle.





## GAIN ACCESS TO MOUNTING AREA CONTINUED



12. Through the small gap between the vehicle and the edge of the fascia, use a pry tool to remove (2) rivets on each side inside the fascia.

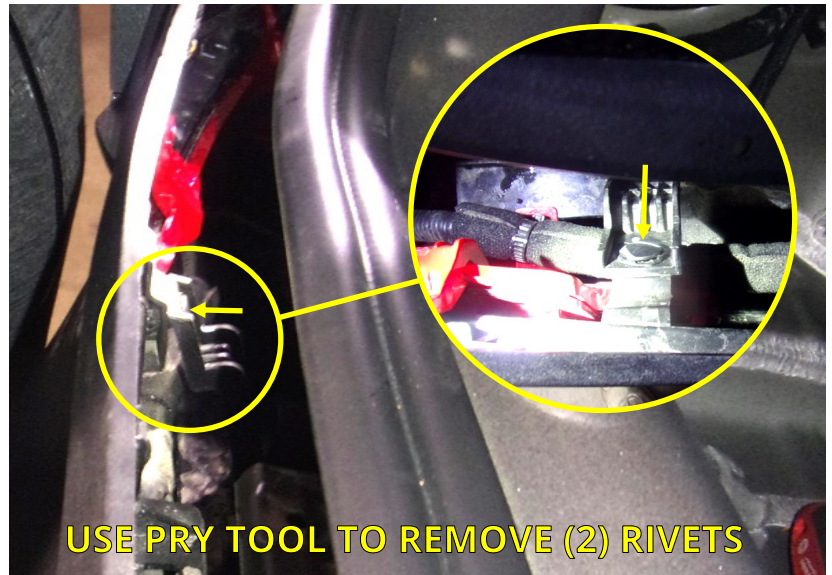

13. While continuing to support the fascia, unplug the sensor on top of the fascia support beam, where shown.

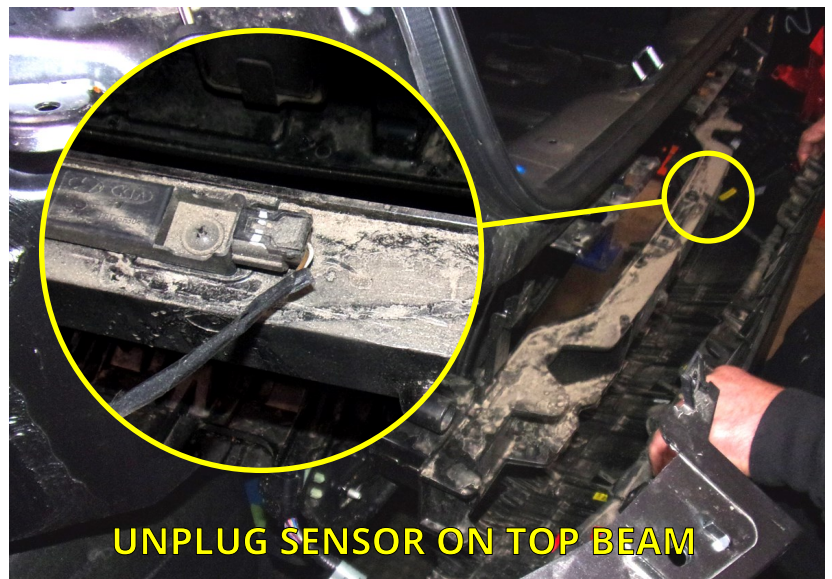

14. This step requires a partner. Pull the fascia rearward enough to access the (1) sensor plug on the driver side. Press down on the clips to unplug the sensor plugs. Remove the fascia completely.

**NOTICE:** Carefully remove the fascia and place on a blanket or pad.

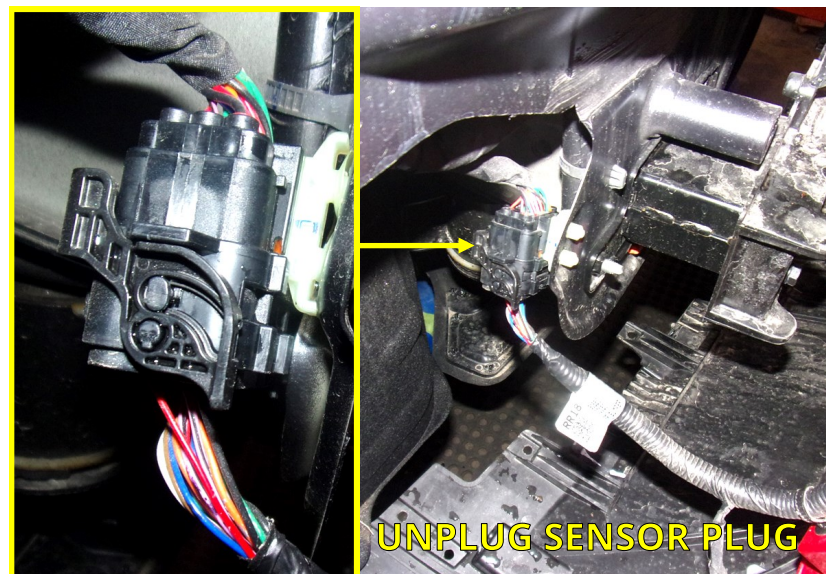



## GAIN ACCESS TO MOUNTING AREA CONTINUED



PHILLIPS HEAD  
SCREWDRIVER

- Using a screwdriver, locate and remove the (3) fascia support brackets, where shown. Discard the (1) middle support bracket, it will not be reinstalled later.



## INSTALL STEALTH HITCH

- Retrieve (3) M12 bolts from the bolt bag. Locate the (3) holes on each side of the vehicle frame near the rear of the vehicle. Screw a bolt into each hole. This will help ensure that there are no obstructions in the hole. If the bolt will not easily thread into any hole, clean the threads with an M12-1.25 thread chaser.

**NOTICE:** There are 1/2" bolts included in the bolt bag. Do not thread the 1/2" bolts into the vehicle frame, doing so may damage the threads.

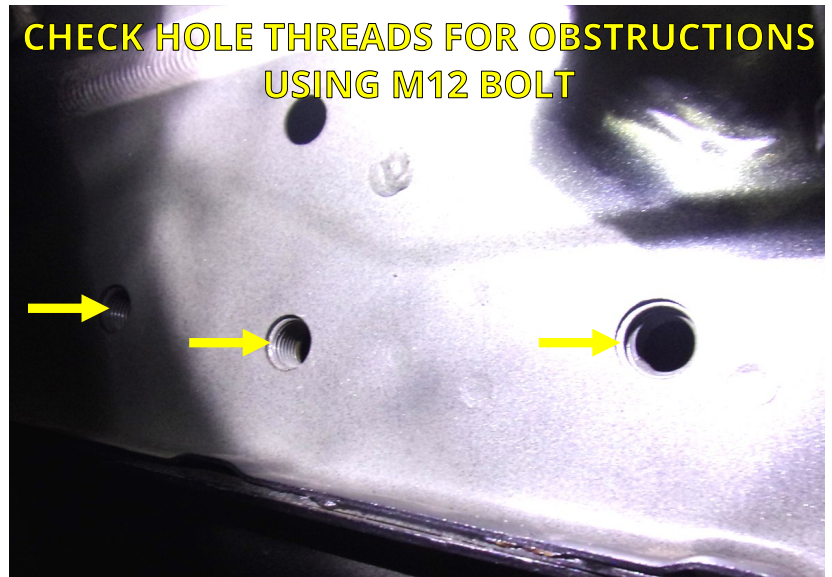

19mm  
SOCKET

- Using (3) M12 bolts, 1/2" lock washers and 1/2" flat washers loosely attach the side plate and spacer to the outside of the vehicle frame, as shown. Repeat on other side of vehicle.

**NOTICE:** Do not tighten hardware at this time.

**NOTE:** Use the provided adhesive foam strip to attach the spacers to the side plates before installation to simplify procedure.

(3) M12 BOLTS,  
(3) 1/2" LOCK WASHERS  
(3) 1/2" FLAT WASHERS

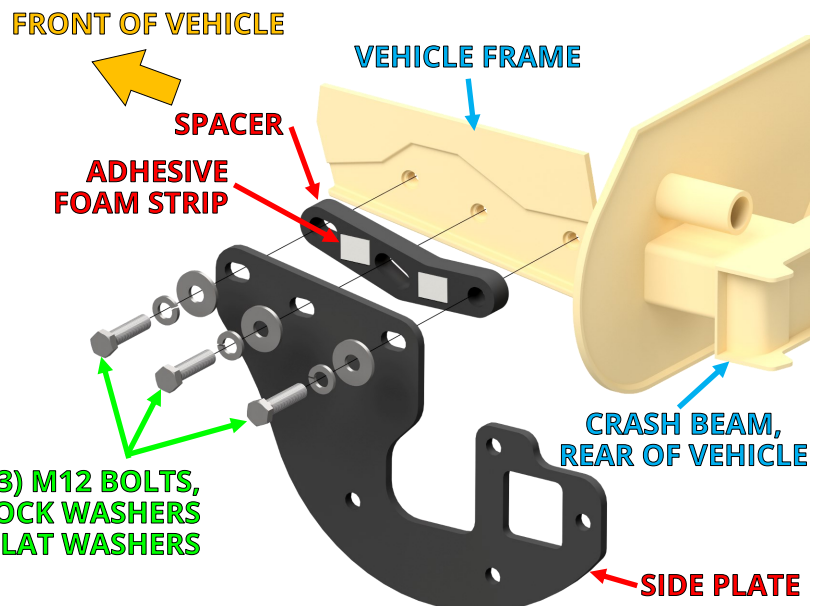

## INSTALL STEALTH HITCH CONTINUED



19mm  
SOCKET



TORQUE  
WRENCH

18. Retrieve the Stealth hitch frame. Raise the frame between the side plates. Attach the frame to the side plates using (8) 1/2" bolts, 1/2" lock washers, and 1/2" nuts, as shown.

19. Torque the M12 bolts to 85 ft.-lbs. Next, torque the 1/2" bolts and nuts to 100 ft.-lbs.

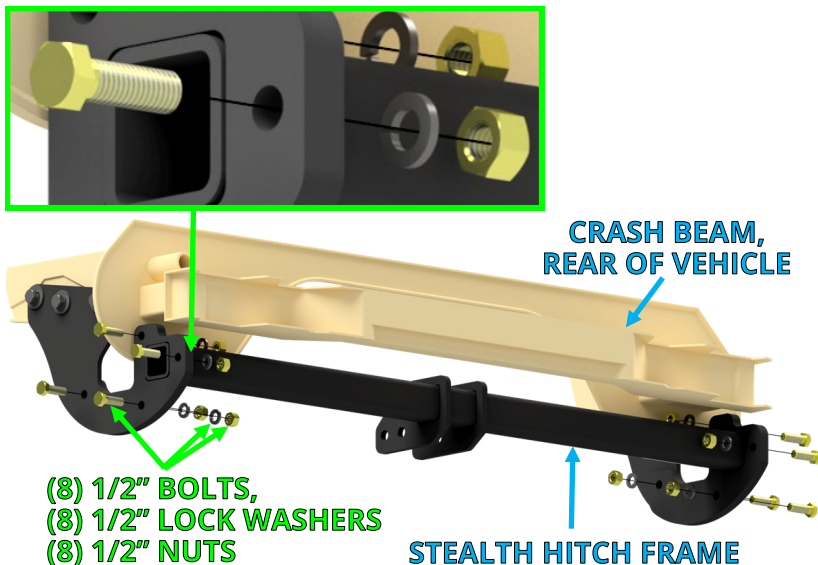

## MOUNT LATCH BLOCK



15/16"  
SOCKET



15/16" OPEN  
END WRENCH



TORQUE  
WRENCH

20. Installation of the latch block varies depending on which kit you are installing.

- **Rack Receiver Kit:** Install the latch block with (2) 5/8"-11 x 5" bolts and (2) 5/8" nylock nuts. Tighten each bolt to 150 ft.-lbs.
- **Tow Kit:** Install the latch block and (2) chain hooks with (2) 5/8"-11 x 5" bolts and (2) 5/8" nylock nuts. Tighten each bolt to 150 ft.-lbs.

**NOTICE:** Keys are packaged within the latch block, remove keys and store in safe location.

### RACK RECEIVER KIT INSTALL

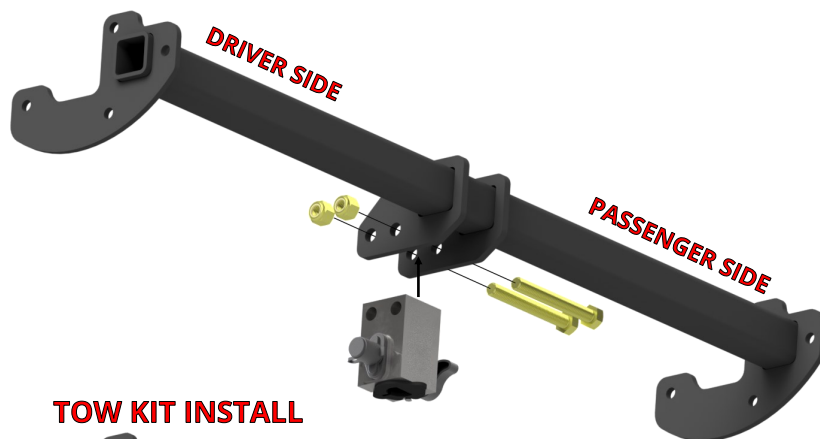

### TOW KIT INSTALL

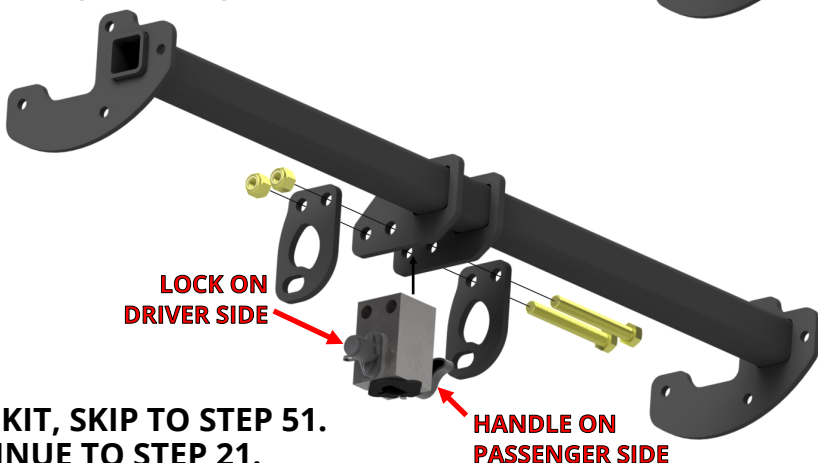

**IF INSTALLING A RACK RECEIVER KIT, SKIP TO STEP 51.  
IF INSTALLING A TOW KIT, CONTINUE TO STEP 21.**

## SPECIAL NOTICE FOR Australia and New Zealand customers

- **NOTICE:** Tow kit SHT25059 is made specifically for the Australia and New Zealand market and contains a 50mm Ball. Stealth does not provide a wiring harness with this tow kit (skip Steps 21-40). Electrical plug connections must be sourced independently.



## INSTALL WIRING KIT

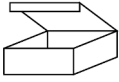

PASSIVE OR ACTIVE WIRING HARNESS KIT BOX

21. Locate the wiring kit box. Review the contents of the box against the list below to check for missing components.

- **The passive wiring kit** uses a control module to manage the functions of the trailer lighting. The module has an “input” side that receives power from the vehicle’s battery and signals from the vehicle’s taillights. The “output” side of the module delivers this information to the 4-way plug, see *passive harness diagram*. The control module is connected to the vehicle’s battery and taillight wiring as outlined in the next steps.
- **The active wiring kit** uses a Kia computer control module to manage the functions of the trailer lighting. The module will connect to the vehicle through an included wire harness. The harness has an “input” side that receives power and signals from the vehicle’s electronic systems and delivers them to the control module. The “output” side of the harness delivers this information from the control module to the 4-way plug. The harness and control module installation are outlined in the next steps.

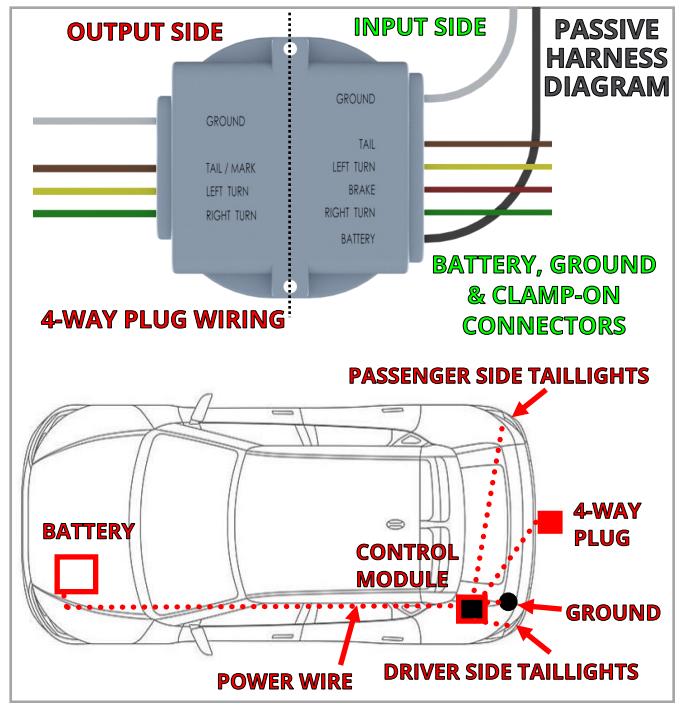

### PASSIVE WIRING KIT BOX

#	DESCRIPTION	QTY
1	4-WAY PLUG WITH WIRE	1
2	CONTROL MODULE	1
3	4-WAY CONNECTOR COVER	1
4	CABLE TIE - 8"	8
5	CABLE TIE - 14"	2
6	MAGNETIC CABLE HOLDER	1
7	M8 SERRATED FLANGE NUT	1
8	FORK TERMINAL	1
9	ADHESIVE FOAM STRIP	2
10	BUTT CONNECTOR (BLUE)	1
11	BUTT CONNECTOR (RED)	4
12	CLAMP-ON CONNECTORS	4
13	POWER WIRE	1



### ACTIVE WIRING KIT BOX



#	DESCRIPTION	QTY
1	OUTPUT HARNESS	1
2	INPUT HARNESS W/ FUSE	1
3	CONTROL MODULE	1
4	CABLE TIE - 8"	9
5	CABLE TIE - 14"	2
6	ADHESIVE FOAM STRIP	2
7	MAGNETIC CABLE HOLDER	1

## INSTALL WIRING KIT CONTINUED

22. Inside the rear cargo area, lift up the floor panel and remove.



23. Remove the luggage mat from the cargo area.

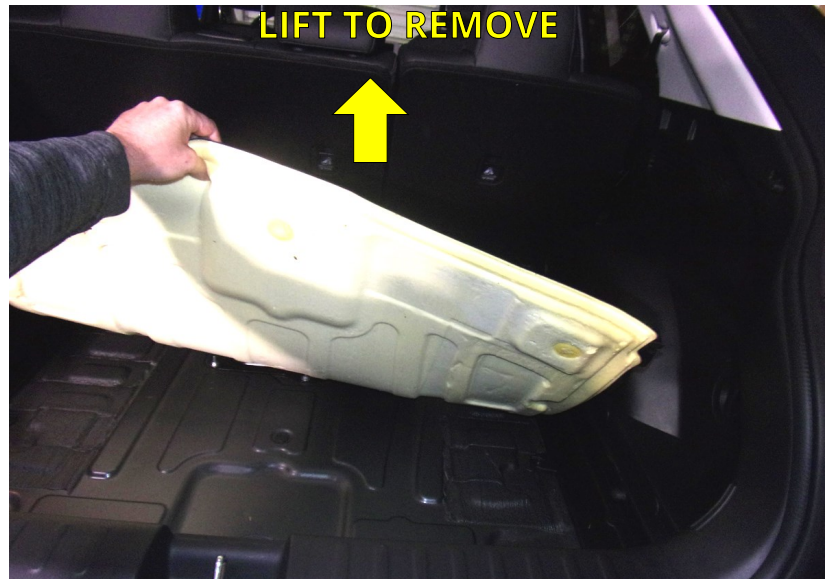

24. Use a 90 degree pick tool to remove (2) plastic rivets securing the rear threshold, as shown. Lift up on the threshold and remove.



90 DEGREE PICK

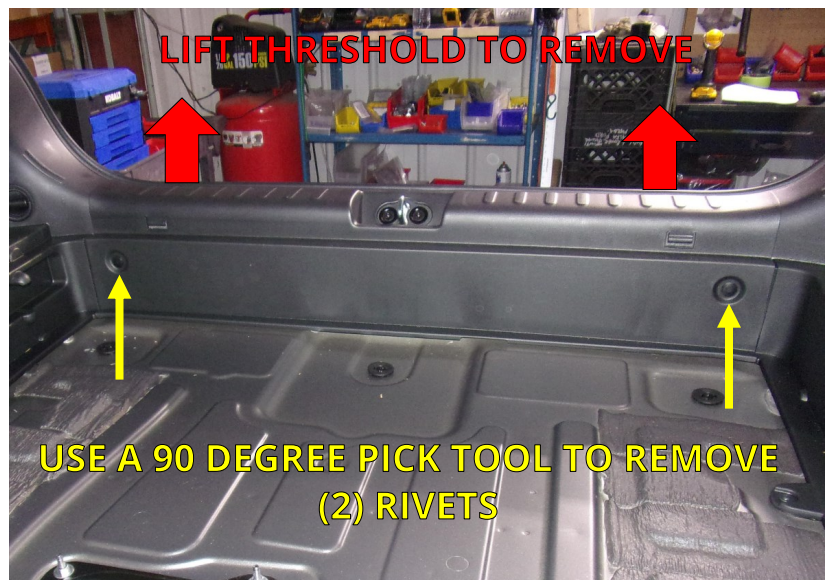



## INSTALL WIRING KIT CONTINUED



14mm  
SOCKET

25. Fold the second row seats forward. Loosen the (4) nuts securing the divider panel with a socket. Remove the divider panel.

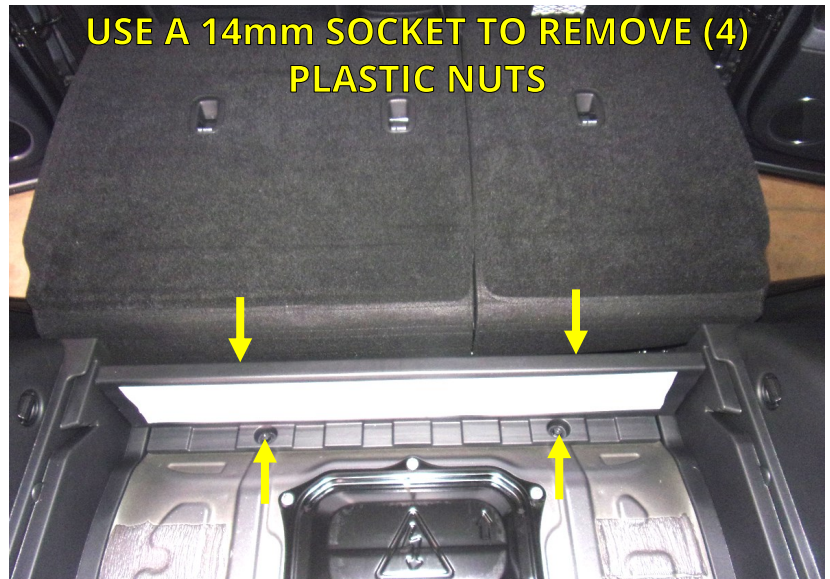

**IF INSTALLING A PASSIVE TOW KIT, CONTINUE TO STEP 26.  
IF INSTALLING AN ACTIVE TOW KIT, SKIP TO STEP 41.**

## INSTALL PASSIVE WIRING KIT



PHILLIPS HEAD  
SCREWDRIVER



PLASTIC  
PRY TOOLS

26. Use a screwdriver to remove (3) screws securing the trunk trim panel. Use a plastic pry tool to dislodge the trim panel. Repeat on other side of cargo area.



27. Dislodge the driver side panel. Behind the panel unplug the (2) connectors attached to the light and 12V outlet. Using the provided adhesive foam strips, place the harness control module inside the compartment where shown (red arrow).



**CONTROL MODULE  
LOCATION**

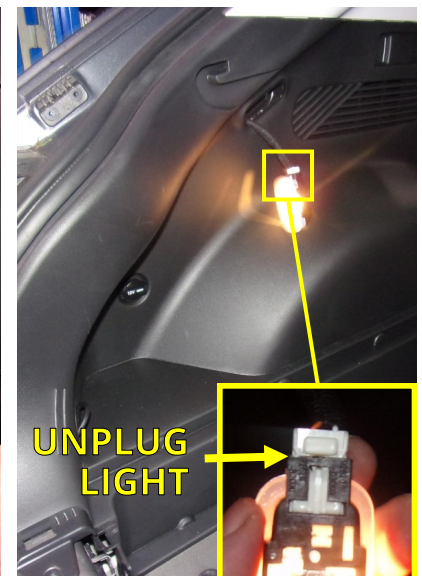



## INSTALL PASSIVE WIRING KIT CONTINUED

28. Open the vehicle hood. Locate and remove the auxiliary battery cover.

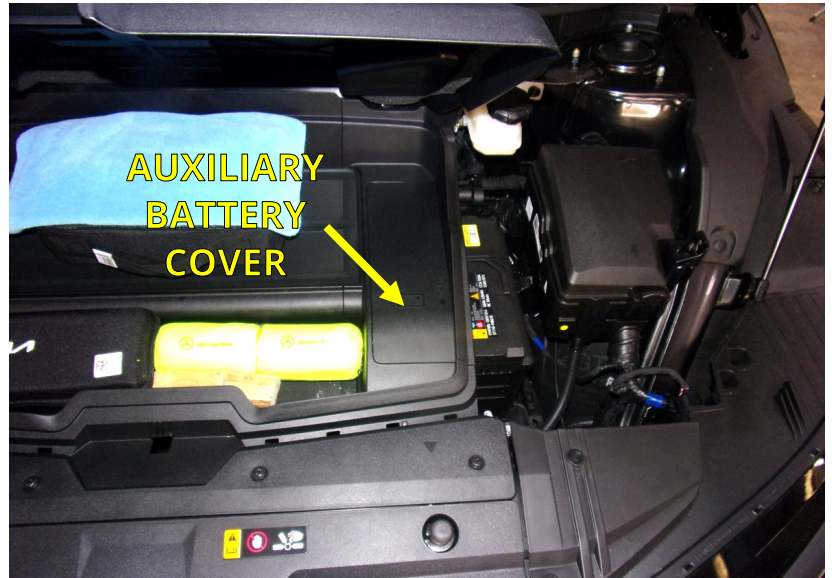

10mm  
SOCKET

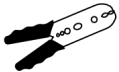

STRIPPER/  
CRIMPING  
TOOL

29. Open the positive battery terminal cover. Locate the power wire and fuse holder supplied in the wiring kit box. Remove the fuse from the fuse holder. Crimp fuse lead to power wire. Use a 10mm socket to remove (1) nut, as shown. Connect fuse ring terminal to the positive battery terminal (+) and replace the nut.

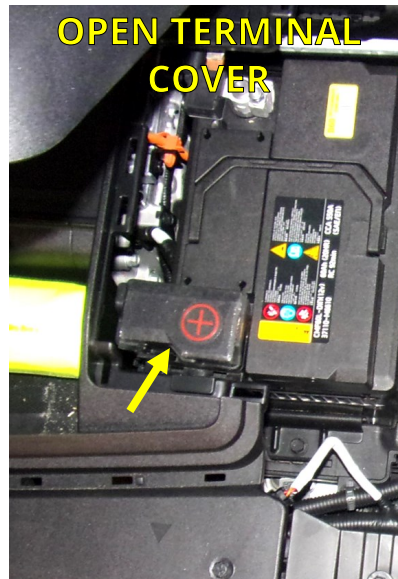

30. Route the power wire from the auxiliary battery down through the driver side of the area under the hood. Under the vehicle, route the power wire toward the rear of the vehicle on the driver side. Pass the wire above and through existing vehicle components to secure and protect the wire as much as possible.

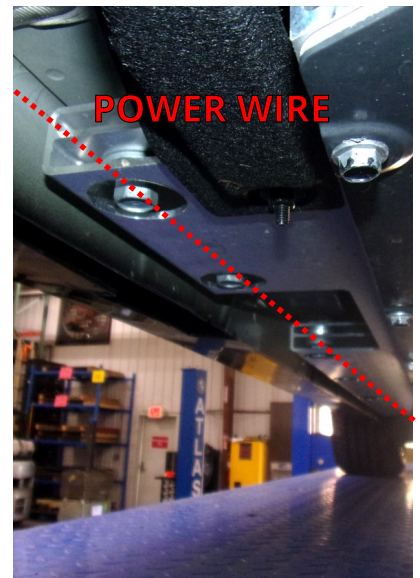
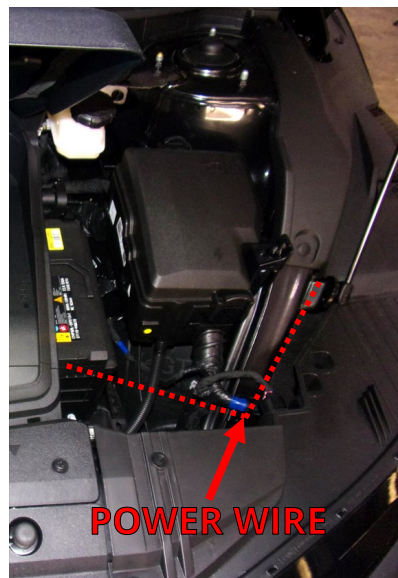



## INSTALL PASSIVE WIRING KIT CONTINUED



DRILL &  
3/8" BIT

31. Locate the rubber grommet underneath the rear of the vehicle on the driver side and remove it. Use a 3/8" drill bit and drill a hole through the center of the grommet. Feed the power wire through the grommet from outside to the inside of the vehicle. Retrieve the 4-way plug with wire. Pass the grommet over the wires so the plug will be on the outside of the vehicle. Thread the end of the wires into the hole and replace the grommet.

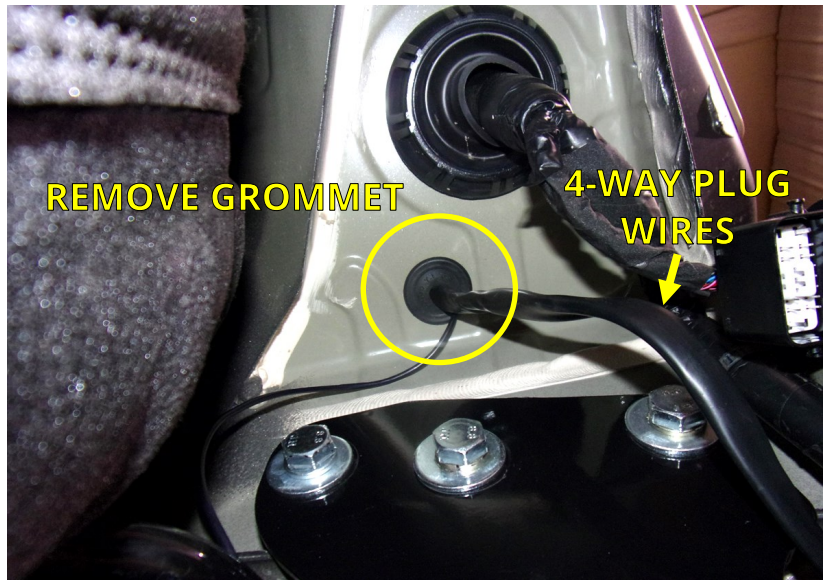

STRIPPER/  
CRIMPING  
TOOL

32. Inside the vehicle, trim the control module power wire to remove excess length. Use the included blue butt connector to crimp the power wire to the control module power wire.

**NOTICE (OPTIONAL):** The butt connector is a heat shrink connector. Apply heat to waterproof the connector after crimping.

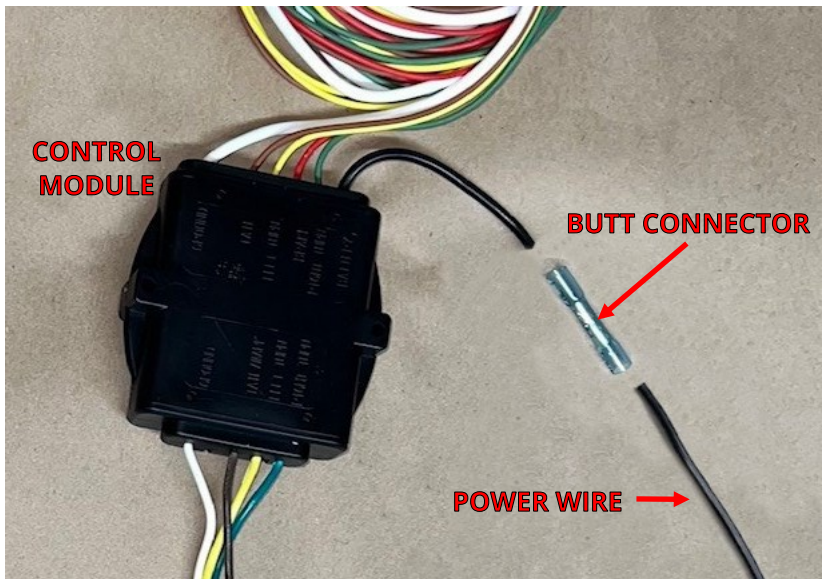

10mm  
SOCKET



STRIPPER/  
CRIMPING  
TOOL

33. Behind the driver side panel in the cargo area, locate the ground screw shown in the image. Trim white ground wire so it will reach stud without excess wire. Crimp supplied fork terminal to the ground wire with a crimping tool. Use a socket to loosen the ground screw. Secure the fork terminal to ground screw.

**NOTICE:** Loosen ground stud just enough to install fork terminal, so vehicle wiring does not lose ground.



## INSTALL PASSIVE WIRING KIT CONTINUED



STRIPPER/  
CRIMPING  
TOOL

34. Locate the tail of the 4-way connector wire and the output side wires of the control module. Attach each similar color wire to each other using a red butt connector and crimping tool.

**NOTICE (OPTIONAL):** The butt connectors are heat shrink connectors. Apply heat to waterproof the connectors after crimping.

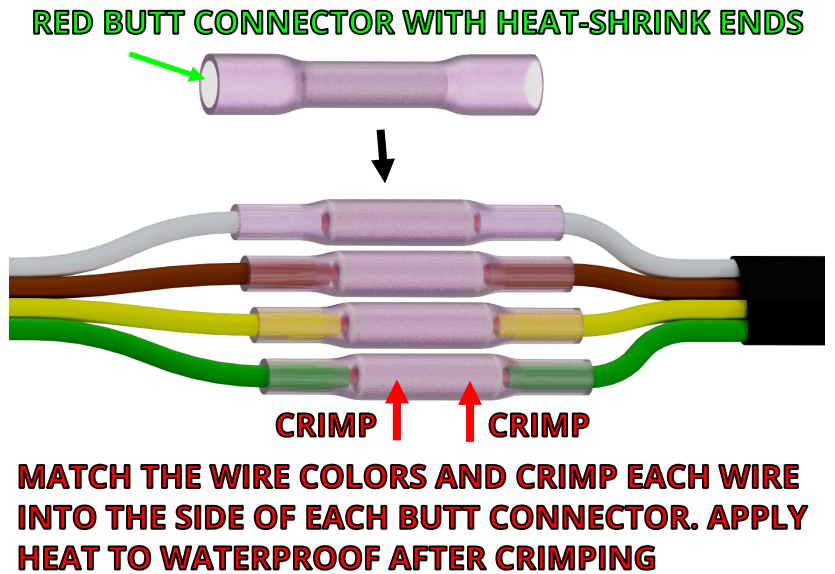

35. Secure harness to Stealth hitch frame with cable ties. Maintain an 18" loop from the cable tie to the 4-way plug. Add the magnetic cable holder and secure to the harness close to the 4-way plug, with a cable tie.

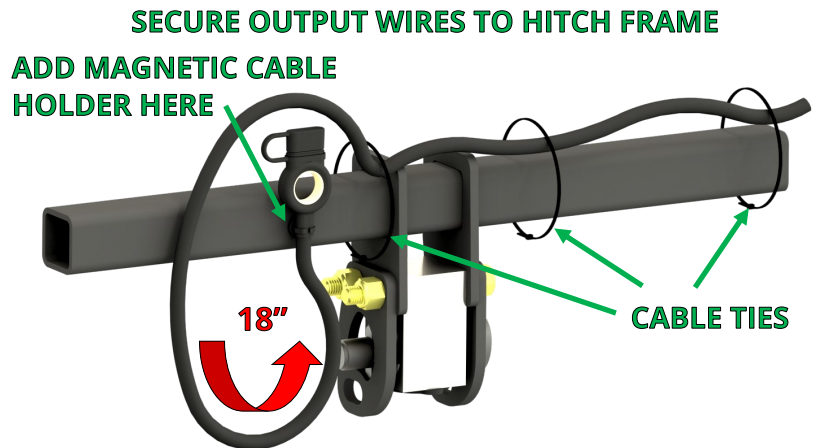

PLIERS



MULTIMETER

36. The wires on the input side of the module need to be attached to the vehicle wiring. In the driver side of cargo area, locate the indicated part of the vehicle wiring harness. Use clamp-on connectors to connect the brown and yellow input wires to wires behind taillight. (As shown in reference table on the next page.)

**NOTE:** Vehicles may have different wire colors than those shown. Verify circuits (wire colors) with multimeter.

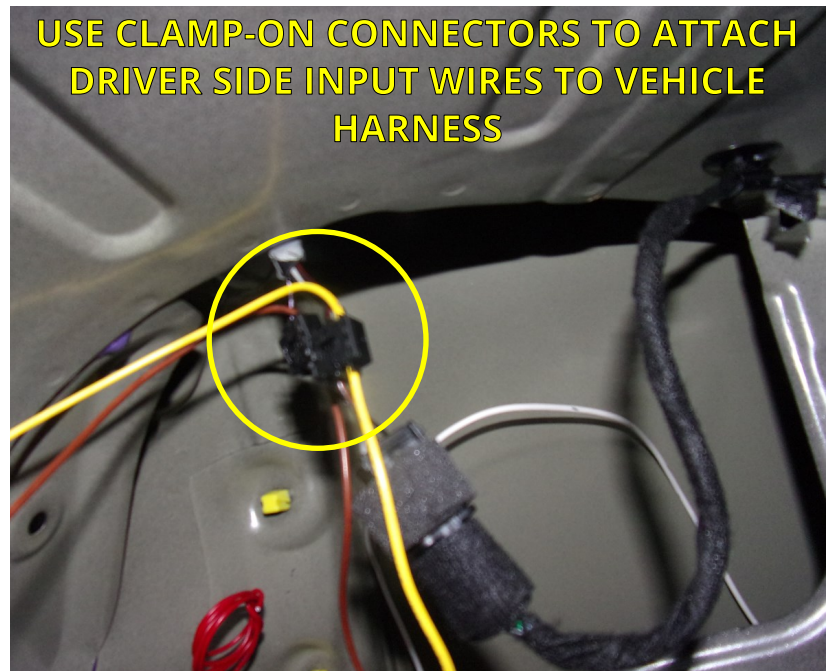



## INSTALL PASSIVE WIRING KIT CONTINUED



MULTIMETER











PLIERS

37. Dislodge the passenger side panel in the cargo compartment. Using an existing vehicle wire harness as a guide, route the green input wire to the passenger side of the vehicle. Locate the indicated part of the wiring harness. Remove the tape to gain access to the taillight wires. Use a clamp-on connector to connect the green wire to the right turn signal wire behind the taillight. (As shown in reference table below.)



### CLAMP-ON CONNECTOR COLOR REFERENCE TABLE

SIGNAL INPUT WIRES			POWER & GROUND WIRES		
FUNCTION	HARNESS	VEHICLE			
LEFT TURN	 YELLOW	 BLACK/RED	12V+ (POWER)	 BLACK	BATTERY (+)
RIGHT TURN	 GREEN	 BLACK/RED	GROUND	 WHITE	GROUND SCREW
MARKER	 BROWN	 BLACK/PINK	<b>NOTICE: Do not connect the red brake wire. This vehicle does not utilize a separate brake circuit. The brake signal is sent down the left and right turn circuits simultaneously.</b>		
BRAKE	 RED	NOT USED			

**NOTE: If two colors are listed, the first color is the dominant color.**



MULTIMETER



SILICONE

38. Reinstall the 20 Amp fuse in the harness fuse holder.

39. Test the 4-way plug using a multimeter or connect the plug to a trailer and verify that the lights and brakes work correctly.

**NOTE: Taillights will need to be temporarily plugged in during testing.**

40. Secure all wires and wiring components. Use the remaining cable ties to secure wiring so that it is not loose and will not interfere with replacement of the fascia. Wiring should not be visible once the vehicle is reassembled. Use silicone to waterproof the grommet.



IF INSTALLING A PASSIVE TOW KIT, SKIP TO STEP 51.  
IF INSTALLING AN ACTIVE TOW KIT, CONTINUE TO STEP 41.

## INSTALL ACTIVE WIRING KIT



PHILLIPS HEAD  
SCREWDRIVER



PLASTIC  
PRY TOOLS

41. Use a screwdriver to remove (3) screws securing the driver side trunk trim panel. Use a plastic pry tool to dislodge the trim panel.

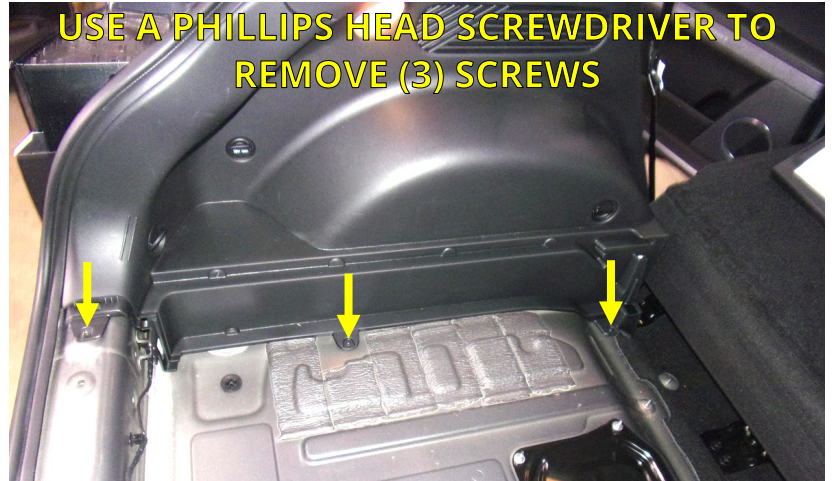

42. Dislodge the driver side panel. Behind the panel unplug the (2) connectors attached to the light and 12V outlet.

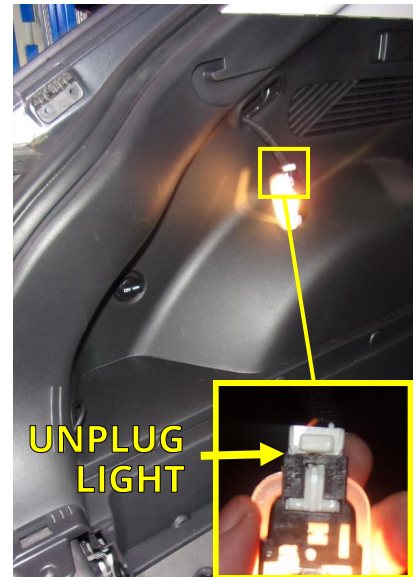

43. Locate the 6-pin connector which is taped to the vehicle wiring harness behind the driver side panel. Carefully unwrap and remove the tape from the connector.

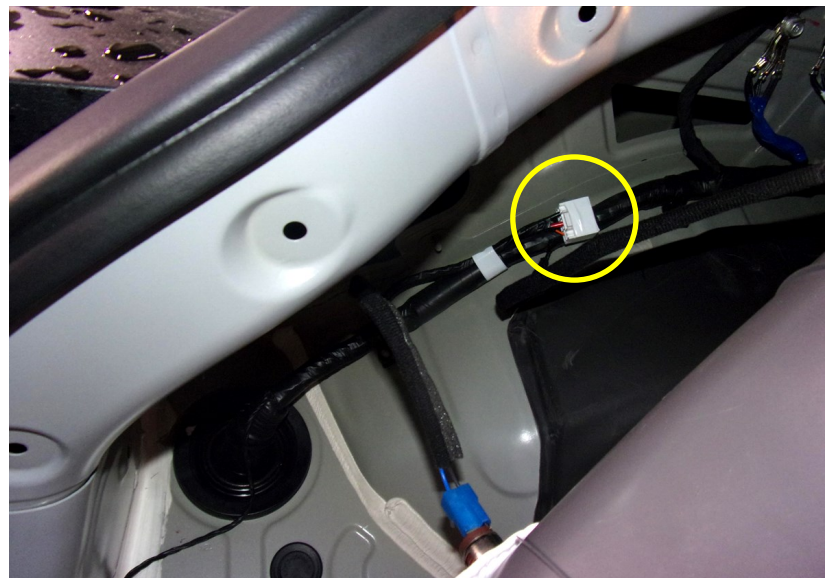



## INSTALL **ACTIVE** WIRING KIT CONTINUED

44. Behind the trunk panel on the driver side, locate and remove the indicated grommet. Discard the grommet.



45. Inside the wiring harness kit, locate the output harness. From under the vehicle, feed the small 6-pin connector up through the hole where the grommet was removed. Seat the rubber grommet into the hole.

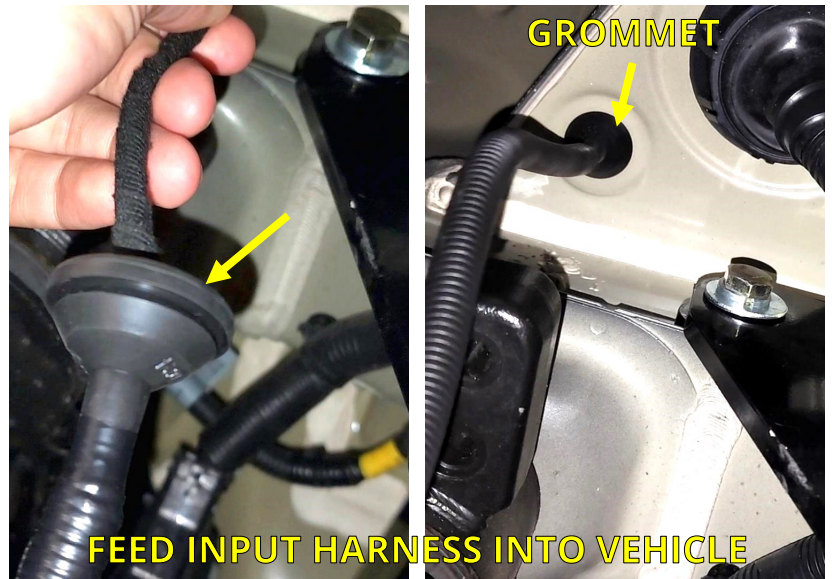

46. Secure harness to Stealth hitch frame with cable ties. Maintain an 18" loop from the cable tie to the 4-way plug. Add the magnetic cable holder and secure to the harness close to the 4-way plug, with a cable tie.

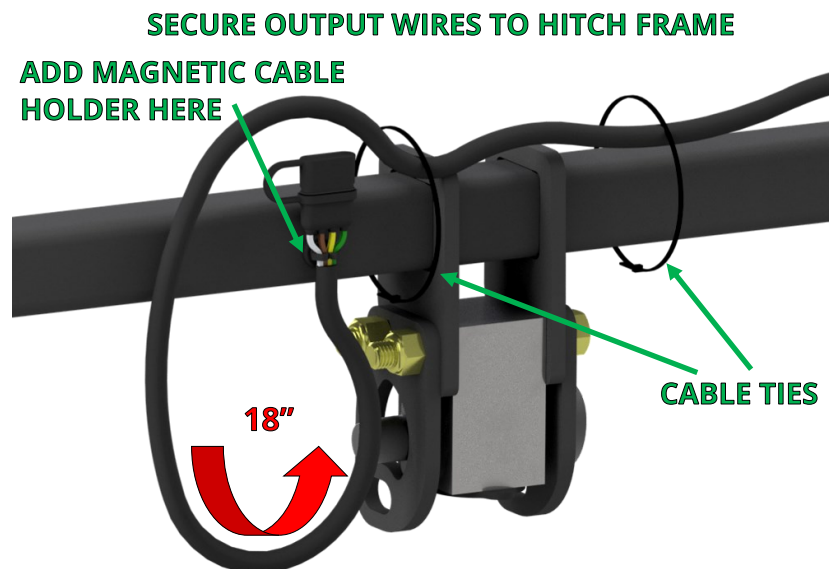

## INSTALL **ACTIVE** WIRING KIT CONTINUED

47. Inside the wiring harness kit, locate the input harness with fuse. Temporarily remove the fuse from the fuse holder. Plug the input harness 6-pin male plug into the female plug which was taped behind the panel. The two plugs should lock together.

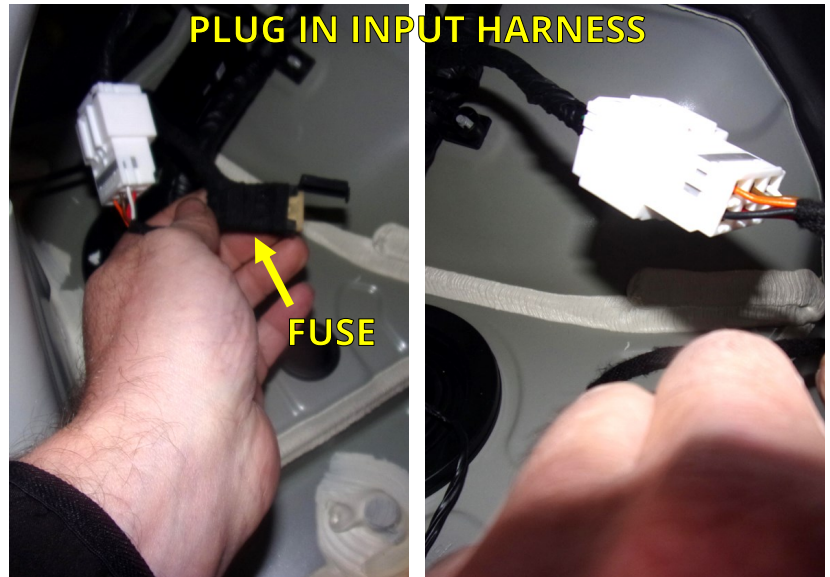

48. Inside the wiring harness kit, locate the control module. Plug the 7-pin input harness connector and 6-pin output harness connector into the control module as shown. Press each plug into place until it locks in. Replace the fuse in the fuse holder.

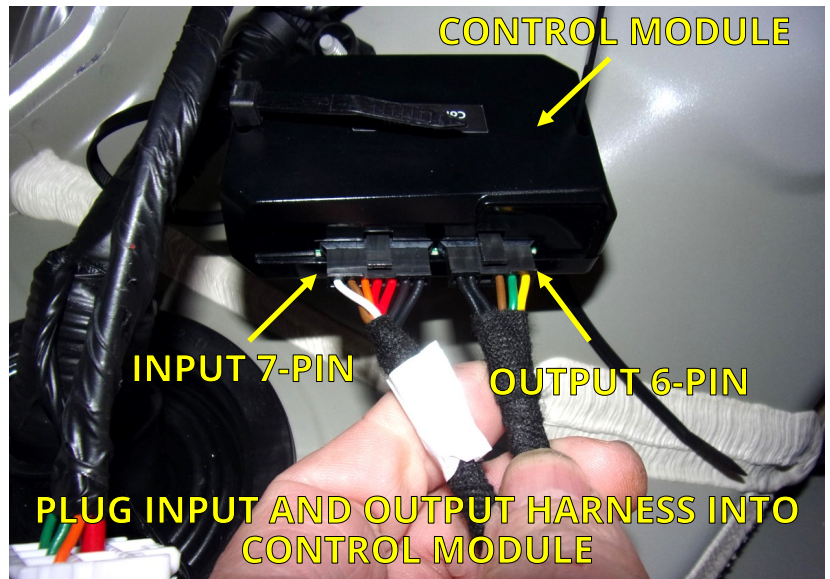

49. Use the adhesive foam strips to attach the control module to a flat area of metal inside the panel. Secure all loose wires with cable ties.





## INSTALL **ACTIVE** WIRING KIT CONTINUED



MULTIMETER

50. Test the 4-way plug using a multimeter or connect the plug to a trailer and verify that the lights and brakes work correctly. Secure all wires and wiring components. Use the remaining cable ties to secure wiring. Wiring should not be visible once the vehicle is reassembled.

## CUT ACCESS TO LATCH BLOCK



DREMEL TOOL



FILE

51. Use a Dremel tool to cut out the gravel guard, as shown. Use file to smooth out the cut.

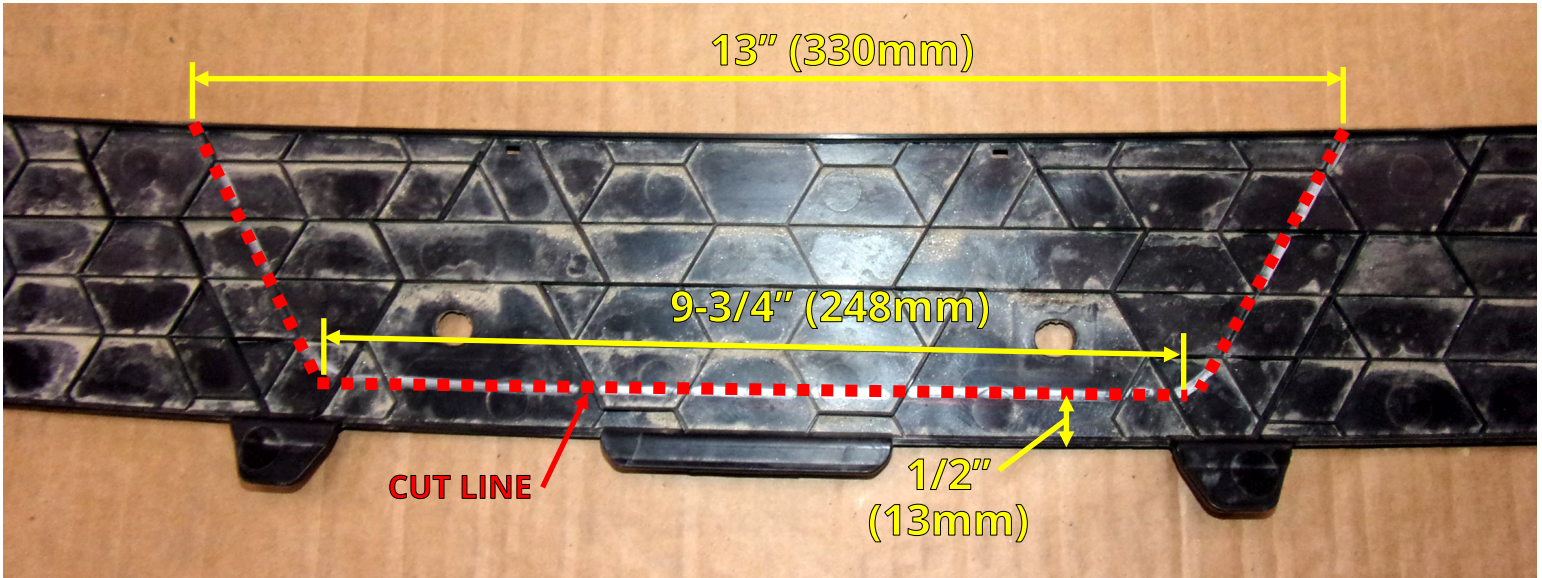

DREMEL TOOL



FILE

52. Use a Dremel tool to cut off (2) tabs in the bottom middle of the fascia, as shown. Use file to smooth out the cut.



## REINSTALL VEHICLE COMPONENTS

53. Reattach and secure the fascia, wheel well trim, and other vehicle components in reverse order. Refer to Steps 1-15.

**NOTICE:** Remember to plug in the sensor plugs in Steps 12-14 before reinstalling the fascia.



## FINAL VEHICLE EXAMINATION

54. Examine the body panels to ensure that they are in a pre-installation condition. Test the electronic functions of the vehicle. Correct any inconsistencies.
55. Ensure that hitch components work properly.
  - **Verify that the lock works correctly.** Push in the safety lock on the latch block then unlock with key. The lock should slide back out with the key when unlocked.
  - **Verify that each accessory can be installed correctly.** Use the following steps to install and remove each accessory that will be used with the hitch. (*Rack Receiver and Ball Mount if purchased.*)
    1. Prepare latching mechanism. Turn handle clockwise if needed.
    2. Firmly insert "post" of accessory into latch block until handle releases indicating that the accessory is latched.
    3. Push in the safety locking pin until it fully engages. The locking pin prevents the handle from turning when pushed in, and confirms that the block is securely latched onto the accessory. The safety locking pin will not depress if the accessory is not fully latched.
    4. Use key to release safety locking pin.
    5. While holding on to the accessory, rotate handle clockwise to release and remove the accessory.
  - **Verify that no part of the accessories come into contact with the body of the vehicle.**

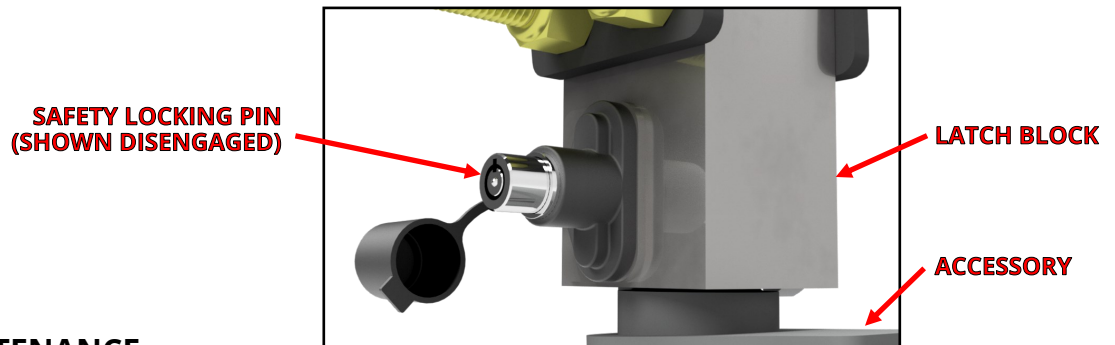

## PRODUCT USE AND MAINTENANCE

**NOTICE: If the hitch is being installed by a professional, the installer is responsible for training the end user in the use and maintenance of the product.**

- **Accessory installation procedure:**
  1. Prepare latching mechanism. Turn handle clockwise if needed.
  2. Firmly insert "post" of accessory into latch block until handle spins counter-clockwise indicating that the accessory is latched.
  3. Always depress the safety locking pin and check that it has fully engaged.
- **Never use any accessory with the safety lock disengaged.** Until the safety locking pin is engaged, the handle is able to turn. A fully engaged safety locking pin is confirmation that the accessory is properly latched into the latch block.
- **Never use the rack receiver for towing.** The rack receiver accessory is only to be used with payload carrying products, such as bike racks or luggage racks.
- **Before each use, give the post of the accessory a light coating of lithium based grease.**
- **Before each use, inspect the hitch to ensure that all bolted connections are secure and that no cracks or damage are present.** Do not tow with the hitch if cracks or damage outside of normal wear is found.
- **Remove the Stealth accessories from the latch block after each use.** Do not leave accessories plugged in for extended periods of time.

SHR62003\_(pn 2120-62003-2) 01 17 2024