



HITCH INSTALLATION INSTRUCTIONS

MAKE: YEARS: PORSCHE 2014 - 2024
MODEL/TRIM: Macan & Macan S
 2022 - 2024 Macan GTS
 2014 - 2022 Macan Turbo
 2024 Macan T

www.stealthhitches.com 833-694-4824

RACK RECEIVER KIT#: **SHR35004**

COMPATIBLE WITH TOW KITS: **SHT25030**



2" RACK RECEIVER MAXIMUM PAYLOAD: 600 LBS
MAXIMUM TOW RATING: 6000 LBS
MAXIMUM TONGUE WEIGHT: 600 LBS

UNDER VEHICLE TRIMMING:

HEAT SHIELD: **NO**
 FASCIA: **YES**
 GRAVEL GUARD TRIMMING: **NO**



READ ALL INSTRUCTION WARNINGS AND LABELS



NO WELDING, METAL DRILLING OR VISIBLE TRIMMING REQUIRED

PARTS SUPPLIED WITH RACK RECEIVER KIT:

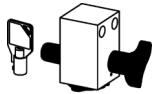

LATCH BLOCK & KEYS



(2) BOLTS
5/8"-11 x 5"



(2) 5/8"
NYLOCK NUTS



2" RACK RECEIVER

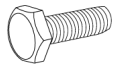

(8) 1/2" - 13 x
1-1/2" BOLTS



(8) 1/2" LOCK
WASHERS



(8) 1/2" NUTS

ADDITIONAL PARTS FOR TOW KIT:



BALL MOUNT
5" RISE, SHORT



CHAIN HOOKS



2" BALL

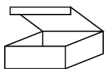

PASSIVE WIRING KIT
BOX

TOOLS REQUIRED:



3/4" & 15/16" OPEN
END WRENCH



10mm, 16mm,
3/4",
& 15/16" SOCKETS



RATCHET

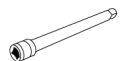

SOCKET
EXTENSION



TORQUE
WRENCH



T25 & T30 TORX



FLASHLIGHT



PLASTIC
PRY TOOLS



SAFETY GLASSES



DREMEL TOOL



FILE



DRILL &
3/8" BIT

ADDITIONAL TOOLS FOR TOW KIT:



STRIPPER/
CRIMPING
TOOL



MULTIMETER



PHILLIPS HEAD
SCREWDRIVER



13mm
SOCKET



PLIERS



SILICONE

RACK RECEIVER INSTALLATION: USE STEPS 1-17 & 31-34
PASSIVE TOW KIT INSTALLATION: USE STEPS 1-34

<THESE INSTRUCTIONS MUST BE GIVEN TO THE END USER>

NOTICE: Installation of Stealth products may or may not require the addition of a wiring harness to the vehicle.

- The Rack Receiver only product does not require adding a wiring harness.
- The Rack Receiver plus Tow Kit requires the addition of a "Passive" wiring harness to the vehicle. The passive harness "reads" the output of the vehicle's lights and translates the signals to the trailer without being connected to the vehicle computer.

INSTALLATION NOTE: In most instances, these instructions will only outline disassembly of vehicle components. Re-installation of components will require the installer to retain vehicle hardware and work through disassembly instructions in reverse order. When installation is complete, double check that all vehicle components have been replaced and are secured.

IMPORTANT SAFETY NOTICE FOR STEALTH HITCH INSTALLERS AND CUSTOMERS.

Read all installation and operating instructions along with all labels before installing or using this product. Do not perform any installation or towing procedures without fully understanding the correct tools and actions for all steps. Call for support if needed.

⚠ WARNING Failure to comply with the safety information in these instructions could result in serious injury or death.

- ⚠ Do not modify this product in any manner. Doing so could alter its integrity and lead to a loss of attachment between the trailer and the tow vehicle.
- ⚠ Adding Stealth hitch components to the chassis of any vehicle can be hazardous. There is potential for unexpected combustion of fuel, electric shock, burns, shifting or falling of unstable vehicle, damage to vehicle, injury from tool usage and many other hazards. This installation must be completed by someone who is aware of the hazards involved. This person must be knowledgeable of proper safety procedures for a vehicle modification of this nature, and for usage of the equipment required to perform the installation.
- ⚠ Without proper knowledge, towing can be a dangerous activity. Understand all the risks involved with towing before proceeding. For information on towing safety, see "**The Trailer Handbook: A Guide to Understanding Trailer and Towing Safety**" from the National Association of Trailer Manufacturers, www.NATM.com and your trailer and tow vehicle manufacturer's owner's manual.
- ⚠ Do not exceed tow or tongue rating of coupler, tow or tongue rating of hitch, or tow or weight ratings of tow vehicle or trailer. See vehicle and trailer manufacturer information for ratings. Exceeding these ratings may cause damage to towing components or loss of attachment between the trailer and vehicle.
- ⚠ While installation is being performed, check for signs of damage or excessive corrosion. Do not install hitch components over vehicle parts that are broken or have compromised structural integrity.
- ⚠ This product was designed to fit vehicles in their original, "as manufactured" condition. Compatibility with vehicles having replacement parts, or other modifications is not guaranteed. Inspect vehicle for modifications before installation of this product.
- ⚠ Some accessories, like the rack receiver, are not rated for towing. Do not use any accessories without proper knowledge of their use.
- ⚠ A visual inspection of the hitch should be performed before each use. Regularly check that all connections are secure, including those that secure the hitch to the vehicle. Check for cracks or damage to the hitch. Do not use the hitch if cracks or damage outside of normal wear is found. Using a hitch that has unsecure connections and/or cracks or damage could result in damage to the tow vehicle, trailer, towing components and loss of attachment between the tow vehicle and trailer.
- ⚠ Stealth hitches are not compatible with any weight distribution or sway control products. Adding additional products to the trailer or chassis which modifies the function of the Stealth hitch may cause hitch failure.

NOTICE: Installation of hitch requires removal of vehicle parts and interaction with vehicular electronics. Before installation, check the condition of body panels and note any locations where panels are not flush. Check the electronic functions of the vehicle, such as: headlights, taillights, turn signals, cameras, backup sensors, Parking Distance Controller (PDC), foot activated cargo access, etc. It is the responsibility of the installer to restore the fit and function of the vehicle.

GAIN ACCESS TO MOUNTING AREA

1. Lift up to remove cargo area floor panel.

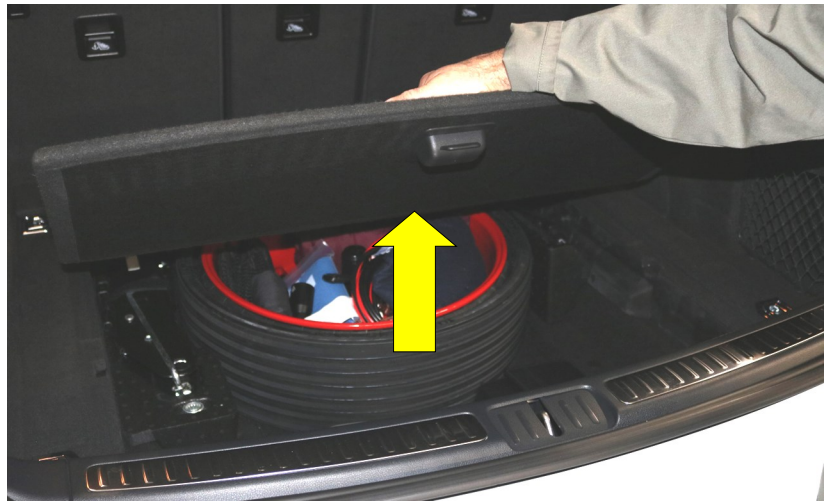

2. Remove the access panel covers from both driver and passenger side.

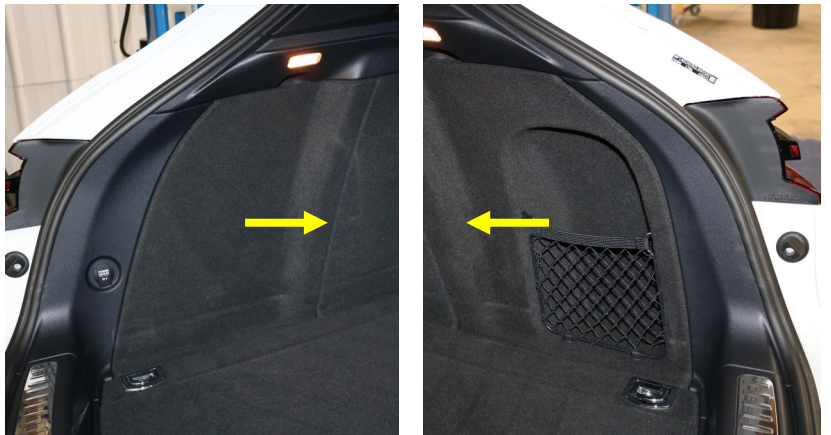

T30 TORX

3. Remove spare tire, jack, and tool holder, refer to owner's manual if needed. In the corners of the cargo area, locate and remove (4) cargo anchors. Each cargo anchor has (2) screws. On each side of the cargo area, remove the large plastic rails.



GAIN ACCESS TO MOUNTING AREA CONTINUED



10mm
SOCKET

4. In the rear of the vehicle cargo area loosen (2) plastic nuts securing the fascia. Carefully lift up and remove the threshold behind the hatch.

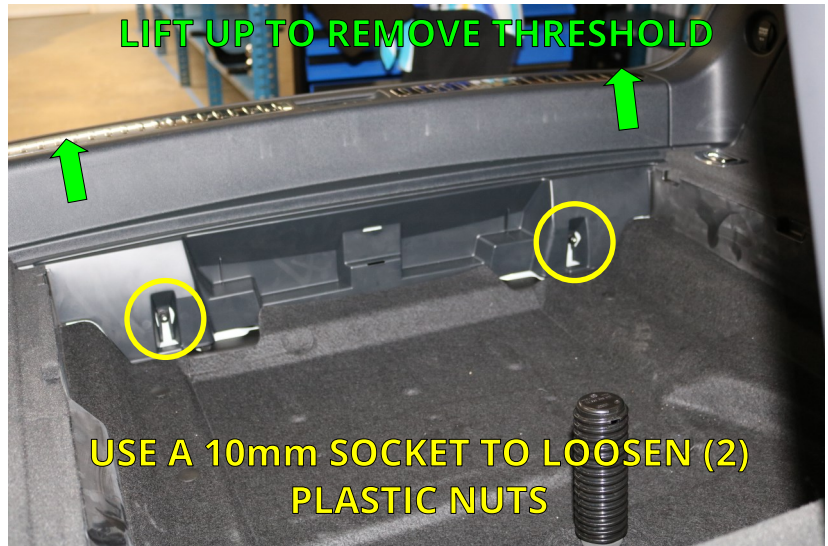

T30 TORX



PLASTIC
PRY TOOLS

5. With the rear hatch open, locate and remove (2) screws from the rubber stops on both sides of the hatch frame, using a Torx (yellow arrows).
6. Remove the plastic taillight covers using a plastic pry tool. Insert plastic pry tool and pry outward as shown.



T25 TORX

7. Under each taillight cover is a screw which is holding the fascia. Remove this screw using a Torx. Repeat on other side of vehicle.



GAIN ACCESS TO MOUNTING AREA CONTINUED



T25 TORX

8. Inside the rear wheel well, behind the tire, locate the (4) screws which are holding the wheel well liner (yellow arrows). Remove these screws and move the liner back toward the tire. Behind the liner locate and remove (3) additional screws (green arrows).

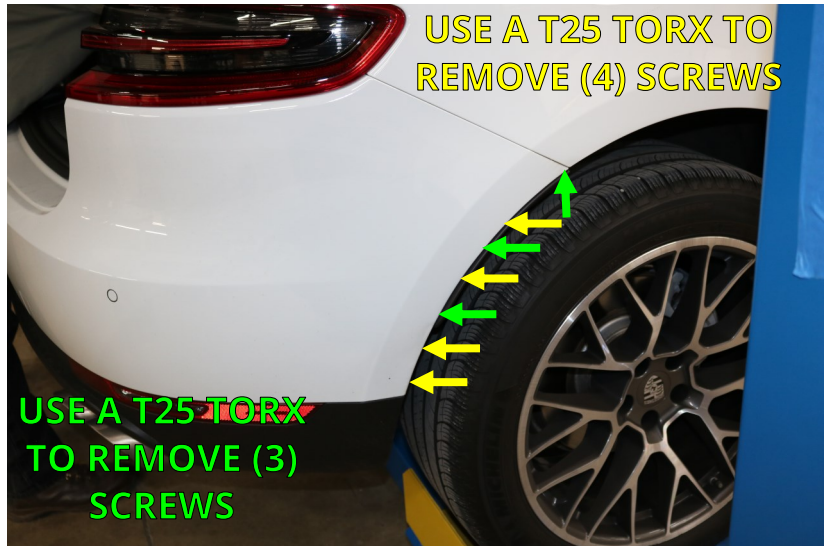

T25 TORX

9. **2014-2021 vehicles:** Locate (1) screw holding the fascia underneath the vehicle behind rear wheel. Remove this screw. Repeat Steps 8-9 on other side of vehicle.
- **2022+ vehicles:** Locate (1) screw underneath the vehicle on the bottom edge of the fascia. Remove this screw. Repeat Steps 8-9 on other side of vehicle.

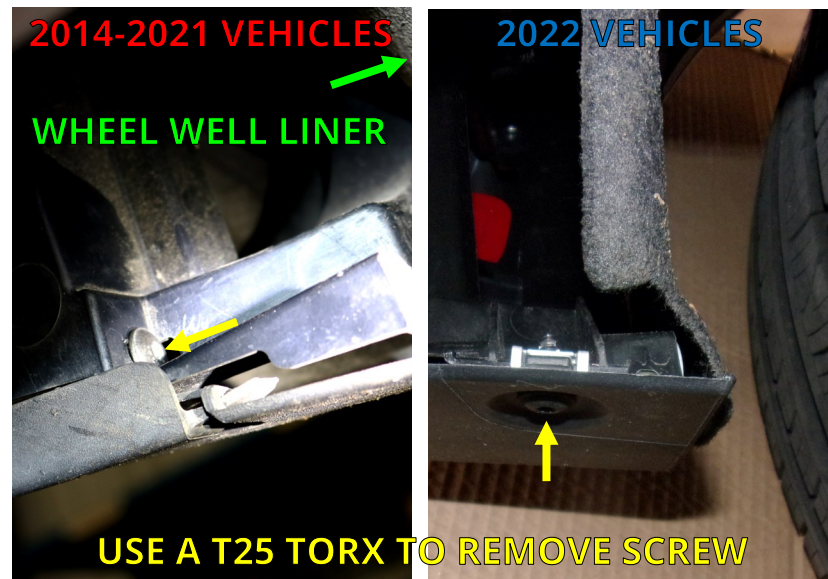

T25 TORX

10. Underneath the vehicle remove (2) screws from the rear of the fascia, as shown.



GAIN ACCESS TO MOUNTING AREA CONTINUED



PLASTIC
PRY TOOLS

11. The rear fascia is clipped to the vehicle body above and behind the wheel wells. Pull outward on the top front of the rear fascia to expose a clip in the seam. With a plastic pry tool, push down on the exposed clip to disconnect. Continue to pull outward on the fascia and disconnect clips, until all the clips are released. Repeat on other side of vehicle.



12. The fascia will not be completely disconnected from the vehicle, a wiring harness attached to the fascia must remain attached. Before removing the rear fascia, set up a stand or place a pad down near the rear passenger side of the vehicle. Carefully pull the fascia away from the vehicle. Some vehicle models may have a hydraulic hose on the driver side of the vehicle. Disconnect the hose by unclipping. Move the fascia away from the vehicle and place on the stand or pad prepared earlier.



NOTICE: Carefully remove the fascia and place on a blanket or pad.

NOTICE: If the electrical harness becomes disconnected the vehicle will need reprogramming at a Porsche Dealership.

NOTICE: Do not allow any hydraulic oil to come into contact with the vehicle paint.



16mm
SOCKET

13. Inside the cargo area locate (2) bolts securing a bracket on each side of the vehicle. These bolts also secure the factory reinforcement beam. Remove bolts using a socket. Save the bolts for later reinstallation.

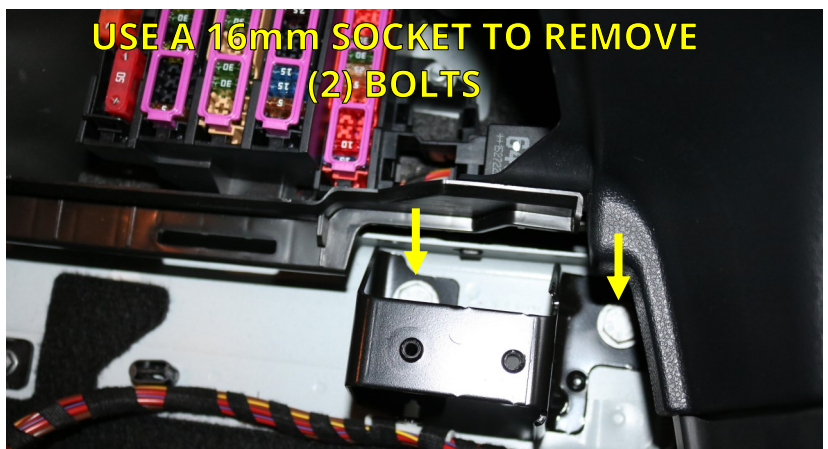

GAIN ACCESS TO MOUNTING AREA CONTINUED

14. With the (4) bolts securing the factory reinforcement beam removed, slide the beam to the rear to remove. Discard the factory reinforcement beam.



INSTALL STEALTH HITCH FRAME



3/4"
SOCKET



3/4"
WRENCH

15. Retrieve the side plates, hitch frame, 1/2" bolts, lock washers, and nuts. Use a 3/4" socket and wrench to attach the side plates to the hitch frame, as shown in the image. Before tightening, align the side plates so that the tops are parallel to the top of the hitch frame. Torque the bolts to 110 ft.-lbs.

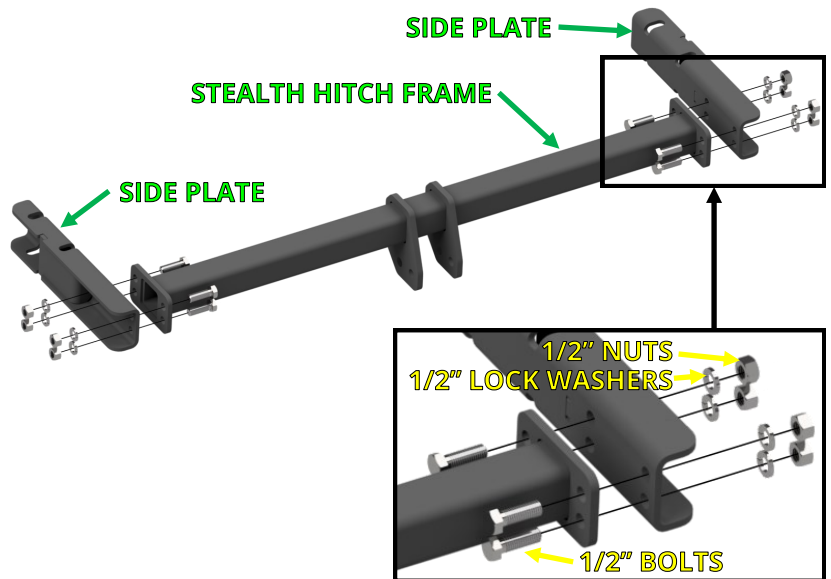

16mm
SOCKET



TORQUE
WRENCH

16. Slide the Stealth hitch frame into the vehicle chassis channels where the factory reinforcement beam was removed. Align the (4) vehicle and hitch frame holes inside the cargo area of the vehicle. Center the hitch frame assembly in the middle of the vehicle. Secure Stealth hitch frame and brackets with (4) saved factory bolts. Torque bolts to 45 ft.-lbs.

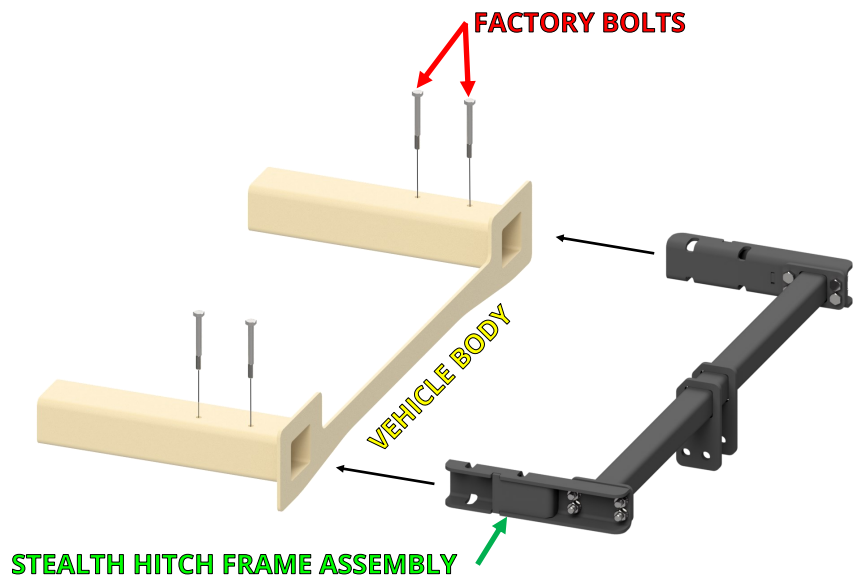

MOUNT LATCH BLOCK



15/16"
SOCKET



15/16" OPEN
END WRENCH



TORQUE
WRENCH

17. Installation of the latch block varies depending on which kit you are installing.

- **Rack Receiver Kit:** Install the latch block with (2) 5/8"-11 x 5" bolts and (2) 5/8" nylock nuts. Tighten each bolt to 150 ft.-lbs.
- **Tow Kit:** Retrieve C-bracket from wiring harness kit box. Install the latch block, (2) chain hooks, and C-bracket with (2) 5/8"-11 x 5" bolts and (2) 5/8" nylock nuts. Tighten each bolt to 150 ft.-lbs.

NOTICE: Keys are packaged within the latch block, remove keys and store in safe location.

RACK RECEIVER KIT INSTALL



TOW KIT INSTALL

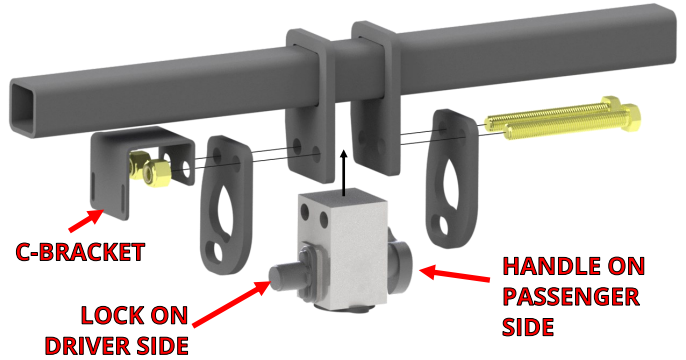

IF INSTALLING A RACK RECEIVER KIT, SKIP TO STEP 31.
IF INSTALLING A TOW KIT, CONTINUE TO STEP 18.

INSTALL PASSIVE WIRING KIT

PASSIVE WIRING KIT BOX

#	DESCRIPTION	QTY
1	7-WAY UNIVERSAL WIRING HARNESS	1
	<ul style="list-style-type: none"> FUSE HOLDER & FUSE CONTROL MODULE 	
2	ADHESIVE FOAM STRIP	2
3	5/8" LONG PHILLIPS SCREWS	6
4	#10 LOCK NUT	6
5	FORK TERMINAL	1
6	CLAMP-ON CONNECTORS	5
7	CABLE TIE - 8"	4
8	CABLE TIE - 14"	3
9	C-BRACKET	1
10	MOUNTING BRACKET	1
11	7-POLE HOUSING	1
12	7-POLE TO 4-POLE ADAPTER	1



18. Locate the wiring kit box. Review the contents of the box against the list above to check for missing components. The passive wiring kit uses a control module to manage the functions of the trailer lighting. The module has an **"input"** side that receives power from the vehicle's battery and signals from the vehicle's taillights. The **"output"** side of the module delivers this information to the 7-way plug. The control module is connected to the vehicle's battery and taillight wiring as outlined in the next steps.

NOTICE: Do not allow electrical system to become disconnected from power or ground. Doing so may interrupt electrical systems.

PASSIVE HARNESS DIAGRAM

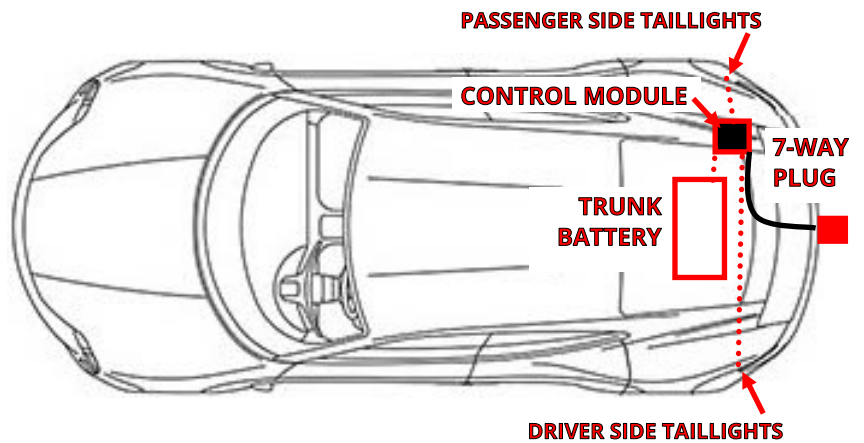
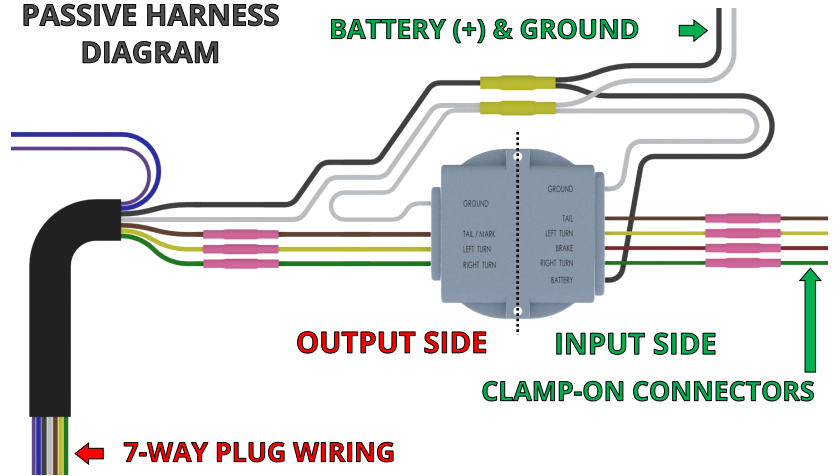

INSTALL WIRING KIT CONTINUED

19. Place control module in rear passenger side cargo area. Locate rubber grommet on rear of vehicle, behind Stealth hitch frame. Remove the grommet.

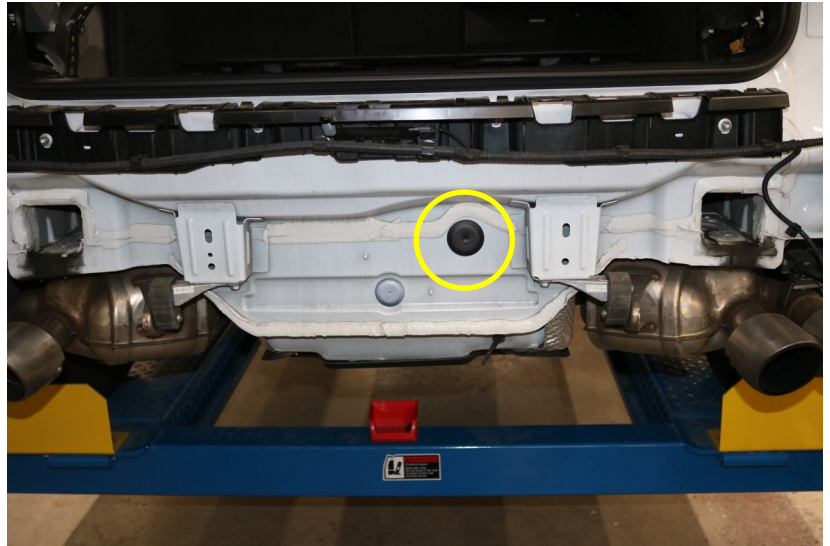

DRILL &
3/8" BIT

22. Drill a 3/8" hole in grommet. Feed the output wires from the inside to the outside of the vehicle through the hole where the grommet was. Pass the grommet over the end of the output wires.



WIRE 7-WAY PLUG



PHILLIPS HEAD
SCREWDRIVER

21. Locate 7-way housing. Use a screwdriver to loosen (2) screws. Remove 7-way round terminal block. Place the mounting bracket onto the 7-way housing as shown. Use a screwdriver to loosen the set screw at the bottom of the 7-way housing. Route output side wires of the wiring harness through the 7-way housing.

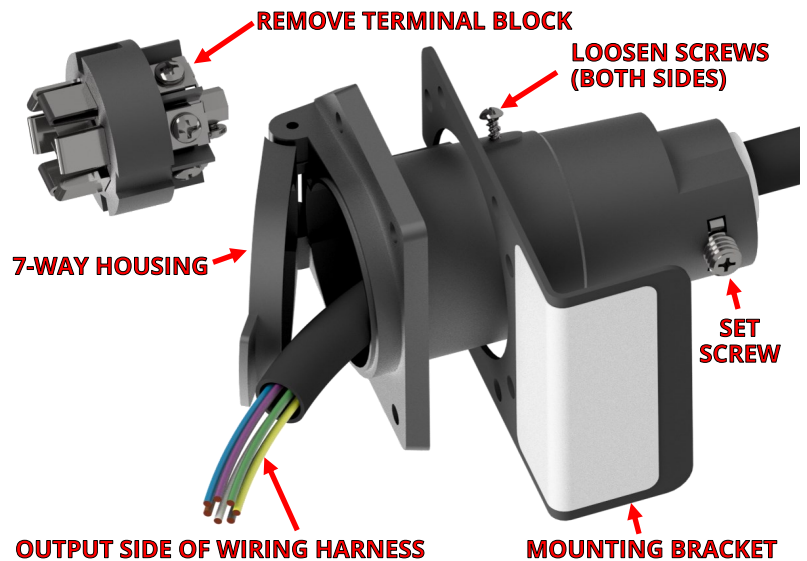

WIRE 7-WAY PLUG CONTINUED

Please follow instructions below very carefully.
Incorrect wiring of the 7-way receptacle causes the vast majority of wiring problems.



PHILLIPS HEAD
SCREWDRIVER

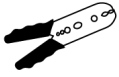

STRIPPER/
CRIMPING
TOOL

22. Locate the slot keyway.
Starting from the keyway
going **clockwise**, attach the
wires as follows:

- Blue
- Green
- Black
- Brown
- Yellow
- White
- Purple (middle)

NOTICE: Markings on the receptacle may not match the correct wire configuration. Please disregard and follow the instruction above.

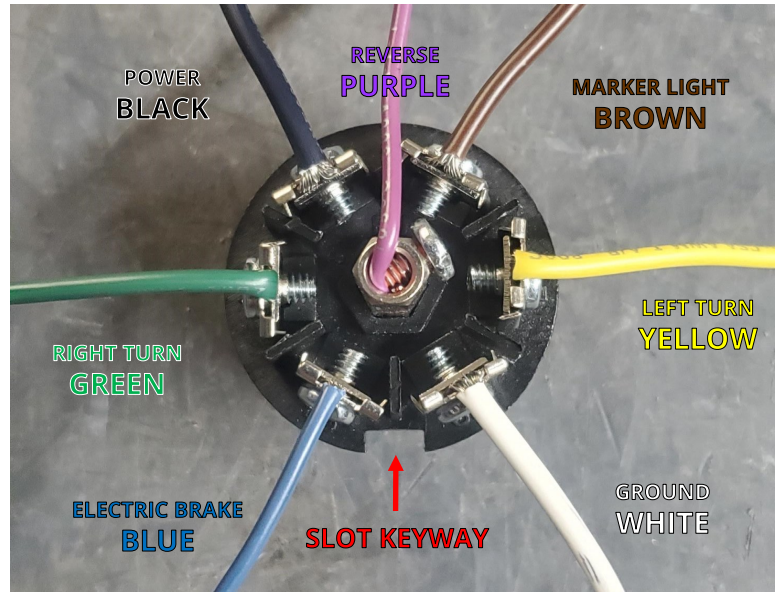

PLIERS



MULTIMETER

23. The wires on the input side of the wiring module need to be attached to the vehicle wiring. Inside the passenger side compartment, use clamp-on connectors to connect the green, brown, and red wires to wires behind taillight. (See reference table on next page.)

NOTICE: on 2022+ vehicles two brown wires may be present. Use the wires in the indicated row. The larger brown wire in the other row is a ground wire.

NOTE: Vehicles may have different wire colors than those shown. Verify circuits (wire colors) with multimeter.

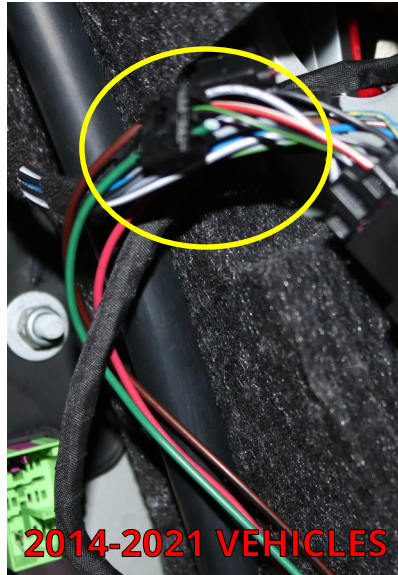

2014-2021 VEHICLES

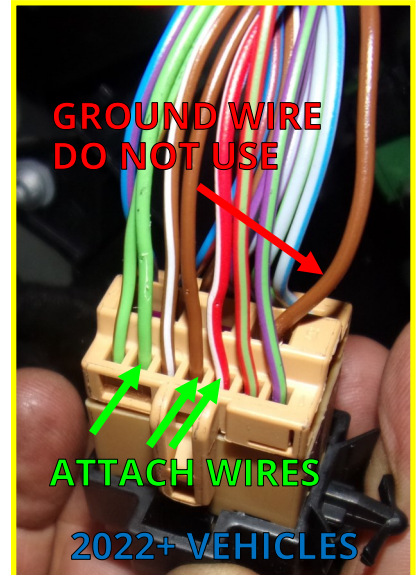

2022+ VEHICLES



PLIERS



MULTIMETER

24. Use an existing vehicle wire harness as a guide to route the yellow input wire to the driver side of the vehicle. Locate the indicated part of the vehicle wiring harness. Use a clamp-on connector to connect the yellow wire to left turn signal wire behind the taillight. (As shown in reference table on the next page.)

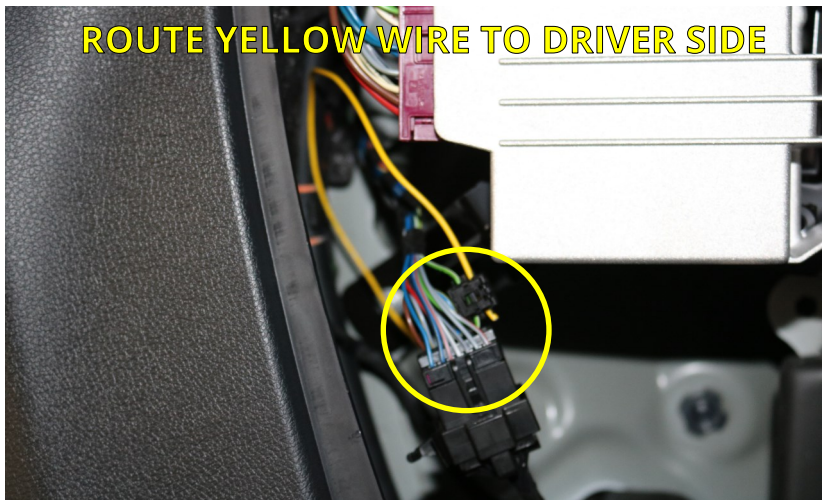

INSTALL WIRING KIT CONTINUED

CLAMP-ON CONNECTOR COLOR REFERENCE TABLE

SIGNAL INPUT WIRES				POWER & GROUND WIRES		
FUNCTION	HARNESS	MODEL YEAR	VEHICLE			
LEFT TURN	YELLOW	(2014-2021)	GREEN/WHITE	12V+ (POWER)	BLACK	BATTERY (+)
		(2022)	YELLOW			
RIGHT TURN	GREEN	(2014-2021)	BLACK/GREEN	GROUND	WHITE	GROUND STUD
		(2022)	GREEN			
MARKER	BROWN	(2014-2021)	BLACK			
		(2022)	BROWN			
BRAKE	RED	(2014-2021)	BLUE			
		(2022)	RED/WHITE			
REVERSE	PURPLE	For use with trailer reverse lights or to disable the trailer brakes when backing with surge brakes. To connect, isolate vehicle's reverse light circuit and connect the purple wire from the trailer wiring harness to vehicle reverse light circuit. Trailers rarely have reverse lights or surge brakes.				
ELECTRIC BRAKE	BLUE	Only used when a hard wired brake controller is mounted inside the vehicle and your trailer has electric brakes. See brake controller instructions for this wire.				

NOTE: If two colors are listed, the first color is the dominant color.



STRIPPER/
CRIMPING
TOOL



10mm
SOCKET

25. Locate the ground stud in the rear passenger side cargo area. Trim white ground wire so it will reach stud without excess wire. Crimp supplied fork terminal to the ground wire with a crimping tool. Loosen the ground stud and secure the terminal to the ground stud.

NOTICE: Loosen ground stud just enough to install fork terminal, so vehicle wiring does not lose ground.



STRIPPER/
CRIMPING
TOOL



13mm
SOCKET

26. Locate the fuse holder supplied in the wiring kit box. Remove the fuse from fuse holder. Crimp fuse holder lead to black power wire and connect to the positive battery terminal (+).



TEST 7-WAY HARNESS WIRING



PHILLIPS HEAD
SCREWDRIVER



MULTIMETER

27. Put the 7-way receptacle back together. While everything is still accessible, you should test the wiring to make sure everything is connected properly and in working order. **Replace the 20 Amp fuse into the fuse holder located near the battery.**

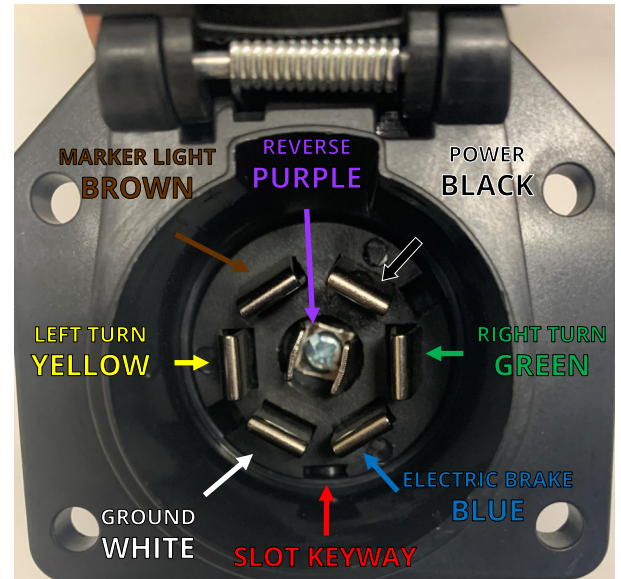

- Start by connecting the multimeter negative probe to the ground blade on the 7-way receptacle.
- Next, connect the multimeter positive probe to the power blade on the 7-way receptacle and check for 12 volts.
- Once that is confirmed, move the positive probe to the left turn blade on the 7-way receptacle and check for 12 volts when the vehicle left turn blinker is active. You should see it pulse.
- Next, move the positive probe to the right turn blade and check for 12 volts when the right turn blinker is active. You should see it pulse.
- Next, move the positive probe to the marker/taillights. With the vehicle lights on you should see 12 volts constant.
- Lastly, with the brake depressed, move the positive probe to the left turn blade where you should see 12 volts constant. Move the probe to the right turn blade where you should also see 12 volts constant.

MOUNT 7-WAY HARNESS WIRING



PHILLIPS HEAD
SCREWDRIVER



SILICONE

28. Attach the mounting bracket and 7-way housing to the Stealth hitch frame as shown. Secure harness to Stealth hitch frame with cable ties.

29. Secure all wires and wiring components. Use the remaining cable ties to secure wiring so that it is not loose and will not interfere with replacement of the fascia. Wiring should not be visible once the vehicle is reassembled. Reinstall grommet and use silicone to waterproof it.

30. Use the provided adhesive foam strips to secure the control module to an inside body panel.

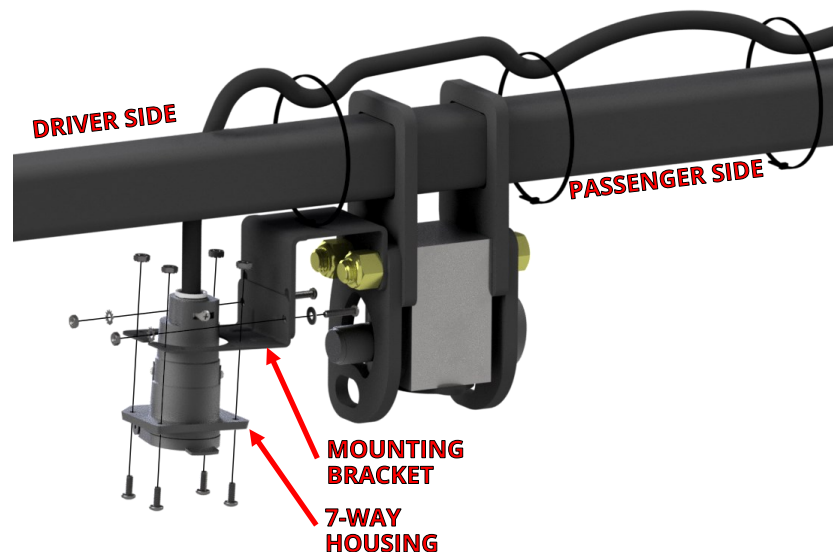

CUT ACCESS TO LATCH BLOCK



DRILL &
3/8" BIT



DREMEL TOOL



FILE

31. **2014-2021 vehicles:** Cut out the fascia with Dremel tool. As shown in the two images with yellow text. Use a file to smooth out the cut.

NOTE: The access hole necessary is different for the rack receiver and tow kits. Follow correct template.



- **2022+ vehicles:** Cut out the fascia with Dremel tool. As shown in the two images with green text. Use a file to smooth out the cut.

NOTE: The access hole necessary is different for the rack receiver and tow kits. Follow correct template.

NOTE: Images for 2022+ models may differ slightly from vehicle components.

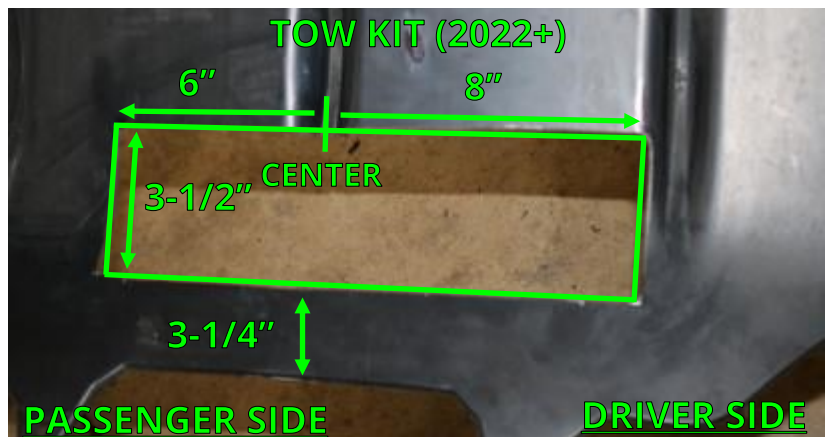
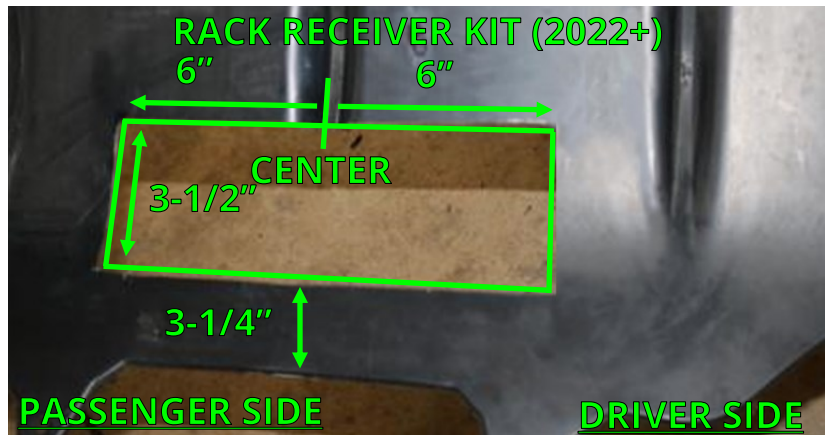

REINSTALL VEHICLE COMPONENTS

32. Reattach and secure the fascia and other vehicle components in reverse order. Refer to Steps 1-12.



33. **2014-2021 vehicles:** View of the finished tow kit installation.



- **2022+ vehicles:** View of the finished rack kit installation.



FINAL VEHICLE EXAMINATION

33. Examine the body panels to ensure that they are in a pre-installation condition. Test the electronic functions of the vehicle. Correct any inconsistencies.
34. Ensure that hitch components work properly.
 - **Verify that the lock works correctly.** Push in the safety lock on the latch block then unlock with key. The lock should slide back out with the key when unlocked.
 - **Verify that each accessory can be installed correctly.** Use the following steps to install and remove each accessory that will be used with the hitch. (*Rack Receiver and Ball Mount if purchased.*)
 1. Prepare latching mechanism. Turn handle clockwise if needed.
 2. Firmly insert "post" of accessory into latch block until handle releases indicating that the accessory is latched.
 3. Push in the safety locking pin until it fully engages. The locking pin prevents the handle from turning when pushed in, and confirms that the block is securely latched onto the accessory. The safety locking pin will not depress if the accessory is not fully latched.
 4. Use key to release safety locking pin.
 5. While holding on to the accessory, rotate handle clockwise to release and remove the accessory.
 - **Verify that no part of the accessories come into contact with the body of the vehicle.**

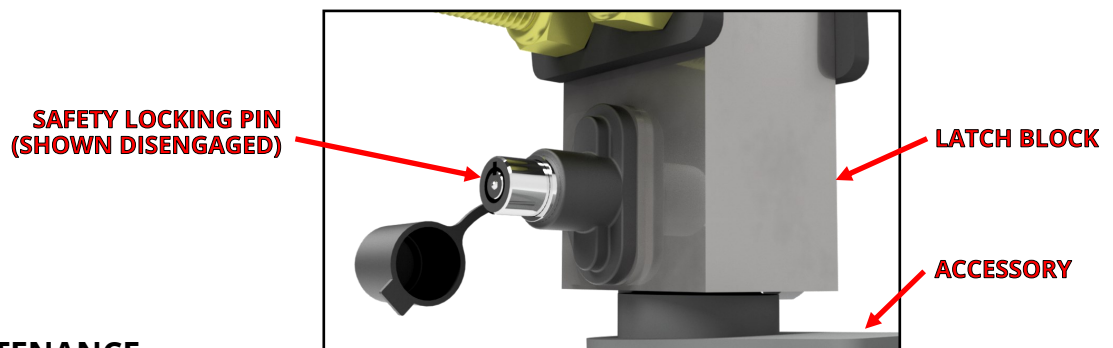

PRODUCT USE AND MAINTENANCE

NOTICE: If the hitch is being installed by a professional, the installer is responsible for training the end user in the use and maintenance of the product.

- **Accessory installation procedure:**
 1. Prepare latching mechanism. Turn handle clockwise if needed.
 2. Firmly insert "post" of accessory into latch block until handle spins counter-clockwise indicating that the accessory is latched.
 3. Always depress the safety locking pin and check that it has fully engaged.
- **Never use any accessory with the safety lock disengaged.** Until the safety locking pin is engaged, the handle is able to turn. A fully engaged safety locking pin is confirmation that the accessory is properly latched into the latch block.
- **Never use the rack receiver for towing.** The rack receiver accessory is only to be used with payload carrying products, such as bike racks or luggage racks.
- **Before each use, give the post of the accessory a light coating of lithium based grease.**
- **Before each use, inspect the hitch to ensure that all bolted connections are secure and that no cracks or damage are present.** Do not tow with the hitch if cracks or damage outside of normal wear is found.
- **Remove the Stealth accessories from the latch block after each use.** Do not leave accessories plugged in for extended periods of time.

SHR35004_(pn 2120-35004-2) 05 02 2024