



HITCH INSTALLATION INSTRUCTIONS

MAKE:
VOLVO

YEARS:
2016 - 2023
2016 - 2023
2022 - 2024

MODEL/TRIM:
XC90
XC90 Hybrid
XC90 Recharge

www.stealthhitches.com 833-694-4824

RACK RECEIVER KIT#: **SHR33006**

COMPATIBLE WITH TOW KIT: **SHT25034A**

2" RACK RECEIVER MAXIMUM PAYLOAD: 600 LBS
MAXIMUM TOW RATING: 6000 LBS
MAXIMUM TONGUE WEIGHT: 600 LBS

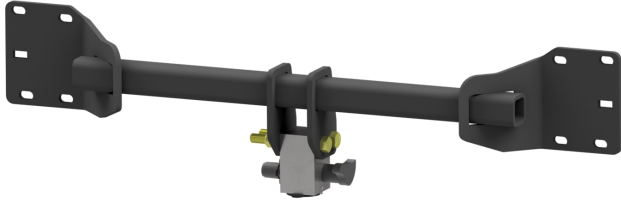

UNDER VEHICLE TRIMMING:

HEAT SHIELD: **YES**

FASCIA: **YES**

GRAVEL GUARD TRIMMING: **NO**



READ ALL INSTRUCTION WARNINGS AND LABELS



NO WELDING, METAL DRILLING OR VISIBLE TRIMMING REQUIRED

PARTS SUPPLIED WITH RACK RECEIVER KIT:



LATCH BLOCK & KEYS



(2) BOLTS
5/8"-11 x 5"



(2) 5/8"
NYLOCK NUTS



(2) M10 FLAT
WASHERS

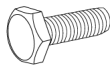

(2) M10 1.5 x
40mm BOLTS



(2) M10
NYLOCK NUTS



(2) M10 LOCK
WASHERS



(6) M10 SERRATED
FLANGE NUTS



2" RACK
RECEIVER



(12) TRIM CLIPS

ADDITIONAL PARTS FOR TOW KIT:



BALL MOUNT
5" RISE, SHORT



CHAIN HOOKS



2" BALL



ACTIVE WIRING KIT BOX

TOOLS REQUIRED:



15/16" OPEN
END WRENCH



15mm, 17mm DEEP
WELL, & 15/16"
SOCKETS



RATCHET

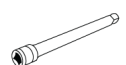

SOCKET
EXTENSION



TORQUE
WRENCH

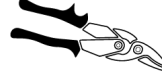

TIN SNIPS



FLASHLIGHT



PLASTIC
PRY TOOLS



SAFETY GLASSES



T25 TORX



DREMEL TOOL



FILE

ADDITIONAL TOOLS FOR ACTIVE TOW KIT:



MULTIMETER



STRIPPER/
CRIMPING
TOOL



PHILLIPS HEAD
SCREWDRIVER



10mm SOCKET

RACK RECEIVER INSTALLATION: USE STEPS 1-13, 31-36

ACTIVE TOW KIT INSTALLATION: USE STEPS 1-36

NOTICE: If installing an ACTIVE tow kit, the vehicle must be programmed at a Volvo Dealership before trailer lights will function. The last page of these instructions contain dealership programming instructions.

<THESE INSTRUCTIONS MUST BE GIVEN TO THE END USER>

NOTICE: Installation of Stealth products may or may not require the addition of a wiring harness to the vehicle.

- The Rack Receiver only product does not require adding a wiring harness.
- The Rack Receiver plus Tow Kit requires the addition a wiring harness that is compatible with the vehicle's wiring. The **Active Harness** plugs into the vehicle's wiring so that the vehicle's computer can communicate with the trailer wiring. This allows certain functions such as cameras or backup alarms to continue to operate as designed. Some active harnesses require reprogramming of the vehicle's computer before the trailer wiring is functional. Vehicles that require reprogramming need to be programmed at a dealership. Refer to the Active Harness section of the instructions to determine if programming is required for this install. ***This programming must be taken into account when planning the timing of the Stealth product install. The programming needs to be scheduled with a dealer in advance.***









INSTALLATION NOTE: In most instances, these instructions will only outline disassembly of vehicle components. Re-installation of components will require the installer to retain vehicle hardware and work through disassembly instructions in reverse order. When installation is complete, double check that all vehicle components have been replaced and are secured.

IMPORTANT SAFETY NOTICE FOR STEALTH HITCH INSTALLERS AND CUSTOMERS.

Read all installation and operating instructions along with all labels before installing or using this product. Do not perform any installation or towing procedures without fully understanding the correct tools and actions for all steps. Call for support if needed.

WARNING

Failure to comply with the safety information in these instructions could result in serious injury or death.

-  Do not modify this product in any manner. Doing so could alter its integrity and lead to a loss of attachment between the trailer and the tow vehicle.
-  Adding Stealth hitch components to the chassis of any vehicle can be hazardous. There is potential for unexpected combustion of fuel, electric shock, burns, shifting or falling of unstable vehicle, damage to vehicle, injury from tool usage and many other hazards. This installation must be completed by someone who is aware of the hazards involved. This person must be knowledgeable of proper safety procedures for a vehicle modification of this nature, and for usage of the equipment required to perform the installation.
-  Without proper knowledge, towing can be a dangerous activity. Understand all the risks involved with towing before proceeding. For information on towing safety, see "**The Trailer Handbook: A Guide to Understanding Trailer and Towing Safety**" from the National Association of Trailer Manufacturers, www.NATM.com and your trailer and tow vehicle manufacturer's owner's manual.
-  Do not exceed tow or tongue rating of coupler, tow or tongue rating of hitch, or tow or weight ratings of tow vehicle or trailer. See vehicle and trailer manufacturer information for ratings. Exceeding these ratings may cause damage to towing components or loss of attachment between the trailer and vehicle.
-  While installation is being performed, check for signs of damage or excessive corrosion. Do not install hitch components over vehicle parts that are broken or have compromised structural integrity.
-  This product was designed to fit vehicles in their original, "as manufactured" condition. Compatibility with vehicles having replacement parts, or other modifications is not guaranteed. Inspect vehicle for modifications before installation of this product.
-  Some accessories, like the rack receiver, are not rated for towing. Do not use any accessories without proper knowledge of their use.
-  A visual inspection of the hitch should be performed before each use. Regularly check that all connections are secure, including those that secure the hitch to the vehicle. Check for cracks or damage to the hitch. Do not use the hitch if cracks or damage outside of normal wear is found. Using a hitch that has unsecure connections and/or cracks or damage could result in damage to the tow vehicle, trailer, towing components and loss of attachment between the tow vehicle and trailer.
-  Stealth hitches are not compatible with any weight distribution or sway control products. Adding additional products to the trailer or chassis which modifies the function of the Stealth hitch may cause hitch failure.

NOTICE: Installation of hitch requires removal of vehicle parts and interaction with vehicular electronics. Before installation, check the condition of body panels and note any locations where panels are not flush. Check the electronic functions of the vehicle, such as: headlights, taillights, turn signals, cameras, backup sensors, Parking Distance Controller (PDC), foot activated cargo access, etc. It is the responsibility of the installer to restore the fit and function of the vehicle.

NOTICE: If installing the tow option, the vehicle must be programmed at a Volvo dealer after the hitch and wiring have been installed. Programming arrangement should be made in advance of installation. The 7-way plug will not function until programming is complete.

GAIN ACCESS TO MOUNTING AREA

1. Remove the trim piece around the top of the rear wheel wells. The trim pieces are fastened with plastic mounting clips. Apply outward pressure to release the clips. Start from the front of wheel well and continue around toward the rear.

NOTE: Limit bending to prevent distorting the shape of the trim.

NOTE: Replacement trim clips are provided if clips are broken during trim removal.

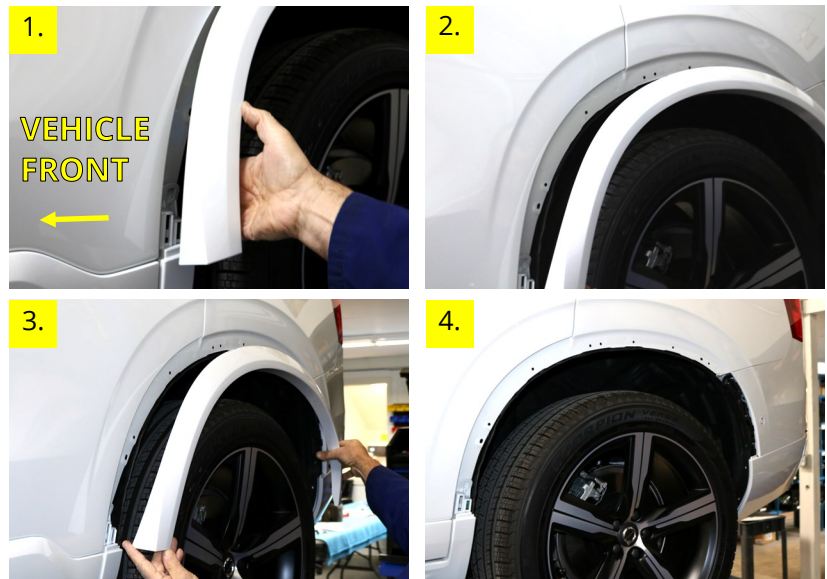

T25 TORX

2. Inside the rear portion of the rear wheel well, remove (5) screws attached to the rear fascia, see image.
3. Repeat Steps 1-2 on other side of vehicle.

NOTE: Some trim packages may include mud flaps. Remove (3) screws securing mud flap.



4. Open the rear hatch of the vehicle. Locate and remove the two rubber door bumpers in the door seam by turning them counter-clockwise.



GAIN ACCESS TO MOUNTING AREA CONTINUED



T25 TORX

5. Under the rear of the vehicle, remove (4) Torx screws from the bottom of the fascia.

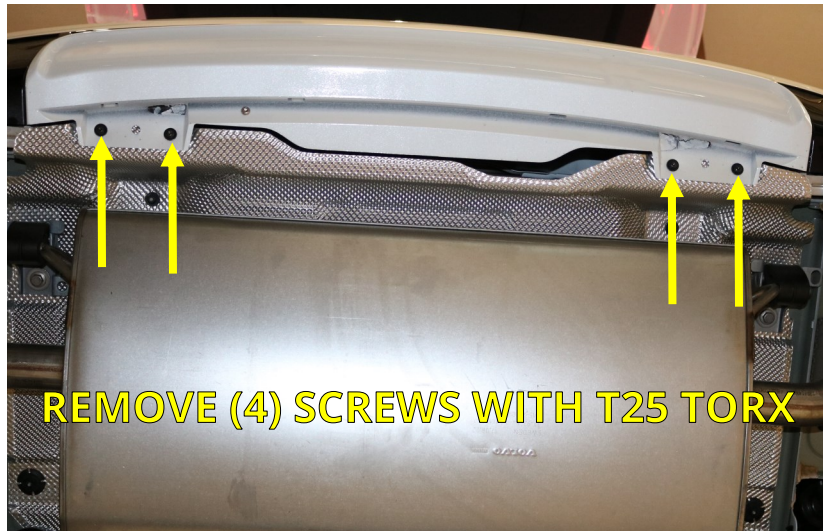

PLASTIC PRY TOOLS

6. Locate the (3) clips holding the fascia on each side of the vehicle directly behind the wheel wells. Release the clips using a plastic pry tool.



7. This step requires a partner. While supporting the fascia so it does not fall, carefully pull outward and rearward on each side of the fascia to release the final clips connecting the fascia to the vehicle. Start on the outside and work towards the center.



8. Pull the fascia rearward enough to access the electrical sensor plug on the passenger side. Press the clip to disconnect the electrical sensor plug. Remove the fascia.

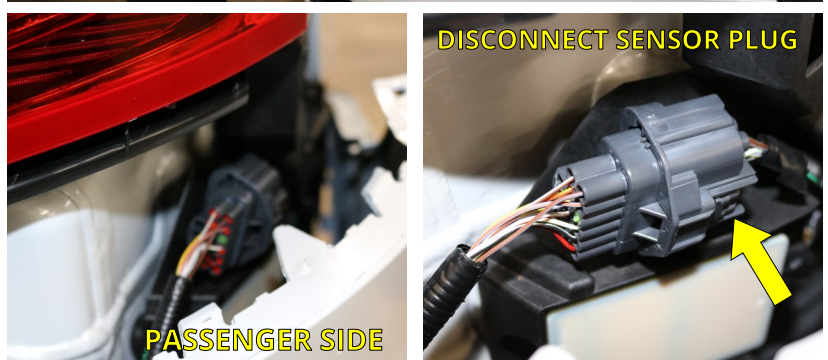

NOTICE: Carefully remove the fascia and place on a blanket or pad.

GAIN ACCESS TO MOUNTING AREA CONTINUED



9. With the fascia out of the way, locate and remove the (6) nuts attaching the factory reinforcement beam to the vehicle. **Save** the factory reinforcement beam for reinstallation. Discard the (6) factory nuts.

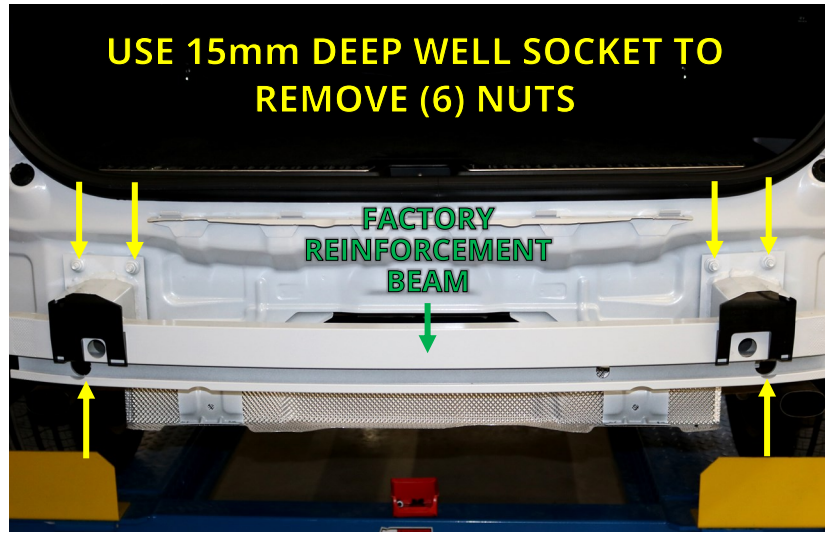

10. Under the area where the factory reinforcement beam was installed is a large aluminum heat shield. Use tin snips to trim the heat shield in two places, as shown. Fold the flap (between cut sides) down and back for clearance (blue line). Fold any exposed cut edges in to eliminate sharp edges.

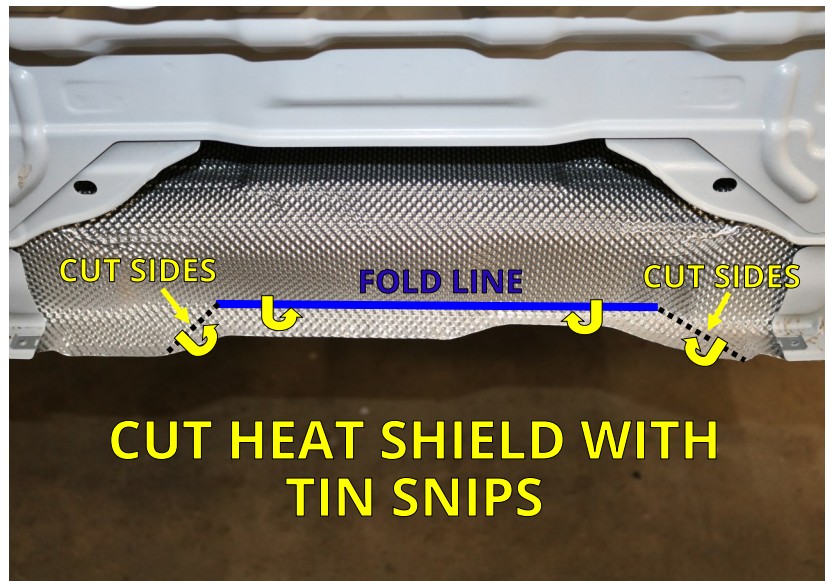

INSTALL STEALTH HITCH FRAME



11. Mount the Stealth hitch frame onto the vehicle studs and place the factory reinforcement beam on top. Attach the frame and beam to the vehicle with (6) supplied M10 serrated flange nuts. Torque each nut to 45 ft.-lbs.

12. Install two M10-40mm bolts into the two holes in the bottom of the beam. Use the provided M10 flat washers, lock washers and nylock nuts when installing the bolts. Torque to 45 ft.-lbs.

NOTE: Some vehicles have a weld nut in the bottom hole and will not need the nylock nut

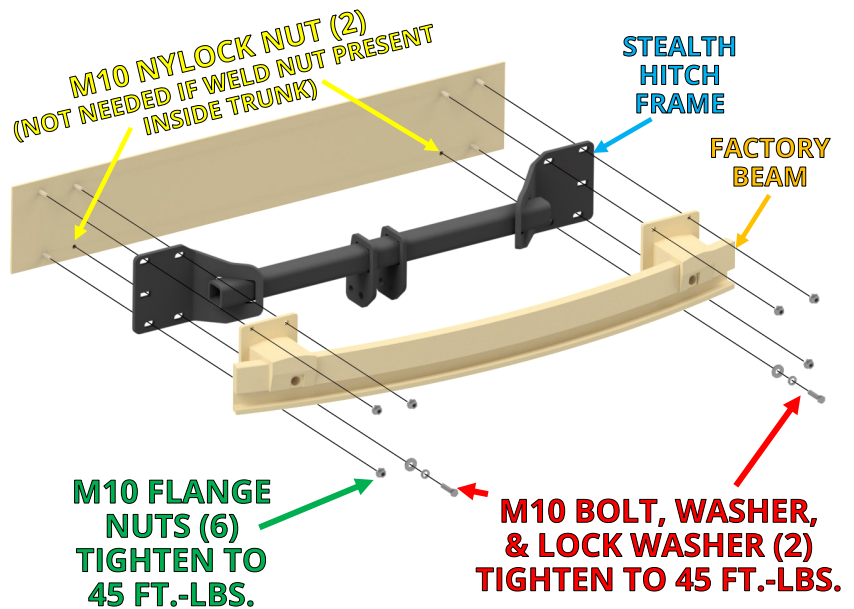

MOUNT LATCH BLOCK



15/16" SOCKET



15/16" OPEN END WRENCH



TORQUE WRENCH

13. Installation of the latch block varies depending on which kit you are installing.

- **Rack Receiver Kit:** Install the latch block with (2) 5/8"-11 x 5" bolts and (2) 5/8" nylock nuts. Tighten each bolt to 150 ft.-lbs.
- **Tow Kit:** Retrieve C-bracket from wiring harness kit box. Install the latch block, (2) chain hooks, and C-bracket with (2) 5/8"-11 x 5" bolts and (2) 5/8" nylock nuts. Tighten each bolt to 150 ft.-lbs.

NOTICE: Keys are packaged within the latch block, remove keys and store in safe location.



TOW KIT INSTALL

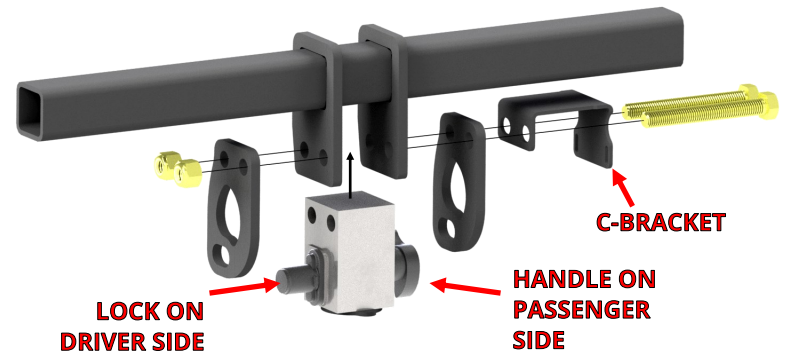

IF INSTALLING A RACK RECEIVER KIT, SKIP TO STEP 31.
IF INSTALLING A TOW KIT, CONTINUE TO STEP 14.

INSTALL ACTIVE WIRING KIT

#	DESCRIPTION	QTY
1	VOLVO TOW WIRING HARNESS	1
2	VOLVO TOW CONTROL MODULE	1
3	C-BRACKET	1
4	MOUNTING BRACKET	1
5	7-POLE HOUSING	1
6	7-POLE TO 4-POLE ADAPTER	1
7	ADHESIVE FOAM STRIP	2
8	#10 LOCK NUT	6
9	5/8" LONG PHILLIPS SCREWS	6
10	CABLE TIE - 8"	2
11	CABLE TIE - 14"	2
12	40 AMP FUSE	1



14. Locate the wiring kit box. Review the contents of the box against the list above to check for missing components. **The active wiring kit** uses a Volvo computer control module to manage the functions of the trailer lighting. The module must be “programmed” before it will be functional. The module will connect to the vehicle through an included wire harness. The harness has an “input” side that receives power and signals from the vehicle’s electronic systems. The “output” side of the harness delivers this information to the 7-way plug. The harness and computer module installation are outlined in the next steps.

NOTICE: Do not allow electrical system to become disconnected from power or ground. Doing so may interrupt electrical systems.

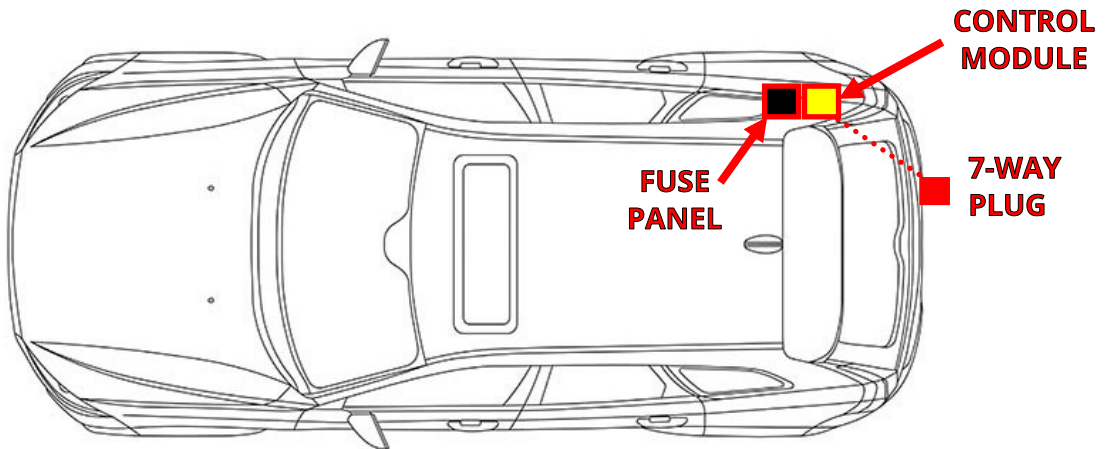

INSTALL WIRING KIT CONTINUED

15. Inside the rear cargo area remove the floor panel by lifting it up and out. Place panel on blanket in a safe area.



16. Remove the floor pan by lifting it up and out of the vehicle. Place the floor pan on blanket in safe area.



17. On the passenger side of the of the cargo compartment remove the side plastic storage compartment.



INSTALL WIRING KIT CONTINUED

18. Locate the green and grey wiring harness connectors under the area where the storage compartment was removed. The ends of the connectors may be covered in protective foam.

NOTE: Colors may vary.

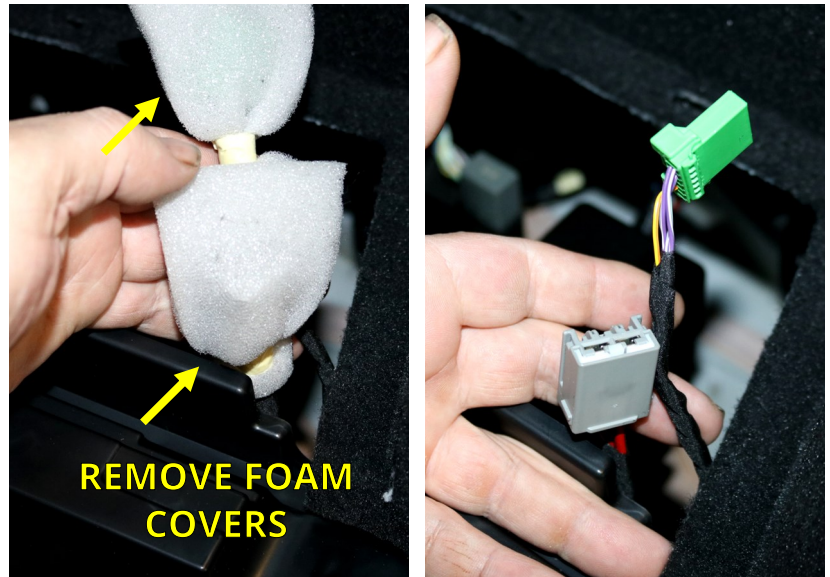

19. Retrieve the Volvo tow control module and wiring harness included with the wiring kit box. Plug the two vehicle wiring harness connectors and the wiring harness connector into the control module as shown.

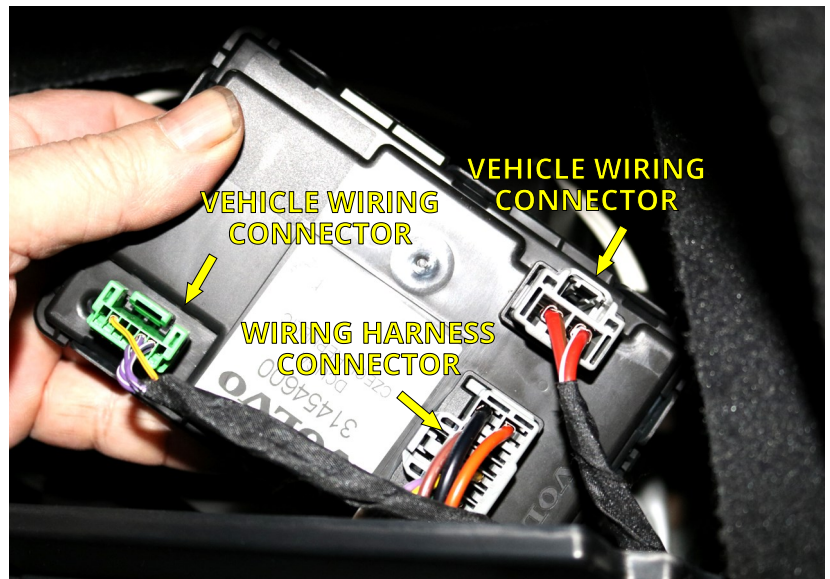

20. On the passenger outside of the vehicle, behind the rear tire, locate the grommet shown in the picture. Discard the grommet.

21. Route output wires of the wiring harness from inside of the vehicle to the outside through the hole where the grommet had been. Pull the wires out of the vehicle until the rubber grommet attached to the wiring harness is out of the hole. Securely seat the harness grommet into the hole.

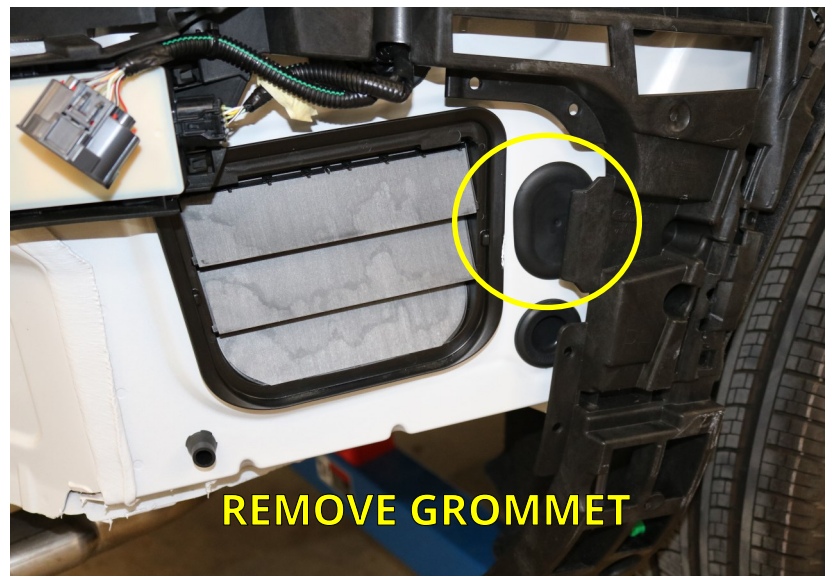

INSTALL WIRING KIT CONTINUED



10mm
SOCKET

22. Locate ground stud in the rear passenger side cargo area. Route the grounding ring from the wiring harness to the ground stud. Carefully remove the ground stud while keeping any vehicle wires in continuous contact with the stud. Place the ground ring connector over the stud. Replace the nut and tighten.

NOTICE: Do not allow vehicle wiring to lose ground contact.



USE 10mm SOCKET TO REMOVE
GROUND STUD NUT

WIRE 7-WAY PLUG



PHILLIPS HEAD
SCREWDRIVER

23. Locate the 7-way housing. Use a screwdriver to loosen (2) screws. Remove 7-way round terminal block. Place the mounting bracket onto the 7-way housing as shown. Use a screwdriver to loosen the set screw at the bottom of the 7-way housing. Route output side wires of the wiring harness through the 7-way housing.

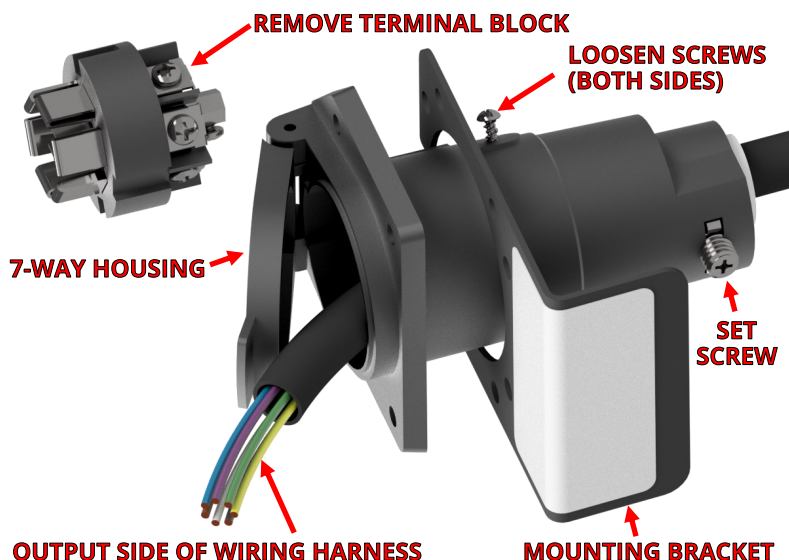

REMOVE TERMINAL BLOCK

LOOSEN SCREWS
(BOTH SIDES)

7-WAY HOUSING

SET
SCREW

OUTPUT SIDE OF WIRING HARNESS

MOUNTING BRACKET

Please follow instructions below very carefully.

Incorrect wiring of the 7-way receptacle causes the vast majority of wiring problems.



PHILLIPS HEAD
SCREWDRIVER



STRIPPER/
CRIMPING
TOOL

24. Locate the slot keyway. Starting from the keyway going **clockwise**, attach the wires as follows:

- Blue
- Green
- Black
- Brown
- Yellow
- White
- Purple (middle)

NOTICE: Markings on the receptacle may not match the correct wire configuration. Please disregard and follow the instruction above.

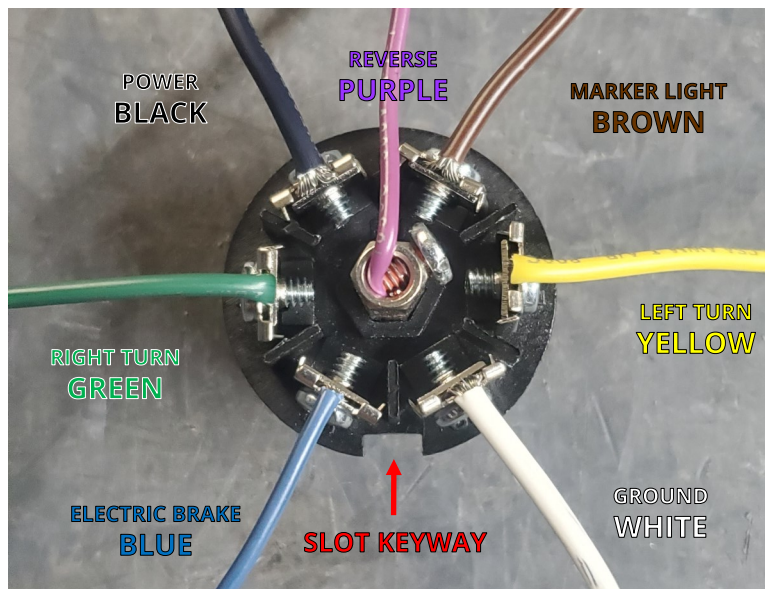

POWER
BLACK

REVERSE
PURPLE

MARKER LIGHT
BROWN

LEFT TURN
YELLOW

RIGHT TURN
GREEN

ELECTRIC BRAKE
BLUE

GROUND
WHITE

SLOT KEYWAY

INSTALL 7-WAY PLUG



PHILLIPS HEAD
SCREWDRIVER

25. Put the 7-way receptacle back together.
26. Attach the mounting bracket and 7-way housing to the Stealth hitch frame as shown. Secure harness to Stealth hitch frame with cable ties.
27. Secure all wires and wiring components. Use the remaining cable ties to secure wiring so that it is not loose and will not interfere with replacement of the fascia. Wiring should not be visible once the vehicle is reassembled.
28. Use the provided adhesive foam strips to secure the control module inside the passenger side cargo compartment.

NOTE: The dealer may need the information printed onto the Volvo tow control module to complete programming. Place the module in an orientation that can be easily read inside the compartment.

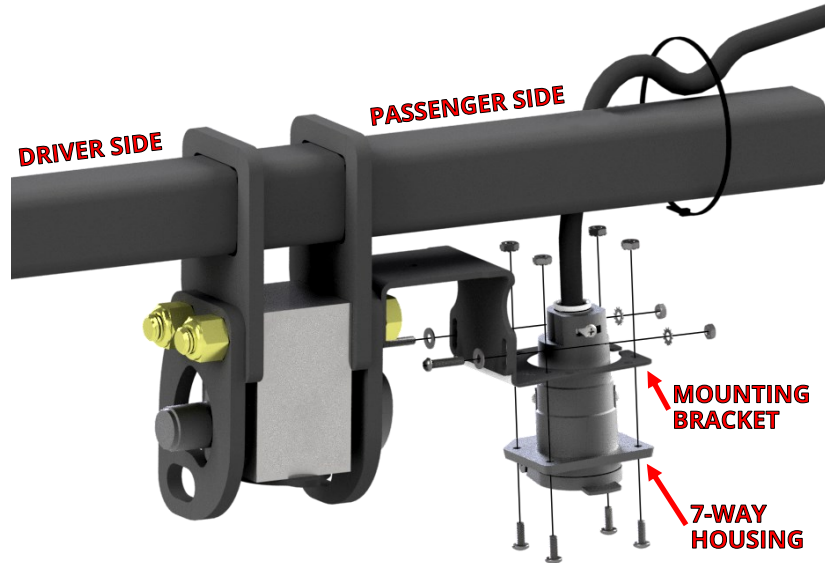

INSTALL FUSE

29. Locate the fuse box located on the passenger side of the cargo compartment. Unclip the panel cover to remove the cover to access the fuses.
30. Retrieve the 40 Amp fuse supplied with Volvo control module package. Insert fuse into the slot as shown.

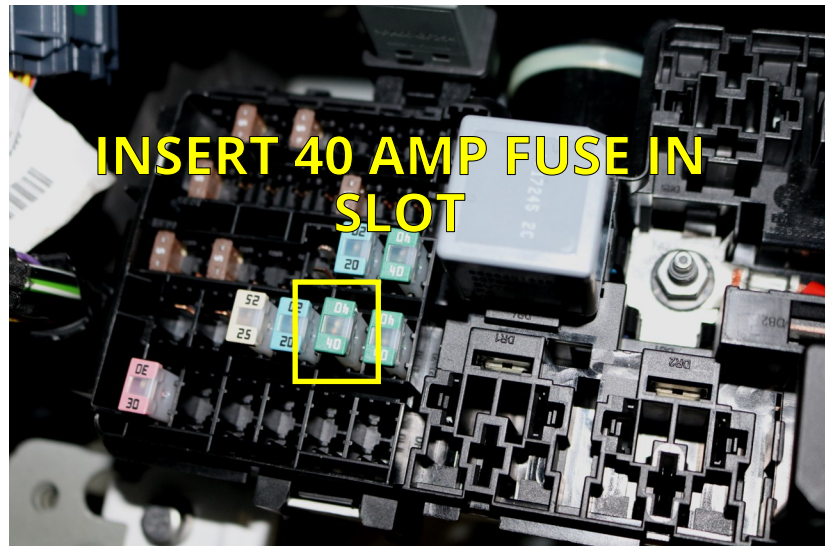

REINSTALL VEHICLE COMPONENTS



**IF INSTALL VEHICLE WAS MANUFACTURED BETWEEN 2016-2021 CONTINUE TO STEP 31
IF INSTALL VEHICLE WAS MANUFACTURED ON OR AFTER 2022 SKIP TO STEP 33.**



DREMEL TOOL



FILE

31. **2016-2021** Trim edge of fascia, as shown. Use a Dremel tool or something similar to make the cut. Use a file to smooth out the cut.

NOTE: Verify that there are no electrical components in the way before cutting.



32. **2016-2021** Reattach and secure the fascia, taillights, and other vehicle components in reverse order. Refer to Steps 1-8.

NOTICE: Remember to plug in the sensor plug in Step 8 before reinstalling the fascia.



- Reference image on right for view of completed fascia and heat shield modifications.



REINSTALL VEHICLE COMPONENTS

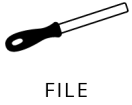

33. **2022+** Trim edge of fascia, as shown. Use a Dremel tool or something similar to make the cut. Use a file to smooth out the cut.

NOTE: Verify that there are no electrical components in the way before cutting.

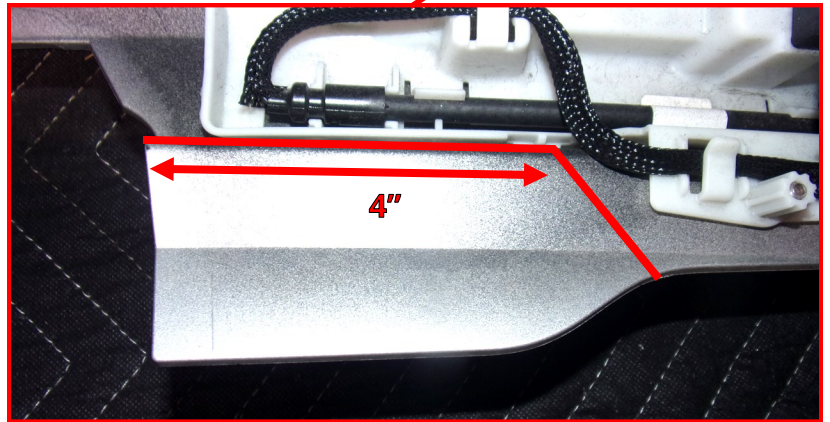
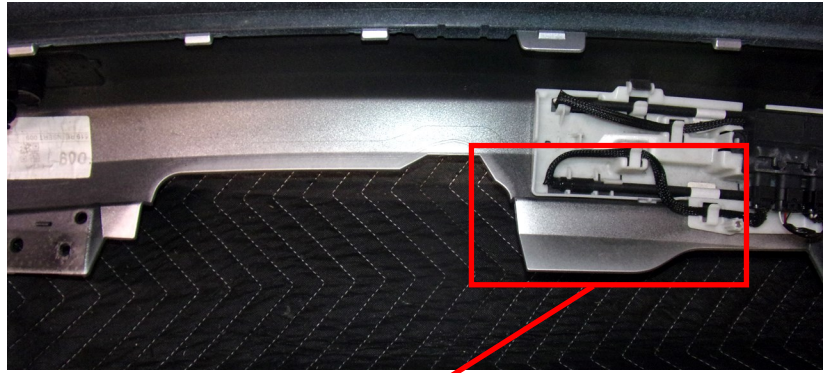

34. **2022+** Reattach and secure the fascia, taillights, and other vehicle components in reverse order. Refer to Steps 1-8.

NOTICE: Remember to plug in the sensor plug in Step 8 before reinstalling the fascia.



- Reference image on right for view of completed fascia and heat shield modifications.

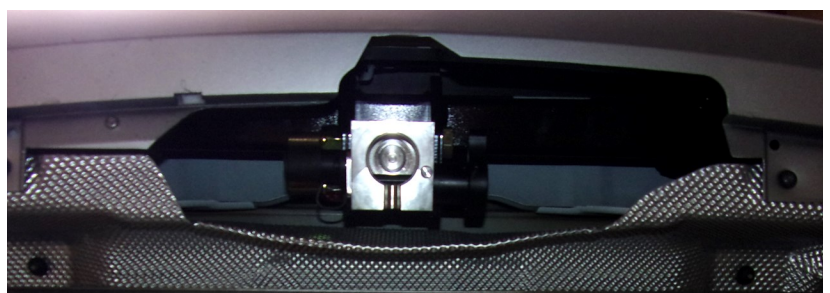

TEST 7-WAY HARNESS WIRING, PROGRAMMING MUST BE COMPLETED BEFORE TESTING.



MULTIMETER

- Start by connecting the multimeter negative probe to the ground blade on the 7-way receptacle.
- Next, connect the multimeter positive probe to the power blade on the 7-way receptacle and check for 12 volts.
- Once that is confirmed, move the positive probe to the left turn blade on the 7-way receptacle and check for 12 volts when the vehicle left turn blinker is active. You should see it pulse.
- Next, move the positive probe to the right turn blade and check for 12 volts when the right turn blinker is active. You should see it pulse.
- Next, move the positive probe to the marker/taillights. With the vehicle lights on you should see 12 volts constant.
- Lastly, with the brake depressed, move the positive probe to the left turn blade where you should see 12 volts constant. Move the probe to the right turn blade where you should also see 12 volts constant.

NOTICE: Most **Active** harness installations will require programming before testing can be completed. Testing Active wiring harness installations with a multimeter or LED tester may not work. Some vehicles may need to "sense" the current being used by the plug to function. After programming is complete, use an incandescent light testing device or trailer to test in these specific cases.

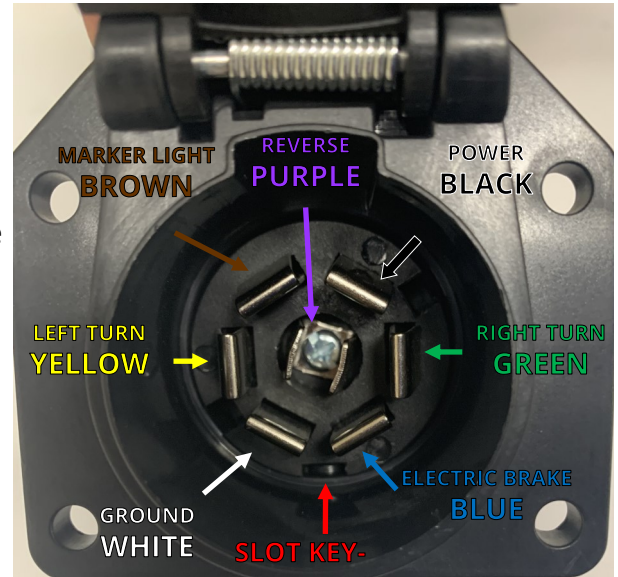

FINAL VEHICLE EXAMINATION

35. Examine the body panels to ensure that they are in a pre-installation condition. Test the electronic functions of the vehicle. Correct any inconsistencies.
36. Ensure that hitch components work properly.
 - **Verify that the lock works correctly.** Push in the safety lock on the latch block then unlock with key. The lock should slide back out with the key when unlocked.
 - **Verify that each accessory can be installed correctly.** Use the following steps to install and remove each accessory that will be used with the hitch. (*Rack Receiver and Ball Mount if purchased.*)
 1. Prepare latching mechanism. Turn handle clockwise if needed.
 2. Firmly insert "post" of accessory into latch block until handle releases indicating that the accessory is latched.
 3. Push in the safety locking pin until it fully engages. The locking pin prevents the handle from turning when pushed in, and confirms that the block is securely latched onto the accessory. The safety locking pin will not depress if the accessory is not fully latched.
 4. Use key to release safety locking pin.
 5. While holding on to the accessory, rotate handle clockwise to release and remove the accessory.
 - **Verify that no part of the accessories come into contact with the body of the vehicle.**

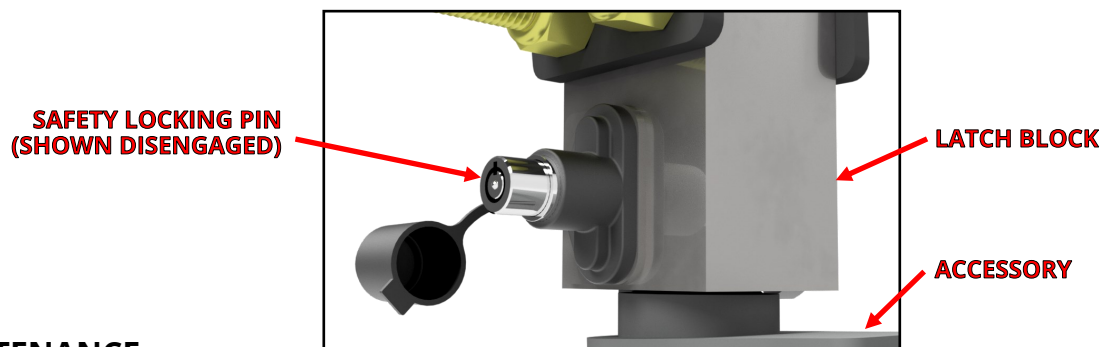

PRODUCT USE AND MAINTENANCE

NOTICE: If the hitch is being installed by a professional, the installer is responsible for training the end user in the use and maintenance of the product.

- **Accessory installation procedure:**
 1. Prepare latching mechanism. Turn handle clockwise if needed.
 2. Firmly insert "post" of accessory into latch block until handle spins counter-clockwise indicating that the accessory is latched.
 3. Always depress the safety locking pin and check that it has fully engaged.
- **Never use any accessory with the safety lock disengaged.** Until the safety locking pin is engaged, the handle is able to turn. A fully engaged safety locking pin is confirmation that the accessory is properly latched into the latch block.
- **Never use the rack receiver for towing.** The rack receiver accessory is only to be used with payload carrying products, such as bike racks or luggage racks.
- **Before each use, give the post of the accessory a light coating of lithium based grease.**
- **Before each use, inspect the hitch to ensure that all bolted connections are secure and that no cracks or damage are present.** Do not tow with the hitch if cracks or damage outside of normal wear is found.
- **Remove the Stealth accessories from the latch block after each use.** Do not leave accessories plugged in for extended periods of time.

SHR33006_(pn 2120-33006-2) 01 17 2024

PROGRAMMING VOLVO TRAILER CONTROL UNITS FOR VOLVO XC 90 ***SAVE THIS PAGE AND PRESENT TO VOLVO PROGRAMMING STAFF***

1. Must use OBD2 connector **9513108B** with an ethernet cable.
2. Install control module, fuse and ground per instructions.
3. Connect to vehicle to programming computer.
4. Go to **Software tab** and **New hardware tab** and see if software is available, if not continue to Step #5
5. Go to **Information Tab**
6. Click on **Installation instructions, accessories.**
7. Click on **Group #8** "BODY AND INTERIOR", then **Group #89** "MISCELLANEOUS", then **Group #892** "TOWING AND RECOVERY UNIT", then click "TOW BAR HITCH".
8. Scroll to almost the end and click on the software part number **31346719**
9. This will move the software to your cart, and you will perform the download as normal