



# HITCH INSTALLATION INSTRUCTIONS

**MAKE:** VOLVO      **YEARS:** 2017 - 2022  
 2017 - 2023      **MODEL/TRIM:** V90 (RACK ONLY)  
 V90 CROSS COUNTRY

www.stealthhitches.com 833-694-4824

RACK RECEIVER KIT#: **SHR33003**

COMPATIBLE WITH TOW KIT: **SHT25034A**



**2" RACK RECEIVER MAXIMUM PAYLOAD:** 600 LBS  
**MAXIMUM TOW RATING:** 6000 LBS  
**MAXIMUM TONGUE WEIGHT:** 600 LBS

### UNDER VEHICLE TRIMMING:

HEAT SHIELD: **NO**  
 FASCIA: **YES**  
 GRAVEL GUARD TRIMMING: **NO**



**READ ALL INSTRUCTION WARNINGS AND LABELS**



**NO WELDING, METAL DRILLING OR VISIBLE TRIMMING REQUIRED**

### PARTS SUPPLIED WITH RACK RECEIVER KIT:



LATCH BLOCK & KEYS

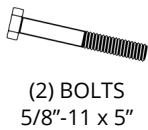

(2) BOLTS 5/8"-11 x 5"



(2) 5/8" NYLOCK NUTS

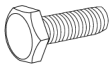

(2) M10 1.5 x 40mm BOLTS



(2) M10 LOCK WASHERS



(2) M10 FLAT WASHERS

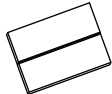

(1) DOUBLE SIDED TAPE



2" RACK RECEIVER



(1) 8" CABLE TIE

### ADDITIONAL PARTS FOR TOW KIT:



BALL MOUNT 5" RISE, SHORT



CHAIN HOOKS



2" BALL

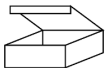

ACTIVE WIRING HARNESS KIT BOX

### TOOLS REQUIRED:



15/16" OPEN END WRENCH



15mm DEEP WELL & 15/16" SOCKETS



RATCHET

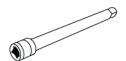

SOCKET EXTENSION



TORQUE WRENCH



T25 TORX



FLASHLIGHT



PLASTIC PRY TOOLS



SAFETY GLASSES



DREMEL TOOL



FILE



DRILL & 1/4" BIT 2022+ MODELS



T30 TORX 2022+ MODELS

### ADDITIONAL TOOLS FOR ACTIVE TOW KIT:



STRIPPER/CRIMPING TOOL



8mm & 10mm SOCKETS



PHILLIPS HEAD SCREWDRIVER



FLATHEAD SCREWDRIVER



MULTIMETER

**RACK RECEIVER INSTALLATION:** USE STEPS 1-9, & 28-35

**ACTIVE TOW KIT INSTALLATION:** USE STEPS 1-35

**NOTICE: If installing an ACTIVE tow kit, the vehicle must be programmed at a Volvo Dealership before trailer lights will function. The last page of these instructions contain dealership programming instructions.**

# <THESE INSTRUCTIONS MUST BE GIVEN TO THE END USER>

NOTICE: Installation of Stealth products may or may not require the addition of a wiring harness to the vehicle.

- The Rack Receiver only product does not require adding a wiring harness.
- The Rack Receiver plus Tow Kit requires the addition a wiring harness that is compatible with the vehicle's wiring. The **Active Harness** plugs into the vehicle's wiring so that the vehicle's computer can communicate with the trailer wiring. This allows certain functions such as cameras or backup alarms to continue to operate as designed. Some active harnesses require reprogramming of the vehicle's computer before the trailer wiring is functional. Vehicles that require reprogramming need to be programmed at a dealership. Refer to the Active Harness section of the instructions to determine if programming is required for this install. ***This programming must be taken into account when planning the timing of the Stealth product install. The programming needs to be scheduled with a dealer in advance.***









**INSTALLATION NOTE:** In most instances, these instructions will only outline disassembly of vehicle components. Re-installation of components will require the installer to retain vehicle hardware and work through disassembly instructions in reverse order. When installation is complete, double check that all vehicle components have been replaced and are secured.

## IMPORTANT SAFETY NOTICE FOR STEALTH HITCH INSTALLERS AND CUSTOMERS.

Read all installation and operating instructions along with all labels before installing or using this product. Do not perform any installation or towing procedures without fully understanding the correct tools and actions for all steps. Call for support if needed.

### **WARNING**

**Failure to comply with the safety information in these instructions could result in serious injury or death.**

-  Do not modify this product in any manner. Doing so could alter its integrity and lead to a loss of attachment between the trailer and the tow vehicle.
-  Adding Stealth hitch components to the chassis of any vehicle can be hazardous. There is potential for unexpected combustion of fuel, electric shock, burns, shifting or falling of unstable vehicle, damage to vehicle, injury from tool usage and many other hazards. This installation must be completed by someone who is aware of the hazards involved. This person must be knowledgeable of proper safety procedures for a vehicle modification of this nature, and for usage of the equipment required to perform the installation.
-  Without proper knowledge, towing can be a dangerous activity. Understand all the risks involved with towing before proceeding. For information on towing safety, see "**The Trailer Handbook: A Guide to Understanding Trailer and Towing Safety**" from the National Association of Trailer Manufacturers, [www.NATM.com](http://www.NATM.com) and your trailer and tow vehicle manufacturer's owner's manual.
-  Do not exceed tow or tongue rating of coupler, tow or tongue rating of hitch, or tow or weight ratings of tow vehicle or trailer. See vehicle and trailer manufacturer information for ratings. Exceeding these ratings may cause damage to towing components or loss of attachment between the trailer and vehicle.
-  While installation is being performed, check for signs of damage or excessive corrosion. Do not install hitch components over vehicle parts that are broken or have compromised structural integrity.
-  This product was designed to fit vehicles in their original, "as manufactured" condition. Compatibility with vehicles having replacement parts, or other modifications is not guaranteed. Inspect vehicle for modifications before installation of this product.
-  Some accessories, like the rack receiver, are not rated for towing. Do not use any accessories without proper knowledge of their use.
-  A visual inspection of the hitch should be performed before each use. Regularly check that all connections are secure, including those that secure the hitch to the vehicle. Check for cracks or damage to the hitch. Do not use the hitch if cracks or damage outside of normal wear is found. Using a hitch that has unsecure connections and/or cracks or damage could result in damage to the tow vehicle, trailer, towing components and loss of attachment between the tow vehicle and trailer.
-  Stealth hitches are not compatible with any weight distribution or sway control products. Adding additional products to the trailer or chassis which modifies the function of the Stealth hitch may cause hitch failure.

**NOTICE:** Installation of hitch requires removal of vehicle parts and interaction with vehicular electronics. Before installation, check the condition of body panels and note any locations where panels are not flush. Check the electronic functions of the vehicle, such as: headlights, taillights, turn signals, cameras, backup sensors, Parking Distance Controller (PDC), foot activated cargo access, etc. It is the responsibility of the installer to restore the fit and function of the vehicle.

**NOTICE:** If installing the tow option on the Volvo Cross Country, the vehicle must be programmed at a Volvo dealer after the hitch and wiring have been installed. Programming arrangement should be made in advance of installation. The 7-way plug will not function until programming is complete.

**Dealer must program with alternate Volvo software:** Installed Control Module #: **31454602**

Software #: **31435638** Software Description: **Towing Hook 4-7 Pole Application.**

***The standard V90 Cross Country software will not work and must be substituted with #31435638***

## GAIN ACCESS TO MOUNTING AREA

1. Open the rear hatch of the vehicle. Locate and remove the (2) rubber door bumpers in the door seam by turning them counterclockwise.



2. Inside the rear portion of the rear wheel well, remove (5) screws attached to the rear fascia, see image.



3. Inside the wheel well where the screws were removed, move the wheel well liner aside to gain access to (1) screw. Remove the screw. Remove plastic clip by releasing the catch. Lift the plastic clip upward to remove. Repeat Steps 2-3 on other side of vehicle.



## GAIN ACCESS TO MOUNTING AREA CONTINUED



T25 TORX

4. Under the rear of the vehicle, remove (4) Torx screws from the bottom of the fascia.

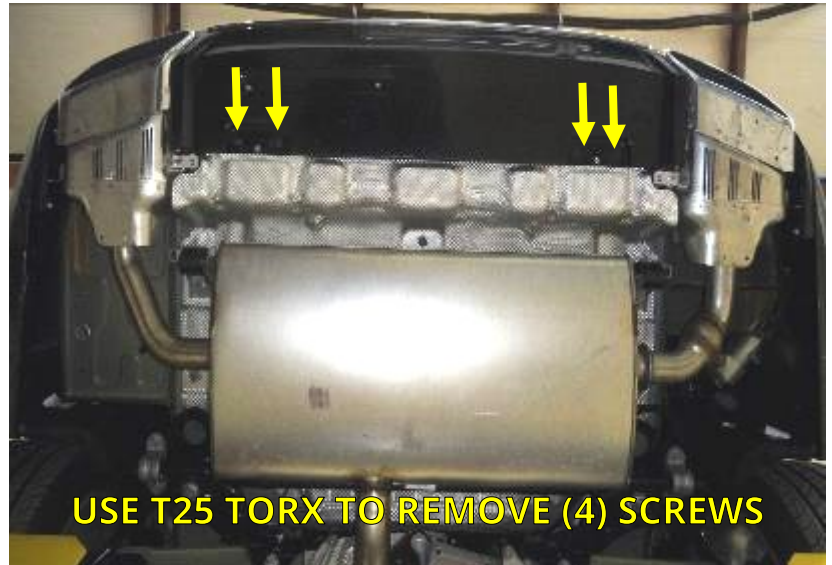

5. This step requires a partner. While supporting the fascia so it does not fall, carefully pull outward and rearward on each side of the fascia to release the final clips connecting the fascia to the vehicle. Start on the outside and work towards the center.

**Note:** Keep the fascia close to the vehicle, until the electrical sensor plugs are disconnected.



6. Pull the fascia rearward enough to access the electrical sensor plug on each side of the vehicle. Press the clip to disconnect the electrical sensor plugs. Remove the fascia.

**NOTICE:** Carefully remove the fascia and place on a blanket or pad.

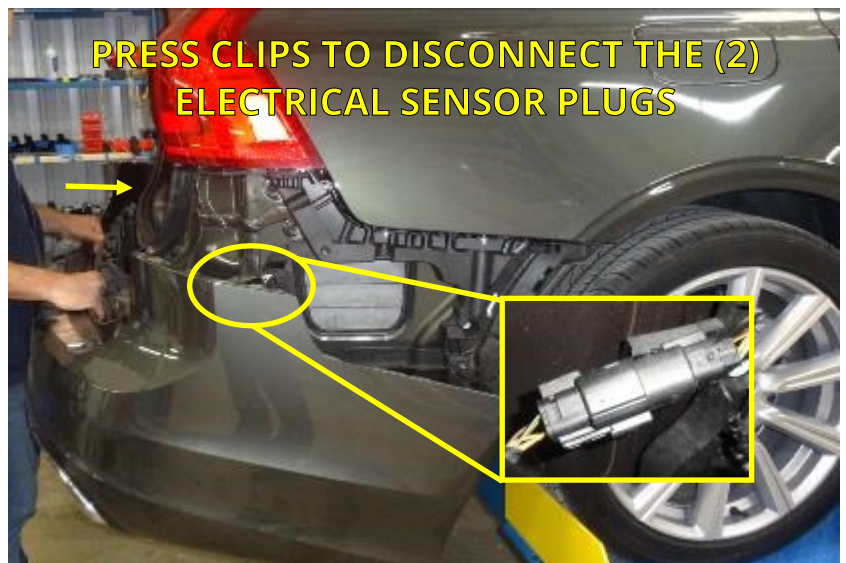

## GAIN ACCESS TO MOUNTING AREA



15mm  
DEEP WELL  
SOCKET

- With the fascia out of the way, locate and remove the (6) nuts attaching the factory reinforcement beam to the vehicle. **Discard** the factory reinforcement beam. **Save** the (6) factory nuts.



USE 15mm SOCKET TO REMOVE (6) NUTS

## INSTALL STEALTH HITCH FRAME



15mm  
DEEP WELL  
SOCKET



17mm  
SOCKET

- Mount the Stealth hitch frame onto the vehicle studs, attach the frame to the vehicle with the (6) saved factory nuts. Use the (2) supplied M10 bolts, washers, & lock washers in the remaining hole on each side of the hitch frame. Torque each bolt and nut to 45 ft.-lbs.

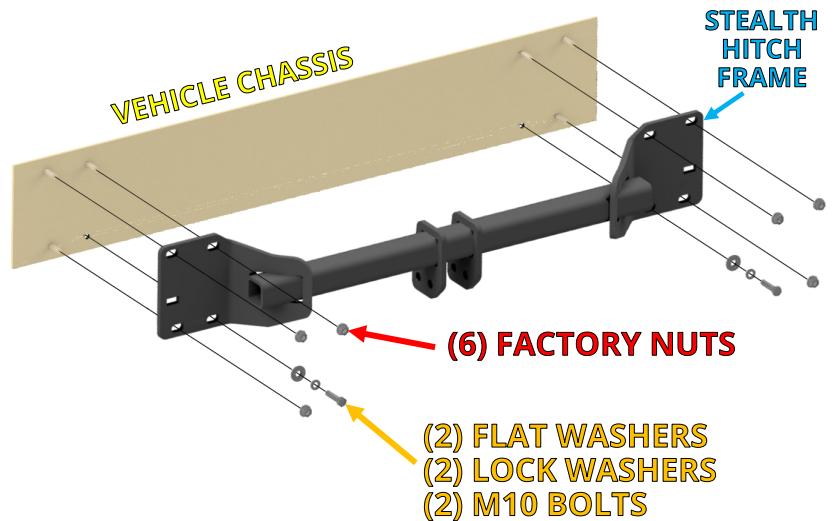

## MOUNT LATCH BLOCK



15/16"  
SOCKET



15/16" OPEN  
END WRENCH



TORQUE  
WRENCH

- Installation of the latch block varies depending on which kit you are installing.
  - Rack Receiver Kit:** Install the latch block with (2) 5/8"-11 x 5" bolts and (2) 5/8" nylock nuts. Tighten each bolt to 150 ft.-lbs.
  - Tow Kit:** Retrieve C-bracket from wiring harness kit box. Install the latch block, (2) chain hooks, and C-bracket with (2) 5/8"-11 x 5" bolts and (2) 5/8" nylock nuts. Tighten each bolt to 150 ft.-lbs.

**NOTICE:** Keys are packaged within the latch block, remove keys and store in safe location.

### RACK RECEIVER KIT INSTALL



### TOW KIT INSTALL

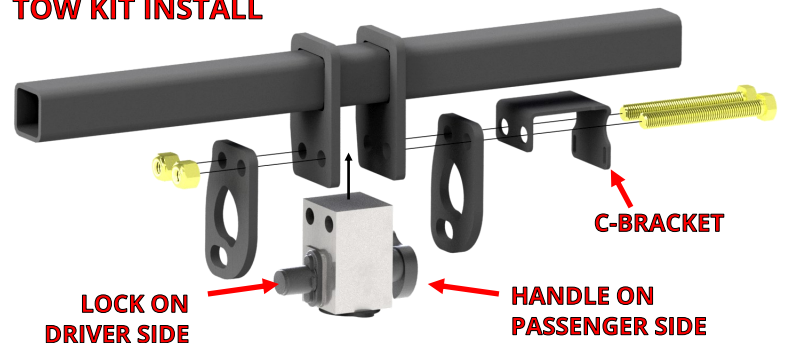

IF INSTALLING A RACK RECEIVER KIT, SKIP TO STEP 28.

IF INSTALLING A TOW KIT, CONTINUE TO STEP 10. (CROSS COUNTRY ONLY)

## INSTALL ACTIVE WIRING KIT

#	DESCRIPTION	QTY
1	VOLVO TOW WIRING HARNESS	1
2	VOLVO TOW CONTROL MODULE	1
3	C-BRACKET	1
4	MOUNTING BRACKET	1
5	7-POLE HOUSING	1
6	7-POLE TO 4-POLE ADAPTER	1
7	ADHESIVE FOAM STRIP	2
8	#10 LOCK NUT	6
9	5/8" LONG PHILLIPS SCREWS	6
10	CABLE TIE - 8"	2
11	CABLE TIE - 14"	2
12	40 AMP FUSE	1

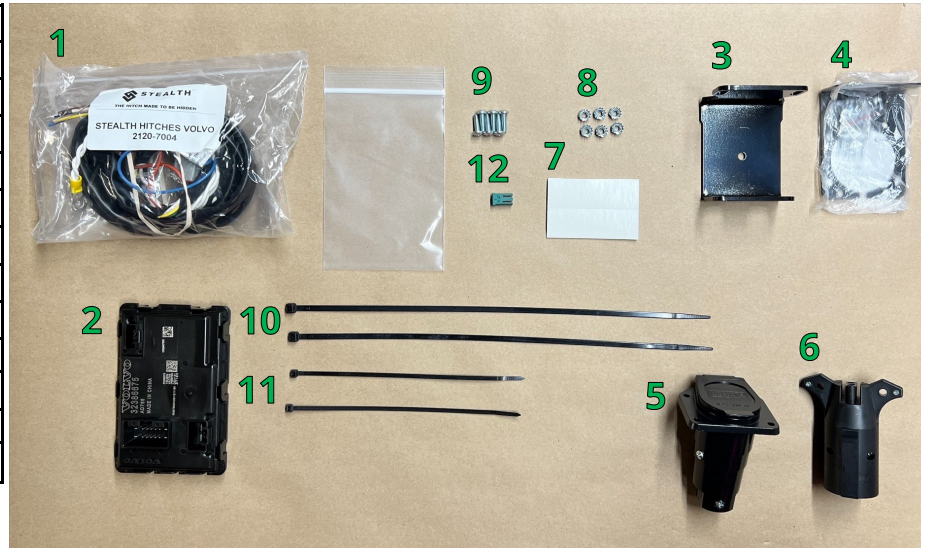

10. Locate the wiring kit box. Review the contents of the box against the list above to check for missing components. **The active wiring kit** uses a Volvo computer control module to manage the functions of the trailer lighting. The module must be “programmed” before it will be functional. The module will connect to the vehicle through an included wire harness. The harness has an “input” side that receives power and signals from the vehicle’s electronic systems. The “output” side of the harness delivers this information to the 7-way plug. The harness and computer module installation are outlined in the next steps.

**NOTICE: Do not allow electrical system to become disconnected from power or ground. Doing so may interrupt electrical systems.**

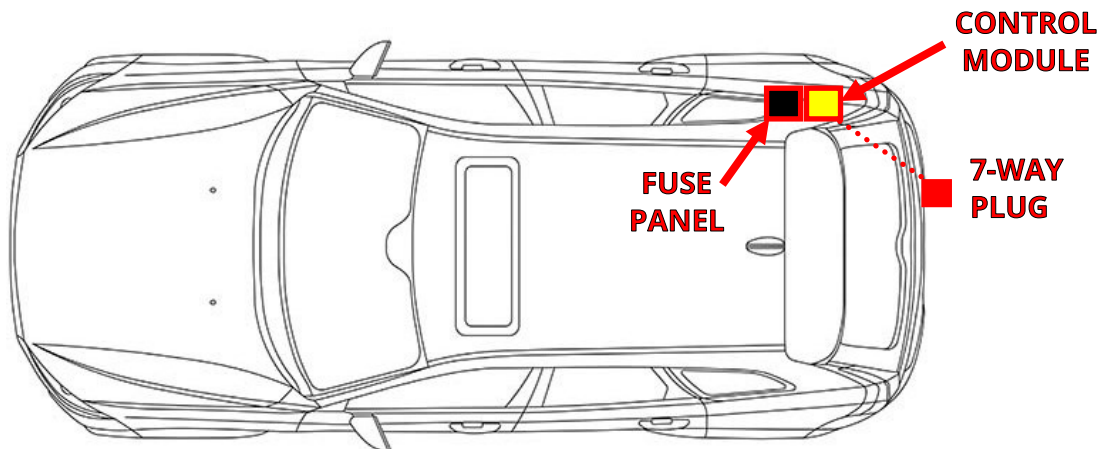

## INSTALL WIRING HARNESS



FLATHEAD  
SCREWDRIVER

11. Lift up the cargo area floor panel to gain access to lift support strut shock. Use a flathead screwdriver to pry the metal clip outward to remove clip. Remove the cargo area floor panel by lifting up and out. Place panel on blanket or safe area.

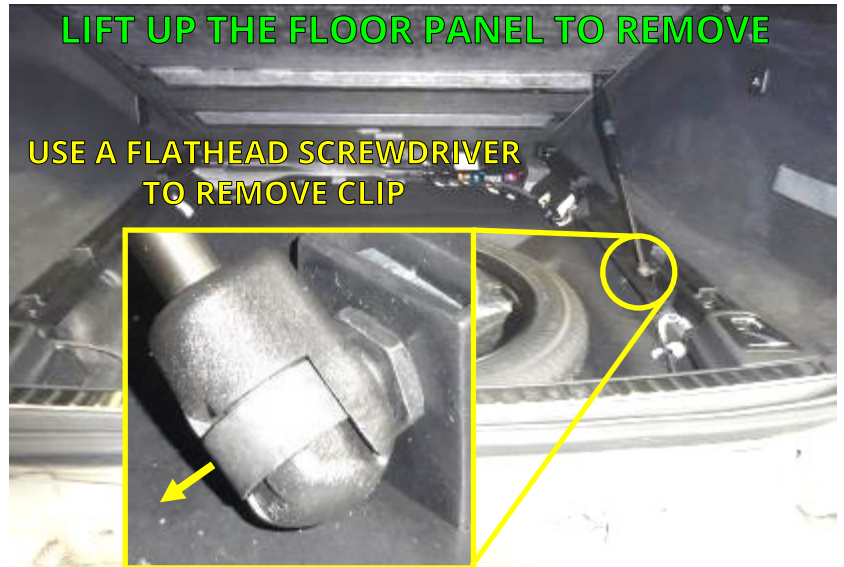

PLASTIC  
PRY TOOLS

12. Locate the rear passenger side seatbelt cover. It is located over the area where the seat belt retracts into the vehicle. Use a plastic pry tool to release clips holding the seat belt cover by prying upward.



8mm  
SOCKET

13. Under the removed cover, Use a socket to remove (1) screw from the plastic seat belt holder. Pull up on the plastic holder to release (3) clips. Remove plastic seat belt holder.



## INSTALL WIRING HARNESS CONTINUED



14. Behind the passenger side door, remove the leather trim piece. Disconnect the trim piece by releasing the latch under the top portion of the trim piece.



15. Locate and dislodge the side panel on the passenger side wall of the rear cargo compartment. The panel is connected by (5) clips. Release the clips and pull the panel inward to dislodge the panel.



16. Before completely removing the panel, disconnect (3) plugs from the backside of the panel, then, Remove panel.





## INSTALL WIRING HARNESS CONTINUED

17. Locate the vehicle wiring harness in the passenger side compartment. The ends of the connectors may be covered in foam.



18. Retrieve the Volvo tow control module and wiring harness included with the wiring kit box. Plug the two vehicle wiring harness connectors and the wiring harness connector into the control module as shown.

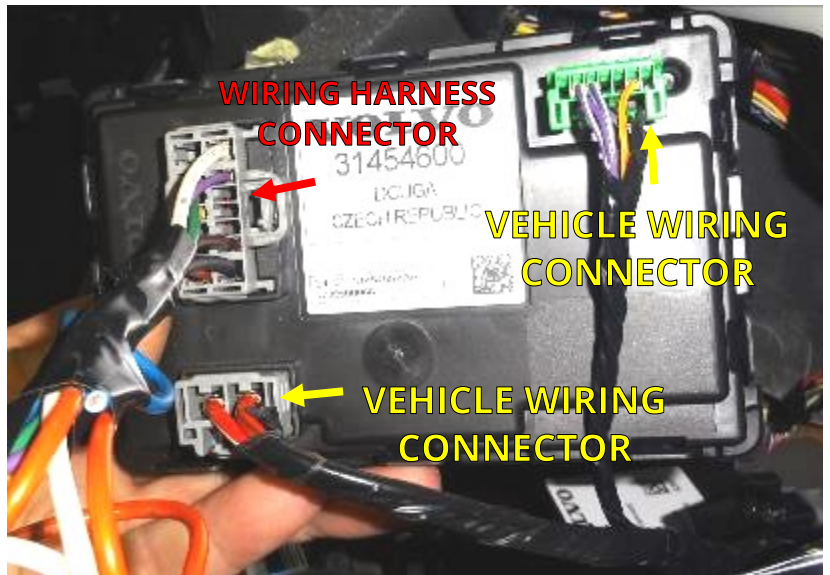

19. Use the supplied adhesive foam strips to secure the control module, on the passenger side, in the location shown in the photo.

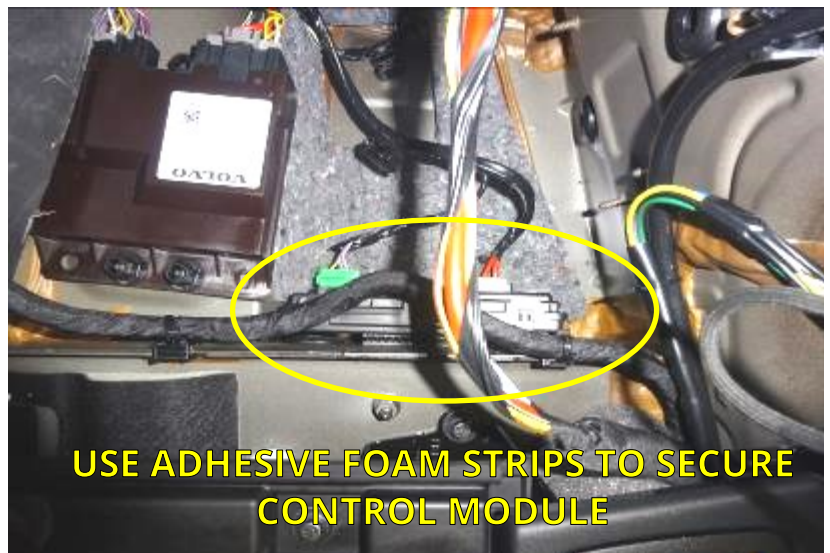

## INSTALL WIRING HARNESS CONTINUED

20. Locate the oval grommet on the rear wall of the vehicle. Remove and discard the grommet. Route output wires of the wiring harness from inside of the vehicle to the outside through the hole where the grommet was. Pull the wires out of the vehicle until the rubber grommet attached to the wiring harness is out of the hole. Securely seat the harness grommet into the hole.

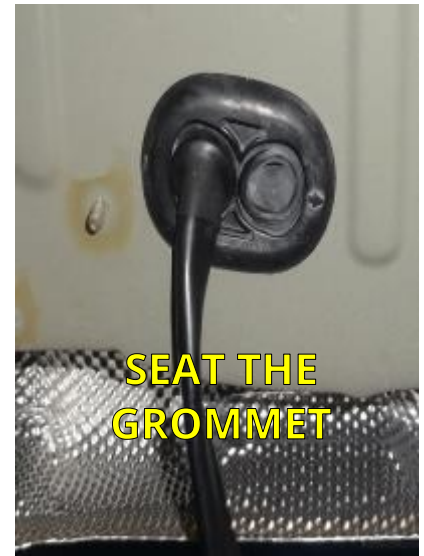
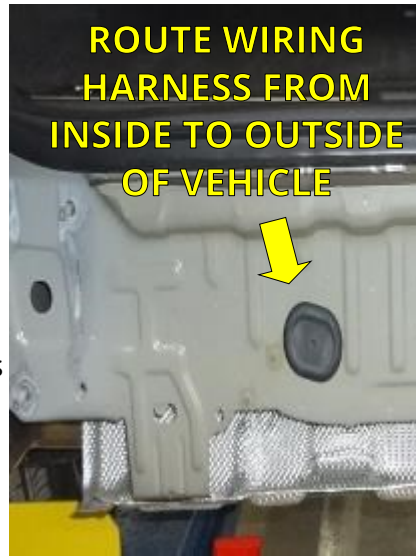

10mm  
SOCKET

21. Locate ground stud in the rear passenger side cargo area. Route the grounding ring from the wiring harness to the ground stud. Carefully remove the ground stud while keeping any vehicle wires in continuous contact with the stud. Place the ground ring connector over the stud. Replace the nut and tighten.

**NOTICE: Do not allow vehicle wiring to lose ground contact.**

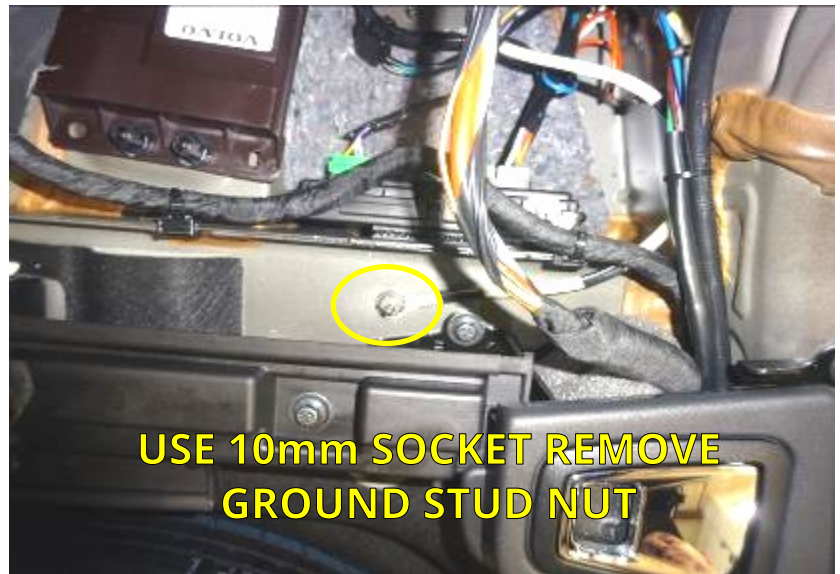

## WIRE 7-WAY PLUG



PHILLIPS HEAD  
SCREWDRIVER

22. Locate the 7-way housing. Use a screwdriver to loosen (2) screws. Remove 7-way round terminal block. Place the mounting bracket onto the 7-way housing as shown. Use a screwdriver to loosen the set screw at the bottom of the 7-way housing. Route output side wires of the wiring harness through the 7-way housing.

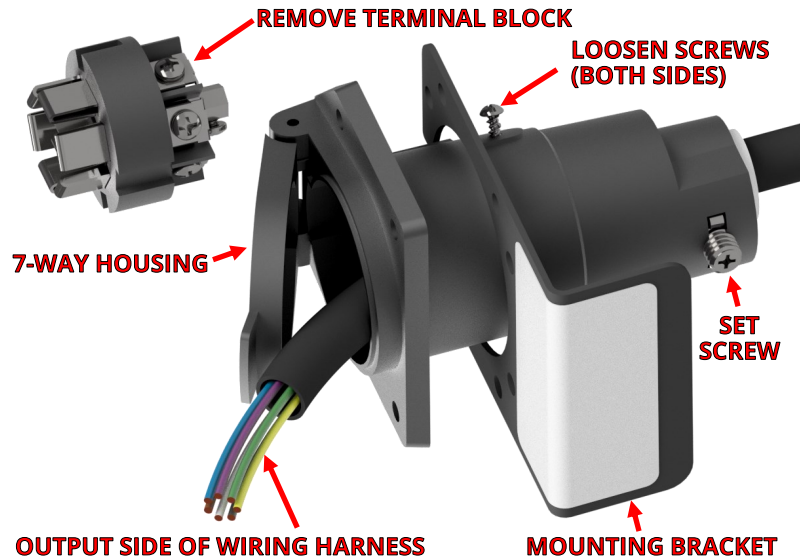

## WIRE 7-WAY PLUG CONTINUED

**Please follow instructions below very carefully.**

**Incorrect wiring of the 7-way receptacle causes the vast majority of wiring problems.**



PHILLIPS HEAD  
SCREWDRIVER

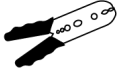

STRIPPER/  
CRIMPING  
TOOL

23. Locate the slot keyway. Starting from the keyway going **clockwise**, attach the wires as follows:

- Blue
- Green
- Black
- Brown
- Yellow
- White
- Purple (middle)

***NOTICE: Markings on the receptacle may not match the correct wire configuration. Please disregard and follow the instruction above.***

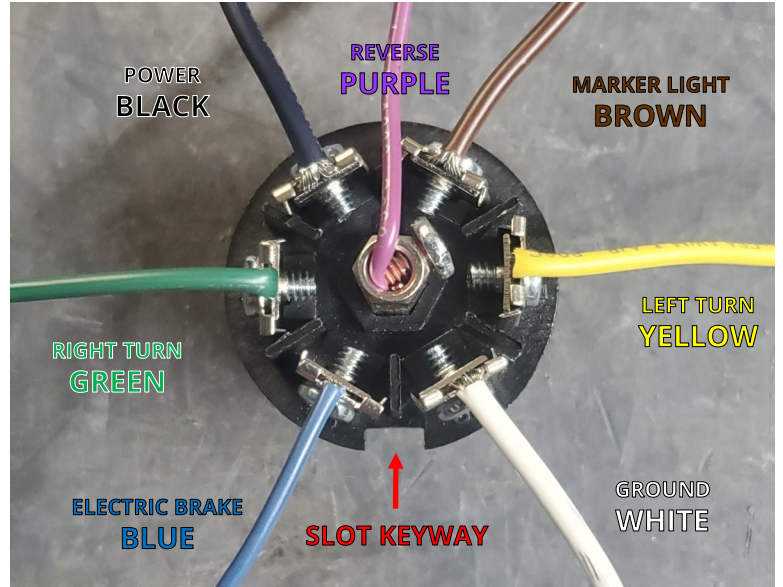

## MOUNT 7-WAY HARNESS



PHILLIPS HEAD  
SCREWDRIVER

24. Put the 7-way receptacle back together.

25. Attach the mounting bracket and 7-way housing to the Stealth hitch frame as shown. Secure harness to Stealth hitch frame with cable ties.

26. Secure all wires and wiring components. Use the remaining cable ties to secure wiring so that it is not loose and will not interfere with replacement of the fascia. Wiring should not be visible once the vehicle is reassembled.

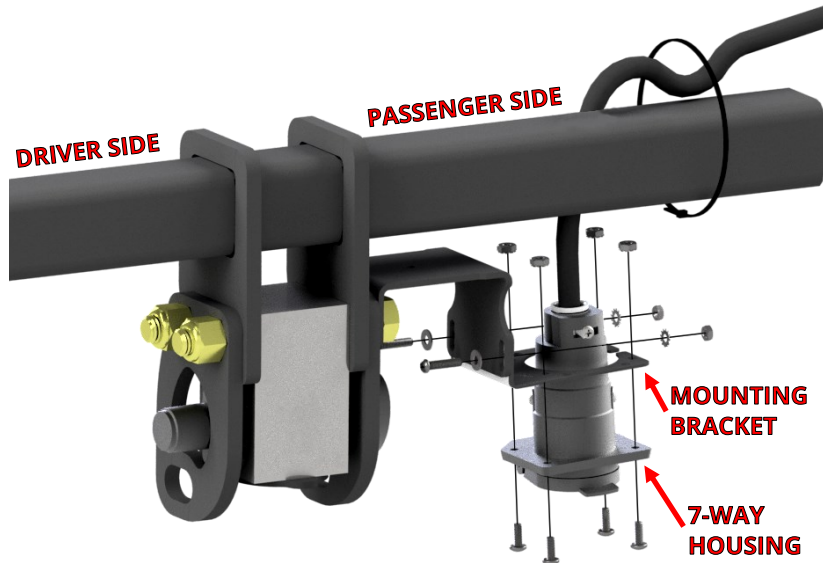

## INSTALL FUSE

27. Locate the fuse box on the passenger side of the cargo compartment. Retrieve the 40 Amp fuse supplied with Volvo control module package. Insert fuse into the slot as shown.



## CUT ACCESS HOLE IN FASCIA



**IF INSTALLING ON 2017 - 2021 MODEL YEAR VEHICLES CONTINUE TO STEP 28. IF INSTALLING ON 2022 OR NEWER MODEL YEAR VEHICLES, SKIP TO STEP 29.**



DREMEL TOOL



FILE

28. **(2017-2021)** Trim the bottom of the fascia, as shown, with Dremel tool. Use a file to smooth out the cut.

**NOTE:** The cut out necessary for the tow kit is larger on the passenger side than the rack receiver kit.

**NOTE:** Verify that there are no electrical components in the way before cutting.

- Reference image on right for view of completed fascia modification. Tow kit installation shown.

**SKIP TO STEP 33.**

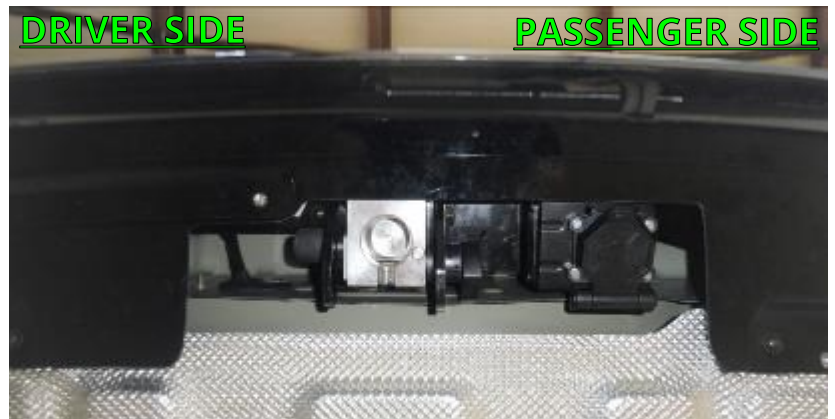
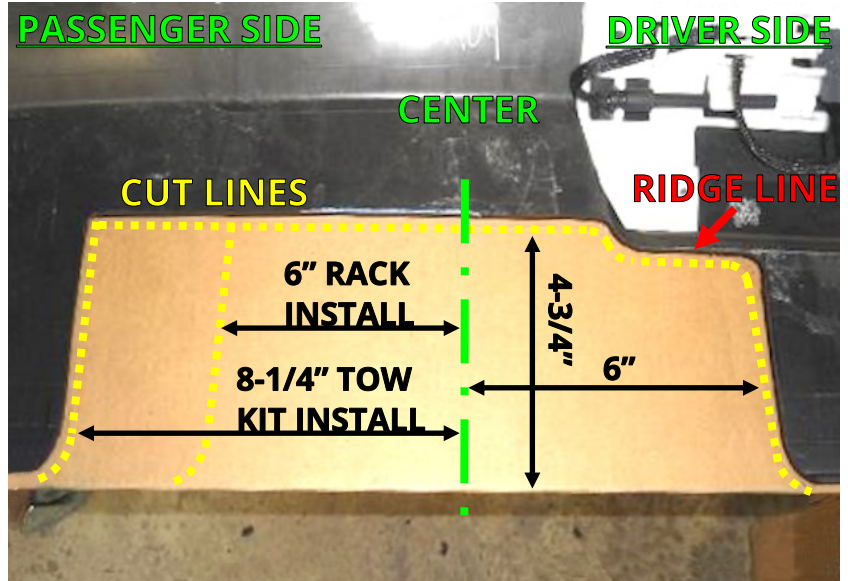

T30 TORX

29. **(2022+)** To allow access to the locking mechanism the factory cutout in the fascia needs to be extended and the kick wand holder relocated. Under the fascia locate and remove the two indicated screws with a Torx socket. Save (1) screw for later reinstallation.



## CUT ACCESS HOLE IN FASCIA



DRILL &  
1/4" BIT

30. On the inside of the fascia, move the detached kick wand holder out of the way. Drill a 1/4" hole 3" from the screw hole closest to the fascia cutout as shown. Temporarily re-attach the kick wand holder through the newly drilled hole.

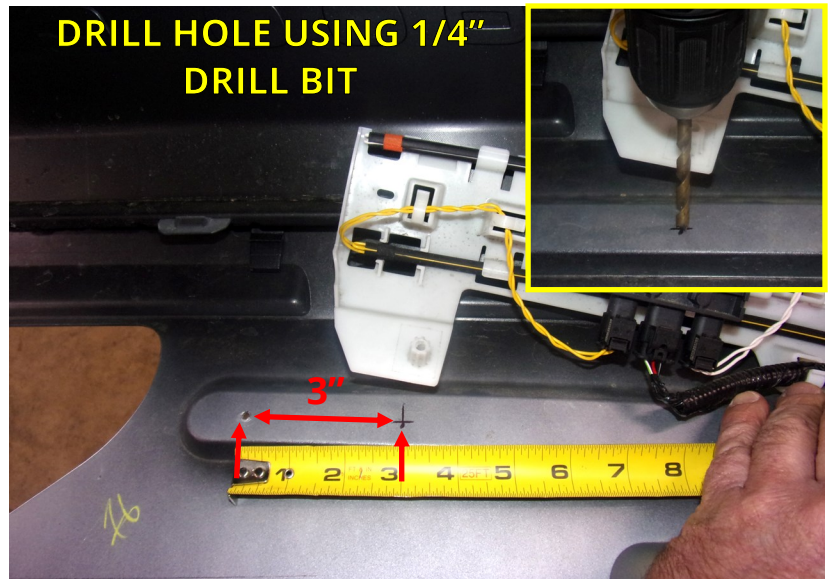

DREMEL TOOL



FILE

31. Place a ruler or straight edge over the fascia and align it with the edge of the cutout as shown. Using the straight edge draw a line about 7-3/4" long. Draw another line parallel to the first 4" away between the edge of the cutout and the plastic kick wand holder. Draw a line, following the edge of the kick wand holder and connect to the end of the first drawn line. Remove kick wand holder and cut out the marked area of the fascia. Smooth the cut with a file.

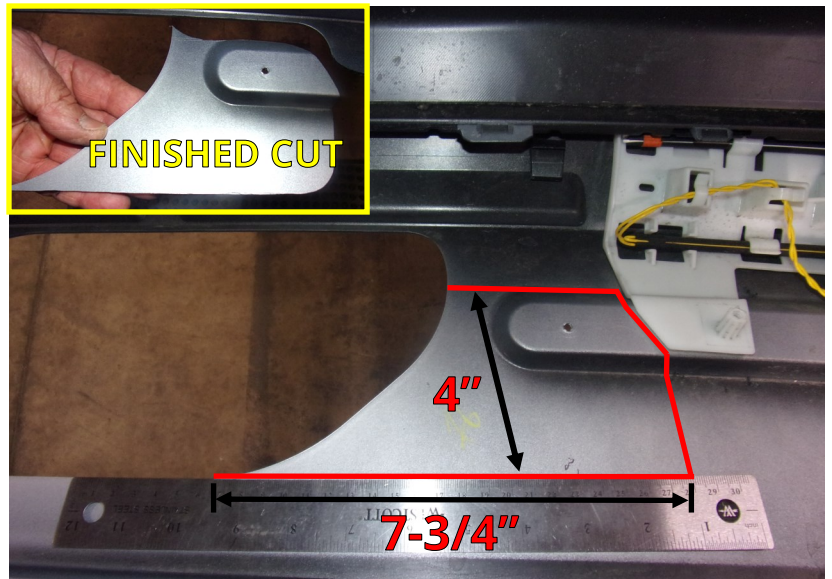

T30 TORX

32. Attach the double sided tape to the bottom of the kick wand holder in the area shown. Align the kick wand holder screw hole with the drilled hole and replace the screw. Then attach the double sided tape to the fascia. Secure excess wire coming from the kick wand holder with a cable tie.

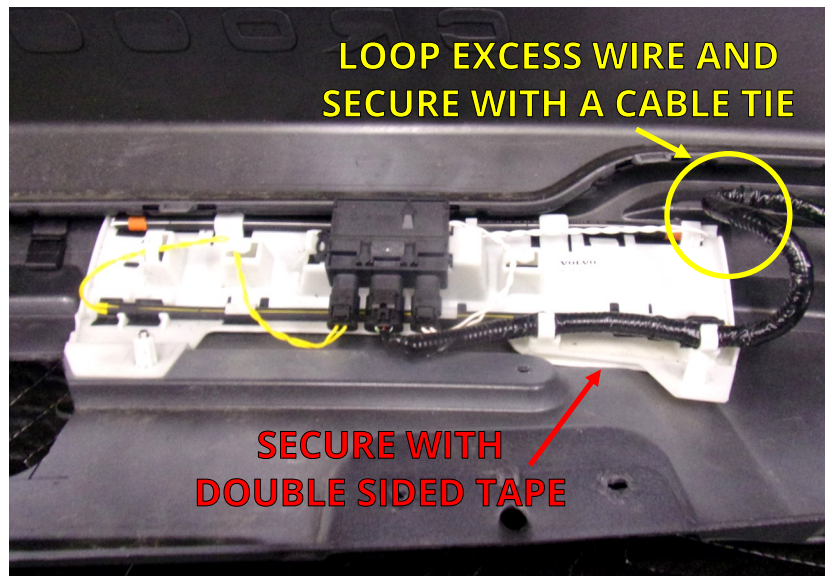

## REINSTALL VEHICLE COMPONENTS

33. Reattach and secure the fascia and other vehicle components in reverse order. Refer to Steps 1-6 and 11-16.

**NOTICE: Remember to plug in the sensor plugs in Step 6 before reinstalling the fascia.**

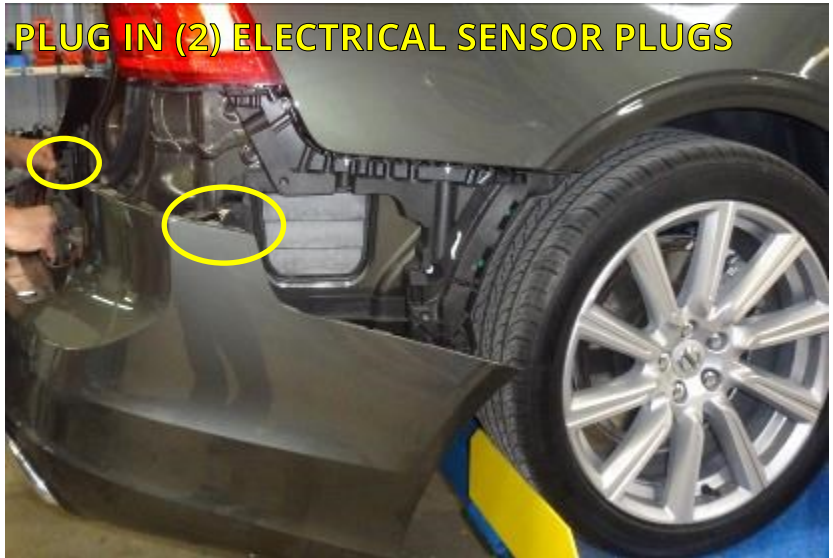

## TEST 7-WAY HARNESS WIRING, PROGRAMMING MUST BE COMPLETED BEFORE TESTING.



MULTIMETER

- Start by connecting the multimeter negative probe to the ground blade on the 7-way receptacle.
- Next, connect the multimeter positive probe to the power blade on the 7-way receptacle and check for 12 volts.
- Once that is confirmed, move the positive probe to the left turn blade on the 7-way receptacle and check for 12 volts when the vehicle left turn blinker is active. You should see it pulse.
- Next, move the positive probe to the right turn blade and check for 12 volts when the right turn blinker is active. You should see it pulse.
- Next, move the positive probe to the marker/taillights. With the vehicle lights on you should see 12 volts constant.
- Lastly, with the brake depressed, move the positive probe to the left turn blade where you should see 12 volts constant. Move the probe to the right turn blade where you should also see 12 volts constant.

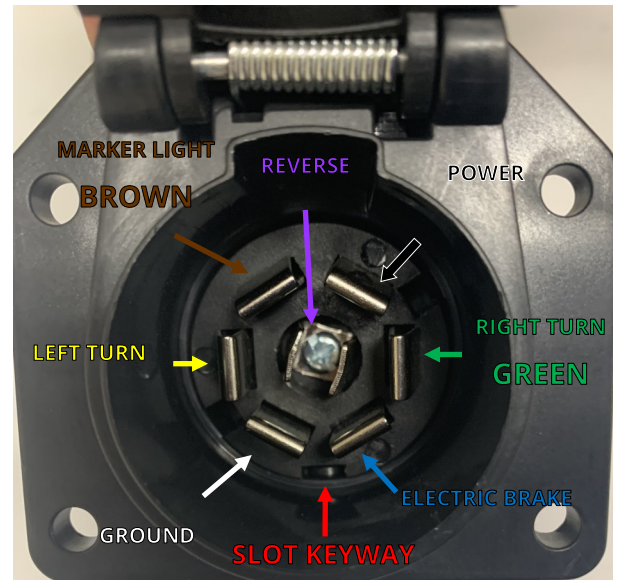

**NOTICE: Most Active harness installations will require programming before testing can be completed. Testing Active wiring harness installations with a multimeter or LED tester may not work. Some vehicles may need to "sense" the current being used by the plug to function. After programming is complete, use an incandescent light testing device or trailer to test in these specific cases.**

## FINAL VEHICLE EXAMINATION

34. Examine the body panels to ensure that they are in a pre-installation condition. Test the electronic functions of the vehicle. Correct any inconsistencies.
35. Ensure that hitch components work properly.
  - **Verify that the lock works correctly.** Push in the safety lock on the latch block then unlock with key. The lock should slide back out with the key when unlocked.
  - **Verify that each accessory can be installed correctly.** Use the following steps to install and remove each accessory that will be used with the hitch. (*Rack Receiver* and *Ball Mount* if purchased.)
    1. Prepare latching mechanism. Turn handle clockwise if needed.
    2. Firmly insert "post" of accessory into latch block until handle releases indicating that the accessory is latched.
    3. Push in the safety locking pin until it fully engages. The locking pin prevents the handle from turning when pushed in, and confirms that the block is securely latched onto the accessory. The safety locking pin will not depress if the accessory is not fully latched.
    4. Use key to release safety locking pin.
    5. While holding on to the accessory, rotate handle clockwise to release and remove the accessory.
  - **Verify that no part of the accessories come into contact with the body of the vehicle.**

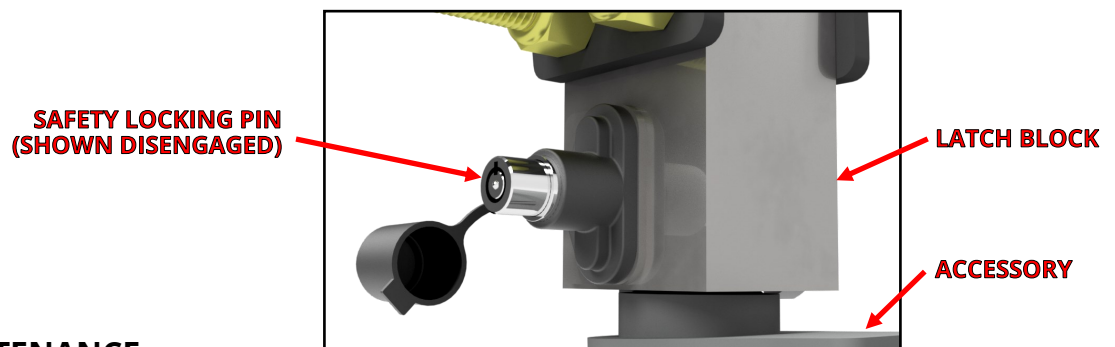

## PRODUCT USE AND MAINTENANCE

**NOTICE: If the hitch is being installed by a professional, the installer is responsible for training the end user in the use and maintenance of the product.**

- **Accessory installation procedure:**
  1. Prepare latching mechanism. Turn handle clockwise if needed.
  2. Firmly insert "post" of accessory into latch block until handle spins counter-clockwise indicating that the accessory is latched.
  3. Always depress the safety locking pin and check that it has fully engaged.
- **Never use any accessory with the safety lock disengaged.** Until the safety locking pin is engaged, the handle is able to turn. A fully engaged safety locking pin is confirmation that the accessory is properly latched into the latch block.
- **Never use the rack receiver for towing.** The rack receiver accessory is only to be used with payload carrying products, such as bike racks or luggage racks.
- **Before each use, give the post of the accessory a light coating of lithium based grease.**
- **Before each use, inspect the hitch to ensure that all bolted connections are secure and that no cracks or damage are present.** Do not tow with the hitch if cracks or damage outside of normal wear is found.
- **Remove the Stealth accessories from the latch block after each use.** Do not leave accessories plugged in for extended periods of time.

**PROGRAMMING VOLVO TRAILER CONTROL UNITS FOR  
VOLVO V 90 CROSS COUNTRY**

**\*SAVE THIS PAGE AND PRESENT TO VOLVO PROGRAMMING STAFF\***

1. Must use OBD2 connector **9513108B** with an ethernet cable.
2. Install control module, fuse and ground per instructions.
3. Connect to vehicle to programming computer.
4. Go to **Software tab** and **New hardware tab** and see if software is available, if not continue to Step #5
5. Go to **Information Tab**
6. Click on **Installation instructions, accessories.**
7. Click on **Group #8** "BODY AND INTERIOR", then **Group #89** "MISCELLANEOUS", then **Group #892** "TOWING AND RECOVERY UNIT", then click "TOW BAR HITCH".
8. Scroll to almost the end and click on the software part number **31435638**
9. This will move the software to your cart, and you will perform the download as normal