



HITCH INSTALLATION INSTRUCTIONS

MAKE: YEARS: MODEL/TRIM:
 MERCEDES 2010 - 2016 E-CLASS WAGON (S212 CHASSIS)

www.stealthhitches.com 833-694-4824

RACK RECEIVER KIT#: **SHR32011**

COMPATIBLE WITH TOW KIT: **SHT25002**

2" RACK RECEIVER MAXIMUM PAYLOAD: 350 LBS
MAXIMUM TOW RATING: 3500 LBS
MAXIMUM TONGUE WEIGHT: 350 LBS

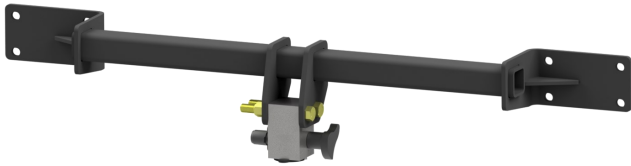

UNDER VEHICLE TRIMMING:

HEAT SHIELD: **NO**
 FASCIA: **YES (SOME MODELS)**
 GRAVEL GUARD TRIMMING: **NO**



READ ALL INSTRUCTION WARNINGS AND LABELS



NO WELDING, METAL DRILLING OR VISIBLE TRIMMING REQUIRED

PARTS SUPPLIED WITH RACK RECEIVER KIT:

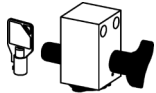

LATCH BLOCK & KEYS



(2) BOLTS
5/8"-11 x 5"



(2) 5/8" NYLOCK NUTS



2" RACK RECEIVER



(8) 7/16" SERRATED FLANGE NUTS



(8) 7/16" - 14 x 1-1/2" BOLTS



MERCEDES (8) 7/16" FLAT WASHERS



(5) 8" CABLE TIE

TOOLS REQUIRED:



15/16", 5/8", 8mm, 10mm, & 16mm OPEN END WRENCHES & 15/16" SOCKETS

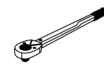

TORQUE WRENCH

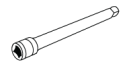

SOCKET EXTENSION



SAFETY GLASSES



RATCHET



FLASHLIGHT



T25 & T40 TORX



PLASTIC PRY TOOLS



90 DEGREE PICK



10 mm HOLLOW NUT DRIVER



5/8" & 16mm RATCHET WRENCHES



PRY BAR



DREMEL TOOL



FILE



DRILL & 1/4" BIT

ADDITIONAL PARTS FOR TOW KIT:



BALL MOUNT 7" RISE, SHORT



CHAIN HOOKS



2" BALL

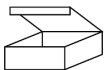

PASSIVE WIRING KIT BOX

ADDITIONAL TOOLS FOR TOW KIT:



MULTIMETER



STRIPPER/CRIMPING TOOL



3/8" BIT



PHILLIPS HEAD SCREWDRIVER



PLIERS



SILICONE



11/16" SOCKET

RACK RECEIVER INSTALLATION: USE STEPS 1-17 & 29-34
TOW KIT INSTALLATION: USE STEPS 1-34

<THESE INSTRUCTIONS MUST BE GIVEN TO THE END USER>

NOTICE: Installation of Stealth products may or may not require the addition of a wiring harness to the vehicle.









- The Rack Receiver only product does not require adding a wiring harness.
- The Rack Receiver plus Tow Kit requires the addition of a "Passive" wiring harness to the vehicle. The passive harness "reads" the output of the vehicle's lights and translates the signals to the trailer without being connected to the vehicle computer.

INSTALLATION NOTE: In most instances, these instructions will only outline disassembly of vehicle components. Re-installation of components will require the installer to retain vehicle hardware and work through disassembly instructions in reverse order. When installation is complete, double check that all vehicle components have been replaced and are secured.

IMPORTANT SAFETY NOTICE FOR STEALTH HITCH INSTALLERS AND CUSTOMERS.

Read all installation and operating instructions along with all labels before installing or using this product. Do not perform any installation or towing procedures without fully understanding the correct tools and actions for all steps. Call for support if needed.

WARNING Failure to comply with the safety information in these instructions could result in serious injury or death.

-  Do not modify this product in any manner. Doing so could alter its integrity and lead to a loss of attachment between the trailer and the tow vehicle.
-  Adding Stealth hitch components to the chassis of any vehicle can be hazardous. There is potential for unexpected combustion of fuel, electric shock, burns, shifting or falling of unstable vehicle, damage to vehicle, injury from tool usage and many other hazards. This installation must be completed by someone who is aware of the hazards involved. This person must be knowledgeable of proper safety procedures for a vehicle modification of this nature, and for usage of the equipment required to perform the installation.
-  Without proper knowledge, towing can be a dangerous activity. Understand all the risks involved with towing before proceeding. For information on towing safety, see "**The Trailer Handbook: A Guide to Understanding Trailer and Towing Safety**" from the National Association of Trailer Manufacturers, www.NATM.com and your trailer and tow vehicle manufacturer's owner's manual.
-  Do not exceed tow or tongue rating of coupler, tow or tongue rating of hitch, or tow or weight ratings of tow vehicle or trailer. See vehicle and trailer manufacturer information for ratings. Exceeding these ratings may cause damage to towing components or loss of attachment between the trailer and vehicle.
-  While installation is being performed, check for signs of damage or excessive corrosion. Do not install hitch components over vehicle parts that are broken or have compromised structural integrity.
-  This product was designed to fit vehicles in their original, "as manufactured" condition. Compatibility with vehicles having replacement parts, or other modifications is not guaranteed. Inspect vehicle for modifications before installation of this product.
-  Some accessories, like the rack receiver, are not rated for towing. Do not use any accessories without proper knowledge of their use.
-  A visual inspection of the hitch should be performed before each use. Regularly check that all connections are secure, including those that secure the hitch to the vehicle. Check for cracks or damage to the hitch. Do not use the hitch if cracks or damage outside of normal wear is found. Using a hitch that has unsecure connections and/or cracks or damage could result in damage to the tow vehicle, trailer, towing components and loss of attachment between the tow vehicle and trailer.
-  Stealth hitches are not compatible with any weight distribution or sway control products. Adding additional products to the trailer or chassis which modifies the function of the Stealth hitch may cause hitch failure.

NOTICE: Installation of hitch requires removal of vehicle parts and interaction with vehicular electronics. Before installation, check the condition of body panels and note any locations where panels are not flush. Check the electronic functions of the vehicle, such as: headlights, taillights, turn signals, cameras, backup sensors, Parking Distance Controller (PDC), foot activated cargo access, etc. It is the responsibility of the installer to restore the fit and function of the vehicle

GAIN ACCESS TO MOUNTING AREA



90 DEGREE PICK

1. Open the vehicle cargo area. Use a 90 degree pick to remove (2) plastic rivets from the floor panel. Remove floor panel.



2. Remove the rear access panels from both sides of the cargo area.



10mm SOCKET

3. On the rear wall of the cargo area locate and remove (2) plastic nuts from the threshold panel. Pull threshold upward to remove.



GAIN ACCESS TO MOUNTING AREA CONTINUED



4. Locate (2) nuts inside the rear wall of the cargo area. Use a hollow nut driver to remove the nuts.



5. Locate and remove (3) nuts securing the rear taillight. Squeeze the plug to disconnect the taillight wiring.



6. Remove the taillight by sliding taillight rearward. Repeat Steps 5-6 on other side of vehicle.



GAIN ACCESS TO MOUNTING AREA CONTINUED



90 DEGREE PICK



10mm SOCKET

7. Inside the rear wheel well, behind the tire, locate the (2) push rivets which are holding the wheel well liner (yellow arrows). Remove these push rivets.
8. Fold the flexible liner back toward the tire. Behind the liner locate and remove (1) screw (green arrow). Repeat Steps 9-10 on other side of vehicle.



T25 TORX



10mm SOCKET

9. Underneath the rear of the vehicle, remove (4) screws using a Torx. Use a socket to remove (2) screws from the bottom of the fascia.



PLASTIC PRY TOOLS

10. The rear fascia is clipped to the vehicle body above and behind the wheel wells. Pull outward on the top front of the rear fascia to expose a clip in the seam. With a plastic pry tool, push down on the exposed clip to disconnect. Continue to pull outward on the fascia and disconnect clips as they are exposed until all clips are released. Repeat on other side of vehicle.



GAIN ACCESS TO MOUNTING AREA CONTINUED

11. This step requires a partner. Pull the fascia rearward enough to access the grommet connected to the electrical sensor plug. Remove the grommet.

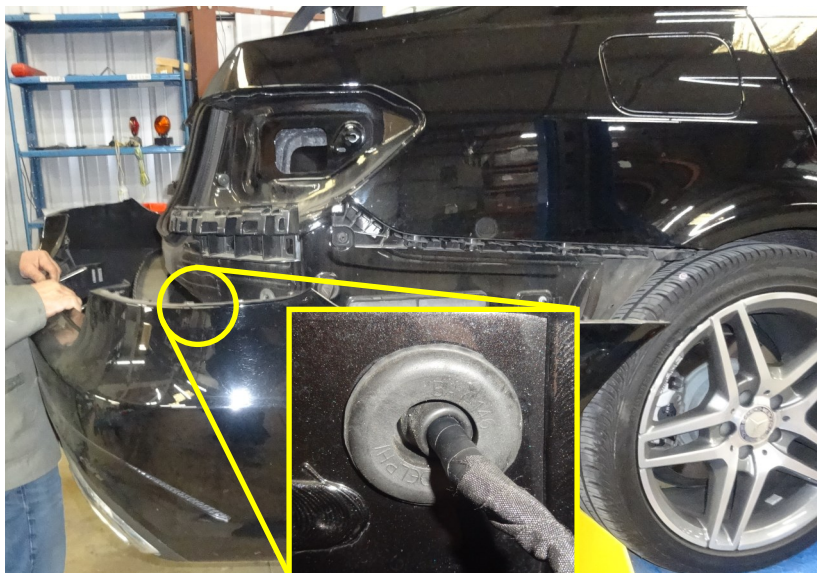

12. Unplug the electrical sensor plug that is part of a harness connected to the vehicle fascia. Remove the fascia completely.

NOTE: If the vehicle has a kick wand option unplug two electrical sensor plugs.

NOTICE: Carefully remove the fascia and place on a blanket or pad.

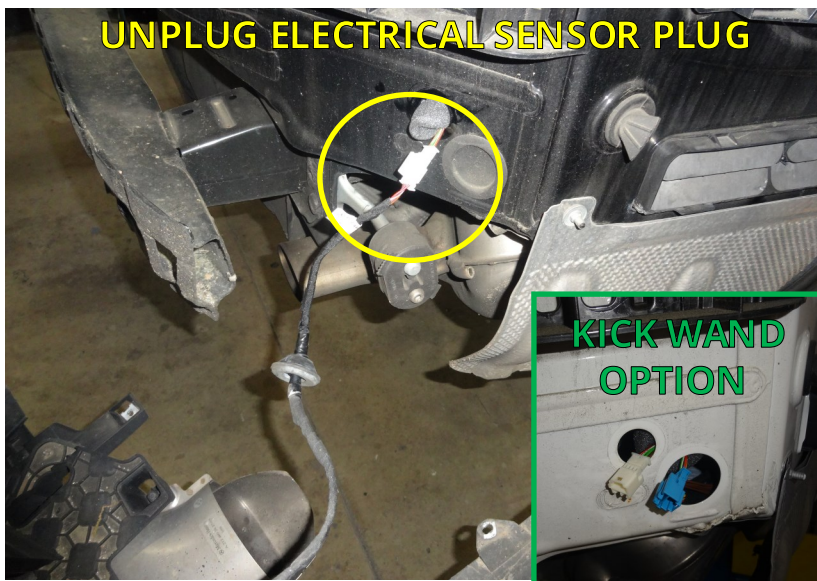

16mm
SOCKET

13. Inside the rear cargo area, locate and remove (4) nuts securing the factory reinforcement beam.

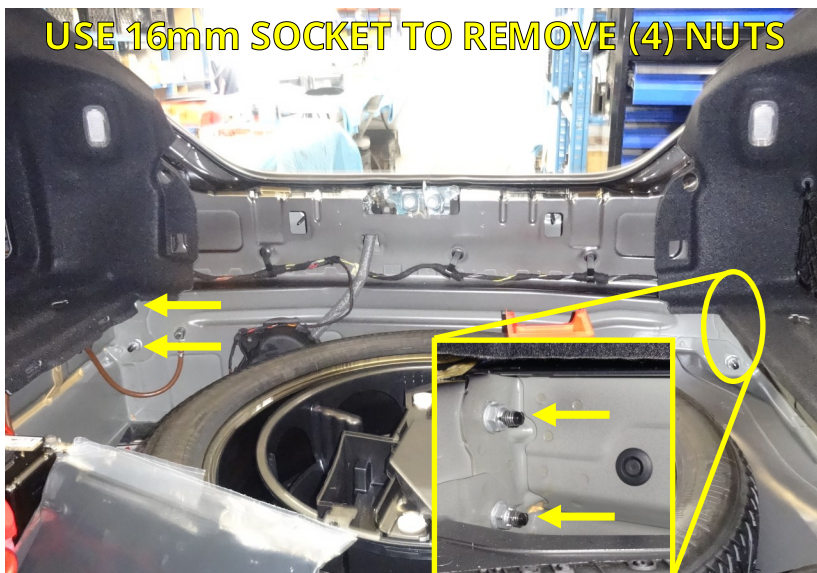

GAIN ACCESS TO MOUNTING AREA CONTINUED



PRY BAR

14. Locate the exhaust bracket under the rear of the vehicle. Use a pry bar to remove the top rubber isolator.

NOTE: Spray lubricant on the connection point to ease removal.

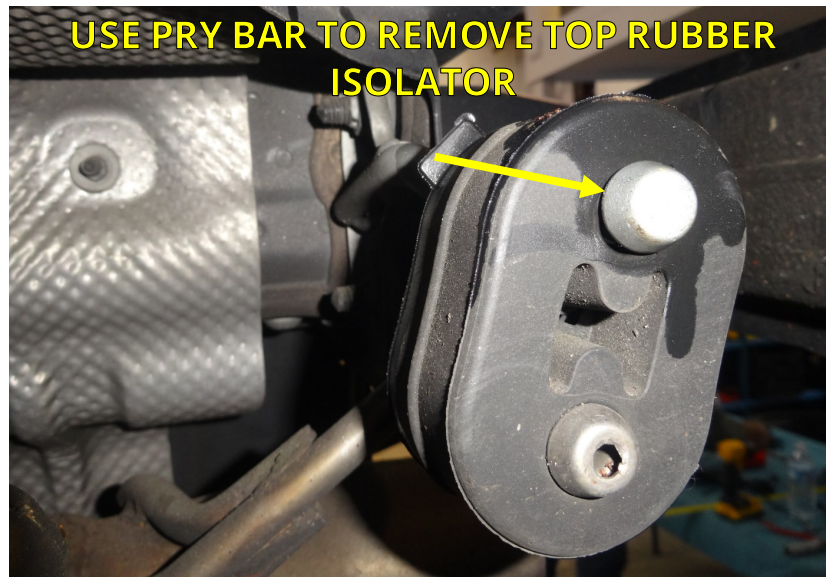

16mm
RATCHET WRENCH



16mm
SOCKET

15. Remove (4) nuts securing the factory reinforcement beam to the vehicle (2) per side. Remove and discard the factory reinforcement beam.

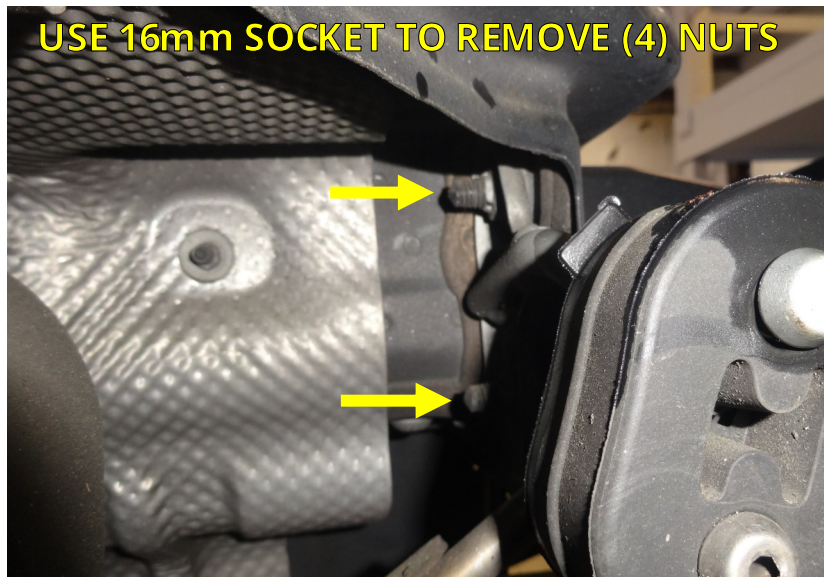

INSTALL STEALTH HITCH FRAME



5/8"
SOCKET



11/16"
SOCKET



5/8"
RATCHET WRENCH



TORQUE
WRENCH

16. Install the Stealth hitch frame onto the vehicle. Use the (8) supplied 7/16" bolts, washers, and nuts. Center the hitch frame before tightening. Use a torque wrench to tighten each nut to 65 ft.-lbs.

USE 5/8" & 11/16" SOCKETS TO INSTALL HITCH (8) 7/16" BOLTS & FLAT WASHERS

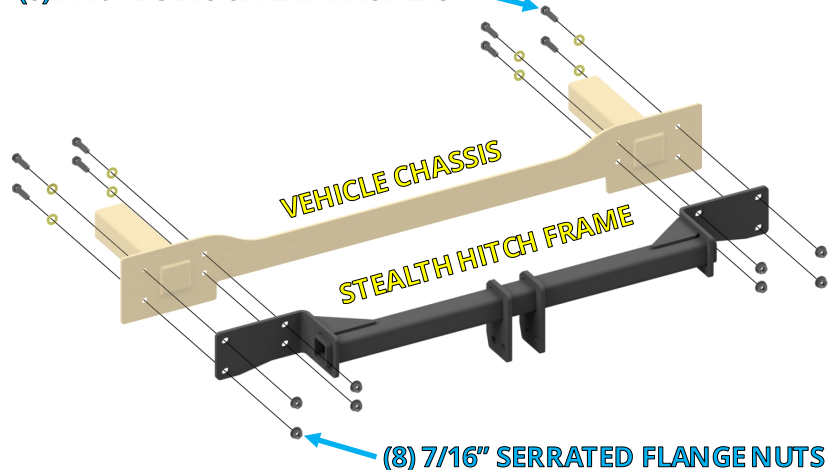

MOUNT LATCH BLOCK



15/16"
SOCKET



15/16" OPEN
END WRENCH

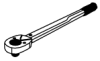

TORQUE
WRENCH

17. Installation of the latch block varies depending on which kit you are installing.

- **Rack Receiver Kit:** Install the latch block with (2) 5/8"-11 x 5" bolts and (2) 5/8" nylock nuts. Tighten each bolt to 150 ft.-lbs.
- **Tow Kit:** Install the latch block, and (2) chain hooks (2) 5/8"-11 x 5" bolts and (2) 5/8" nylock nuts. Tighten each bolt to 150 ft.-lbs.

NOTICE: Keys are packaged within the latch block, remove keys and store in safe location.

RACK RECEIVER KIT INSTALL



TOW KIT INSTALL

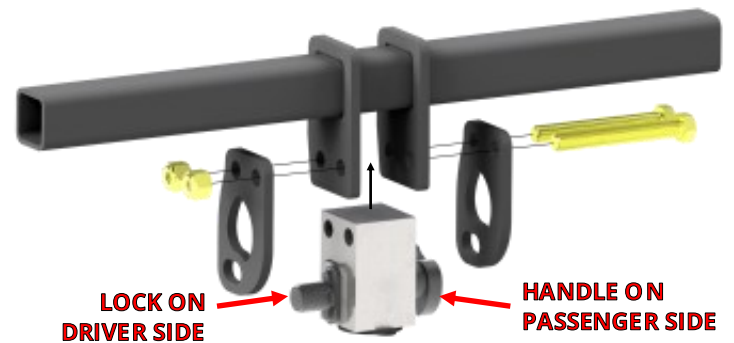

**IF INSTALLING A RACK RECEIVER KIT, SKIP TO STEP 29.
IF INSTALLING A TOW KIT, CONTINUE TO STEP 18.**

INSTALL PASSIVE WIRING KIT

#	DESCRIPTION	QTY
1	4-WAY CONNECTOR HARNESS	1
2	CONTROL MODULE	1
3	4-WAY CONNECTOR COVER	1
4	CABLE TIE - 8"	4
5	CABLE TIE - 14"	2
6	MAGNETIC CABLE HOLDER	1
7	M8 SERRATED FLANGE NUT	1
8	FORK TERMINAL	1
9	ADHESIVE FOAM STRIP	2
10	BUTT CONNECTOR (RED)	4
11	CLAMP-ON CONNECTORS	4

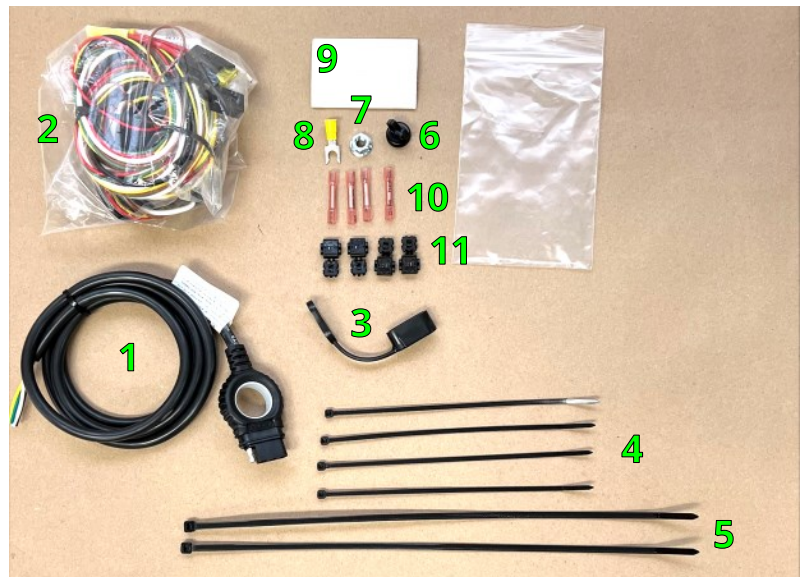

18. Locate the wiring kit box. Review the contents of the box against the list above to check for missing components. The passive wiring kit uses a control module to manage the functions of the trailer lighting. The module has an **"input"** side that receives power from the vehicle's battery and signals from the vehicle's taillights. The **"output"** side of the module delivers this information to the 4-way plug. The control module is connected to the vehicle's battery and taillight wiring as outlined in the next steps.

NOTICE: Do not allow electrical system to become disconnected from power or ground. Doing so may interrupt electrical systems.

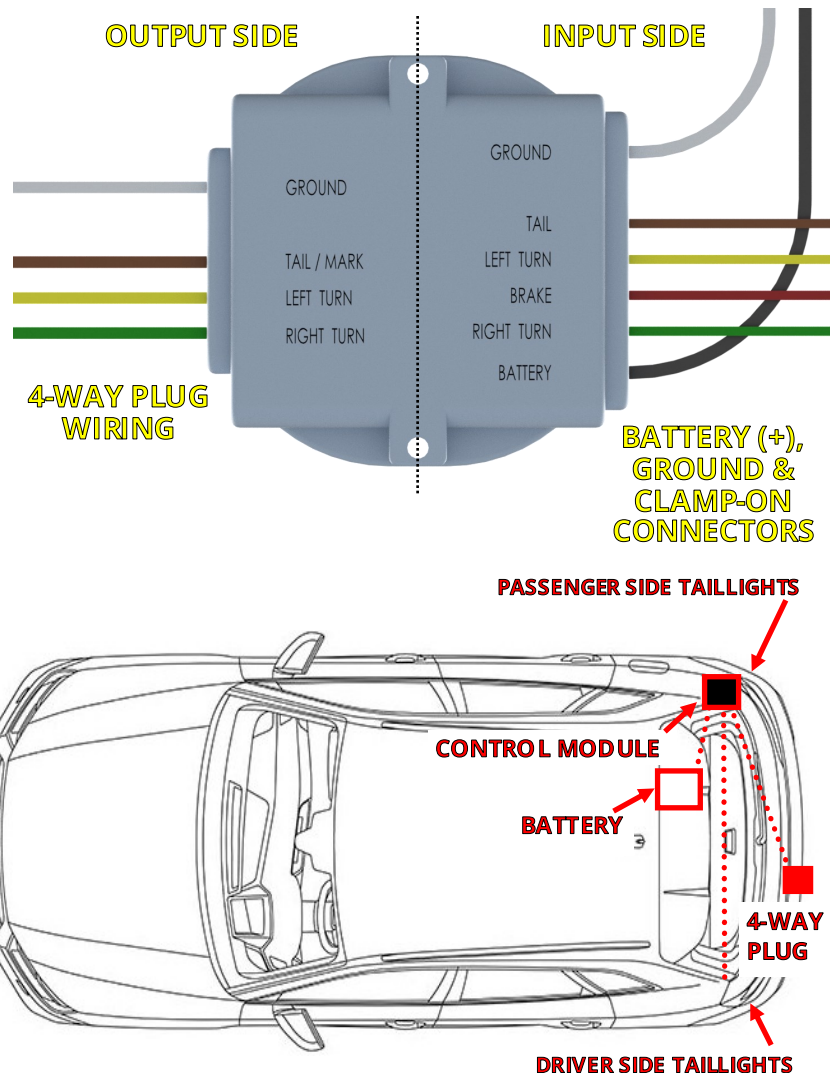

INSTALL WIRING KIT CONTINUED



DRILL &
3/8" BIT

19. Place the control module in the passenger side cargo compartment, behind the side panel. Locate the indicated rubber grommet on the rear passenger side of the vehicle. Drill a 3/8" hole in grommet. Retrieve the 4-way connector harness. Thread the end of the wires into the vehicle through the hole in the grommet.

NOTE: *If the vehicle is equipped with a kick wand, wiring will be present in the grommet. Drill the hole for the wiring and Pass the tow kit wiring next to the existing wiring.*



STRIPPER/
CRIMPING
TOOL

20. Locate the tail of the 4-way connector wire and the output side wires of the control module. Attach each similar color wire to each other using a red butt connector and crimping tool.

NOTICE (OPTIONAL): *The butt connectors are heat shrink connectors. Apply heat to waterproof the connectors after crimping.*

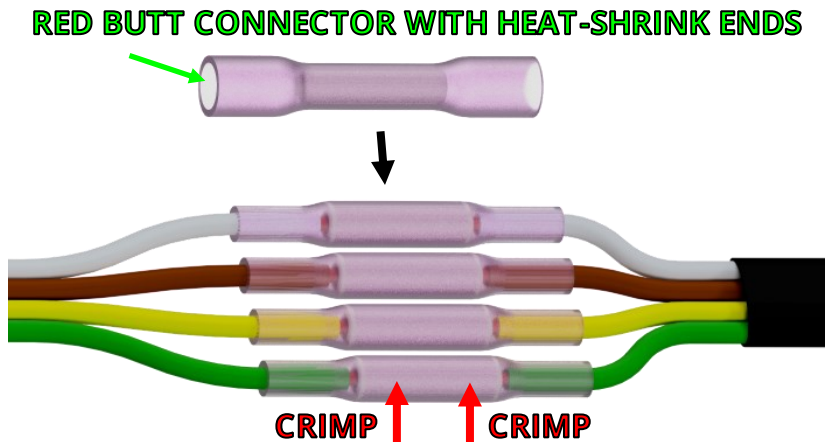

MATCH THE WIRE COLORS AND CRIMP EACH WIRE INTO THE SIDE OF EACH BUTT CONNECTOR. APPLY HEAT TO WATERPROOF AFTER CRIMPING

21. Secure harness to Stealth hitch frame with cable ties. Maintain an 18" loop from the cable tie to the 4-way plug. Add the magnetic cable holder and secure to the harness close to the 4-way plug, with a cable tie.

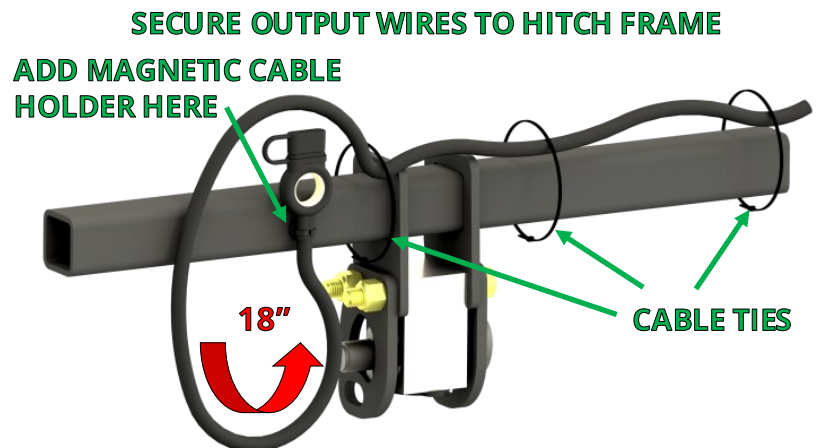

INSTALL WIRING KIT CONTINUED



MULTIMETER



PLIERS

22. The wires on the input side of the module need to be attached to the vehicle wiring. Inside the passenger side cargo compartment locate the indicated part of the vehicle wiring harness. Use clamp-on connectors to connect the brown and green wires to wires behind taillight. (As shown in reference table below.)

NOTE: Vehicle may have different wire colors than those shown. Verify circuits (wire colors) with multimeter.



MULTIMETER



PLIERS

23. Use an existing vehicle wire harness as a guide to route the yellow input wire to the driver side of the vehicle. Locate the indicated part of the vehicle wiring harness. Remove the tape to gain access to taillight wires. Use a clamp-on connector to connect the yellow wire to the left turn signal wire behind the taillight. (As shown in reference table below.)



CLAMP-ON CONNECTOR COLOR REFERENCE TABLE

SIGNAL INPUT WIRES			POWER & GROUND WIRES		
FUNCTION	HARNESS	VEHICLE			
LEFT TURN	YELLOW	GRAY/BLACK	12V+ (POWER)	BLACK	BATTERY (+)
RIGHT TURN	GREEN	GREEN/RED	GROUND	WHITE	GROUND STUD
MARKER	BROWN	BLUE	NOTICE: Do not connect the red brake wire. This vehicle does not utilize a separate brake circuit. The brake signal is sent down the left and right turn circuits simultaneously.		
BRAKE	RED	NOT USED			

NOTE: If two colors are listed, the first color is the dominant color.

INSTALL WIRING KIT CONTINUED



10mm
SOCKET

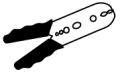

STRIPPER/
CRIMPING
TOOL

24. Locate the ground stud in the passenger side cargo area. Trim white ground wire so it will reach the stud without excess wire. Crimp supplied fork terminal to the ground wire with a crimping tool. Loosen the ground stud and secure the fork to the stud.

NOTICE: Loosen ground stud just enough to install fork terminal, so vehicle wiring does not lose ground.

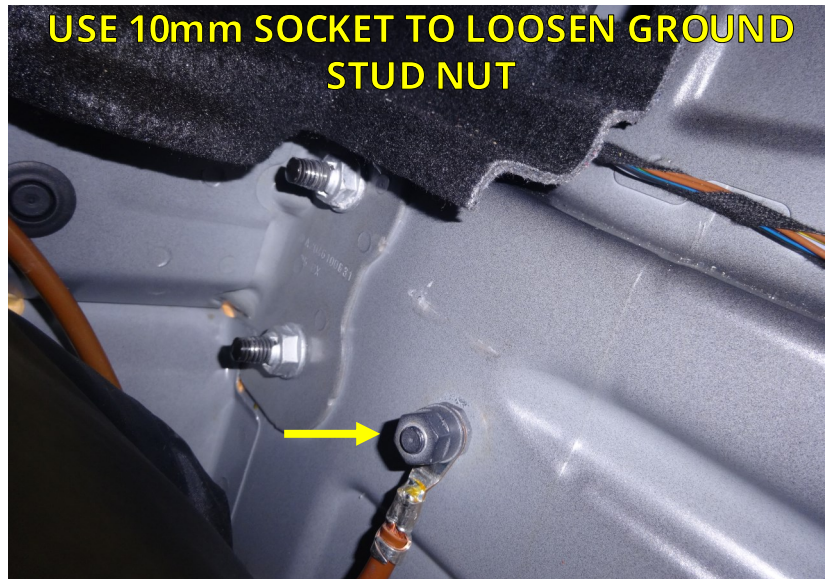

10mm
SOCKET

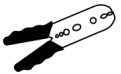

STRIPPER/
CRIMPING
TOOL

25. Locate the fuse holder supplied in the wiring kit box. Remove the fuse from fuse holder. Crimp the fuse lead to power wire and connect to the positive battery terminal (+).



MULTIMETER



SILICONE

26. Reinstall the 20 Amp fuse in the harness fuse holder located near the power supply.

27. Test the 4-way plug using a multimeter or connect the plug to a trailer and verify that the lights and brakes work correctly.

NOTE: Taillights will need to be temporarily plugged in during testing.

28. Secure all wires and wiring components. Use silicone to waterproof the grommet. Use the remaining cable ties to secure wiring so that it is not loose and will not interfere with replacement of the fascia. Wiring should not be visible once the vehicle is reassembled. Use the provided adhesive foam strips to secure the control module to an inside body panel.

CUT ACCESS TO LATCH BLOCK

29. If the vehicle has a kick wand option, the kick wand will need to be moved to allow a clearance hole to be cut in the kick wand holder.

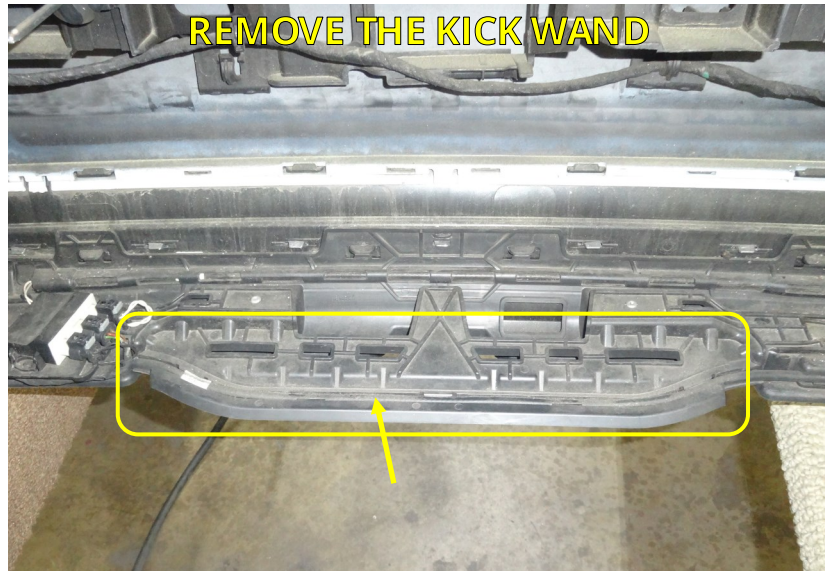

30. Use a Dremel tool to cut out the kick wand holder as shown. Use a file to smooth out the cut.

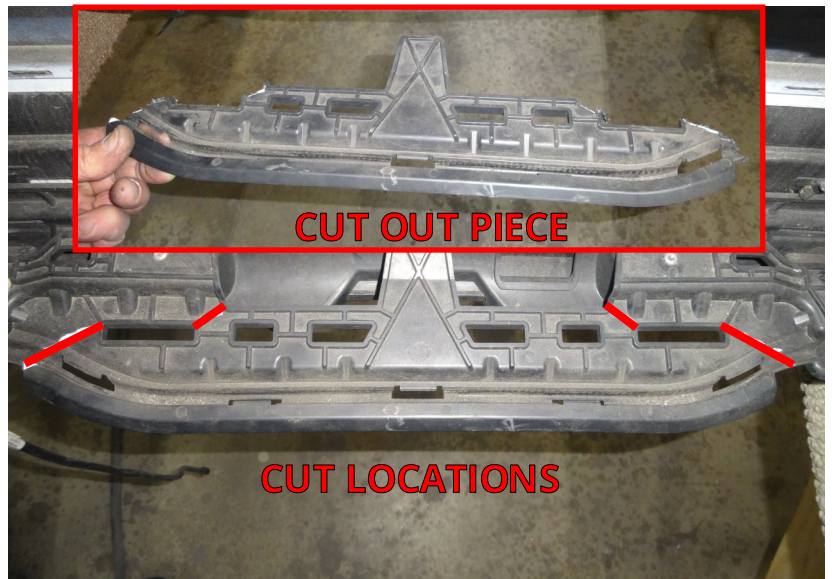

DRILL &
1/4" BIT



(5) 8" CABLE
TIE

31. Drill (5) holes in the kick wand holder in indicated locations. Use cable ties to reattach the kick wand.

NOTE: Use caution when drilling holes through kick wand holder. Do not drill through fascia.



REINSTALL VEHICLE COMPONENTS

32. Reattach and secure the fascia, taillights, and other vehicle components in reverse order. Refer to Steps 1-16.

NOTICE: Remember to reconnect the electrical sensor plug in Step 12 before reinstalling the fascia.



FINAL VEHICLE EXAMINATION

33. Examine the body panels to ensure that they are in a pre-installation condition. Test the electronic functions of the vehicle. Correct any inconsistencies.
34. Ensure that hitch components work properly.
 - **Verify that the lock works correctly.** Push in the safety lock on the latch block then unlock with key. The lock should slide back out with the key when unlocked.
 - **Verify that each accessory can be installed correctly.** Use the following steps to install and remove each accessory that will be used with the hitch. (*Rack Receiver* and *Ball Mount* if purchased.)
 1. Prepare latching mechanism. Turn handle clockwise if needed.
 2. Firmly insert "post" of accessory into latch block until handle releases indicating that the accessory is latched.
 3. Push in the safety locking pin until it fully engages. The locking pin prevents the handle from turning when pushed in, and confirms that the block is securely latched onto the accessory. The safety locking pin will not depress if the accessory is not fully latched.
 4. Use key to release safety locking pin.
 5. While holding on to the accessory, rotate handle clockwise to release and remove the accessory.
 - **Verify that no part of the accessories come into contact with the body of the vehicle.**

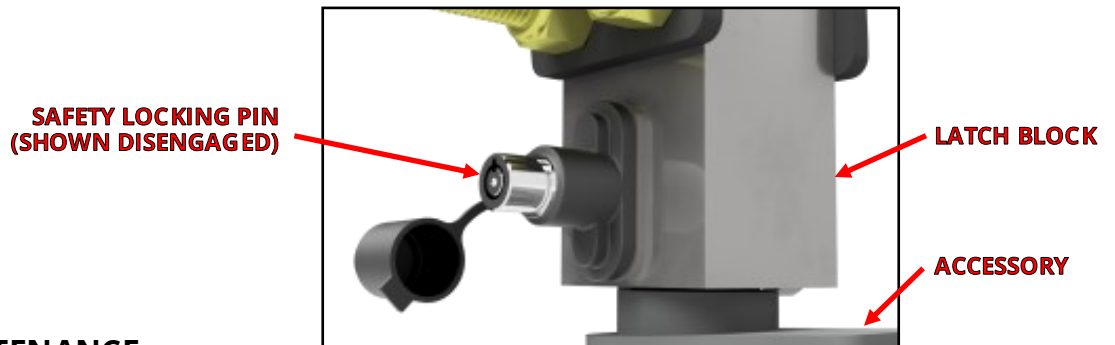

PRODUCT USE AND MAINTENANCE

NOTICE: *If the hitch is being installed by a professional, the installer is responsible for training the end user in the use and maintenance of the product.*

- **Accessory installation procedure:**
 1. Prepare latching mechanism. Turn handle clockwise if needed.
 2. Firmly insert "post" of accessory into latch block until handle spins counter-clockwise indicating that the accessory is latched.
 3. Always depress the safety locking pin and check that it has fully engaged.
- **Never use any accessory with the safety lock disengaged.** Until the safety locking pin is engaged, the handle is able to turn. A fully engaged safety locking pin is confirmation that the accessory is properly latched into the latch block.
- **Never use the rack receiver for towing.** The rack receiver accessory is only to be used with payload carrying products, such as bike racks or luggage racks.
- **Before each use, give the post of the accessory a light coating of lithium based grease.**
- **Before each use, inspect the hitch to ensure that all bolted connections are secure and that no cracks or damage are present.** Do not tow with the hitch if cracks or damage outside of normal wear is found.
- **Remove the Stealth accessories from the latch block after each use.** Do not leave accessories plugged in for extended periods of time.

SHR32011_(pn 2120-32011-2) 08 31 2022