



www.stealthhitches.com

833•694•4824

# HITCH INSTALLATION INSTRUCTIONS

**MAKE:**  
BMW

**YEARS:**  
2020-2022  
2023-2024  
2019-2024  
2019-2022

**MODEL/TRIM:**  
X7 - M50i  
X7 - M60i  
X7 - 40i xDrive & M-Sport  
X7 - 50i xDrive & M-Sport

RACK RECEIVER KIT BOX#: **SHR31033** COMPATIBLE WITH TOW KITS: **SHT25008, SHT25062, SHT25008A, & SHT25062A**

**2" RACK RECEIVER MAXIMUM PAYLOAD:** 600 LBS  
**MAXIMUM TOW RATING:** 8000 LBS  
**MAXIMUM TONGUE WEIGHT:** 800 LBS



## UNDER VEHICLE TRIMMING:

HEAT SHIELD: **NO**  
FASCIA: **NO**  
GRAVEL GUARD TRIMMING: **YES**



**READ ALL INSTRUCTION WARNINGS AND LABELS**



**NO WELDING, METAL DRILLING OR VISIBLE TRIMMING REQUIRED**

## PARTS SUPPLIED WITH RACK RECEIVER KIT:

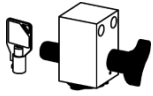

LATCH BLOCK & KEYS



(2) BOLTS  
5/8" - 11 x 5"



(2) 5/8"  
NYLOCK NUTS

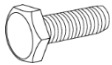

(2) 5/16" X 1"  
BOLTS



(2) 5/16" SERRATED  
FLANGE NUTS



(2) 5/16" FLAT  
WASHERS

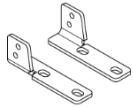

EXHAUST  
BRACKETS

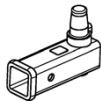

2" RACK  
RECEIVER

## ADDITIONAL PARTS FOR TOW KIT:

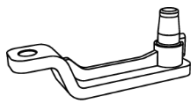

BALL MOUNT  
5" RISE, SHORT



CHAIN HOOKS



2" BALL

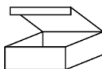

PASSIVE OR **ACTIVE** WIRING  
HARNESS KIT BOX

## TOOLS REQUIRED:



15/16" OPEN  
END WRENCH



18mm DEEP WELL,  
8mm, 10mm, 12mm,  
13mm, 1/2" & 15/16"  
SOCKETS



RATCHET

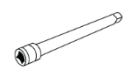

SOCKET  
EXTENSION



T30 TORX



TORQUE  
WRENCH



FLASHLIGHT



PLASTIC  
PRY TOOLS



5/16"  
ALLEN WRENCH



SAFETY GLASSES



DREMEL TOOL



FILE



90 DEGREE  
PICK



PAINTER'S  
TAPE

## ADDITIONAL TOOLS FOR TOW KIT:



DRILL &  
3/8" BIT



STRIPPER/  
CRIMPING  
TOOL



PHILLIPS HEAD  
SCREWDRIVER



FLATHEAD  
SCREWDRIVER



PLIERS



MULTIMETER



SILICONE



T50 TORX



T25 TORX  
SHT25062 &  
SHT25062A  
ONLY



T20 TORX  
SHT25062 ONLY

**RACK RECEIVER INSTALLATION:** USE STEPS 1-22 & 69-76

**2019-2022 PASSIVE TOW KIT INSTALLATION:** USE STEPS 1- 32, 60-61, & 65-76 (**SHT25008**)

**2023-2024 PASSIVE TOW KIT INSTALLATION:** USE STEPS 1-29, 33-44, 60-61, & 65-76 (**SHT25062**)

**2019-2022 ACTIVE TOW KIT INSTALLATION (PRE-WIRED):** USE STEPS 1-27, 45-47, 60-63, & 65-76 (**SHT25008A**)

**2019-2022 ACTIVE TOW KIT INSTALLATION (NOT PRE-WIRED):** USE STEPS 1-27, 45, 48-61, & 64-76 (**SHT25062A**)

**NOTICE: If installing an ACTIVE tow kit, the vehicle must be programmed before trailer lights will function, see notice on Page 3. The active tow kits are not compatible with 2023-2024 model vehicles.**

# <THESE INSTRUCTIONS MUST BE GIVEN TO THE END USER>

NOTICE: Installation of Stealth products may or may not require the addition of a wiring harness to the vehicle.

- The Rack Receiver only product does not require adding a wiring harness.
- The Rack Receiver plus Tow Kit requires the addition a wiring harness that is compatible with the vehicle's wiring. Depending on the vehicle, the harness will be one of two types, "Active" or "Passive." The wiring section of the instructions will indicate which wiring harness style is being used and how to install it.
- The **Active Harness** plugs into the vehicle's wiring so that the vehicle's computer can communicate with the trailer wiring. This allows certain functions such as cameras or backup alarms to continue to operate as designed. Some active harnesses require reprogramming of the vehicle's computer before the trailer wiring is functional. For BMW vehicles that need programming, Stealth provides this service remotely. Refer to the Active Harness section of the instructions to determine if programming is required for this install. ***This programming must be taken into account when planning the timing of the Stealth product install. The remote BMW programming needs to be scheduled approximately 1 week in advance.***
- The **Passive Harness** is independent of the vehicle's computer and communication system. The module of the harness is powered directly from the battery rather than the vehicle's wiring harness. The module monitors the output signals from the vehicle's lights. It then powers and activates the trailer lighting accordingly.

**INSTALLATION NOTE:** In most instances, these instructions will only outline disassembly of vehicle components. Re-installation of components will require the installer to retain vehicle hardware and work through disassembly instructions in reverse order. When installation is complete, double check that all vehicle components have been replaced and are secured.

## IMPORTANT SAFETY NOTICE FOR STEALTH HITCH INSTALLERS AND CUSTOMERS.

Read all installation and operating instructions along with all labels before installing or using this product. Do not perform any installation or towing procedures without fully understanding the correct tools and actions for all steps. Call for support if needed.

### **⚠ WARNING** Failure to comply with the safety information in these instructions could result in serious injury or death.

- ⚠ Do not modify this product in any manner. Doing so could alter its integrity and lead to a loss of attachment between the trailer and the tow vehicle.
- ⚠ Adding Stealth hitch components to the chassis of any vehicle can be hazardous. There is potential for unexpected combustion of fuel, electric shock, burns, shifting or falling of unstable vehicle, damage to vehicle, injury from tool usage and many other hazards. This installation must be completed by someone who is aware of the hazards involved. This person must be knowledgeable of proper safety procedures for a vehicle modification of this nature, and for usage of the equipment required to perform the installation.
- ⚠ Without proper knowledge, towing can be a dangerous activity. Understand all the risks involved with towing before proceeding. For information on towing safety, see "**The Trailer Handbook: A Guide to Understanding Trailer and Towing Safety**" from the National Association of Trailer Manufacturers, [www.NATM.com](http://www.NATM.com) and your trailer and tow vehicle manufacturer's owner's manual.
- ⚠ Do not exceed tow or tongue rating of coupler, tow or tongue rating of hitch, or tow or weight ratings of tow vehicle or trailer. See vehicle and trailer manufacturer information for ratings. Exceeding these ratings may cause damage to towing components or loss of attachment between the trailer and vehicle.
- ⚠ While installation is being performed, check for signs of damage or excessive corrosion. Do not install hitch components over vehicle parts that are broken or have compromised structural integrity.
- ⚠ This product was designed to fit vehicles in their original, "as manufactured" condition. Compatibility with vehicles having replacement parts, or other modifications is not guaranteed. Inspect vehicle for modifications before installation of this product.
- ⚠ Some accessories, like the rack receiver, are not rated for towing. Do not use any accessories without proper knowledge of their use.
- ⚠ A visual inspection of the hitch should be performed before each use. Regularly check that all connections are secure, including those that secure the hitch to the vehicle. Check for cracks or damage to the hitch. Do not use the hitch if cracks or damage outside of normal wear is found. Using a hitch that has unsecure connections and/or cracks or damage could result in damage to the tow vehicle, trailer, towing components and loss of attachment between the tow vehicle and trailer.
- ⚠ Stealth hitches are not compatible with any weight distribution or sway control products. Adding additional products to the trailer or chassis which modifies the function of the Stealth hitch may cause hitch failure.

**NOTICE:** Installation of hitch requires removal of vehicle parts and interaction with vehicular electronics. Before installation, check the condition of body panels and note any locations where panels are not flush. Check the electronic functions of the vehicle, such as: headlights, taillights, turn signals, cameras, backup sensors, Parking Distance Controller (PDC), foot activated cargo access, etc. It is the responsibility of the installer to restore the fit and function of the vehicle.

**NOTICE:** If installing an active wiring harness, your vehicle must be programmed. Arrangements can be made with Code My Car (585-496-4648). Please allow at least a week to make programming arrangements. Programming will require your vehicle to be connected to a computer and an internet connection. **Note:** A programming code is affixed to the control module and the programming cord which will be needed when contacting Code My Car. Additional programming changes may be available at time of programming. Arrangements can be made when contacting Code My Car.

## GAIN ACCESS TO MOUNTING AREA

1. Inside the vehicle cargo area, remove the driver and passenger side access panels as shown.

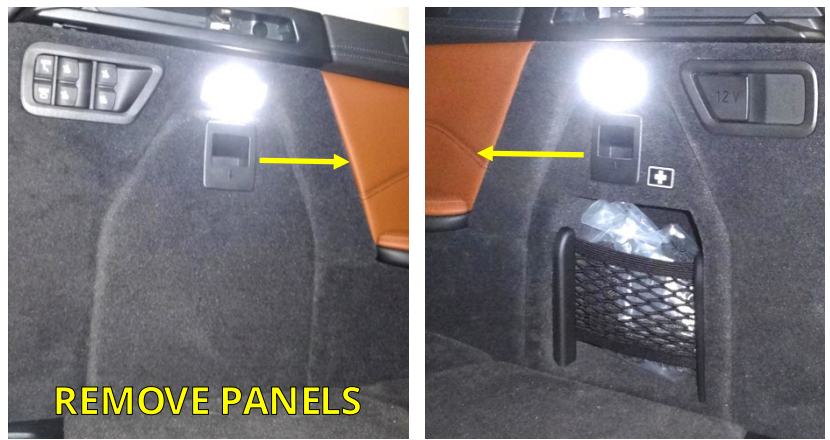

10mm  
SOCKET

- OR -



12mm  
SOCKET

2. In the passenger side access panel, remove the taillight nut with a socket.



3. In the driver side access panel, remove the taillight nut with a socket.

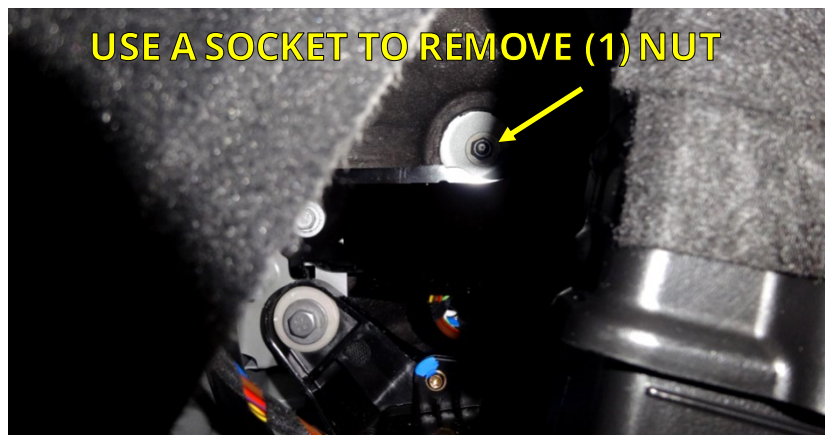

10mm  
SOCKET

- OR -



12mm  
SOCKET



## GAIN ACCESS TO MOUNTING AREA CONTINUED



4. With a pry tool, remove the light cover trim on each side of the vehicle.
5. While holding the taillight in place, remove the screws securing the taillight to the vehicle.



6. With the taillight dislodged, disconnect the light plug by pushing down on the clip and pulling the plug outward. Remove the light. Repeat Steps 5-6 on other side of vehicle.



7. To allow partial removal of the rear wheel well trim, (3) clips will need to be disconnected. Apply outward pressure on wheel well trim. Start with the bottom clip and work up. Push down on clip to disconnect. Use plastic pry tools on hard to reach clips.
8. Behind the rear wheel well trim there are (2) screws holding the fascia. Pull the trim away from vehicle to expose screws. Use a socket to remove screws. Repeat Steps 7-8 on other side of vehicle.

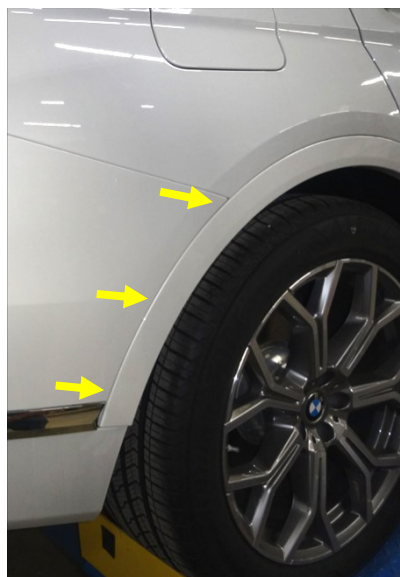

**NOTE:** To protect the trim from being scratched during the removal or replacement, cover it with painter's tape or something similar.



## GAIN ACCESS TO MOUNTING AREA CONTINUED



9. Starting on the side closest to the center of the vehicle, use a plastic pry tool to remove each reflector.



10. A screw, which is holding the fascia, will be exposed when the reflector is removed. Use a socket to remove the screw.



- OR -



11. From underneath the vehicle, use a socket to remove (24) screws from the bottom edge of the fascia and bottom cover plate.



## GAIN ACCESS TO MOUNTING AREA CONTINUED



12. The fascia is clipped to the vehicle body directly behind the wheel wells. Pull outward on the fascia to expose the first clip in the seam. With a plastic pry tool, push down on the exposed clip to disconnect. Continue to pull outward on the fascia and disconnect clips as they are exposed.

Continue applying outward and rearward pressure until all the clips except the four rear center clips are released. Repeat on other side of vehicle.



13. While positioned behind the center of the vehicle, locate the (4) remaining clips holding the fascia. Before disconnecting each clip, put rearward pressure on the fascia. Starting from one side, use an Allen wrench to push down and disconnect each clip.

**NOTE:** Use caution when pulling the fascia rearward. The fascia is still connected to the vehicle by a wire harness.



14. This step requires a partner. Pull the fascia rearward enough to access the PDC sensor plug on the passenger side. Press down on the clips to unplug the PDC sensor plug. In some cases a 90 degree pick tool will be needed to disconnect the sensor plug. Remove the fascia completely.

**NOTICE:** Carefully remove the fascia and place on a blanket or pad.

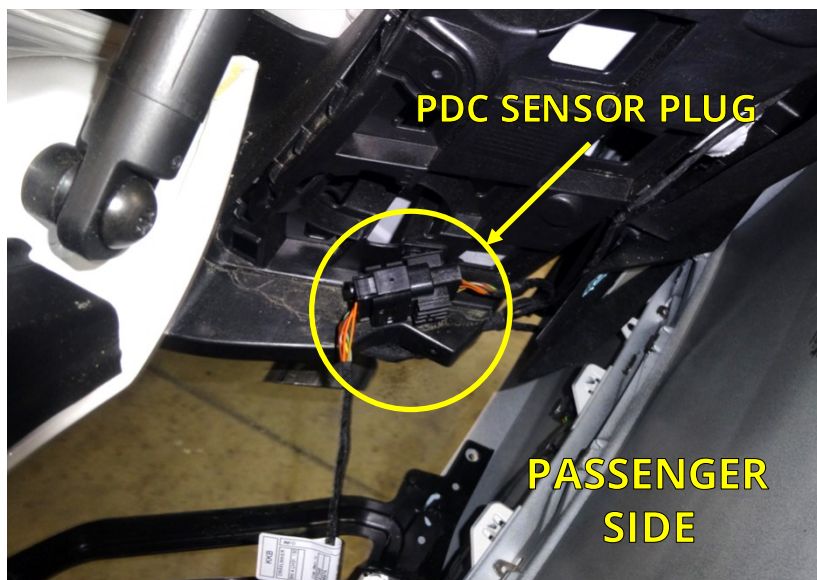



## GAIN ACCESS TO MOUNTING AREA CONTINUED



90 DEGREE PICK



10mm SOCKET

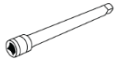

SOCKET EXTENSION

15. Remove two plastic panels that are part of the plastic fascia support on each side. Removing the panels will allow access to the factory nuts securing the factory reinforcement beam. Use a 90 degree pick to remove (2) plastic rivets (yellow arrows), and a socket to remove (1) nut (green arrow).



13mm SOCKET



90 DEGREE PICK

16. Locate the two exhaust brackets under the rear of the vehicle, above the muffler. Use a socket to remove (1) exhaust bracket nut on each side of the vehicle (yellow arrow). On the passenger side remove (1) plastic rivet from factory reinforcement beam, as shown (green arrow).



90 DEGREE PICK



18mm DEEP WELL SOCKET

17. Remove the plastic kick wand panel by removing (5) plastic rivets with a 90 degree pick (yellow arrows). Save (3) plastic rivets for reinstallation. Unplug the wire harness connected to the panel and put aside. Remove the factory reinforcement beam (8) nuts with a socket and save for later reinstallation (green arrows). Discard the factory reinforcement beam.





## GAIN ACCESS TO MOUNTING AREA CONTINUED

18. Locate the spacer beam shown in the image. Remove and discard the beam.

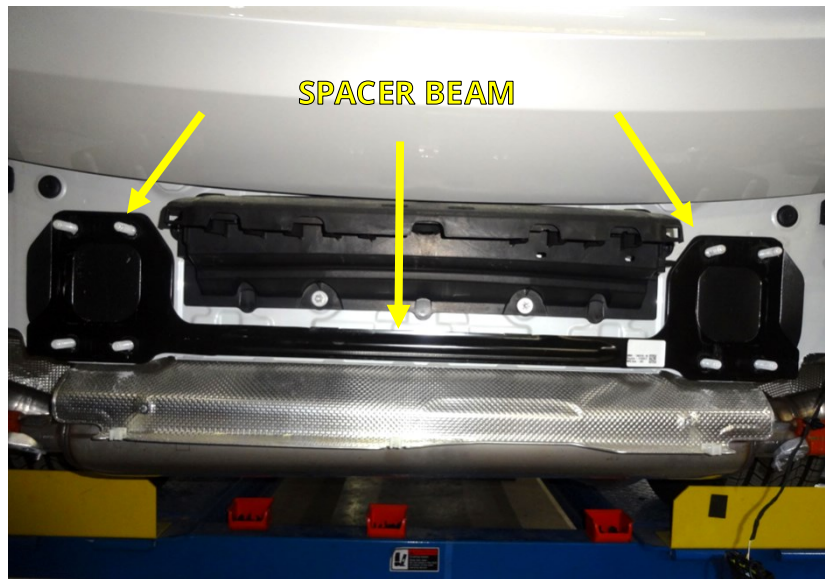

## INSTALL STEALTH HITCH FRAME



19. Install the Stealth hitch frame and the supplied exhaust brackets. (See Diagram.) Center the hitch frame. Use a torque wrench to tighten the factory nuts to 85 ft.-lbs.

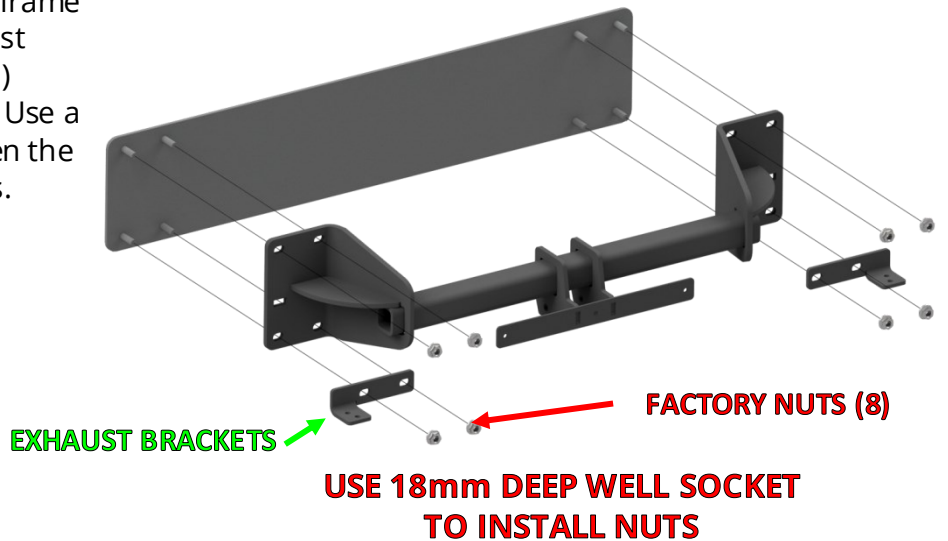

20. Reinstall the two plastic panels that were removed in Step 15.



## INSTALL STEALTH HITCH FRAME CONTINUED



1/2"  
SOCKET

21. Reinstall the exhaust brackets removed in Step 16. Use (2) supplied bolts, washers and nuts.



## MOUNT LATCH BLOCK



15/16"  
SOCKET



15/16" OPEN  
END WRENCH



TORQUE  
WRENCH

22. Installation of the latch block varies depending on which kit you are installing.

- **Rack Receiver Kit:** Install the latch block with (2) 5/8"-11 x 5" bolts and (2) 5/8" nylock nuts. Tighten each bolt to 150 ft.-lbs.
- **Tow Kit:** Retrieve Z-bracket from wiring harness kit box. Install the latch block, (2) chain hooks, and Z-bracket with (2) 5/8"-11 x 5" bolts and (2) 5/8" nylock nuts. Tighten each bolt to 150 ft.-lbs.

**NOTICE:** Keys are packaged within the latch block, remove keys and store in safe location.

### RACK RECEIVER KIT INSTALL



### TOW KIT INSTALL

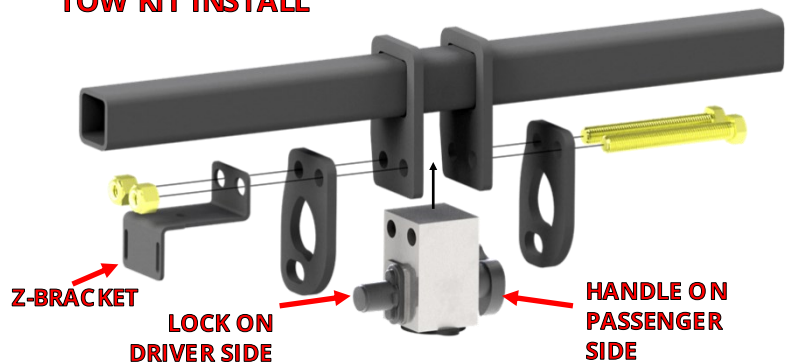

**IF INSTALLING A RACK RECEIVER KIT, SKIP TO STEP 69.  
IF INSTALLING A TOW KIT, CONTINUE TO STEP 23.**

## INSTALL WIRING KIT



23. Locate the wiring kit box. Review the contents of the box against the list below and on the next page to check for missing components.

- **The passive wiring kits** use a control module to manage the functions of the trailer lighting. The module has an “input” side that receives power from the vehicle’s battery and signals from the vehicle’s taillights. The “output” side of the module delivers this information to the 7-way plug, see *passive harness diagram*. The control module is connected to the vehicle’s battery and taillight wiring as outlined in the next steps.
- **The active wiring kits** use a BMW computer control module to manage the functions of the trailer lighting. The module must be “programmed” before it will be functional. The module will connect to the vehicle through an included wire harness. The harness has an “input” side that receives power and signals from the vehicle’s electronic systems. The “output” side of the harness delivers this information to the 7-way plug. The harness and computer module installation are outlined in the next steps.

**NOTICE: Do not allow electrical system to become disconnected from power or ground. Doing so may interrupt electrical systems.**

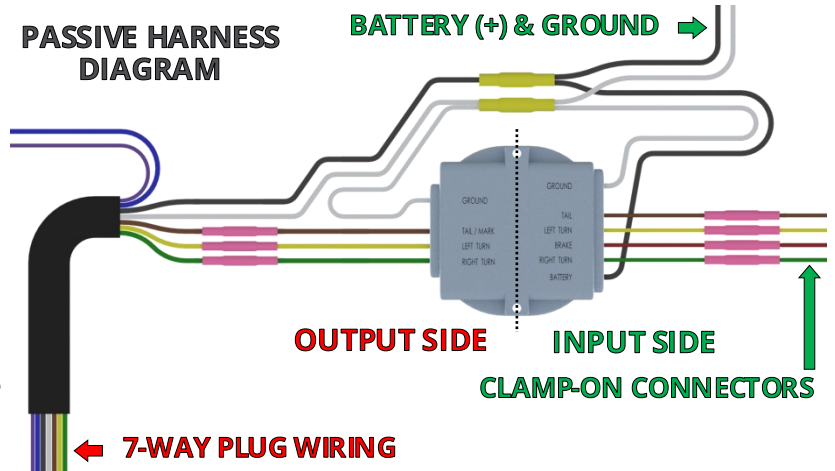

### 2019-2022 PASSIVE WIRING KIT BOX

#	DESCRIPTION	QTY
1	7-WAY WIRING HARNESS	1
	• FUSE HOLDER & FUSE	
	• CONTROL MODULE & WIRES	
2	ADHESIVE FOAM STRIP	2
3	FORK TERMINAL	1
4	CLAMP-ON CONNECTORS	5
5	5/8" LONG PHILLIPS SCREWS	4
6	#10 LOCK NUT	4
7	CABLE TIE - 8"	4
8	CABLE TIE - 14"	3
9	Z-BRACKET	1
10	MOUNTING BRACKET	1
11	7-POLE HOUSING	1
12	7-POLE TO 4-POLE ADAPTER	1

### 2019-2022 PRE-WIRED ACTIVE WIRING KIT BOX



#	DESCRIPTION	QTY
1	WIRING HARNESS	1
2	BMW CONTROL MODULE	1
3	5/8" LONG PHILLIPS SCREWS	4
4	#10 LOCK NUT	4
5	CABLE TIE - 8"	4
6	CABLE TIE - 14"	2
7	Z-BRACKET	1
8	MOUNTING BRACKET	1
9	7-POLE HOUSING	1
10	7-POLE TO 4-POLE ADAPTER	1
11	VEHICLE PROGRAMMING CABLE	1



Kits continued on next page...



## 2019-2022 NOT PRE-WIRED **ACTIVE** WIRING KIT BOX

#	DESCRIPTION	QTY
1	WIRING HARNESS	1
2	BMW CONTROL MODULE	1
3	WIRING HARNESS ADAPTER	1
4	#10 LOCK NUT	4
5	5/8" LONG PHILLIPS SCREWS	4
6	CLAMP-ON CONNECTORS	4
7	CABLE TIE - 8"	4
8	CABLE TIE - 14"	2
9	20 AMP FUSE	1
10	Z-BRACKET	1
11	MOUNTING BRACKET	1
12	7-POLE HOUSING	1
13	7-POLE TO 4-POLE ADAPTER	1
14	VEHICLE PROGRAMMING CABLE	1

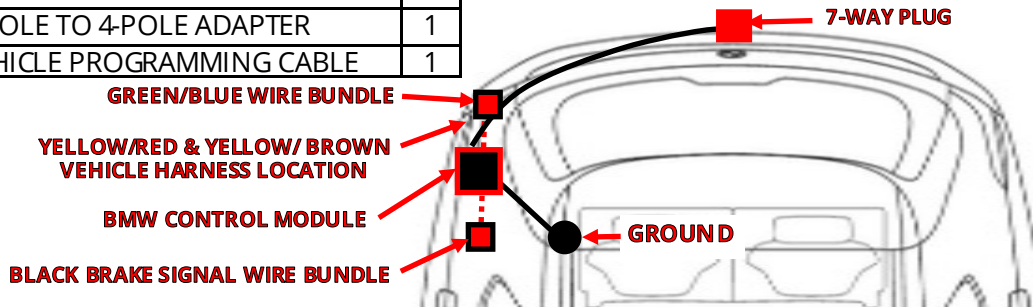
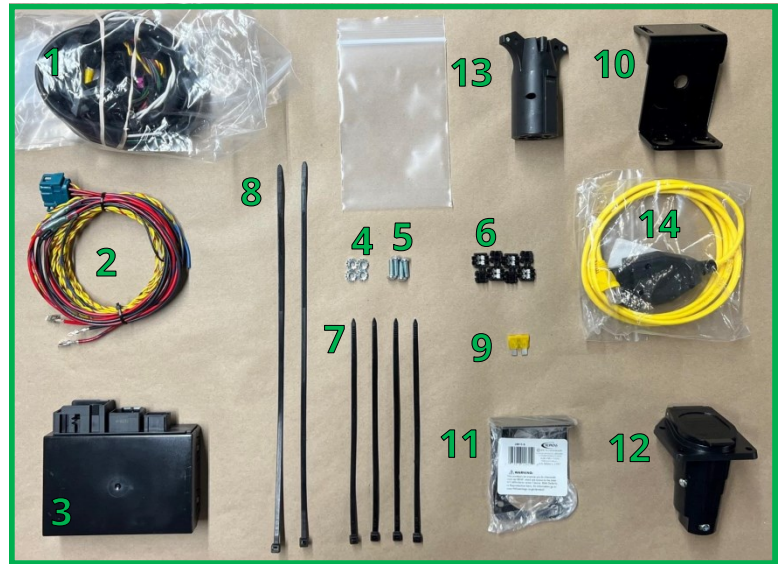

## 2023+ **PASSIVE** WIRING KIT BOX

#	DESCRIPTION	QTY
1	7-WAY WIRING HARNESS <ul style="list-style-type: none"> <li>FUSE HOLDER &amp; FUSE</li> <li>CONTROL MODULE &amp; WIRES</li> </ul>	1
2	ADHESIVE FOAM STRIP	2
3	FORK TERMINAL	1
4	CLAMP-ON CONNECTORS	5
5	5/8" LONG PHILLIPS SCREWS	4
6	#10 LOCK NUT	4
7	BUTT CONNECTOR RED	2
8	CABLE TIE - 8"	6
9	CABLE TIE - 14"	3
10	MOUNTING BRACKET	1
11	Z-BRACKET	1
12	7-POLE HOUSING	1
13	7-POLE TO 4-POLE ADAPTER	1
14	GREEN WIRE BUNDLE - 15'	1
15	YELLOW WIRE BUNDLE - 15'	1

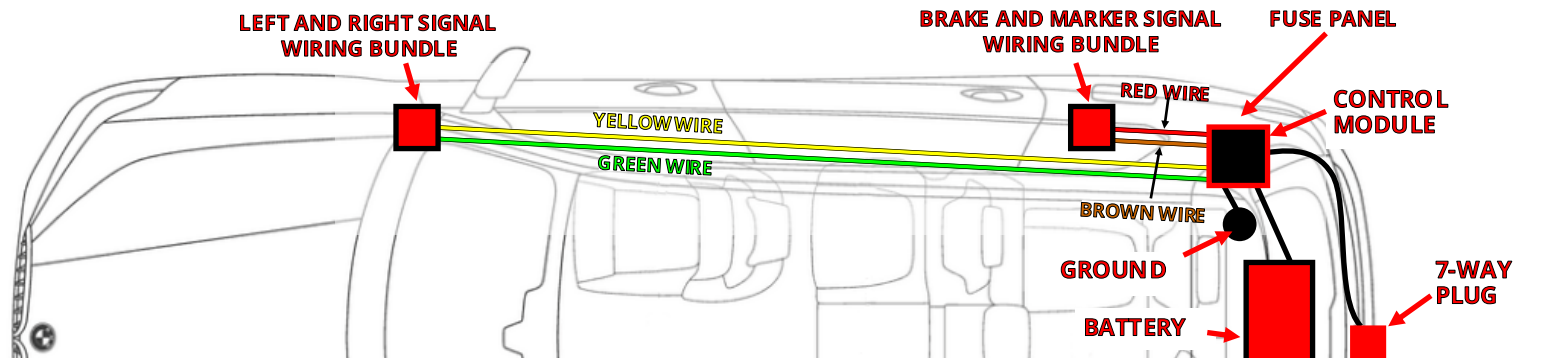



## INSTALL WIRING KIT (ALL VEHICLES)



90 DEGREE PICK



T50 TORX

24. Your vehicle may have one of two battery compartment configurations.

- **If your trunk looks like the top image**, under the rear floor panel remove (8) plastic rivets from battery cover and passenger side tool tray to gain access to the spare tire and battery compartment.
- **If your trunk looks like the bottom three images**, remove the spare tire and the (1) plastic rivet from the rear wall of the trunk. If present use a Torx to remove the spare tire strap. Pull the trunk liner up and out to reveal the battery compartment below.



25. Place the control module (passive install) or the wiring harness (active install) inside the passenger side compartment.



DRILL & 3/8" BIT

26. On the passenger side of the vehicle locate the factory grommet to the right of Stealth hitch frame. Drill a 3/8" hole in the grommet where indicated.

**NOTICE: Check for obstructions on other side of grommet before drilling. Use caution when drilling.**

27. Feed output wires and black sheathing through grommet from inside vehicle to outside of vehicle.



IF INSTALLING A **PASSIVE** TOW KIT, CONTINUE TO STEP 28.  
IF INSTALLING AN **ACTIVE** TOW KIT, SKIP TO STEP 45.



## INSTALL PASSIVE WIRING KIT



10mm  
SOCKET

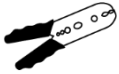

STRIPPER/  
CRIMPING  
TOOL

28. Locate the fork terminal supplied in the wiring kit box. Trim the ground wire so it will reach the ground screw without excess wire. Crimp the fork terminal to the ground wire. Connect the ground wire to the negative battery terminal (-).

29. Locate the fuse holder supplied in the wiring kit box. **Remove the fuse from fuse holder.** Trim the power wire so it will reach the ground screw without excess wire. Crimp fuse lead to power wire. Connect fuse ring terminal to the positive battery terminal (+).

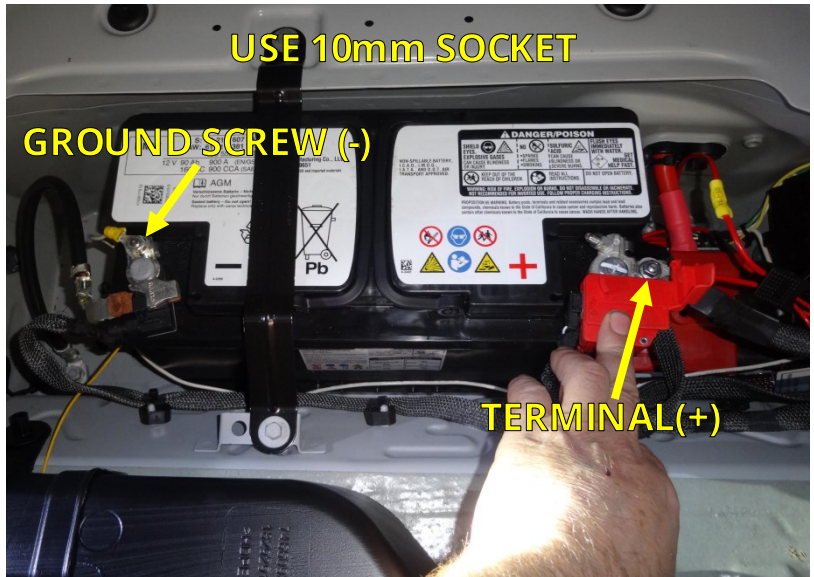

**NOTICE: Loosen battery terminals just enough to install wiring, so vehicle wiring does not lose ground or power.**



**IF INSTALLING A PASSIVE TOW KIT ON A 2019-2022 VEHICLE, CONTINUE TO STEP 30.  
IF INSTALLING A PASSIVE TOW KIT ON A 2023+ VEHICLE, SKIP TO STEP 33.**

30. From the passenger side of the vehicle, route the yellow input wire to the driver side of the vehicle along the threshold using an existing wire harness as a guide.

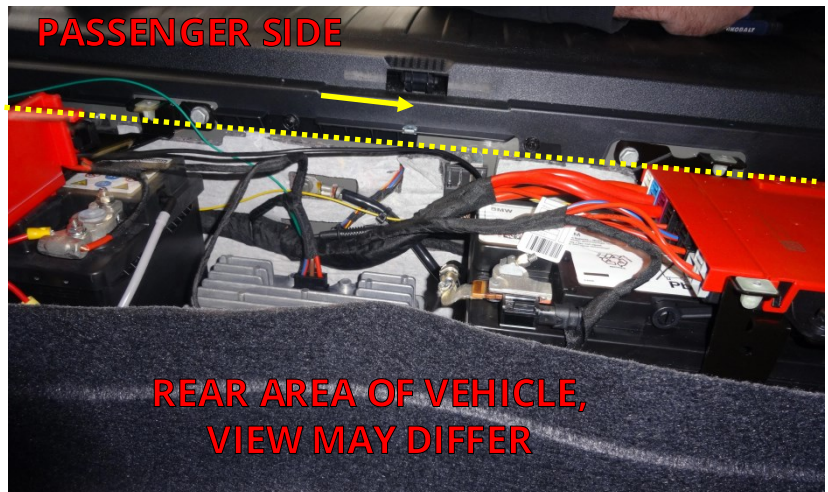

PLIERS



MULTIMETER

31. The wires on the input side of the wiring module need to be attached to the vehicle wiring. On the driver side use a clamp-on connector to clamp the yellow wire to the left turn signal wire, behind taillight. (See reference table on the next page.)

**Note:** Vehicles may have different wire colors than those shown. Verify circuits (wire colors) with multimeter.

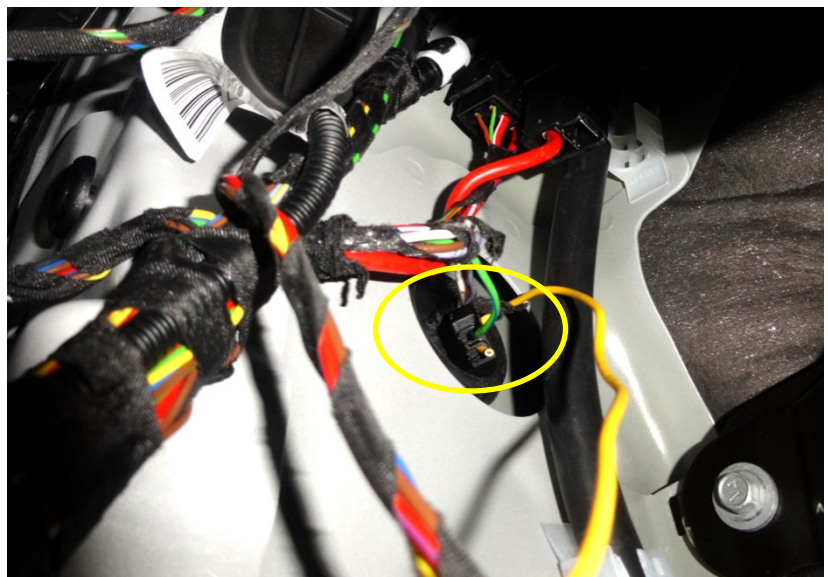



# INSTALL PASSIVE WIRING KIT 2019-2022 VEHICLES CONTINUED



PLIERS







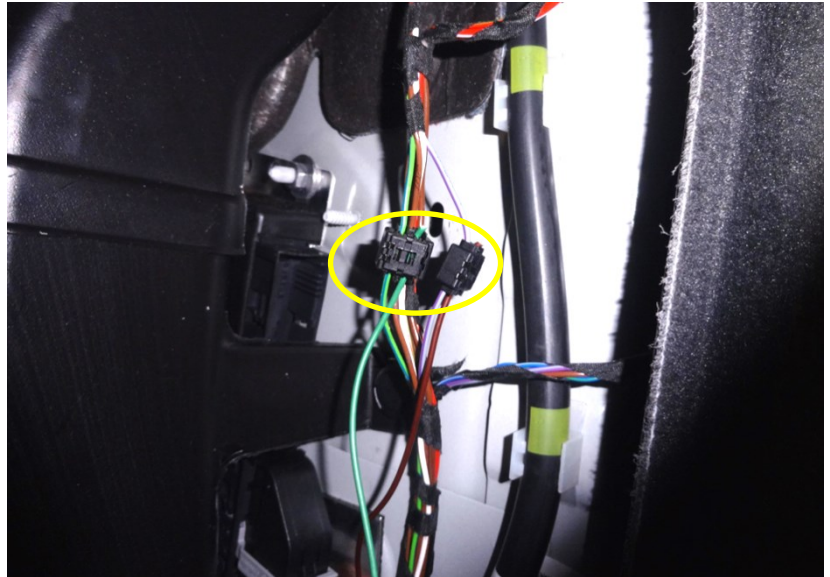





MULTIMETER

32. Inside the passenger side compartment, use clamp-on connectors to connect the green and the brown wires to wires behind taillight. (See reference table below.)



**Skip to Step 60 to continue installation.**

## CLAMP-ON CONNECTOR COLOR REFERENCE TABLE

SIGNAL INPUT WIRES			POWER & GROUND WIRES		
FUNCTION	HARNESS	VEHICLE			
<u>LEFT TURN</u>	 YELLOW	 GREEN/BLUE	<u>12V+ (POWER)</u>	 BLACK	BATTERY (+)
<u>RIGHT TURN</u>	 GREEN	 GREEN/BLUE	<u>GROUND</u>	 WHITE	BATTERY (-) / GROUND STUD
<u>MARKER</u>	 BROWN	 GREY/PURPLE			
<u>BRAKE</u>	 RED	<b><i>Do not connect the red brake wire. This vehicle does not utilize a separate brake circuit. The brake signal is sent down the left and right turn circuits simultaneously.</i></b>			
<u>REVERSE</u>	 PURPLE	For use with trailer reverse lights or to disable the trailer brakes when backing with surge brakes. To connect, isolate vehicle's reverse light circuit and connect the purple wire from the trailer wiring harness to vehicle reverse light circuit. <b><i>Trailers rarely have reverse lights or surge brakes.</i></b>			
<u>ELECTRIC BRAKE</u>	 BLUE	Only used when a hard wired brake controller is mounted inside the vehicle and your trailer has electric brakes. See brake controller instructions for this wire.			

**NOTE: If two colors are listed, the first color is the dominant color.**

## INSTALL PASSIVE WIRING KIT 2023+ VEHICLES

33. The signal wires for the left and right turn signals are located in the front passenger side area of the cabin. Open the passenger side front door. In the area above the foot well, locate and turn two knobs to release the plastic panel shown in the image. Pull the plastic panel down and unplug the light from the panel. Remove the panel from the vehicle.



34. Use a plastic pry tool to remove the plastic door frame cover next to the passenger side seat. Put upward pressure on the cover to disconnect (4) plastic rivets. Lift the cover up and unplug the accent light connector. Remove the plastic panel.



35. Inside the passenger side foot well, use a Torx to remove a plastic screw-rivet securing the passenger side door frame panel. Put inward pressure on the top portion of the panel to disconnect two rivets. Remove the panel.

**NOTE:** The wire bundle referenced in Step 38 with the left and right turn signal wires is located under this panel.

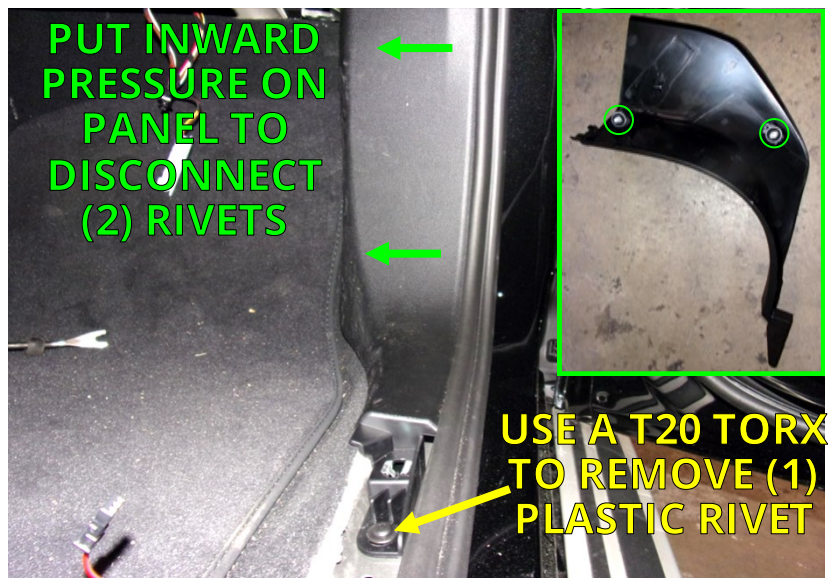



## INSTALL PASSIVE WIRING KIT 2023+ VEHICLES

36. Locate the green and yellow wires inside the wiring kit box. Uncoil the wires. Place the loose wires into the cargo compartment. Route one end of the wires through the passenger side wall panel and underneath the 3rd row seat toward the front of the vehicle.

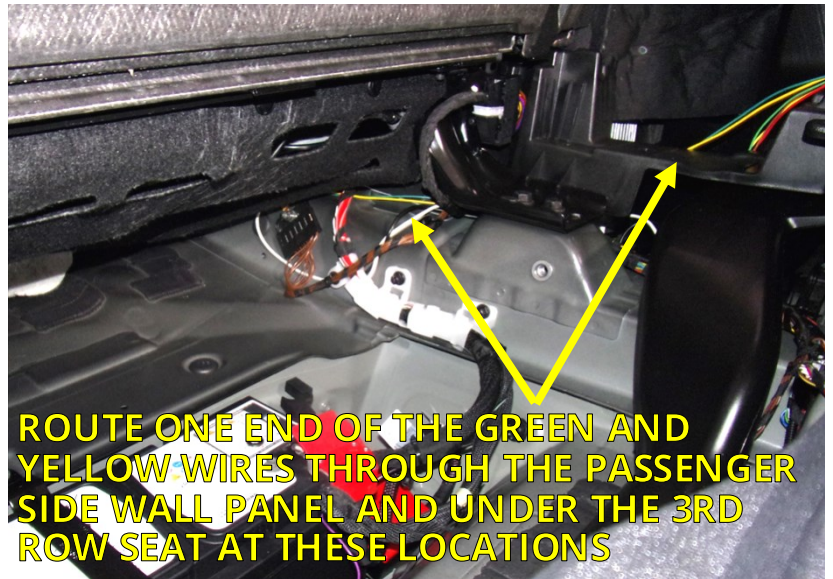

37. Route the green and yellow wires forward, as shown, to the area where the passenger side door panel was removed in Step 35.



PLIERS



MULTIMETER

38. Locate the indicated wire bundle behind the panel removed in step 35. Use clamp-on connectors to connect the yellow and green signal wires to the left and right turn signal wires (see reference table on next page).













**NOTE:** Vehicles may have multiple wires with the same color or different wire colors than those shown. Verify circuits (wire colors) with multimeter.





# INSTALL PASSIVE WIRING KIT 2023+ VEHICLES

## CLAMP-ON CONNECTOR COLOR REFERENCE TABLE

SIGNAL INPUT WIRES			POWER & GROUND WIRES		
FUNCTION	HARNESS	VEHICLE			
<u>LEFT TURN</u>	 YELLOW	 BLUE	<u>12V+ (POWER)</u>	 BLACK	FUSE TERMINAL (+)
<u>RIGHT TURN</u>	 GREEN	 BLUE/YELLOW	<u>GROUND</u>	 WHITE	GROUND NUT
<u>MARKER</u>	 BROWN	 GREY/BROWN			
<u>BRAKE</u>	 RED	 BLACK			
<u>REVERSE</u>	 PURPLE	For use with trailer reverse lights or to disable the trailer brakes when backing with surge brakes. To connect, isolate vehicle's reverse light circuit and connect the purple wire from the trailer wiring harness to vehicle reverse light circuit. <b>Trailers rarely have reverse lights or surge brakes.</b>			
<u>ELECTRIC BRAKE</u>	 BLUE	Only used when a hard wired brake controller is mounted inside the vehicle and your trailer has electric brakes. See brake controller instructions for this wire.			

**NOTE: If two colors are listed, the first color is the dominant color.**



39. With the yellow and green wires connected, tuck the length of green and yellow wire that is visible in the front passenger and rear passenger areas under the trim where possible. No wire should be visible when the removed plastic trim pieces are replaced in a later step.



40. Inside the wall of the passenger side cargo compartment, locate the loose ends of the green and yellow wires and the green and yellow input wires of the control module. Trim the wires to length. Attach each similar color wire to each other using a red butt connector and crimping tool.

**NOTICE (OPTIONAL): The butt connectors are heat shrink connectors. Apply heat to waterproof the connectors after crimping.**

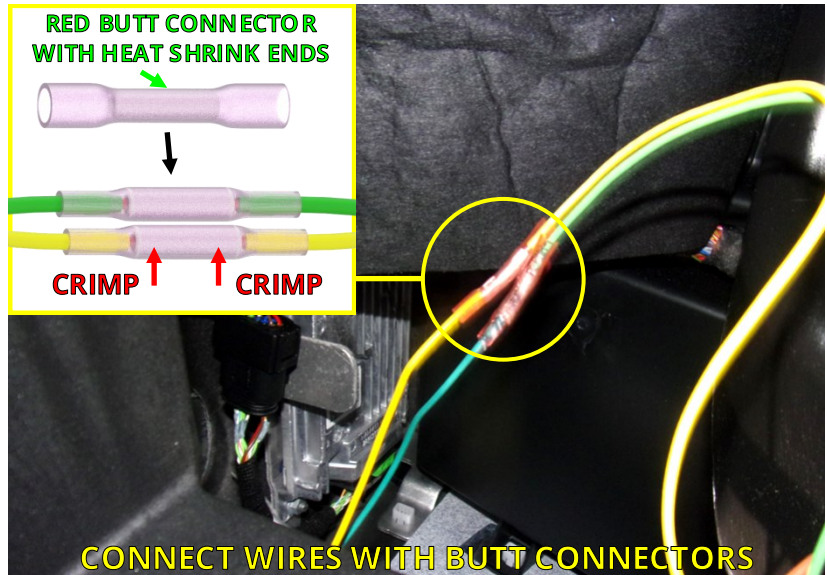

## INSTALL PASSIVE WIRING KIT 2023+ VEHICLES



90 DEGREE PICK



PLASTIC PRY TOOLS



T25 TORX

- OR -



T30 TORX



8mm SOCKET



PLIERS



MULTIMETER

41. To connect the red and brown wires, the passenger side top rear panel needs to be removed. Use a 90 degree pick to open the small plastic cover. Use a Torx to loosen (1) screw. Use a plastic pry tool and use inward pressure to remove the panel.

USE A 90 DEGREE PICK TOOL TO OPEN PLASTIC COVER

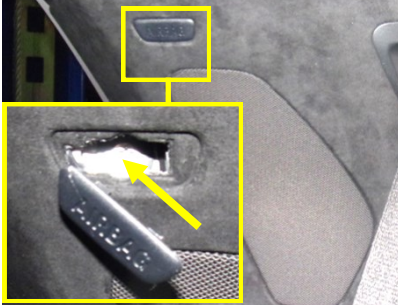

USE A T25 OR T30 TORX TO REMOVE (1) SCREW

USE A PLASTIC PRY TOOL TO REMOVE PASSENGER SIDE TOP REAR PANEL



42. If the harness bundle shown in the next step is not easily accessible, the speaker unit can be partially removed and moved out of the way. Use a socket to remove (3) screws holding the speaker unit.

USE AN 8mm SOCKET TO REMOVE (3) SCREWS



43. Locate the indicated wire bundle. Route the red and brown wires to the wire bundle location. Trim the red and brown wires to length and use clamp-on connectors to connect the red and brown wires to the brake and marker signal wires (see reference table on the previous page).

PROBE WIRES AND ATTACH CLAMP-ON CONNECTORS TO THE BRAKE AND MARKER SIGNAL WIRES

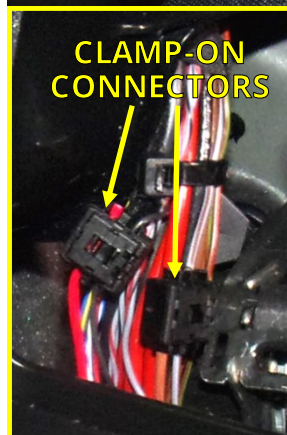

**NOTE:** Vehicles may have multiple wires with the same color or different wire colors than those shown. Verify circuits (wire colors) with multimeter.

44. Use a cable tie to secure the wire bundle so that it will not come into contact with any of the moving parts on the safety belt unit.



Skip to Step 60 to continue installation.



## INSTALL **ACTIVE** WIRING KIT



45. Inside the cargo area locate the tool tray/panel on the passenger side. Use a 90 degree pick tool to remove (3) rivets to gain access to the passenger side compartment. Retrieve the wiring harness and control module from the tow kit box. Place the control module inside the passenger side compartment.

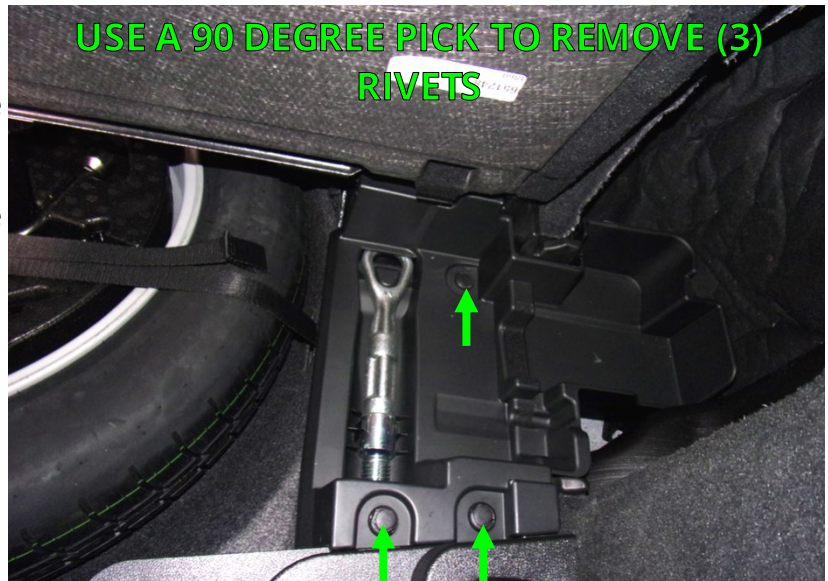

IF INSTALLING AN **ACTIVE** TOW KIT ON A PRE-WIRED VEHICLE, CONTINUE TO STEP 46.  
IF INSTALLING AN **ACTIVE** TOW KIT ON A NOT PRE-WIRED VEHICLE, SKIP TO STEP 48.



46. Locate the ground stud on the rear wall of the cargo area. Use a socket to remove the ground stud nut. Route the active wiring harness ground ring from the passenger side compartment, behind the plastic, to the ground stud as shown in image. Secure the ground ring with the ground stud nut.



**NOTICE: Do not allow components already attached to ground stud to become disconnected and lose ground.**

47. In the active wiring kit box locate the BMW control module. Attach the active wiring harness to the control module. Plug the (24) pin connector into the "A" slot and lock it with the lock clip. Plug the (6) pin connector into the "B" slot, and the (10) pin connector into the "C" slot. Place the control module into the slot shown in the fuse panel.

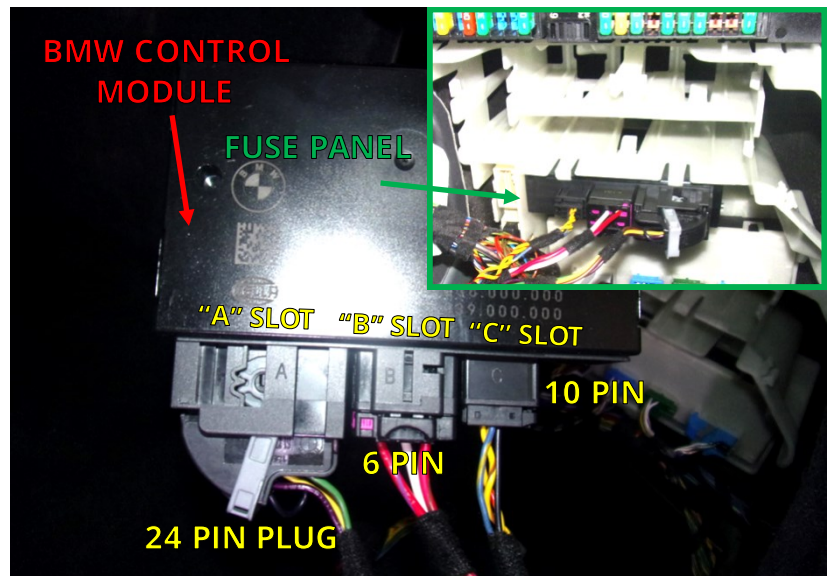

**Skip to Step 60 to continue installation.**



## INSTALL **ACTIVE** WIRING KIT NOT PRE-WIRED VEHICLES



48. Locate the fuse panel in the passenger side compartment. Use (2) plastic pry tools to dislodge the fuse panel from the white plastic housing. Place each pry tool as shown in the image and put downward pressure on each tool to release (2) clips. Slide the fuse panel out of the housing.



49. Carefully pull the fuse panel out of the compartment and turn it over to gain access to the wiring on the back.

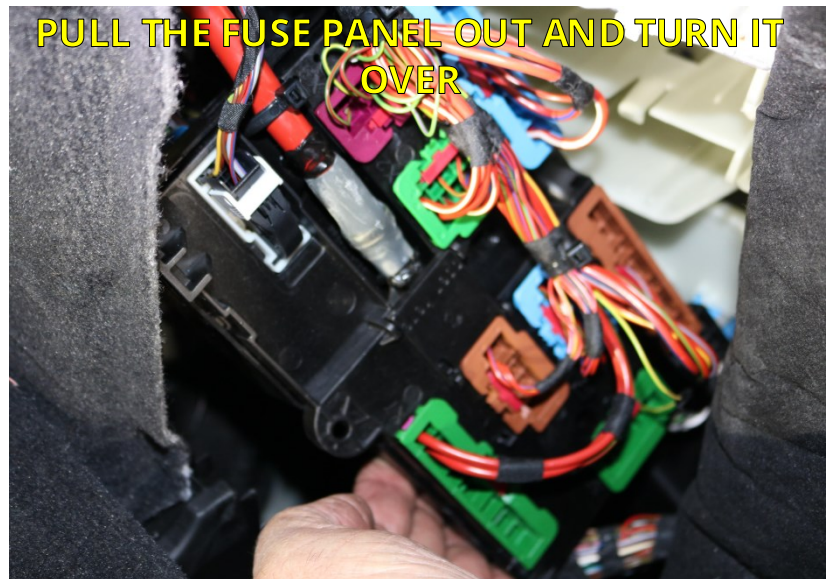



## INSTALL **ACTIVE** WIRING KIT NOT PRE-WIRED VEHICLES

50. Locate the wiring harness adapter located in the tow kit box. Three of the wires have spring clips attached to the end of the wires. These clips are designed to plug into the back of the fuse panel. Use the image below to find the location for each of the wires and carefully insert the spring clips.

- Red/Black: Slot (2) on the indicated brown strip.
- Red/Blue: Slot (3) on same brown strip.
- Black: Into the second slot on the indicated green strip.

**NOTICE:** The spring clip for the black wire can be inserted incorrectly. The clip must be inserted so it will clip on to a fuse blade inserted into the other side of the fuse panel, see the green box and text below.

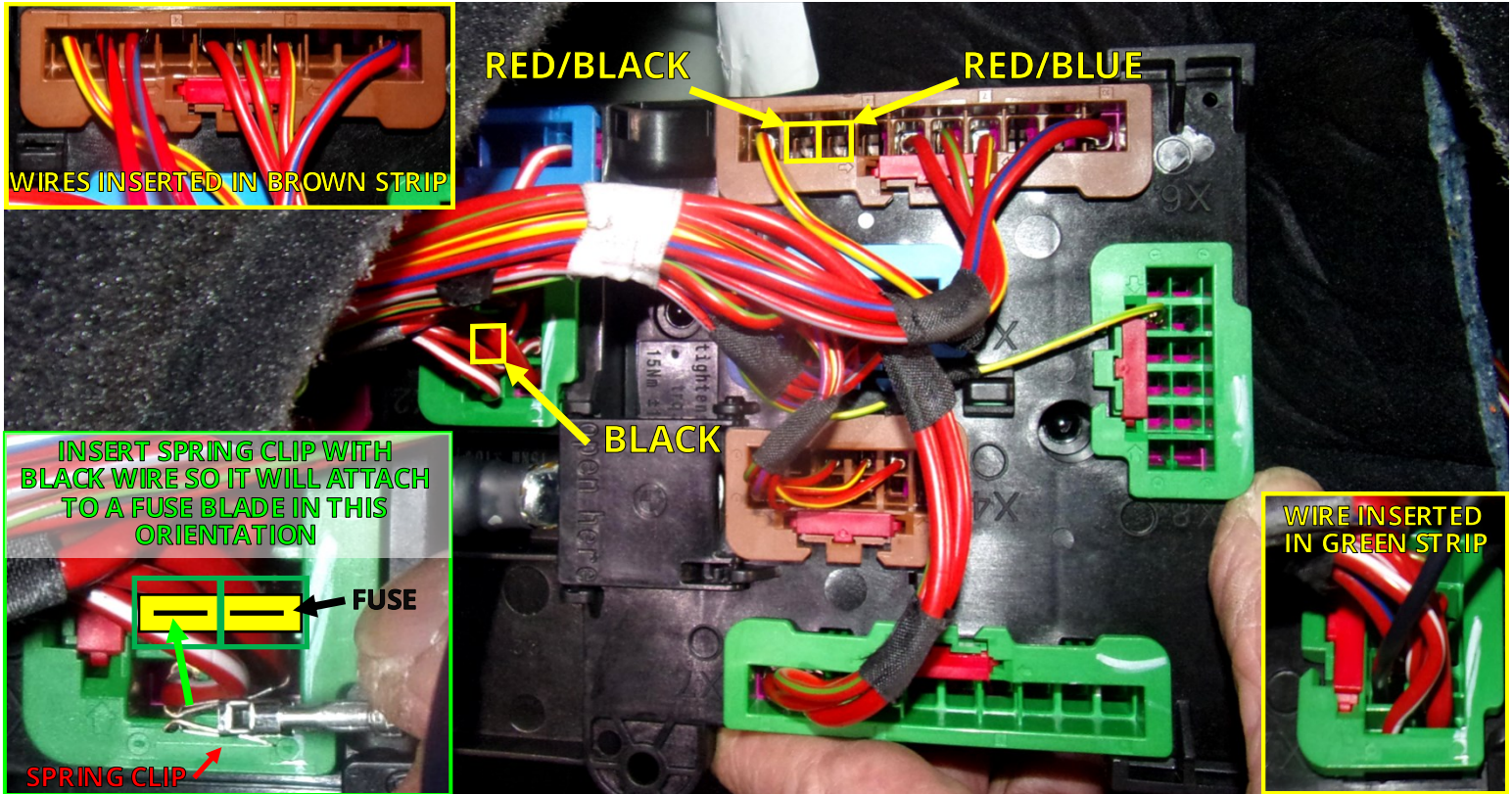

51. With all (3) wires inserted, turn the fuse panel over. Find fuse slot 267. Remove the 30 Amp fuse (green) and replace with the supplied 20 Amp fuse (yellow).

**NOTE:** Check that all fuses are still properly seated after inserting spring clip wires.





## INSTALL **ACTIVE** WIRING KIT NOT PRE-WIRED VEHICLES



90 DEGREE PICK



PLASTIC PRY TOOLS



T25 TORX

- OR -



T30 TORX

52. To connect the red and brown wires, the passenger side top rear panel needs to be removed. Use a 90 degree pick to open the small plastic cover. Use a Torx to loosen (1) screw. Use a plastic pry tool and use inward pressure to remove the panel.

USE A 90 DEGREE PICK TOOL TO OPEN PLASTIC COVER

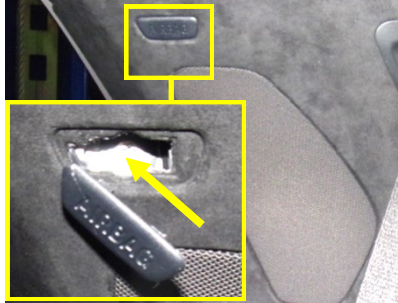

USE A T25 OR T30 TORX TO REMOVE (1) SCREW

USE A PLASTIC PRY TOOL TO REMOVE PASSENGER SIDE TOP REAR PANEL



53. If the harness bundle shown in the next step is not easily accessible, the speaker unit can be partially removed and moved out of the way. Use a socket to remove (3) screws holding the speaker unit.



8mm SOCKET

USE AN 8mm SOCKET TO REMOVE (3) SCREWS



54. Locate the indicated wire bundle. Route the black input wire from the wiring harness adapter to the wire bundle location. Trim the black wire to length and use a clamp-on connector to connect the black input wire to the black harness wire.



PLIERS

USE CLAMP-ON CONNECTOR TO CONNECT BLACK WIRES

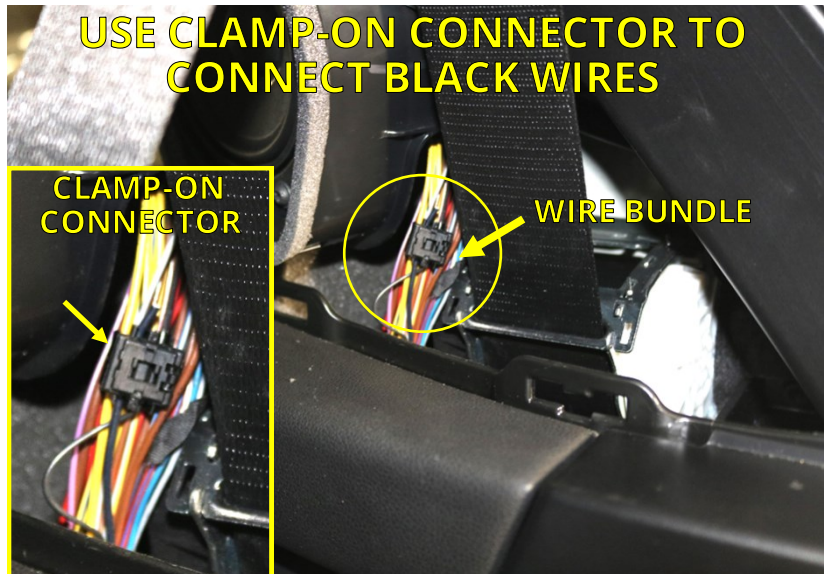

CLAMP-ON CONNECTOR

WIRE BUNDLE

55. Use a cable tie to secure the wire bundle so that it will not come into contact with any of the moving parts on the safety belt unit.



## INSTALL **ACTIVE** WIRING KIT NOT PRE-WIRED VEHICLES



PLIERS



MULTIMETER

56. Locate the indicated wire bundle in the passenger side wall. Route the green/blue input wire from the wiring harness adapter to the wire bundle location. Trim the green/blue wire to length and use a clamp-on connector to connect the green/blue input wire to the green/blue harness wire.

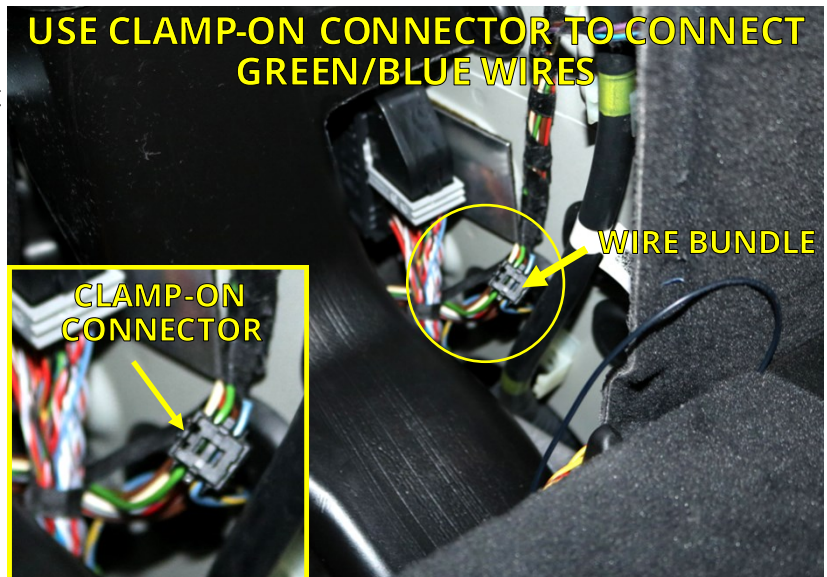

PLIERS

57. Locate the Blue/Gray and Brown/Gray wires in the indicated harness location underneath the fuse panel on the passenger side wall. Route the yellow/red and yellow/brown braided input wires from the wiring harness adapter to the wire bundle location. Trim the yellow/red and yellow/brown braided input wires to length. Use clamp-on connectors to connect the yellow/red wire to the blue/gray wire and yellow/brown wire to the brown/gray wire.

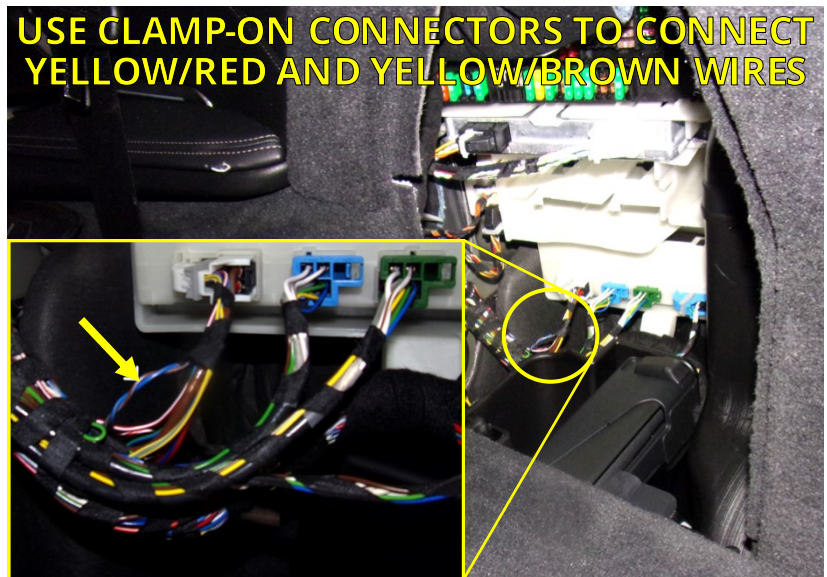

10mm  
SOCKET

58. Locate the ground stud under the third row seats on the passenger side. Use a socket to remove the ground stud nut. Route the active wiring harness ground ring from the passenger side compartment to the ground stud as shown in image. Secure the ground ring with the ground stud nut.

**NOTICE: Do not allow components already attached to ground stud to become disconnected and lose ground.**

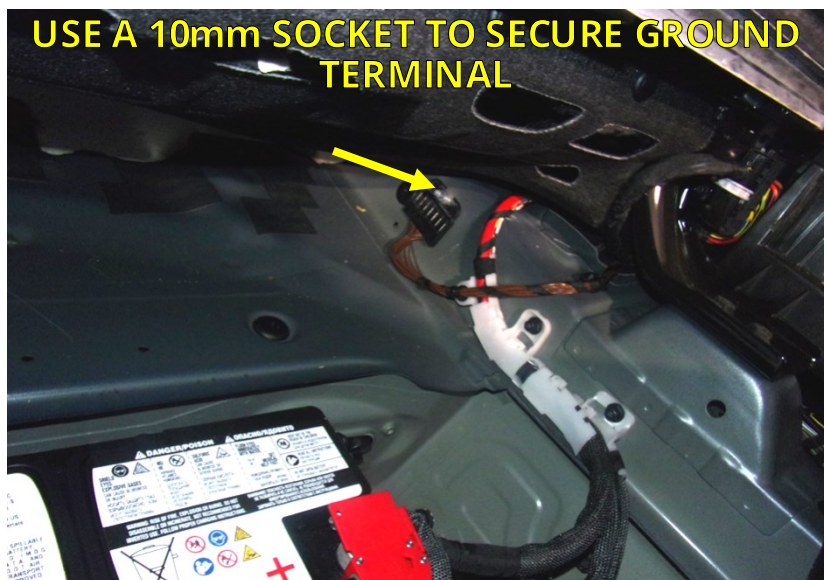



## INSTALL **ACTIVE** WIRING KIT NOT PRE-WIRED VEHICLES

59. In the active wiring kit box locate the BMW control module. Attach the active wiring harness to the control module. Plug the (24) pin connector into the "A" slot and lock it with the lock clip. Plug the (6) pin connector into the "B" slot, and the (10) pin connector into the "C" slot. Place the control module into the slot shown in the fuse panel.

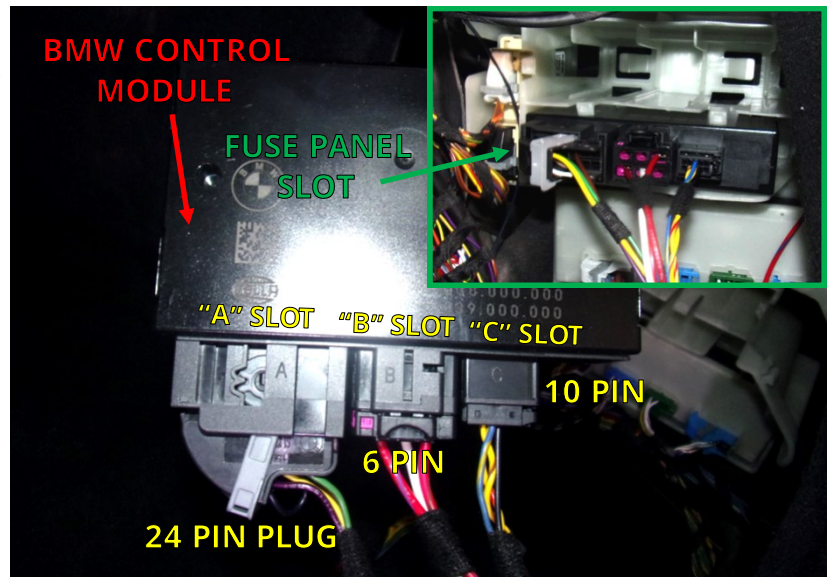

## WIRE 7-WAY PLUG



PHILLIPS HEAD  
SCREWDRIVER

60. Locate the 7-way housing. Use a screwdriver to loosen (2) screws. Remove 7-way round terminal block. Place the mounting bracket onto the 7-way housing as shown. Use a screwdriver to loosen the set screw at the bottom of the 7-way housing. Route output side wires of the wiring harness through the 7-way housing.

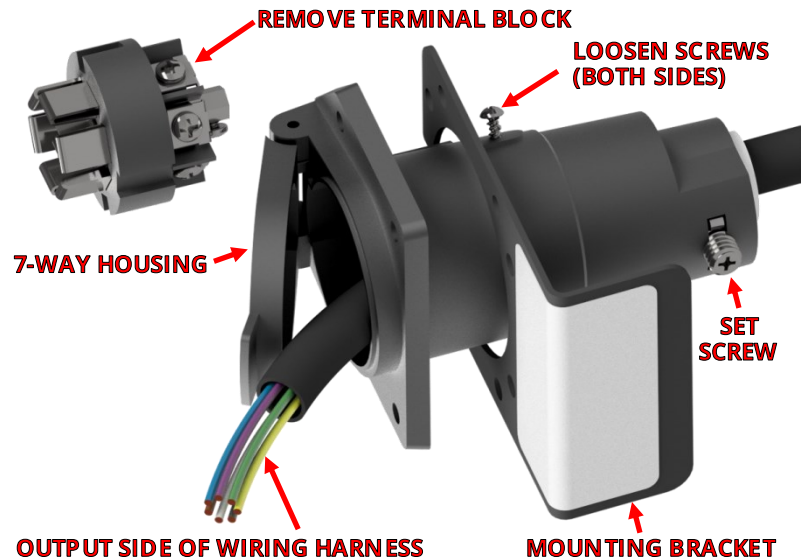

**Please follow instructions below very carefully.**

**Incorrect wiring of the 7-way receptacle causes the vast majority of wiring problems.**



PHILLIPS HEAD  
SCREWDRIVER



STRIPPER/  
CRIMPING  
TOOL

61. Locate the slot keyway. Starting from the keyway going **clockwise**, attach the wires as follows:

- Blue
- Green
- Black
- Brown
- Yellow
- White
- Purple (middle)

• Put the 7-way receptacle back together.

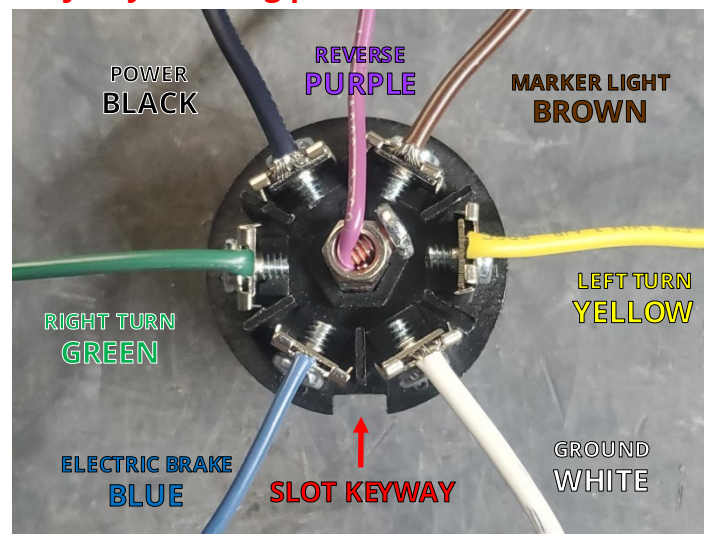

***NOTICE: Markings on the receptacle may not match the correct wire configuration. Please disregard and follow the instruction above.***



IF INSTALLING AN **ACTIVE** TOW KIT ON A PRE-WIRED VEHICLE, CONTINUE TO STEP 62.  
 IF INSTALLING AN **ACTIVE** TOW KIT ON A NOT PRE-WIRED VEHICLE, SKIP TO STEP 64.  
 IF INSTALLING A **PASSIVE** TOW KIT, SKIP TO STEP 65.

62. Inside the rear passenger side panel in the cargo area, locate the vehicle wiring harness plug.



63. Locate the large female 8-pin connector on the active wiring harness. Plug the connector into the connector located in Step 62.

**NOTICE: Plugging in the 8-pin connector will supply power to the active harness and 7-way plug.**



**Skip to Step 65 to continue installation.**

64. Locate the large female 8-pin connector on the active wiring harness. Plug the connector into the wiring harness adapter.

**NOTICE: Plugging in the 8-pin connector will supply power to the active harness and 7-way plug.**

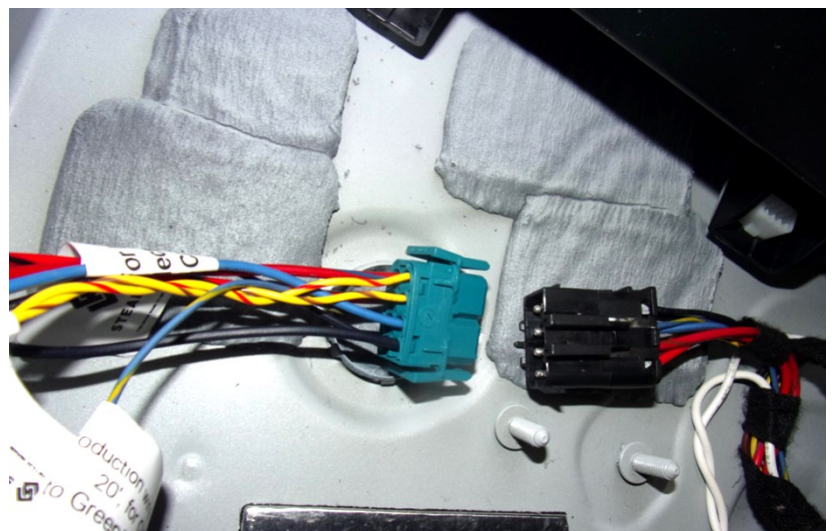



## TEST 7-WAY HARNESS WIRING



PHILLIPS HEAD  
SCREWDRIVER



MULTIMETER

65. While everything is still accessible, you should test the wiring to make sure everything is connected properly and in working order. **If installing the passive wiring harness, replace the 20 Amp fuse into the fuse holder located near the battery.**

**NOTICE:** Most **Active** harness installations will require programming before testing can be completed. Testing Active wiring harness installations with a multimeter or LED tester may not work. Some vehicles may need to "sense" the current being used by the plug to function. After programming is complete, use an incandescent light testing device or trailer to test in these specific cases.

**NOTE:** Taillights will need to be temporarily plugged in during testing.

- Start by connecting the multimeter negative probe to the ground blade on the 7-way receptacle.
- Next, connect the multimeter positive probe to the power blade on the 7-way receptacle and check for 12 volts.
- Once that is confirmed, move the positive probe to the left turn blade on the 7-way receptacle and check for 12 volts when the vehicle left turn blinker is active. You should see it pulse.
- Next, move the positive probe to the right turn blade and check for 12 volts when the right turn blinker is active. You should see it pulse.
- Next, move the positive probe to the marker/taillights. With the vehicle lights on you should see 12 volts constant.
- Lastly, with the brake depressed, move the positive probe to the left turn blade where you should see 12 volts constant. Move the probe to the right turn blade where you should also see 12 volts constant.

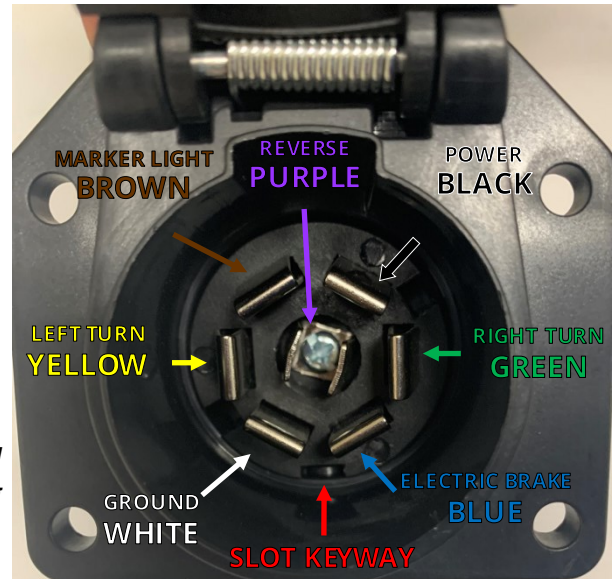

## COMPLETE WIRING KIT INSTALLATION



PHILLIPS HEAD  
SCREWDRIVER



SILICONE

66. Attach the mounting bracket and 7-way housing to the Stealth hitch frame as shown. Secure harness to Stealth hitch frame with cable ties.

67. Secure all wires and wiring components. Use the remaining cable ties to secure wiring so that it is not loose and will not interfere with replacement of the fascia. Wiring should not be visible once the vehicle is reassembled.

68. Use the provided adhesive foam strips to secure the control module to an inside body panel. Use silicone to waterproof the grommet. Reattach any passenger side trim pieces, wall panels, wired connectors, and other components removed when installing the tow kit, in reverse order.

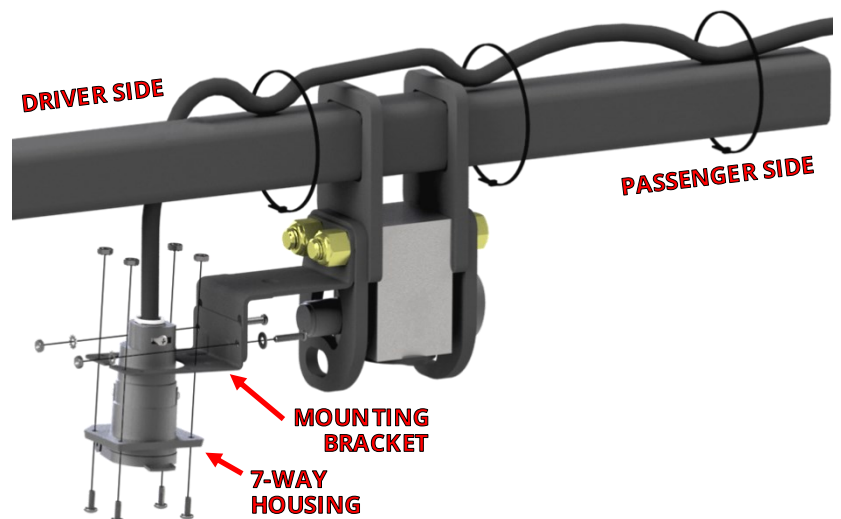

## PREPARE GRAVEL GUARD

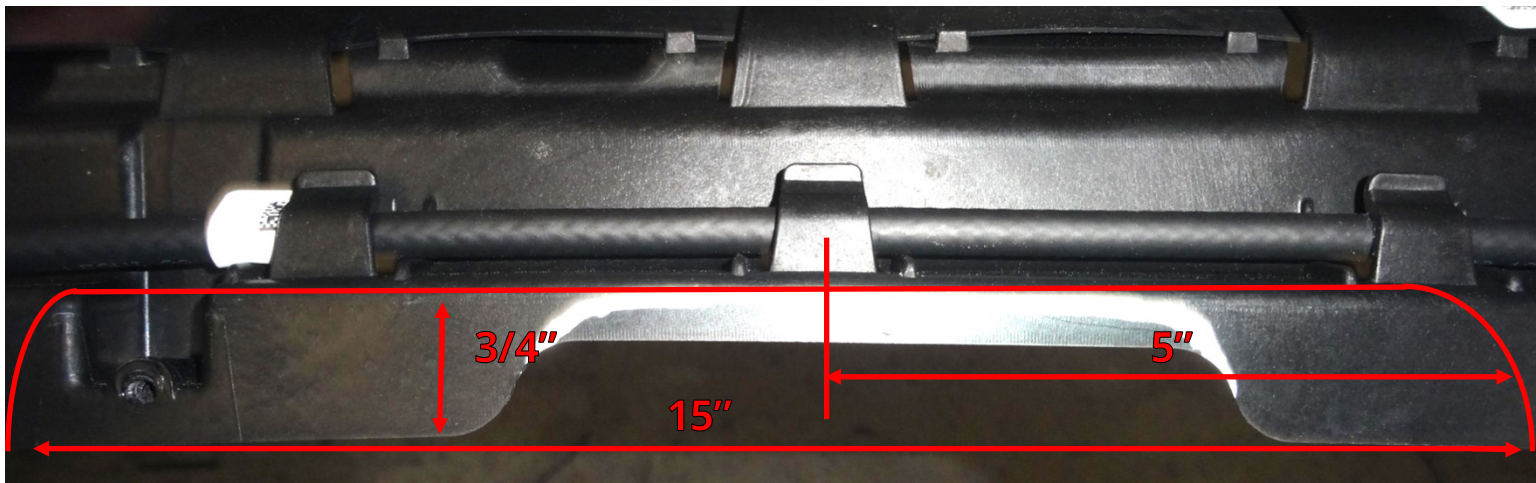

DREMEL TOOL



FILE

69. To prevent damaging the kick wand, remove the kick wand before cutting. Use a Dremel tool or something similar to make the cut in the kick wand panel as shown in the image. Use a file to smooth out the cut.

70. Reattach the plastic kick wand panel with (3) rivets to the Stealth hitch frame. Reattach the wiring harness, unplugged in Step 17 to the plastic kick wand panel.

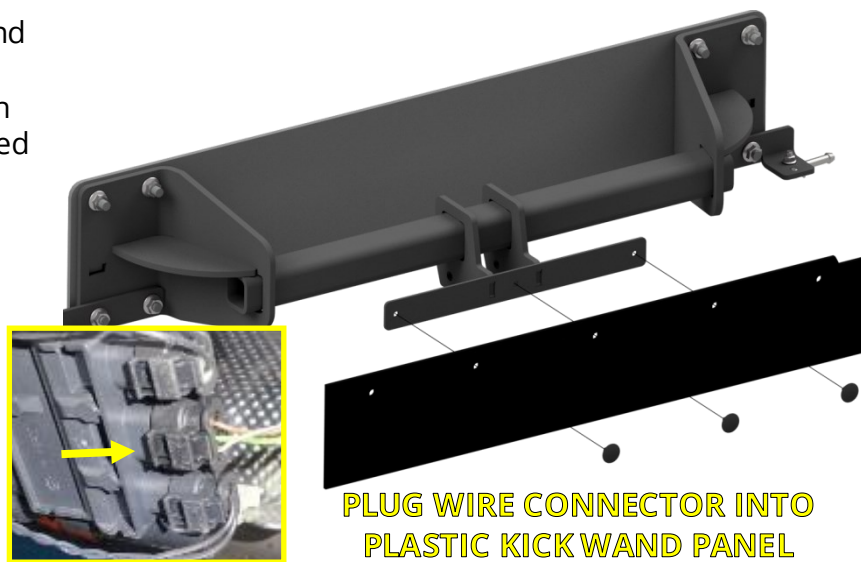

PLUG WIRE CONNECTOR INTO PLASTIC KICKWAND PANEL

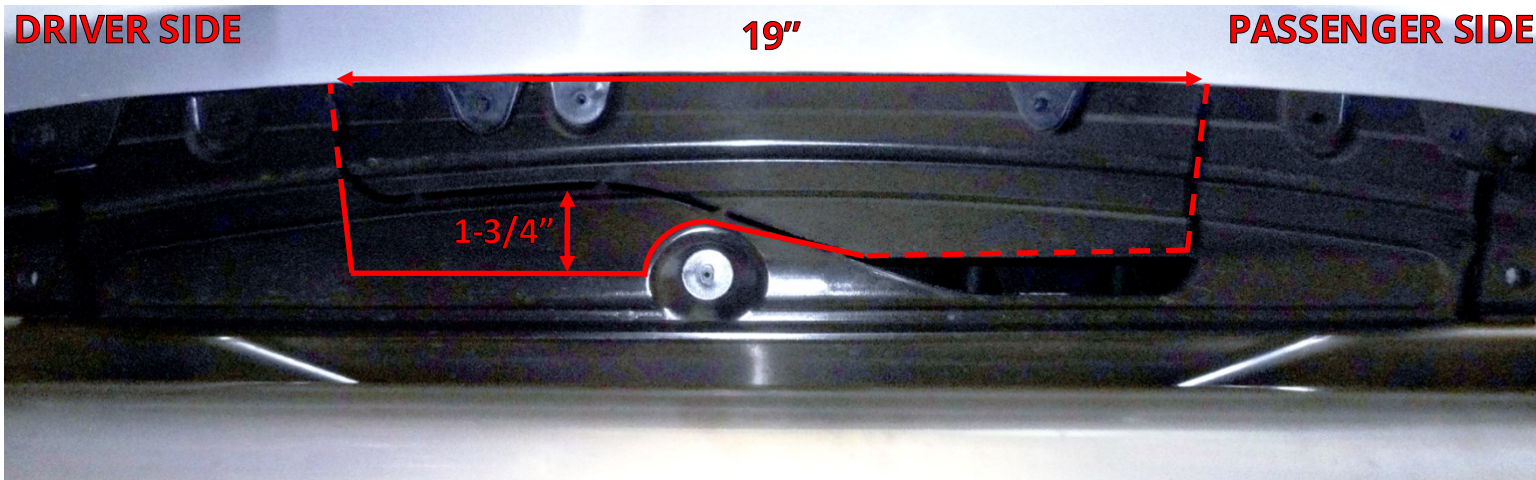

DREMEL TOOL



FILE

71. Cut out the gravel guard with Dremel tool. Use a file to smooth out the cut.



## REINSTALL VEHICLE COMPONENTS

72. While holding the fascia close to the vehicle, plug in the PDC sensor plug, before replacing the fascia onto the vehicle.

***NOTICE: It's important to remember to plug in the PDC sensor plug before you completely install the fascia.***

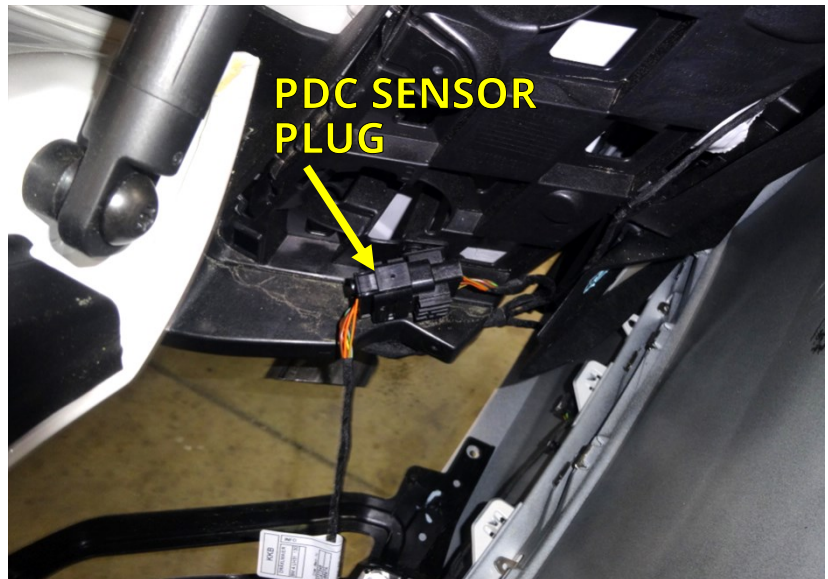

73. Make sure to have all (4) clips aligned with the clip holders before you push to replace the fascia.

74. Reattach and secure the fascia, taillights, and other vehicle components in reverse order. Refer to Steps 1-14.



## FINAL VEHICLE EXAMINATION

75. Examine the body panels to ensure that they are in a pre-installation condition. Test the electronic functions of the vehicle. Correct any inconsistencies.
76. Ensure that hitch components work properly.
  - **Verify that the lock works correctly.** Push in the safety lock on the latch block then unlock with key. The lock should slide back out with the key when unlocked.
  - **Verify that each accessory can be installed correctly.** Use the following steps to install and remove each accessory that will be used with the hitch. (*Rack Receiver* and *Ball Mount* if purchased.)
    1. Prepare latching mechanism. Turn handle clockwise if needed.
    2. Firmly insert "post" of accessory into latch block until handle releases indicating that the accessory is latched.
    3. Push in the safety locking pin until it fully engages. The locking pin prevents the handle from turning when pushed in, and confirms that the block is securely latched onto the accessory. The safety locking pin will not depress if the accessory is not fully latched.
    4. Use key to release safety locking pin.
    5. While holding on to the accessory, rotate handle clockwise to release and remove the accessory.
  - **Verify that no part of the accessories come into contact with the body of the vehicle.**

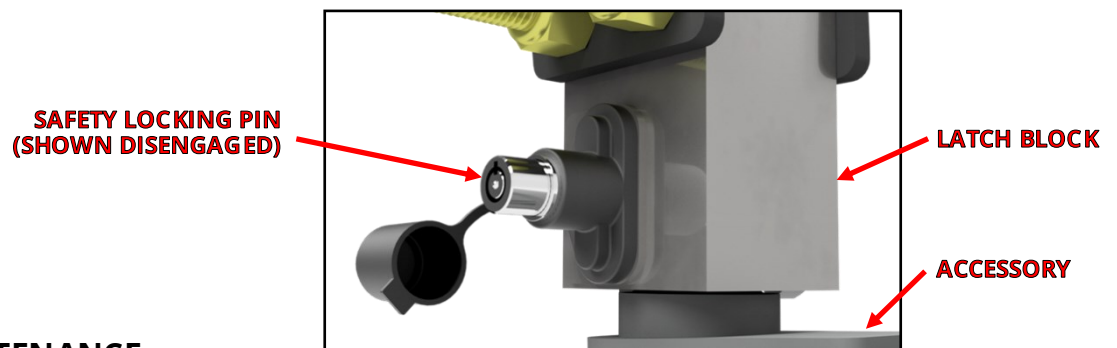

## PRODUCT USE AND MAINTENANCE

**NOTICE: If the hitch is being installed by a professional, the installer is responsible for training the end user in the use and maintenance of the product.**

- **Accessory installation procedure:**
  1. Prepare latching mechanism. Turn handle clockwise if needed.
  2. Firmly insert "post" of accessory into latch block until handle spins counter-clockwise indicating that the accessory is latched.
  3. Always depress the safety locking pin and check that it has fully engaged.
- **Never use any accessory with the safety lock disengaged.** Until the safety locking pin is engaged, the handle is able to turn. A fully engaged safety locking pin is confirmation that the accessory is properly latched into the latch block.
- **Never use the rack receiver for towing.** The rack receiver accessory is only to be used with payload carrying products, such as bike racks or luggage racks.
- **Before each use, give the post of the accessory a light coating of lithium based grease.**
- **Before each use, inspect the hitch to ensure that all bolted connections are secure and that no cracks or damage are present.** Do not tow with the hitch if cracks or damage outside of normal wear is found.
- **Remove the Stealth accessories from the latch block after each use.** Do not leave accessories plugged in for extended periods of time.