



www.stealthhitches.com 833-694-4824

HITCH INSTALLATION INSTRUCTIONS

MAKE:	YEARS:	MODEL/TRIM:
BMW	2015 - 2018 2015 - 2019	X5M (F85 CHASSIS) X6M (F86 CHASSIS)

RACK RECEIVER KIT BOX#: **SHR31030**

COMPATIBLE WITH TOW KITS: **SHT25011 & SHT25012A**



2" RACK RECEIVER MAXIMUM PAYLOAD: 600 LBS
MAXIMUM TOW RATING: 8000 LBS
MAXIMUM TONGUE WEIGHT: 800 LBS

UNDER VEHICLE TRIMMING:

HEAT SHIELD: **NO**
 FASCIA: **NO**
 GRAVEL GUARD TRIMMING: **NO**



READ ALL INSTRUCTION WARNINGS AND LABELS



NO WELDING, METAL DRILLING OR VISIBLE TRIMMING REQUIRED

PARTS SUPPLIED WITH RACK RECEIVER KIT:

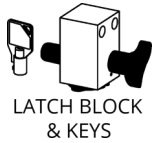

LATCH BLOCK & KEYS

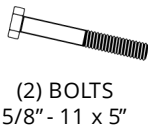

(2) BOLTS
5/8" - 11 x 5"



(2) 5/8"
NYLOCK NUTS

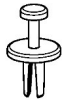

(6) PLASTIC
RIVETS

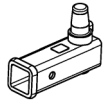

2" RACK
RECEIVER

ADDITIONAL PARTS FOR TOW KIT:

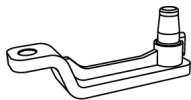

BALL MOUNT
5" RISE, SHORT



CHAIN HOOKS



2" BALL

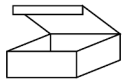

PASSIVE OR ACTIVE
WIRING HARNESS KIT
BOX

TOOLS REQUIRED:



15/16" OPEN
END WRENCH



18mm DEEP WELL,
8mm, 10mm
& 15/16" SOCKETS



RATCHET

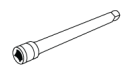

SOCKET
EXTENSION



TORQUE
WRENCH



5/16"
ALLEN WRENCH



FLASHLIGHT



PLASTIC
PRY TOOLS



SAFETY GLASSES



90 DEGREE
PICK



RAZOR KNIFE



PAINTER'S TAPE

ADDITIONAL TOOLS FOR ACTIVE & PASSIVE TOW KITS:



T30 TORX
(ACTIVE ONLY)



STRIPPER/
CRIMPING
TOOL



PHILLIPS HEAD
SCREWDRIVER



MULTIMETER

ADDITIONAL TOOLS FOR PASSIVE TOW KIT:



PLIERS



DRILL &
3/8" BIT



SILICONE

RACK RECEIVER KIT INSTALLATION: USE STEPS 1-23, & 50-52

PASSIVE TOW KIT INSTALLATION: USE STEPS 1-35, & 44-52

ACTIVE TOW KIT INSTALLATION: USE STEPS 1-28, & 36-52

NOTICE: If installing an ACTIVE tow kit, the vehicle must be programmed before trailer lights will function, see notice on Page 3.

<THESE INSTRUCTIONS MUST BE GIVEN TO THE END USER>

NOTICE: Installation of Stealth products may or may not require the addition of a wiring harness to the vehicle.

- The Rack Receiver only product does not require adding a wiring harness.
- The Rack Receiver plus Tow Kit requires the addition a wiring harness that is compatible with the vehicle's wiring. Depending on the vehicle, the harness will be one of two types, "Active" or "Passive." The wiring section of the instructions will indicate which wiring harness style is being used and how to install it.
- The **Active Harness** plugs into the vehicle's wiring so that the vehicle's computer can communicate with the trailer wiring. This allows certain functions such as cameras or backup alarms to continue to operate as designed. Some active harnesses require reprogramming of the vehicle's computer before the trailer wiring is functional. For BMW vehicles that need programming, Stealth provides this service remotely. Refer to the Active Harness section of the instructions to determine if programming is required for this install. ***This programming must be taken into account when planning the timing of the Stealth product install. The remote BMW programming needs to be scheduled approximately 1 week in advance.***
- The **Passive Harness** is independent of the vehicle's computer and communication system. The module of the harness is powered directly from the battery rather than the vehicle's wiring harness. The module monitors the output signals from the vehicle's lights. It then powers and activates the trailer lighting accordingly.

INSTALLATION NOTE: In most instances, these instructions will only outline disassembly of vehicle components. Re-installation of components will require the installer to retain vehicle hardware and work through disassembly instructions in reverse order. When installation is complete, double check that all vehicle components have been replaced and are secured.

IMPORTANT SAFETY NOTICE FOR STEALTH HITCH INSTALLERS AND CUSTOMERS.

Read all installation and operating instructions along with all labels before installing or using this product. Do not perform any installation or towing procedures without fully understanding the correct tools and actions for all steps. Call for support if needed.

⚠ WARNING Failure to comply with the safety information in these instructions could result in serious injury or death.

- ⚠ Do not modify this product in any manner. Doing so could alter its integrity and lead to a loss of attachment between the trailer and the tow vehicle.
- ⚠ Adding Stealth hitch components to the chassis of any vehicle can be hazardous. There is potential for unexpected combustion of fuel, electric shock, burns, shifting or falling of unstable vehicle, damage to vehicle, injury from tool usage and many other hazards. This installation must be completed by someone who is aware of the hazards involved. This person must be knowledgeable of proper safety procedures for a vehicle modification of this nature, and for usage of the equipment required to perform the installation.
- ⚠ Without proper knowledge, towing can be a dangerous activity. Understand all the risks involved with towing before proceeding. For information on towing safety, see "**The Trailer Handbook: A Guide to Understanding Trailer and Towing Safety**" from the National Association of Trailer Manufacturers, www.NATM.com and your trailer and tow vehicle manufacturer's owner's manual.
- ⚠ Do not exceed tow or tongue rating of coupler, tow or tongue rating of hitch, or tow or weight ratings of tow vehicle or trailer. See vehicle and trailer manufacturer information for ratings. Exceeding these ratings may cause damage to towing components or loss of attachment between the trailer and vehicle.
- ⚠ While installation is being performed, check for signs of damage or excessive corrosion. Do not install hitch components over vehicle parts that are broken or have compromised structural integrity.
- ⚠ This product was designed to fit vehicles in their original, "as manufactured" condition. Compatibility with vehicles having replacement parts, or other modifications is not guaranteed. Inspect vehicle for modifications before installation of this product.
- ⚠ Some accessories, like the rack receiver, are not rated for towing. Do not use any accessories without proper knowledge of their use.
- ⚠ A visual inspection of the hitch should be performed before each use. Regularly check that all connections are secure, including those that secure the hitch to the vehicle. Check for cracks or damage to the hitch. Do not use the hitch if cracks or damage outside of normal wear is found. Using a hitch that has unsecure connections and/or cracks or damage could result in damage to the tow vehicle, trailer, towing components and loss of attachment between the tow vehicle and trailer.
- ⚠ Stealth hitches are not compatible with any weight distribution or sway control products. Adding additional products to the trailer or chassis which modifies the function of the Stealth hitch may cause hitch failure.

NOTICE: Installation of hitch requires removal of vehicle parts and interaction with vehicular electronics. Before installation, check the condition of body panels and note any locations where panels are not flush. Check the electronic functions of the vehicle, such as: headlights, taillights, turn signals, cameras, backup sensors, Parking Distance Controller (PDC), foot activated cargo access, etc. It is the responsibility of the installer to restore the fit and function of the vehicle.

NOTICE: If installing an active wiring harness, your vehicle must be programmed. Arrangements can be made with Code My Car (585-496-4648). Please allow at least a week to make programming arrangements. Programming will require your vehicle to be connected to a computer and an internet connection. **Note:** A programming code is affixed to the control module and the programming cord which will be needed when contacting Code My Car. Additional programming changes may be available at time of programming. Arrangements can be made when contacting Code My Car.

GAIN ACCESS TO MOUNTING AREA

1. Open vehicle cargo area and remove left and right side panels for access to rear of the taillights.



2. Locate nuts (2) securing the taillights to the vehicle on either side of the trunk and remove.



GAIN ACCESS TO MOUNTING AREA CONTINUED

3. Unplug the wiring harness from the taillight by pushing down on the clips and pulling away from the lights.

NOTE: In some cases, it may be helpful to dislodge the light from the vehicle for better access to the plugs.



4. Remove taillights by sliding to the rear of the vehicle. A plastic pry tool can be used if necessary.
5. Use a socket to remove screw in the bottom of each light location.



GAIN ACCESS TO MOUNTING AREA CONTINUED



6. Locate the rivets inside the rear wheel wells. Use a 90 degree pick or a pry tool to remove (3) most rearward plastic rivets. The rivets secure the wheel well trim to the vehicle.

NOTE: Make sure not to damage the wheel well trim piece.

NOTE: Replacement plastic rivets are supplied.



7. To allow partial removal of the rear wheel well trim, clips (3) will need to be disconnected. Apply outward pressure on wheel well trim. Start with the bottom clip and work up. Push down on clip to disconnect. Use plastic pry tools on hard to reach clips.

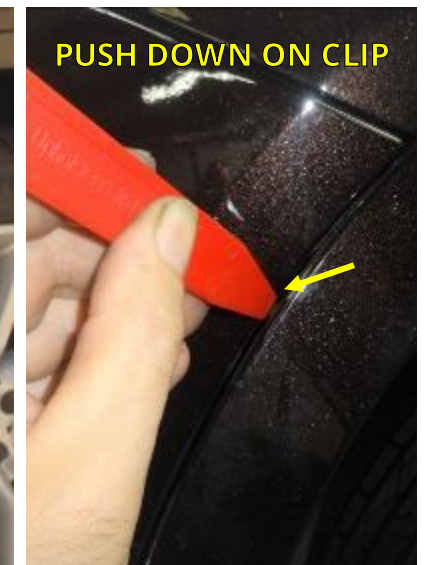
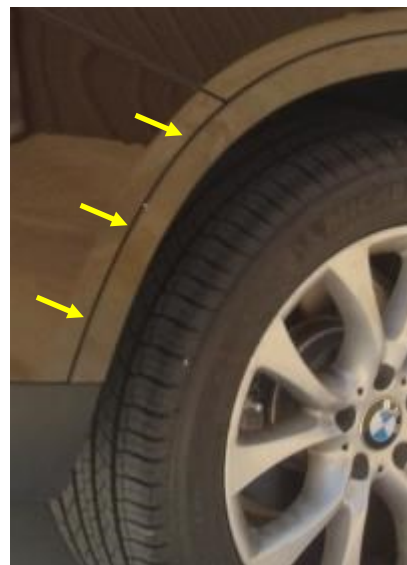

8. Behind the rear wheel well trim is a screw holding the fascia. Pull the trim away from vehicle to expose screw. Use a socket to remove screw. Repeat Steps 6-8 on other side of vehicle.

NOTE: To protect the trim from being scratched during the removal or replacement, cover it with painter's tape or something similar.



GAIN ACCESS TO MOUNTING AREA CONTINUED



9. Remove the two reflectors directly below each taillight location. Each reflector is clipped into vehicle in three places. On some vehicles, the center clip is accessible under the vehicle. Push upwards and to the rear of the vehicle to disengage this clip.

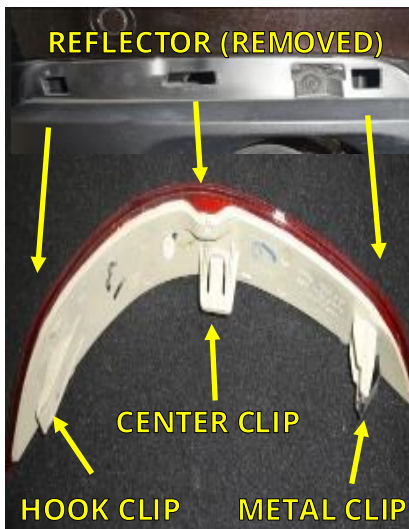

8mm
SOCKET

10. Starting on the side closest to the center the vehicle, use a plastic pry tool to remove each reflector.



11. A screw, which is holding the fascia, will be exposed when the reflector is removed. Use a socket to remove the screw.



GAIN ACCESS TO MOUNTING AREA CONTINUED



8mm
SOCKET

12. From underneath the vehicle, use a socket to remove (6) screws from the bottom edge of the fascia.



PLASTIC
PRY TOOLS

13. The fascia is clipped to the vehicle body directly behind the wheel wells. Pull outward on the fascia to expose the first clip in the seam. With a plastic pry tool, push down on the exposed clip to disconnect. Continue to pull outward on the fascia and disconnect clips as they are exposed. The last two clips will be in the bottom of the light housing. Repeat on other side of vehicle.

NOTE: X6 will look slightly different.

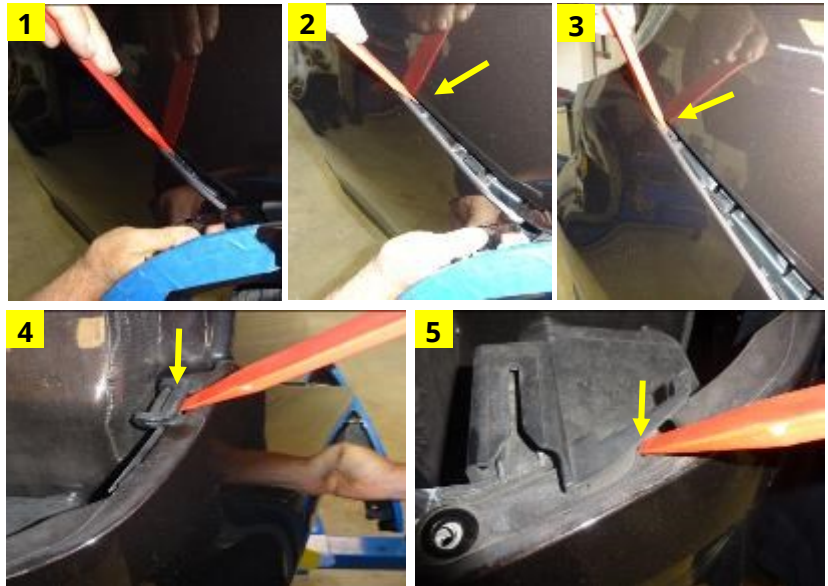

5/16"
ALLEN WRENCH

- X5 ONLY.** While positioned behind the center of the vehicle, locate the (4) remaining clips holding the fascia. Before disconnecting each clip, put rearward pressure on the fascia. Starting from one side, use an Allen wrench to push down and disconnect each clip.

NOTE: Use caution when pulling the fascia rearward. The fascia is still connected to the vehicle by a wire harness.

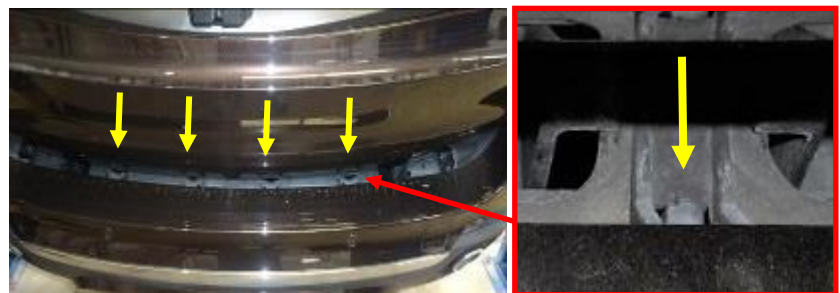

USE 5/16" ALLEN WRENCH TO PUSH
DOWN ON CLIPS



GAIN ACCESS TO MOUNTING AREA CONTINUED



15. This step requires a partner. Pull the fascia rearward enough to access the PDC sensor plug on the passenger side. Press down on the clips to unplug the PDC sensor. In some cases a 90 degree pick tool will be needed to disconnect the sensor plug. Remove the fascia completely.

NOTICE: Carefully remove the fascia and place on a blanket or pad.

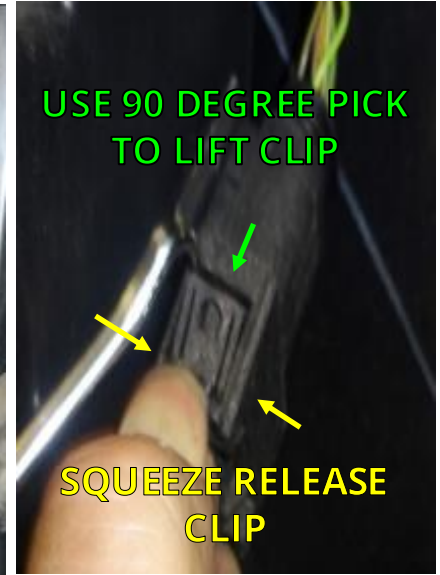
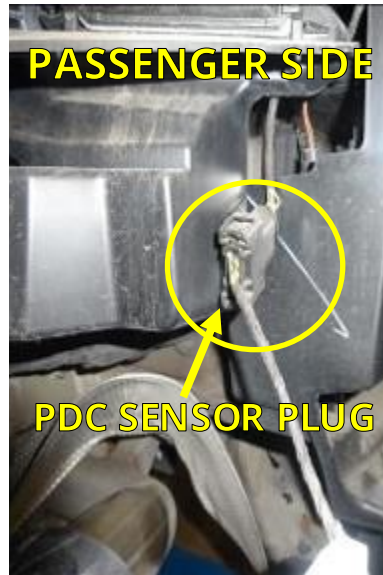

16. **X5 ONLY.** Use a socket to remove (4) nuts from the fascia support. Disconnect the two clips from the fascia support. The fascia support may still be attached to the vehicle by a wire harness. Removal of the wire harness is not required. Allow the fascia support to hang down. Repeat on other side of vehicle.

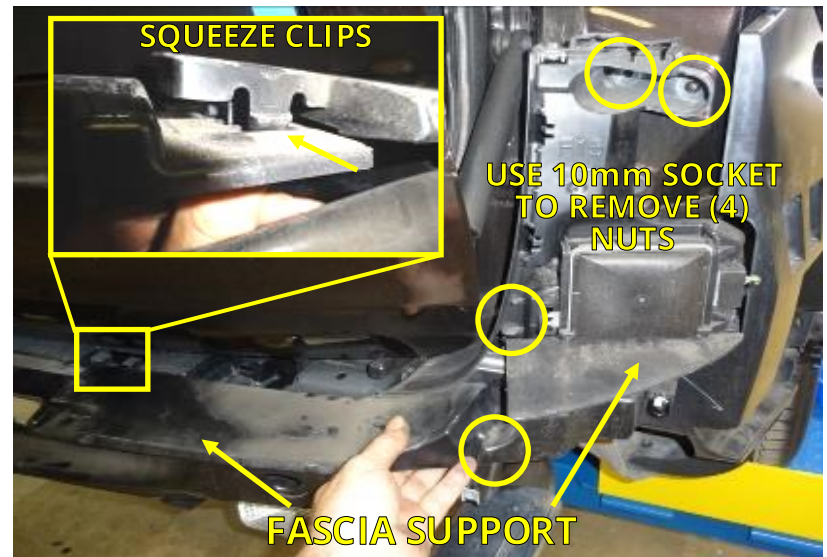

17. **X5 ONLY.** Some vehicles have plastic stud covers on the nuts that secure the factory reinforcement beam. Unscrew stud covers and **save for later reinstallation.**



18. **X5 ONLY.** Remove the wire harness clip from the factory reinforcement beam, on the passenger side.

GAIN ACCESS TO MOUNTING AREA CONTINUED



RAZOR KNIFE

19. **X5 ONLY.** If you removed plastic stud covers from your vehicle, trim 1/4" off the open end. This will accommodate the thicker Stealth hitch frame.



18mm
DEEP WELL
SOCKET

20. Use a socket to remove the (8) nuts that secure the factory reinforcement beam to the vehicle. **Save the nuts for the hitch installation. Discard the factory reinforcement beam.**

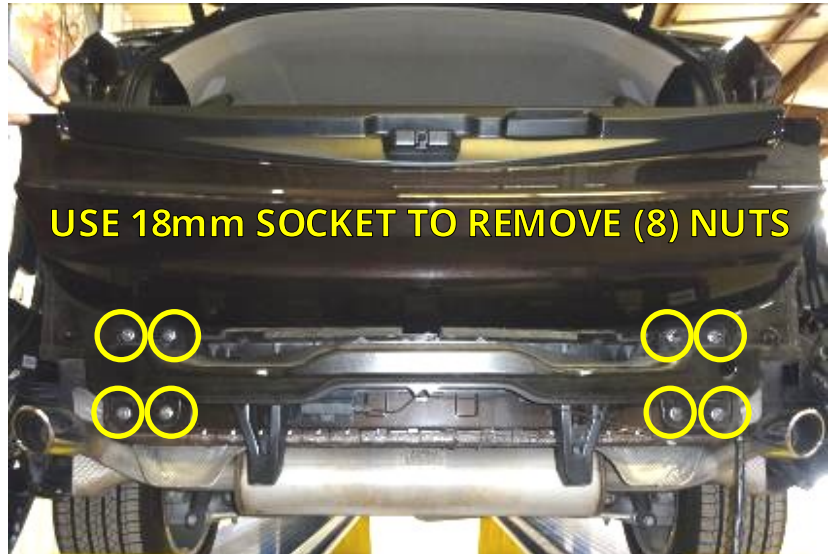

INSTALL STEALTH HITCH FRAME



18mm
DEEP WELL
SOCKET



TORQUE
WRENCH

21. Install the Stealth hitch frame onto the vehicle studs. Center the hitch frame. Use a torque wrench to tighten the factory nuts to 85 ft.-lbs. If removed earlier, replace trimmed plastic stud covers.

NOTE: X6 will look slightly different.



INSTALL STEALTH HITCH FRAME CONTINUED



10mm
SOCKET

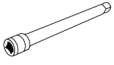

SOCKET
EXTENSION

22. **X5 ONLY.** Reinstall the fascia support pieces removed in Step 16 by replacing the (4) nuts and reconnecting the two clips.



USE A 10mm SOCKET TO
REINSTALL NUTS

MOUNT LATCH BLOCK



15/16"
SOCKET



TORQUE
WRENCH



15/16" OPEN
END WRENCH

23. Installation of the latch block varies depending on which kit you are installing.

- **Rack Receiver Kit:** Install the latch block with (2) 5/8"-11 x 5" bolts and (2) 5/8" nylock nuts. Tighten each bolt to 150 ft.-lbs.
- **Tow Kit:** Retrieve L-bracket from wiring harness kit box. Install the latch block, (2) chain hooks, and L-bracket with (2) 5/8"-11 x 5" bolts and (2) 5/8" nylock nuts. Tighten each bolt to 150 ft.-lbs.

NOTICE: Keys are packaged within the latch block, remove keys and store in safe location.

RACK RECEIVER KIT INSTALL



TOW KIT INSTALL

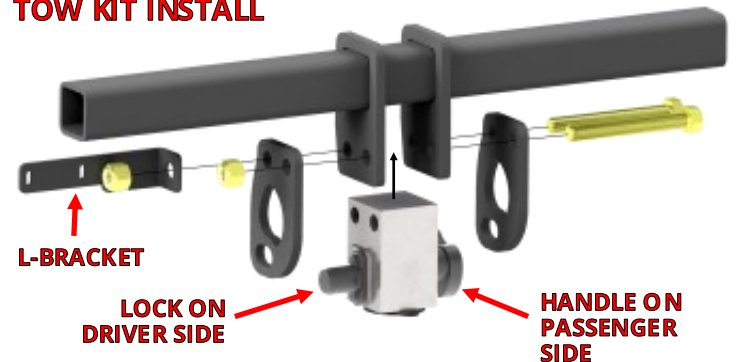

IF INSTALLING A RACK RECEIVER KIT, SKIP TO STEP XX.
IF INSTALLING A TOW KIT, CONTINUE TO STEP 24.

INSTALL WIRING KIT

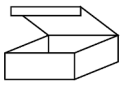

PASSIVE OR ACTIVE WIRING HARNESS KIT BOX

24. Locate the wiring kit box. Review the contents of the box against the list below to check for missing components.

- **The passive wiring kit** uses a control module to manage the functions of the trailer lighting. The module has an “input” side that receives power from the vehicle’s battery and signals from the vehicle’s taillights. The “output” side of the module delivers this information to the 7-way plug, see *passive harness diagram*. The control module is connected to the vehicle’s battery and taillight wiring as outlined in the next steps.
- **The active wiring kit** uses a BMW computer control module to manage the functions of the trailer lighting. The module must be “programed” before it will be functional. The module will connect to the vehicle through an included wire harness. The harness has an “input” side that receives power and signals from the vehicle’s electronic systems. The “output” side of the harness delivers this information to the 7-way plug. The harness and computer module installation are outlined in the next steps.

NOTICE: Do not allow electrical system to become disconnected from power or ground. Doing so may interrupt electrical systems.

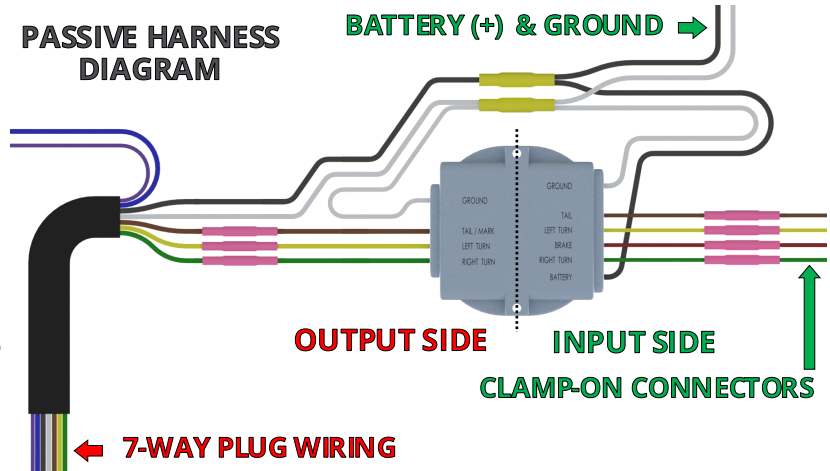

PASSIVE WIRING KIT BOX

PASSIVE WIRING KIT BOX ITEMS		
#	DESCRIPTION	QTY
1	7-WAY WIRING HARNESS <ul style="list-style-type: none"> • FUSE HOLDER & FUSE • CONTROL MODULE & WIRES 	1
2	ADHESIVE FOAM STRIP	2
3	FORK TERMINAL	1
4	CLAMP-ON CONNECTORS	4
5	5/8" LONG PHILLIPS SCREWS	4
6	#10 LOCK NUT	4
7	CABLE TIE - 8"	4
8	CABLE TIE - 14"	2
9	L-BRACKET	1
10	MOUNTING BRACKET	1
11	7-POLE HOUSING	1
12	7-POLE TO 4-POLE ADAPTER	1



ACTIVE WIRING KIT BOX



ACTIVE WIRING KIT BOX ITEMS		
#	DESCRIPTION	QTY
1	WIRING HARNESS	1
2	BMW CONTROL MODULE	1
3	5/8" LONG PHILLIPS SCREWS	4
4	#10 LOCK NUT	4
5	CABLE TIE - 8"	4
6	CABLE TIE - 14"	2
7	L-BRACKET	1
8	MOUNTING BRACKET	1
9	7-POLE HOUSING	1
10	7-POLE TO 4-POLE ADAPTER	1
11	VEHICLE PROGRAMMING CABLE	1

INSTALL WIRING KIT CONTINUED



25. Locate the cargo holder in the passenger side of the vehicle cargo area. Remove (3) plastic rivets with plastic pry tool. Pull up on cargo holder to remove. **Save rivets for reinstallation.**



26. Place the harness in the passenger side of the vehicle cargo area. Locate the two grommets directly above the exhaust on the passenger side. Remove the grommet without a harness through it.

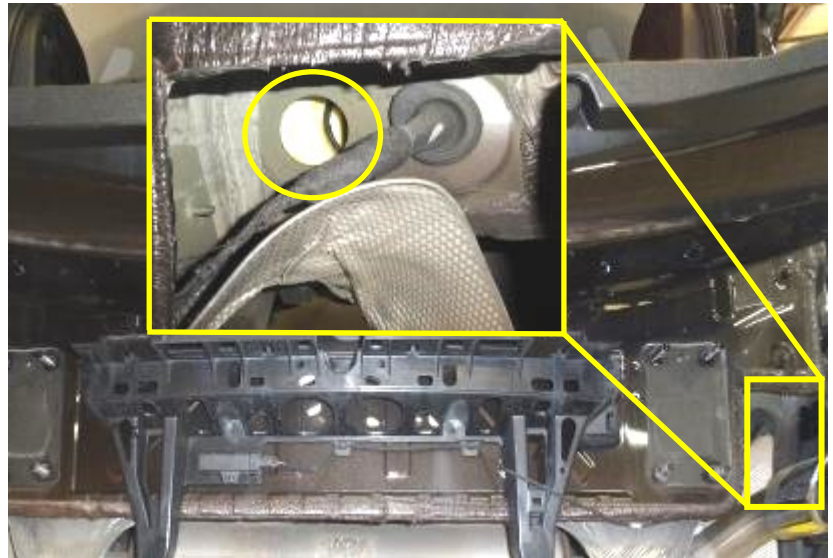

DRILL &
3/8" BIT

27. **If installing the passive tow kit:** Drill a hole in grommet. The output wires of the control module will exit the vehicle where the grommet was removed. Route output wires through the grommet.

NOTE: Grommet will be waterproofed in a later step.

If installing the active tow kit: Discard the grommet.



INSTALL WIRING KIT CONTINUED

28. Guide the output harness wires from inside of the vehicle to outside of the vehicle. Make sure the grommet is properly seated in the hole.

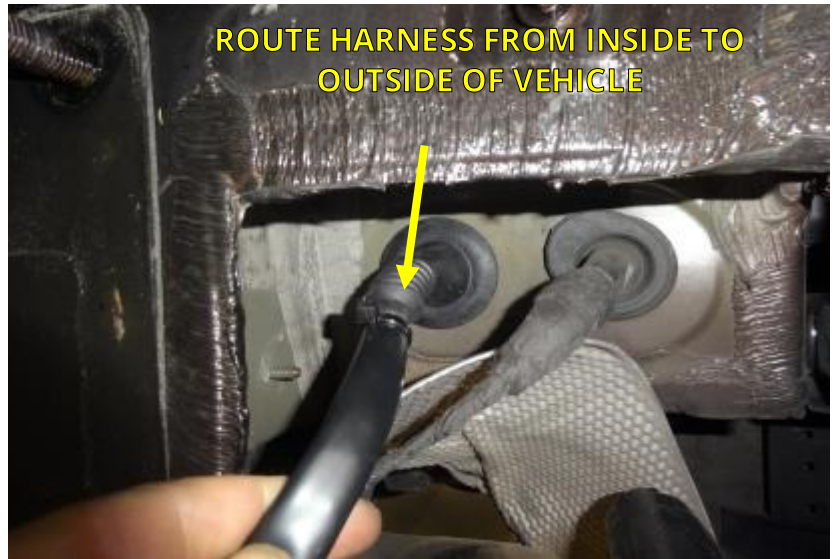

IF INSTALLING A **PASSIVE** TOW KIT, CONTINUE TO STEP 29.
IF INSTALLING AN **ACTIVE** TOW KIT, SKIP TO STEP 36.

INSTALL **PASSIVE** WIRING KIT



8mm
SOCKET

29. In the rear vehicle cargo area lift out floor covering concealing the battery compartment. Remove (5) screws from the battery cover to gain access to the battery compartment.

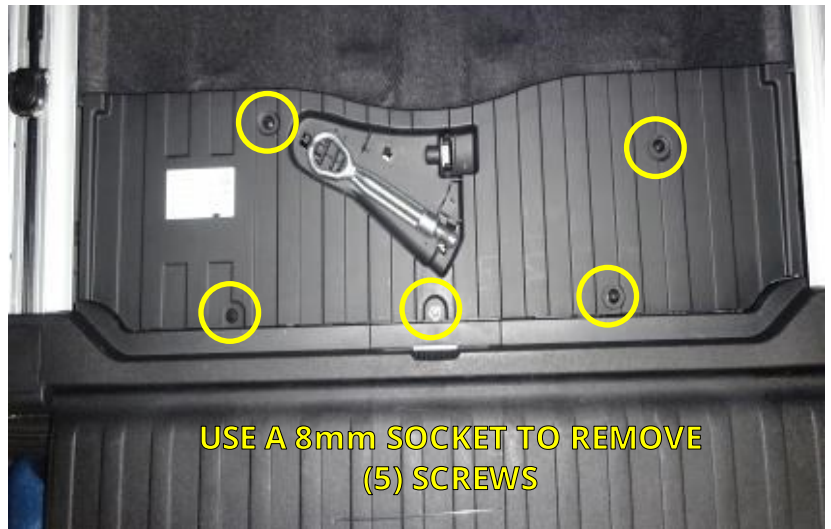

30. From the passenger side of the vehicle, route the yellow input wire to the driver side of the vehicle through the battery compartment using an existing wire harness as a guide.



INSTALL PASSIVE WIRING KIT CONTINUED



PLIERS



MULTIMETER

31. The wires on the input side of the wiring module need to be attached to the vehicle wiring. Use clamp-on connector to clamp the yellow wire to the left turn signal wire, behind taillight. (See reference table below.)

Note: Vehicles may have different wire colors than those shown. Verify circuits (wire colors) with multimeter.

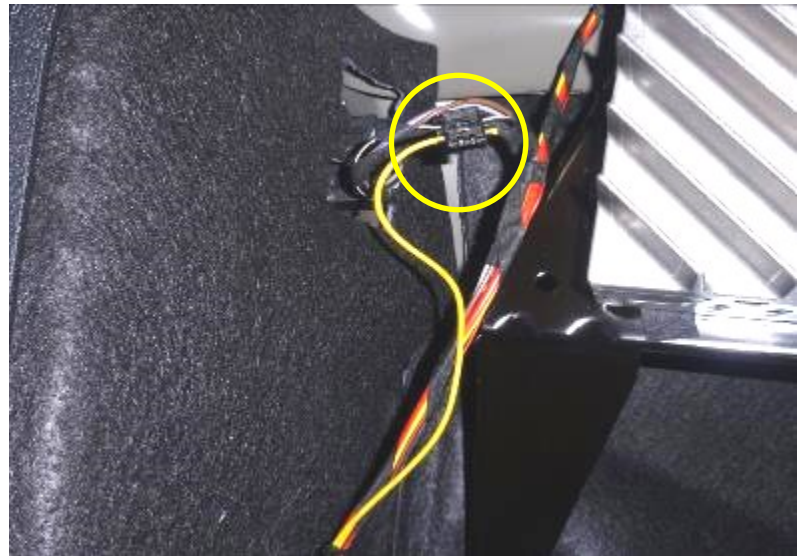

PLIERS



MULTIMETER

32. Inside the passenger side compartment, use clamp-on connectors to connect the green and brown wires to wires behind taillight. (See reference table below.)



CLAMP-ON CONNECTOR COLOR REFERENCE TABLE

SIGNAL INPUT WIRES			POWER & GROUND WIRES		
FUNCTION	HARNES	VEHICLE			
LEFT TURN	YELLOW	BLACK/WHITE	12V+ (POWER)	BLACK	BATTERY (+)
RIGHT TURN	GREEN	BLACK/GREY	GROUND	WHITE	GROUND STUD
MARKER	BROWN	GREY/YELLOW			
BRAKE	RED	Do not connect the red brake wire. This vehicle does not utilize a separate brake circuit. The brake signal is sent down the left and right turn circuits simultaneously.			
REVERSE	PURPLE	For use with trailer reverse lights or to disable the trailer brakes when backing with surge brakes. To connect, isolate vehicle's reverse light circuit and connect the purple wire from the trailer wiring harness to vehicle reverse light circuit. Trailers rarely have reverse lights or surge brakes.			
ELECTRIC BRAKE	BLUE	Only used when a hard wired brake controller is mounted inside the vehicle and your trailer has electric brakes. See brake controller instructions for this wire.			

NOTE: If two colors are listed, the first color is the dominant color.

INSTALL PASSIVE WIRING KIT CONTINUED



10mm
SOCKET

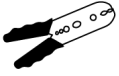

STRIPPER/
CRIMPING
TOOL

33. Locate the ground stud in the rear passenger side cargo area. Trim white ground wire so it will reach stud without excess wire. Crimp supplied fork terminal to the ground wire with a crimping tool. Loosen the ground stud and secure the fork to the terminal.

NOTICE: Loosen ground stud just enough to install fork terminal, so vehicle wiring does not lose ground.



USE A 10mm SOCKET TO ATTACH
GROUND WIRE



10MM
SOCKET

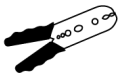

STRIPPER/
CRIMPING
TOOL

34. Locate the fuse holder supplied in the wiring kit box. Remove the fuse from fuse holder. Trim excess wire length. Crimp fuse lead to power wire. Connect fuse ring terminal to the positive battery terminal (+).



USE A 10mm SOCKET TO ATTACH TO
BATTERY

35. Secure all loose wires in the battery compartment and replace the battery cover.



Skip to Step 44 to complete installation.



INSTALL **ACTIVE** WIRING KIT

36. Locate the CAN Bus connector in the rear passenger side cargo area. It is normally taped to the vehicle wire harness as shown. Plug the active wiring harness CAN Bus connector into the vehicle CAN Bus connector.



10mm
SOCKET

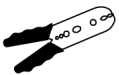

STRIPPER/
CRIMPING
TOOL

37. Locate the ground stud in the rear passenger side cargo area and the grounding ring on the active wiring harness. Carefully remove the ground stud and at the same time, keep the wires grounded here in continuous contact with the stud. Place the ground ring connector over the stud. Replace the nut and tighten.

NOTICE: Do not allow vehicle wiring to lose ground contact.



T30 TORX

38. Use a T30 Torx to remove the fuse panel. Behind the fuse panel is a 26 pin connector. Unclip the "lock clip", then push forward to release connector and unplug.



INSTALL **ACTIVE** WIRING KIT CONTINUED



39. With the 26 pin connector removed, use a 90 degree pick tool to unclip the outer housing. Slide the outer housing off of the 26 pin connector.

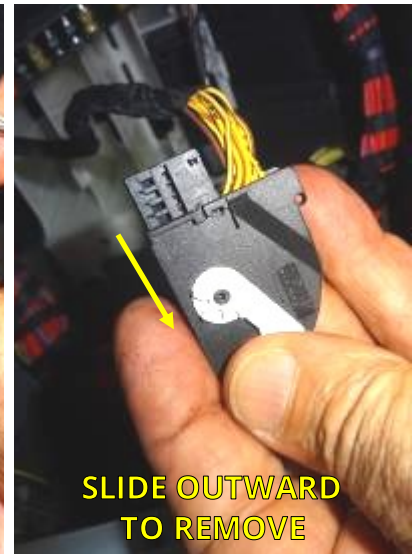

40. On the 26 pin connector, observe the number markings indicating the number for each pin slot. Locate pin slot 8 and slot 21 (marking location may help). Insert the yellow with red stripe active wiring harness wire into slot 8 and the yellow with brown stripe wire into slot 21. Push the wires firmly into the slot until seated.

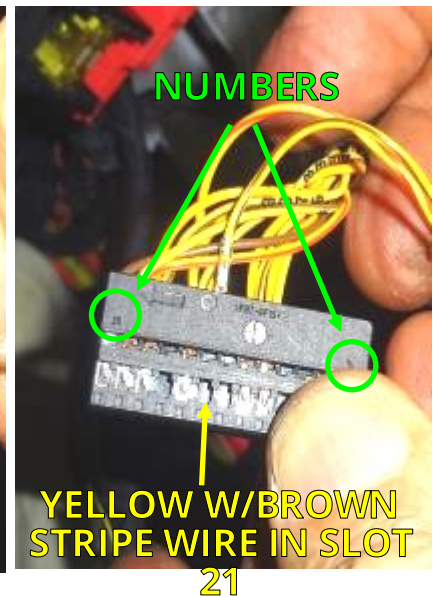
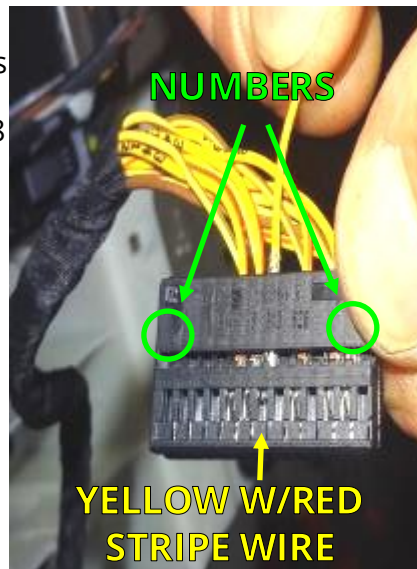

41. Replace the connector housing and plug the connector back into its original slot behind the fuse panel. Lock the connector in position with the lock clip.

42. In the active wiring kit box locate the BMW control module. Plug the (24) pin connector into the "A" slot and lock it with the lock clip. Plug the (6) pin connector into the "B" slot, and the (10) pin connector into the "C" slot. Next, place the control module into the slot shown in the fuse panel.

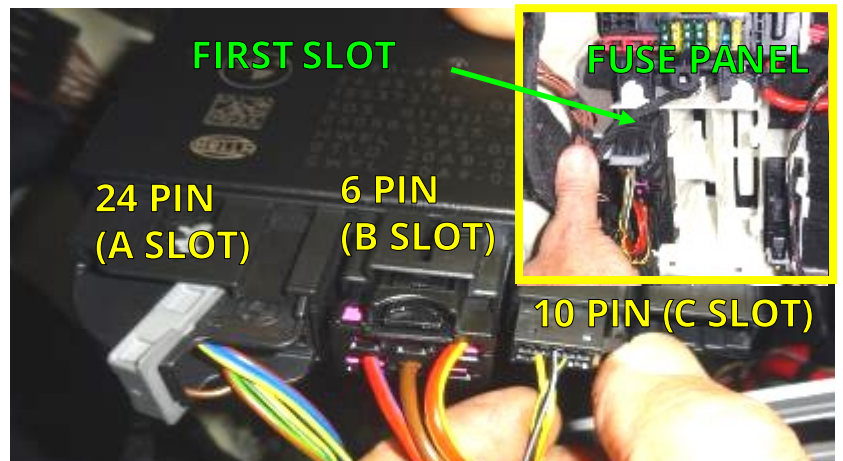

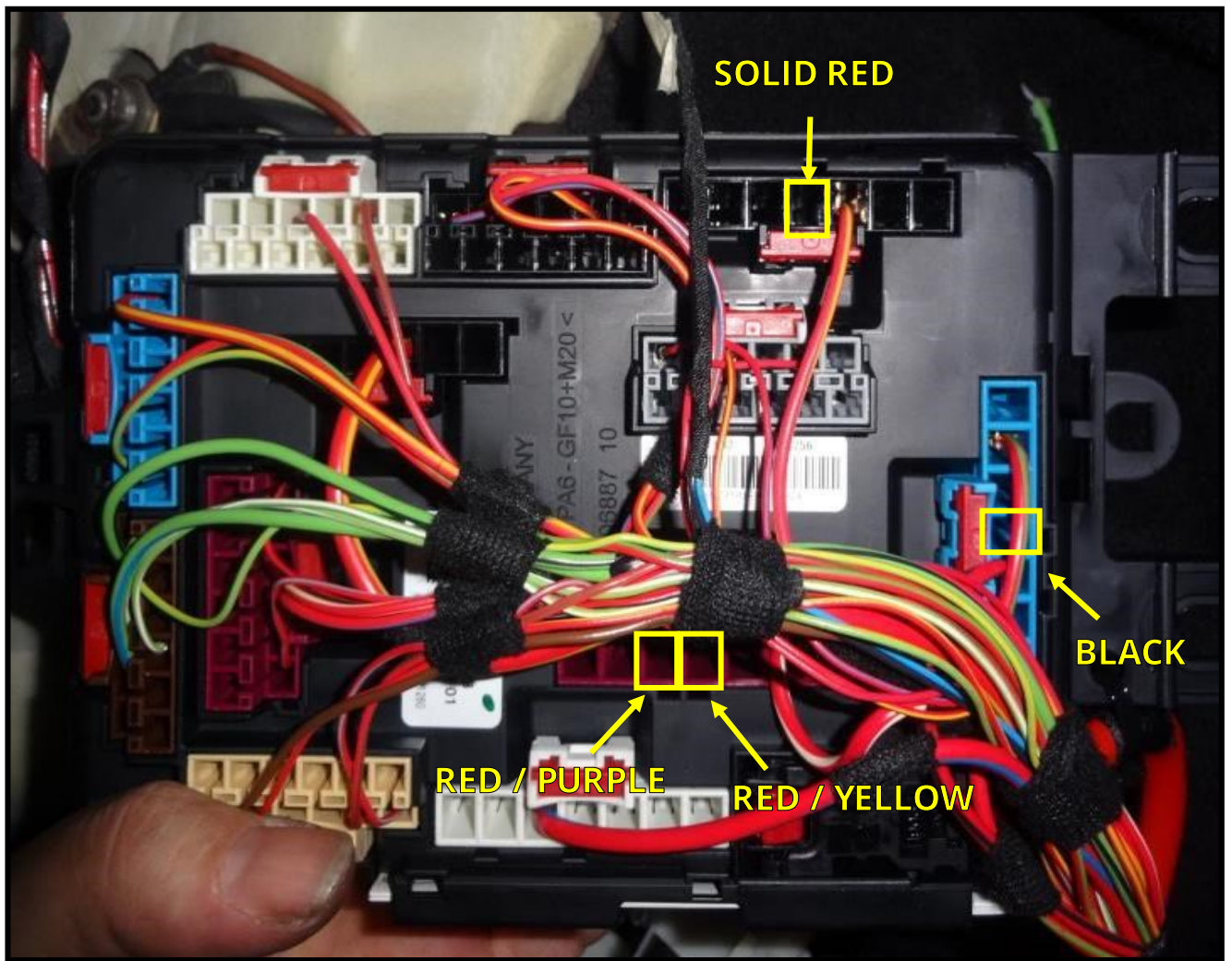

43. Carefully turn the fuse panel around to expose terminal slots. Insert spring clips into the terminal strip slots with wire colors as follows:

- **Black** - Center slot, on the indicated blue strip
- **Red** - Center slot, on the indicated black strip, in the top right corner (above grey strip)
- **Red/Purple** - Third from left slot, on the indicated center purple strip
- **Red/Yellow** - Fourth from left slot, on the same purple strip (next to Red/Purple)

Note: Verify the corresponding fuses are firmly in place. Sometimes inserting the spring clips will dislodge fuses on opposite side of fuse panel.

WIRE 7-WAY PLUG



PHILLIPS HEAD
SCREWDRIVER

44. Locate the 7-way housing. Use a screwdriver to loosen (2) screws. Remove 7-way round terminal block. Place the mounting bracket onto the 7-way housing as shown. Use a screwdriver to loosen the set screw at the bottom of the 7-way housing. Route output side wires of the wiring harness through the 7-way housing.

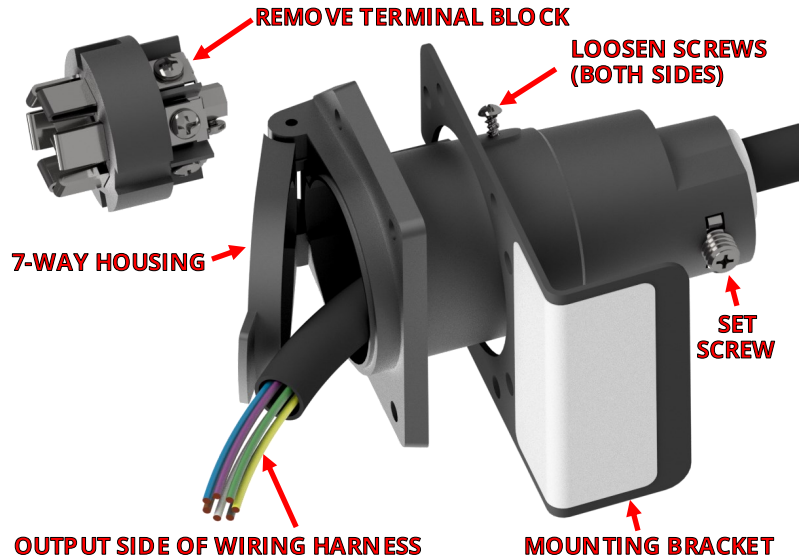

Please follow instructions below very carefully.
Incorrect wiring of the 7-way receptacle causes the vast majority of wiring problems.



PHILLIPS HEAD
SCREWDRIVER

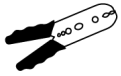

STRIPPER/
CRIMPING
TOOL

45. Locate the slot keyway. Starting from the keyway going **clockwise**, attach the wires as follows:

- Blue
- Green
- Black
- Brown
- Yellow
- White
- Purple (middle)

NOTICE: Markings on the receptacle may not match the correct wire configuration. Please disregard and follow the instruction above.

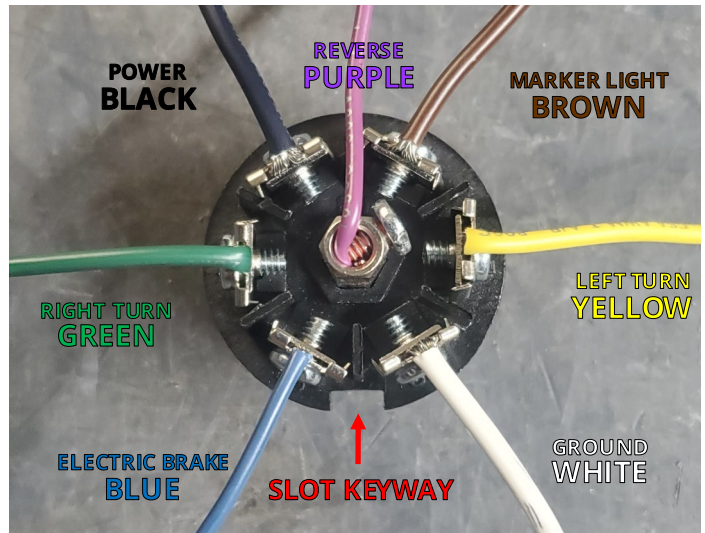

TEST 7-WAY HARNESS WIRING



PHILLIPS HEAD
SCREWDRIVER



MULTIMETER

46. Put the 7-way receptacle back together. While everything is still accessible, you should test the wiring to make sure everything is connected properly and in working order. **If installing the passive tow kit, replace the 20 Amp fuse into the fuse holder located near the battery.**

NOTICE: Most **Active** harness installations will require programming before testing can be completed. Testing Active wiring harness installations with a multimeter or LED tester may not work. Some vehicles may need to "sense" the current being used by the plug to function. After programming is complete, use an incandescent light testing device or trailer to test in these specific cases.

NOTE: Taillights will need to be temporarily plugged in during testing.

- Start by connecting the multimeter negative probe to the ground blade on the 7-way receptacle.
- Next, connect the multimeter positive probe to the power blade on the 7-way receptacle and check for 12 volts.
- Once that is confirmed, move the positive probe to the left turn blade on the 7-way receptacle and check for 12 volts when the vehicle left turn blinker is active. You should see it pulse.
- Next, move the positive probe to the right turn blade and check for 12 volts when the right turn blinker is active. You should see it pulse.
- Next, move the positive probe to the marker/taillights. With the vehicle lights on you should see 12 volts constant.
- Lastly, with the brake depressed, move the positive probe to the left turn blade where you should see 12 volts constant. Move the probe to the right turn blade where you should also see 12 volts constant.

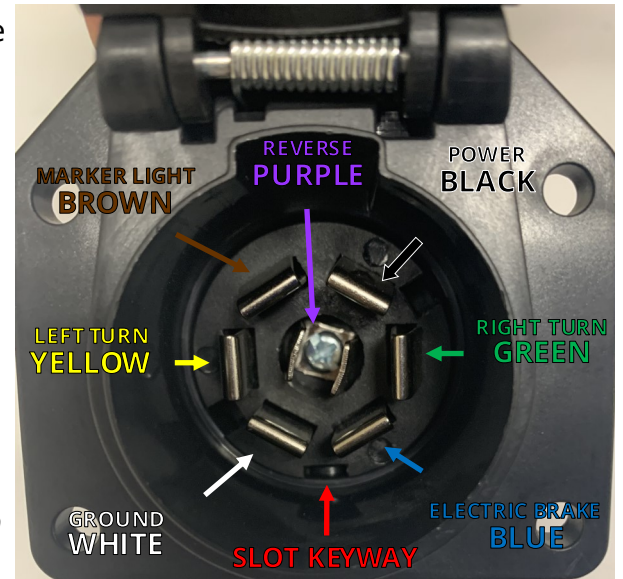

PHILLIPS HEAD
SCREWDRIVER

47. Attach the mounting bracket and 7-way housing to the stealth hitch frame as shown. Secure harness to Stealth hitch frame with cable ties.

48. Secure all wires and wiring components. Use the remaining cable ties to secure wiring so that it is not loose and will not interfere with replacement of the fascia. Wiring should not be visible once the vehicle is reassembled.

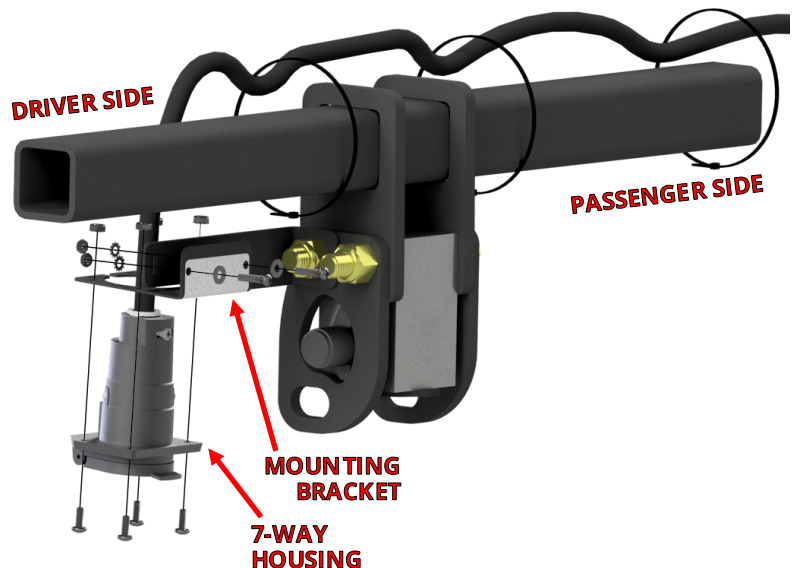

49. If installing the passive tow kit, use the provided adhesive foam strips to secure the control module to an inside body panel. Replace the grommet removed earlier on the rear passenger side of the vehicle. Use silicone to waterproof the grommet.

REINSTALL VEHICLE COMPONENTS



50. Reattach and secure the fascia, taillights, and other vehicle components in reverse order. Refer to Steps 1-15.

NOTICE: Remember to plug in the sensor plug in Step 15 before reinstalling the fascia.

NOTE: Make sure to have all (4) clips under the clip guides before you push the fascia in, see Step 14.

NOTE: Replace plastic rivets in the wheel well with supplied plastic rivets, see Step 6.



FINAL VEHICLE EXAMINATION

51. Examine the body panels to ensure that they are in a pre-installation condition. Test the electronic functions of the vehicle. Correct any inconsistencies.
52. Ensure that hitch components work properly.
 - **Verify that the lock works correctly.** Push in the safety lock on the latch block then unlock with key. The lock should slide back out with the key when unlocked.
 - **Verify that each accessory can be installed correctly.** Use the following steps to install and remove each accessory that will be used with the hitch. (*Rack Receiver* and *Ball Mount* if purchased.)
 1. Prepare latching mechanism. Turn handle clockwise if needed.
 2. Firmly insert "post" of accessory into latch block until handle releases indicating that the accessory is latched.
 3. Push in the safety locking pin until it fully engages. The locking pin prevents the handle from turning when pushed in, and confirms that the block is securely latched onto the accessory. The safety locking pin will not depress if the accessory is not fully latched.
 4. Use key to release safety locking pin.
 5. While holding on to the accessory, rotate handle clockwise to release and remove the accessory.
 - **Verify that no part of the accessories come into contact with the body of the vehicle.**

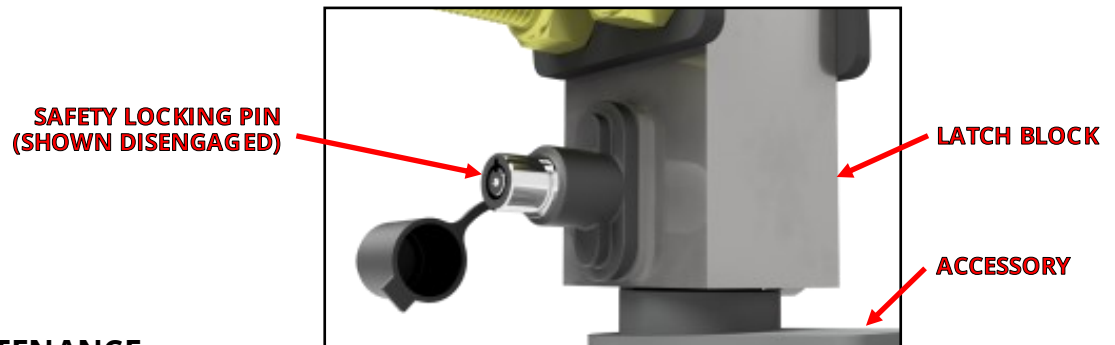

PRODUCT USE AND MAINTENANCE

NOTICE: If the hitch is being installed by a professional, the installer is responsible for training the end user in the use and maintenance of the product.

- **Accessory installation procedure:**
 1. Prepare latching mechanism. Turn handle clockwise if needed.
 2. Firmly insert "post" of accessory into latch block until handle spins counter-clockwise indicating that the accessory is latched.
 3. Always depress the safety locking pin and check that it has fully engaged.
- **Never use any accessory with the safety lock disengaged.** Until the safety locking pin is engaged, the handle is able to turn. A fully engaged safety locking pin is confirmation that the accessory is properly latched into the latch block.
- **Never use the rack receiver for towing.** The rack receiver accessory is only to be used with payload carrying products, such as bike racks or luggage racks.
- **Before each use, give the post of the accessory a light coating of lithium based grease.**
- **Before each use, inspect the hitch to ensure that all bolted connections are secure and that no cracks or damage are present.** Do not tow with the hitch if cracks or damage outside of normal wear is found.
- **Remove the Stealth accessories from the latch block after each use.** Do not leave accessories plugged in for extended periods of time.