

HITCH INSTALLATION INSTRUCTIONS

MAKE: BMW **YEARS:** 2010 - 2013 **MODEL/TRIM:** X5M HP (E70 CHASSIS)

www.stealthhitches.com 833-694-4824

RACK RECEIVER KIT#: **SHR31029**

TOW KIT#: **SHT25014A**



2" RACK RECEIVER MAXIMUM PAYLOAD: 600 LBS
MAXIMUM TOW RATING: 6000 LBS
MAXIMUM TONGUE WEIGHT: 600 LBS

UNDER VEHICLE TRIMMING: **INSTALLATION TIME:**

HEAT SHIELD: **NO** RACK ONLY: 2 HOURS
 FASCIA: **YES** RACK + TOW: 2.5 HOURS
 GRAVEL GUARD TRIMMING: **NO**



READ ALL INSTRUCTION WARNINGS AND LABELS



NO WELDING, METAL DRILLING OR VISIBLE TRIMMING REQUIRED

PARTS SUPPLIED WITH RACK RECEIVER KIT:

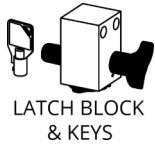

LATCH BLOCK & KEYS

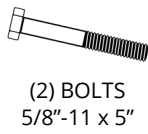

(2) BOLTS
5/8"-11 x 5"



(2) 5/8"
NYLOCK NUTS

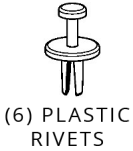

(6) PLASTIC
RIVETS



2" RACK
RECEIVER

ADDITIONAL PARTS FOR TOW KIT:

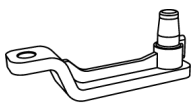

BALL MOUNT
5" RISE, SHORT



CHAIN HOOKS



2" BALL

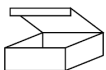

ACTIVE WIRING
HARNESS KIT BOX

TOOLS REQUIRED:



15/16" OPEN
END WRENCH



18mm DEEP WELL,
8mm, & 15/16"
SOCKETS

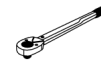

TORQUE
WRENCH

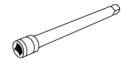

SOCKET
EXTENSION



SAFETY GLASSES



RATCHET



FLASHLIGHT



PLASTIC
PRY TOOLS



5/16"
ALLEN WRENCH



90 DEGREE
PICK



RAZOR KNIFE



FILE



PAINTER'S TAPE



DREMEL TOOL

ADDITIONAL TOOLS FOR ACTIVE TOW KIT:



T30 TORX



STRIPPER/
CRIMPING
TOOL



PHILLIPS HEAD
SCREWDRIVER



10mm
SOCKET



MULTIMETER



PLIERS
(OPTIONAL)

<THESE INSTRUCTIONS MUST BE GIVEN TO THE END USER>

NOTICE: Installation of Stealth products may or may not require the addition of a wiring harness to the vehicle.

- The Rack Receiver only product does not require adding a wiring harness.
- The Rack Receiver plus Tow Kit requires the addition a wiring harness that is compatible with the vehicle's wiring. Depending on the vehicle, the harness will be one of two types, "Active" or "Passive." The wiring section of the instructions will indicate which wiring harness style is being used and how to install it.
- The **Active Harness** plugs into the vehicle's existing wiring so that the vehicle's computer can communicate with the trailer harness wiring and receive information from it. This allows certain functions such as cameras or backup alarms to continue to operate as designed. The active harness requires reprogramming of the vehicle's computer before the trailer wiring can be used. ***This programming must be taken into account when planning the timing of the Stealth product install. The programming process should be started before the installation of the parts. Please allow at least a week to make programming arrangements.***
- The **Passive Harness** is independent of the vehicle's computer and communication system. This type of harness gets its power directly from the battery. It "reads" the output of the vehicle's lights and translates that to the trailer without being connected to the computer.









INSTALLATION NOTE: In most instances, these instructions will only outline disassembly of vehicle components. Re-installation of components will require the installer to retain vehicle hardware and work through disassembly instructions in reverse order. When installation is complete, double check that all vehicle components have been replaced and are secured.

IMPORTANT SAFETY NOTICE FOR STEALTH HITCH INSTALLERS AND CUSTOMERS.

Read all installation and operating instructions along with all labels before installing or using this product. Do not perform any installation or towing procedures without fully understanding the correct tools and actions for all steps. Call for support if needed.

WARNING

Failure to comply with the safety information in these instructions could result in serious injury or death.

-  Do not modify this product in any manner. Doing so could alter its integrity and lead to a loss of attachment between the trailer and the tow vehicle.
-  Adding Stealth hitch components to the chassis of any vehicle can be hazardous. There is potential for unexpected combustion of fuel, electric shock, burns, shifting or falling of unstable vehicle, damage to vehicle, injury from tool usage and many other hazards. This installation must be completed by someone who is aware of the hazards involved. This person must be knowledgeable of proper safety procedures for a vehicle modification of this nature, and for usage of the equipment required to perform the installation.
-  Without proper knowledge, towing can be a dangerous activity. Understand all the risks involved with towing before proceeding. For information on towing safety, see "**The Trailer Handbook: A Guide to Understanding Trailer and Towing Safety**" from the National Association of Trailer Manufacturers, www.NATM.com and your trailer and tow vehicle manufacturer's owner's manual.
-  Do not exceed tow or tongue rating of coupler, tow or tongue rating of hitch, or tow or weight ratings of tow vehicle or trailer. See vehicle and trailer manufacturer information for ratings. Exceeding these ratings may cause damage to towing components or loss of attachment between the trailer and vehicle.
-  While installation is being performed, check for signs of damage or excessive corrosion. Do not install hitch components over vehicle parts that are broken or have compromised structural integrity.
-  This product was designed to fit vehicles in their original, "as manufactured" condition. Compatibility with vehicles having replacement parts, or other modifications is not guaranteed. Inspect vehicle for modifications before installation of this product.
-  Some accessories, like the rack receiver, are not rated for towing. Do not use any accessories without proper knowledge of their use.
-  A visual inspection of the hitch should be performed before each use. Regularly check that all connections are secure, including those that secure the hitch to the vehicle. Check for cracks or damage to the hitch. Do not use the hitch if cracks or damage outside of normal wear is found. Using a hitch that has unsecure connections and/or cracks or damage could result in damage to the tow vehicle, trailer, towing components and loss of attachment between the tow vehicle and trailer.
-  Stealth hitches are not compatible with any weight distribution or sway control products. Adding additional products to the trailer or chassis which modifies the function of the Stealth hitch may cause hitch failure.

NOTICE: Installation of hitch requires removal of vehicle parts and interaction with vehicular electronics. Before installation, check the condition of body panels and note any locations where panels are not flush. Check the electronic functions of the vehicle, such as: headlights, taillights, turn signals, cameras, backup sensors, Parking Distance Controller (PDC), foot activated cargo access, etc. It is the responsibility of the installer to restore the fit and function of the vehicle

NOTICE: If installing an active wiring harness, your vehicle must be programmed. Arrangements can be made with Code My Car (585-496-4648). Please allow at least a week to make programming arrangements. Programming will require your vehicle to be connected to a computer and an internet connection. **Note:** A programming code is affixed to the control module and the programming cord which will be needed when contacting Code My Car. Additional programming changes may be available at time of programming. Arrangements can be made when contacting Code My Car.

GAIN ACCESS TO MOUNTING AREA

1. Open vehicle cargo area and remove driver and passenger side panels for access to rear of the taillights.



2. Unplug the wiring harness from both taillights.



GAIN ACCESS TO MOUNTING AREA CONTINUED



8mm
SOCKET

3. Use a socket to remove (3) nuts securing each of the taillights.



PLASTIC
PRY TOOLS

4. Slide the taillights toward the rear of the vehicle, to remove. A plastic pry tool can be used, if necessary.



PLASTIC
PRY TOOLS



90 DEGREE
PICK

5. Locate the rivets inside the rear wheel wells. Use a 90 degree pick or a pry tool to remove (3) most rearward plastic rivets. The rivets secure the wheel well trim to the vehicle.

NOTE: Make sure not to damage the wheel well trim piece.

NOTE: Replacement plastic rivets are supplied.



GAIN ACCESS TO MOUNTING AREA CONTINUED



- To allow partial removal of the rear wheel well trim, clips (3) will need to be disconnected. Apply outward pressure on wheel well trim. Start with the bottom clip and work up. Push down on clip to disconnect. Use plastic pry tools on hard to reach clips.



8mm
SOCKET

- Behind the rear wheel well trim is (1) screw holding the fascia. Pull the trim away from vehicle to expose the screw. Use a socket to remove screw. Repeat Steps 2-7 on other side of vehicle.



PAINTER'S TAPE

NOTE: To protect the trim from being scratched during the removal or replacement, cover it with painter's tape or something similar.



- Remove the two reflectors directly below each taillight location. Each reflector is clipped into vehicle in three places. On some vehicles, the center clip is accessible under the vehicle. Push upward and to the rear of the vehicle to disengage this clip. If the clip is not easily accessible pry the reflector with a plastic pry tool. Pry from the inside to the outside of the vehicle.

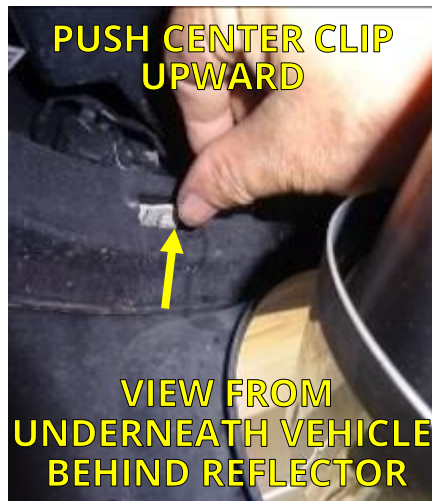

GAIN ACCESS TO MOUNTING AREA CONTINUED



8mm
SOCKET

9. With the reflector removed, a screw will be exposed. Use a socket to remove screw.

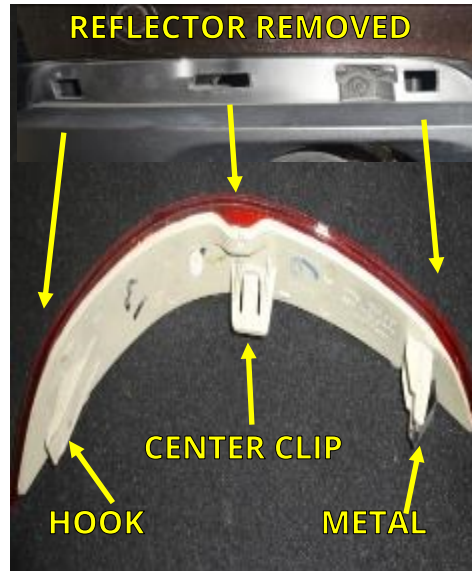

USE 8mm SOCKET
TO REMOVE
SCREW



8mm
SOCKET

10. Underneath the vehicle, use a socket to remove (6) screws from the bottom edge of the fascia.



PLASTIC
PRY TOOLS

11. The fascia is clipped to the vehicle body directly behind the wheel wells. Pull outward on the fascia to expose the first clip in the seam. With a plastic pry tool, push down on the exposed clip to disconnect. Continue to pull outward on the fascia and disconnect clips as they are exposed. The last two clips will be in the bottom of the light housing. Repeat on other side of vehicle.

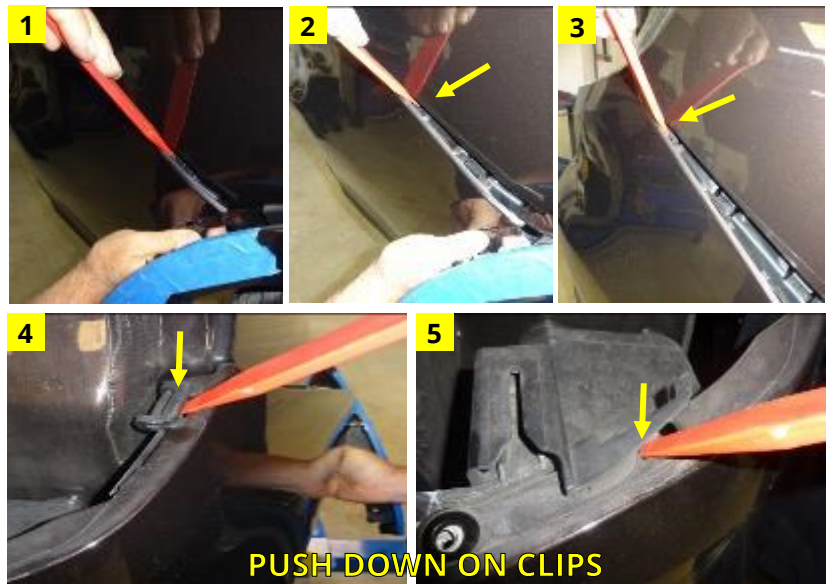

GAIN ACCESS TO MOUNTING AREA CONTINUED



12. While positioned behind the center of the vehicle, locate the (4) remaining clips holding the fascia. Before disconnecting each clip, put rearward pressure on the fascia. Starting from one side, use an Allen wrench to push down and disconnect each clip.

NOTE: Use caution when pulling the fascia rearward. The fascia is still connected to the vehicle by a wire harness.

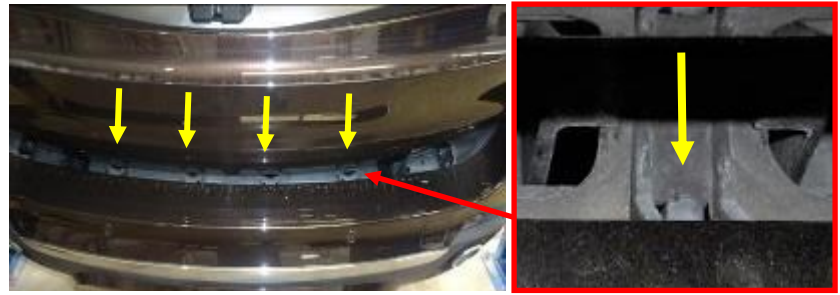

USE 5/16" ALLEN WRENCH TO PUSH DOWN ON CLIPS



PULL FASCIA REARWARD



13. This step requires a partner. Pull the fascia rearward enough to access the PDC sensor plug on the passenger side. Press down on the clips to unplug the PDC sensor. In some cases a 90 degree pick tool will be needed to disconnect the sensor plug. Remove the fascia completely.

NOTICE: Carefully remove the fascia and place on a blanket or pad.



PASSENGER
SIDE

SQUEEZE RELEASE
CLIP



14. On both sides of the vehicle, use a socket to remove (1) screw. Unclip the two clips from the fascia support, to get access to the factory nuts securing the reinforcement beam.



USE 8mm SOCKET TO REMOVE THE
SCREW

SQUEEZE THE TWO CLIPS TO RELEASE

GAIN ACCESS TO MOUNTING AREA CONTINUED



18mm
DEEP WELL
SOCKET



PLASTIC
PRY TOOLS

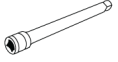

SOCKET
EXTENSION



RAZOR KNIFE

15. Some vehicles have plastic stud covers on the nuts that secure the factory reinforcement beam. Unscrew stud covers and **save for later reinstallation.**

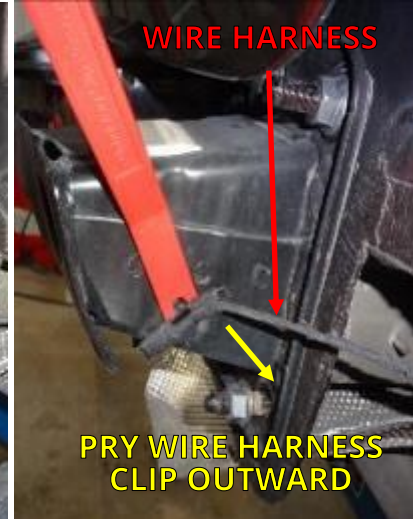

16. Remove the wire harness clip from the factory reinforcement beam, on the passenger side.

17. If you removed plastic stud covers from your vehicle, trim 1/4" off the open end. This will accommodate the thicker Stealth hitch frame.



18. Use a socket to remove the (8) nuts that secure the factory reinforcement beam to the vehicle. **Save the nuts for the hitch installation. Discard the factory reinforcement beam.**



INSTALL STEALTH HITCH FRAME



18mm
DEEP WELL
SOCKET



TORQUE
WRENCH

19. Install the Stealth hitch frame onto the vehicle studs. Center the hitch frame. Use a torque wrench to tighten the factory nuts to 85 ft.-lbs. If removed earlier, replace trimmed plastic stud covers.

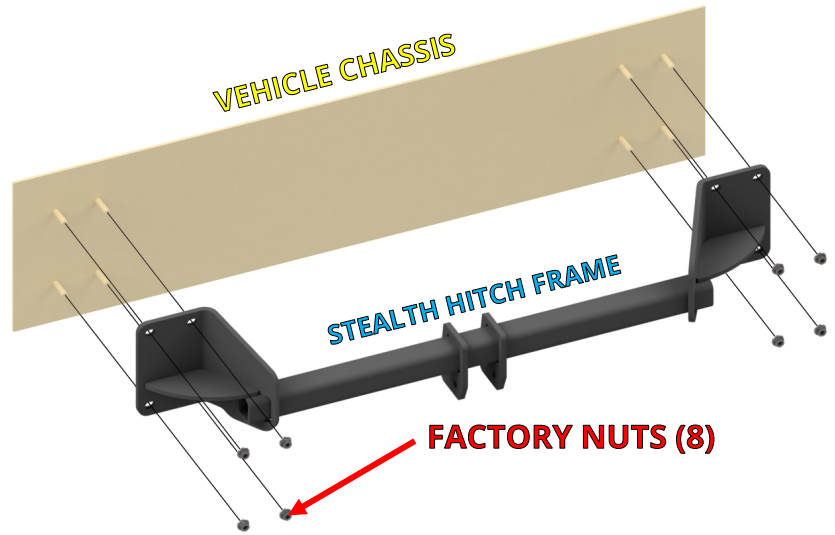

USE AN 18mm SOCKET TO INSTALL (8) NUTS

MOUNT LATCH BLOCK



15/16"
SOCKET



15/16" OPEN
END WRENCH



TORQUE
WRENCH

20. Installation of the latch block varies depending on which kit you are installing.

- **Rack Receiver Kit:** Install the latch block with (2) 5/8"-11 x 5" bolts and (2) 5/8" nylock nuts. Tighten each bolt to 150 ft.-lbs.
- **Tow Kit:** Retrieve Z-bracket from wiring harness kit box. Install the latch block, (2) chain hooks, and Z-bracket with (2) 5/8"-11 x 5" bolts and (2) 5/8" nylock nuts. Tighten each bolt to 150 ft.-lbs.

NOTICE: Keys are packaged within the latch block, remove keys and store in safe location.

RACK RECEIVER KIT INSTALL



TOW KIT INSTALL

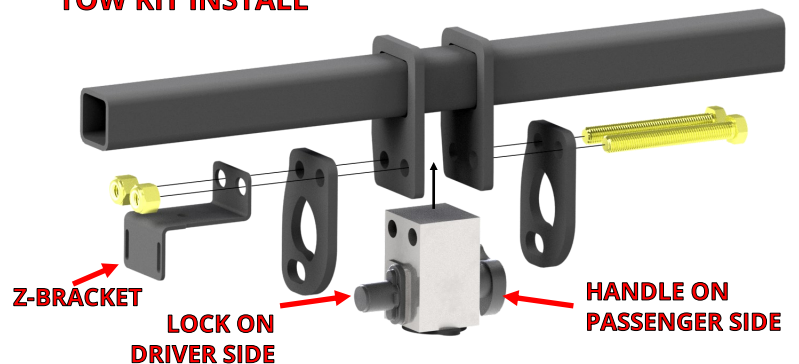

IF INSTALLING A RACK RECEIVER KIT, SKIP TO STEP 43.
IF INSTALLING A TOW KIT, CONTINUE TO STEP 21.

INSTALL WIRING KIT

#	DESCRIPTION	QTY
1	BMW TOW WIRING HARNESS	1
2	BMW TOW CONTROL MODULE	1
3	PROGRAMMING CABLE	1
4	WIRING COMPONENT PACKAGE <ul style="list-style-type: none"> • 8" CABLE TIE (6) • FUSE (1 20AMP, 2 25AMP, 1 30AMP) • SCREWS (4) *NOT USED* • CLAMP-ON CONNECTOR (1) 	1
5	5/8" LONG PHILLIPS SCREWS	6
6	#10 LOCK NUT	6
7	PLASTIC RIVET	1
8	Z-BRACKET	1
9	MOUNTING BRACKET	1
10	7-POLE HOUSING	6
11	CABLE TIE - 14"	2
12	7-POLE TO 4-POLE ADAPTER	1



21. Locate the wiring kit box. Review the contents of the box against the list above to check for missing components. **The active wiring kit** uses a BMW computer control module to manage the functions of the trailer lighting. The module must be “programmed” before it will be functional. The module will connect to the vehicle through an included wire harness. The harness has an “input” side that receives power and signals from the vehicle’s electronic systems. The “output” side of the harness delivers this information to the 7-way plug. The harness and computer module installation are outlined in the next steps.

NOTICE: Do not allow electrical system to become disconnected from power or ground. Doing so may interrupt electrical systems.

BMW TOW WIRING HARNESS

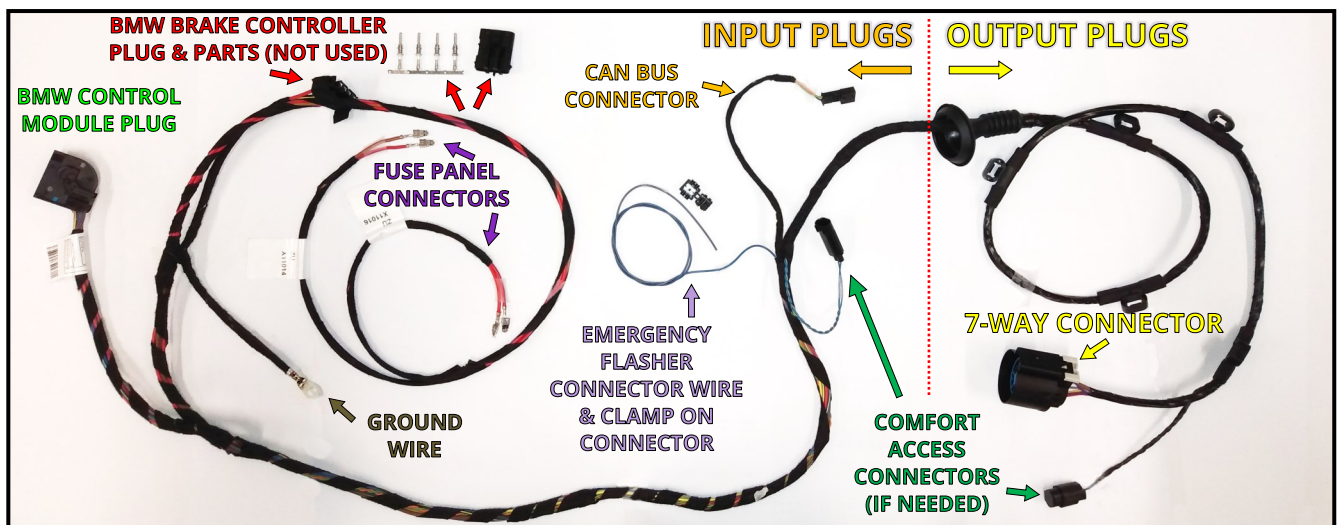

INSTALL WIRING KIT CONTINUED

22. Gain access to the electrical panel on the passenger side. If vehicle has a passenger side storage bin, remove it by removing 1 rivet. Place the wiring harness in this area.

NOTE: A replacement plastic rivet is supplied.

23. Locate the two wiring access holes directly above the exhaust on the passenger side. To allow the wiring harness to reach the 7-way plug it must go through the inner access hole. If both holes are already in use, see Steps 24-26 for possible rerouting tips. If only a grommet, is present remove the grommet and skip to Step 27.



24. If the inner access hole has a vacuum hose passing through it, reroute the vacuum hose through the grommet in the outer access hole as follows:

- A. Detach the hose (1) from the inline coupling. Remove the grommet from the hose.
- B. Pull the grommet in the outer access hole (1) to the exterior of the vehicle. Reroute the hose (2) through outer access hole.
- C. Use a fish wire to pull the hose (2) through the outer grommet, alongside existing wiring.
- D. Reseal the grommet to the hose and wires with electrical tape. Seat the grommet in the outer access hole. Reconnect the hose to the inline coupling.

A

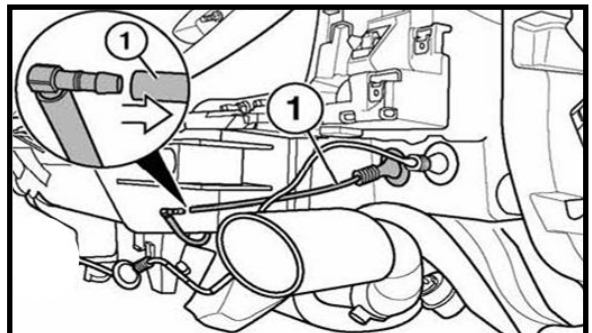

B

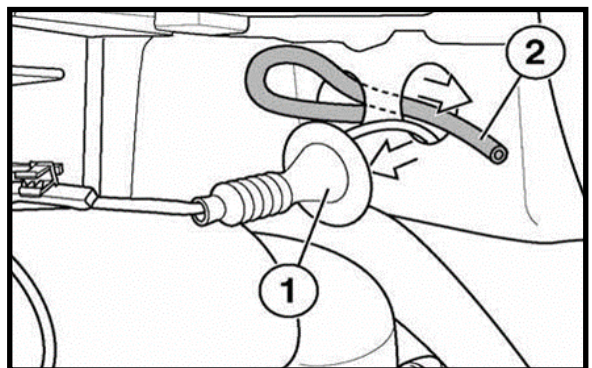

C

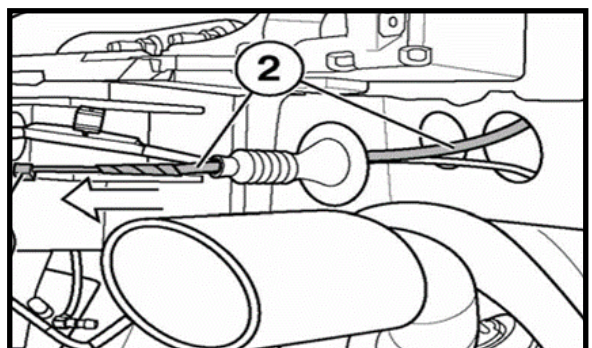

INSTALL WIRING KIT CONTINUED

25. If the inner access hole has wiring for the Comfort Access antenna passing through it, substitute with the Comfort Access wiring that is included on the wiring harness as follows:

A

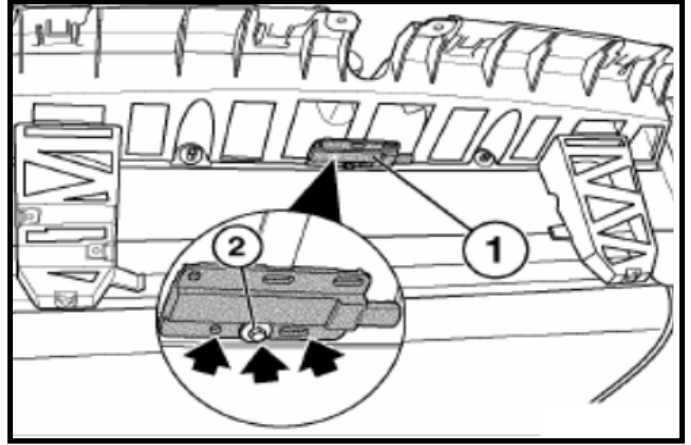

- A. Disconnect the wire from the exterior Comfort Access antenna (1). It may be necessary to loosen or remove the mounting screw (2) to disconnect the wire.
- B. Pull the disconnected antenna wire and its grommet into the interior of the vehicle.
- C. When hitch wiring harness is installed, this connector will be plugged into mating connection on the hitch wiring harness.
- D. Plug the external antenna into the Comfort-Access wire on the wiring harness.



26. If the inner access hole has other wiring with large connectors passing through it, it may not be possible to feed the wire and connectors through the outer access hole grommet. It may be necessary to slit the grommet to reroute the wire as follows:

- A. Unplug the wire. Feed the wire, connector, and grommet back into the interior of the vehicle.
- B. Pull the grommet in the outer access hole to the exterior of the vehicle. Carefully cut a slit in the grommet.
- C. Feed the wire and connectors to the exterior of the vehicle through the outer access hole.
- D. Place the wire in the slit. Reseat the grommet and seal with silicone when wiring install is finished. Plug in the wire.

INSTALL WIRING KIT CONTINUED

27. Guide the input wires of the wiring harness through the inner access hole to the interior of the vehicle. Make sure the grommet is properly seated in the hole.

NOTE: It may be necessary to move the locking clip on the BMW control module plug to pass it through the inner access hole.



28. Locate the CAN Bus connector in the rear passenger side cargo area. It is normally taped to the vehicle wire harness as shown. Plug the wiring harness CAN Bus connector into the vehicle CAN Bus connector.

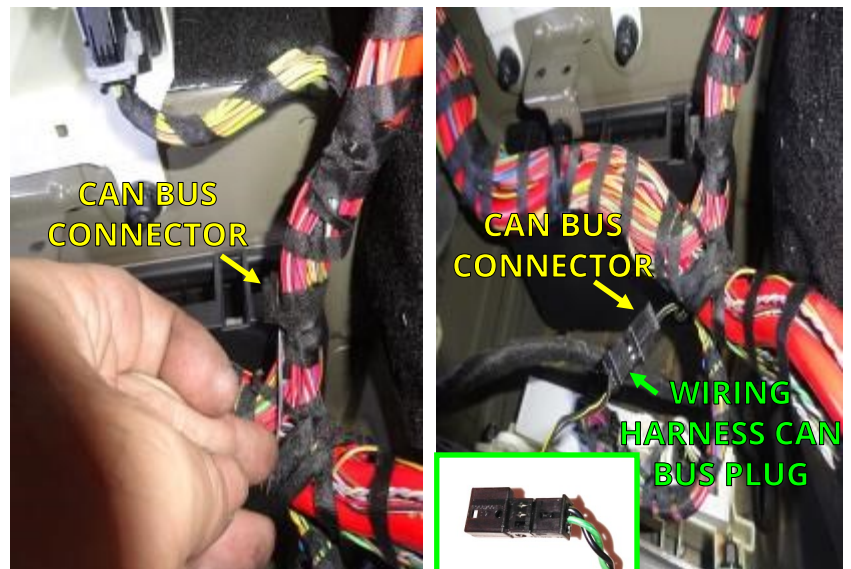

29. In the active wiring kit box locate the BMW control module. Plug the (16) pin connector into the module and lock it with the lock clip. Place the control module into an available slot below the fuse panel.

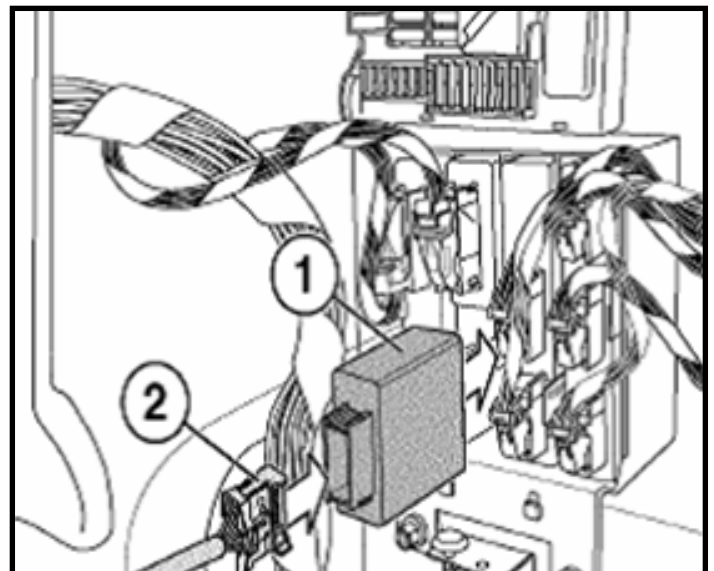

INSTALL WIRING KIT CONTINUED

Optional preservation of emergency flashers on trailer when vehicle is off and locked:

When the ignition is off and the key fob is not present, the vehicle will automatically put CAN bus modules such as the trailer-control module into a sleep mode after several minutes to prevent battery drain. This disables all trailer lights. In some conditions, it may be desirable for the trailer hazard lights to remain operational for an extended period of time with the vehicle off, doors locked, and key fob not present – such as when leaving the vehicle unattended in a roadside emergency with its hazard lights on.

For the trailer hazard lights to remain operational under such conditions, a direct (non-CAN bus) connection to a flashing turn signal is required. If this optional connection is desired, perform Steps 28-30. If this connection is not desired, tape off the small blue/brown wire on the harness and skip to Step 31.



PLIERS



MULTIMETER

30. Route the single blue/brown wire of the wiring harness to the area behind the passenger side taillight.
31. Locate the blue/brown wire coming from the passenger taillight plug. This is the turn signal wire. Follow this wire to an area that is easily within reach of the blue/brown wire of the wiring harness.
32. Remove enough tape from the wiring bundle to gain access to the blue/brown wire. Use the supplied clamp on connector to connect the blue/brown wire of the wiring harness to the blue/brown wire of the taillight plug.



NOTE: Vehicles may have a different wire color. Verify circuit (wire color) with multimeter. Taillight will need to be temporarily plugged in to verify.



10mm
SOCKET

33. Locate the ground stud in the rear passenger side cargo area and the grounding ring on the wiring harness. Carefully remove the ground stud and at the same time, keep the wires grounded here in continuous contact with the stud. Place the ground ring connector over the stud. Replace the nut and tighten.

NOTICE: Do not allow vehicle wiring to lose ground contact.



INSTALL WIRING KIT CONTINUED



T30 TORX

34. Remove the fuse panel by using a Torx to remove (1) screw holding the fuse panel. Carefully turn the fuse panel around to access the back.



35. Locate the **Blue** connector in the upper left corner of the backside of fuse panel.

36. Locate the Red/Blue and Solid Red wiring pair on the wiring harness labeled with **X11016**. Plug the wiring pair in as follows:

- Plug the **Red/Blue** wire into pin position 1, the upper left corner, of the blue connector. This is fuse 116.
- Plug the **Solid Red** wire into pin position 3, the upper right corner, of the blue connector. This is fuse 118.

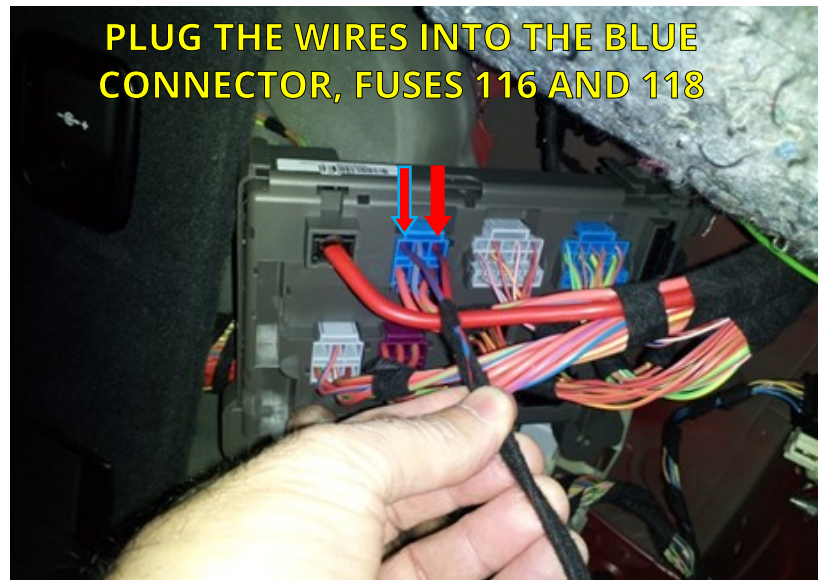

37. Locate the **Black** connector in the lower right corner of the backside of the fuse panel.

38. Locate the Red/Green and Red/Violet wiring pair on the wiring harness labeled with **X11014**. Plug the wiring pair in as follows:

- Plug the **Red/Green** wire into pin position 3, the lower right corner, of the black connector. This is fuse 144.
- Plug the **Red/Violet** wire into pin position 2, the center right directly above red/green wire, of the black connector. This is fuse 143.

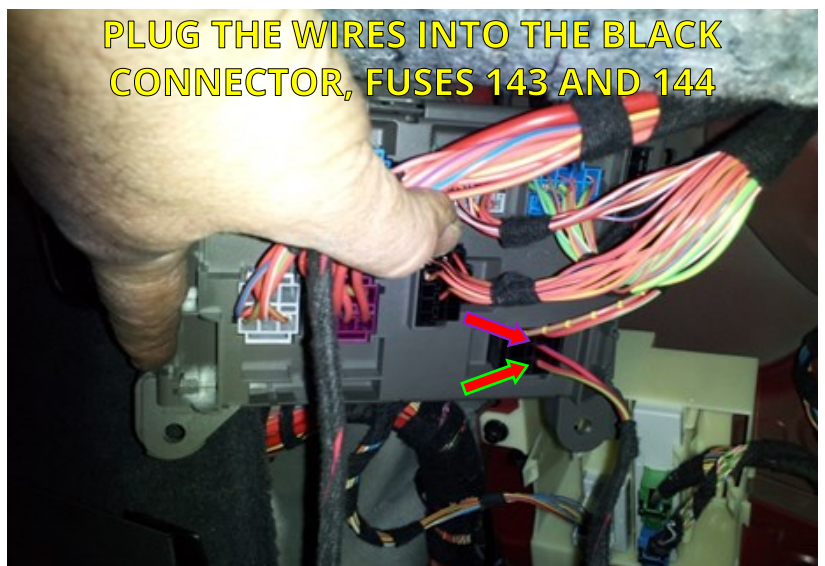

INSTALL WIRING KIT CONTINUED



PHILLIPS HEAD
SCREWDRIVER

39. Attach the mounting bracket to the Z-bracket as shown. Pass the plug of the wiring harness through the mounting bracket. Plug the cable into the 7-way housing. Attach the 7-way housing to the mounting bracket, as shown. Secure harness to Stealth hitch frame with cable ties.

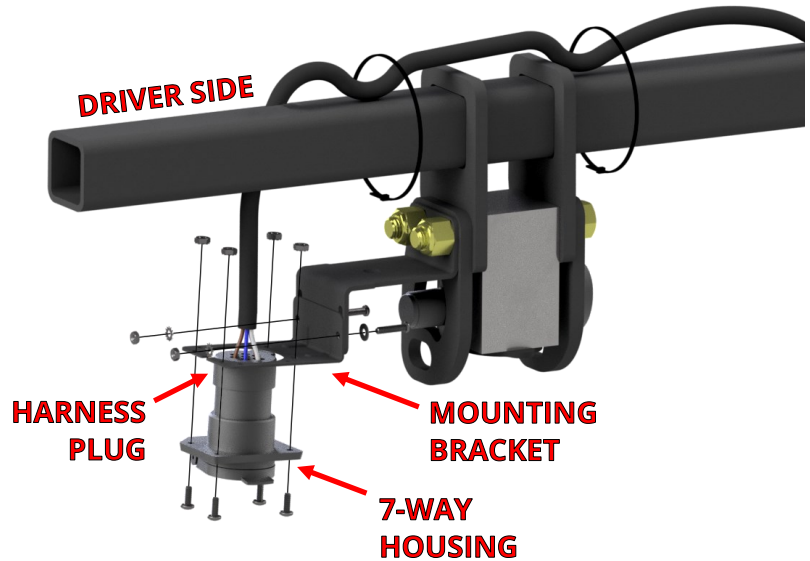

40. Turn the fuse panel back around to front. Install the 4 provided fuses as follow:

- 20 Amp fuse into position 116
- 30 Amp fuse into position 118
- 25 Amp fuse into position 143
- 25 Amp fuse into position 144

Reinstall the fuse panel.

INSTALL FUSES INTO FUSE PANEL

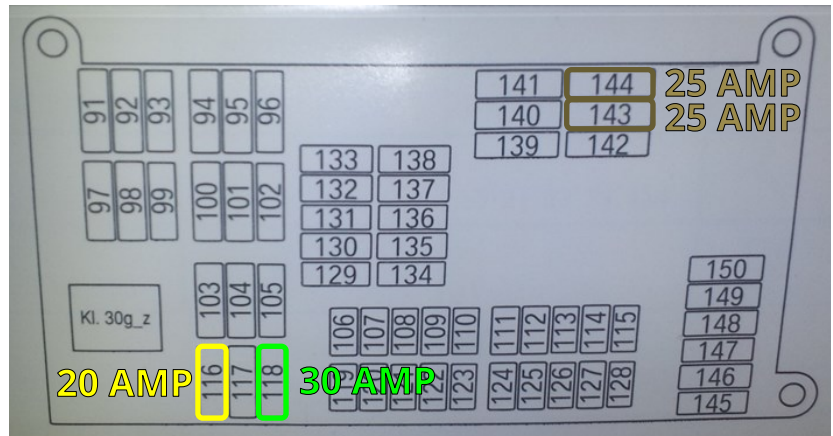

TEST 7-WAY HARNESS WIRING



PHILLIPS HEAD
SCREWDRIVER



MULTIMETER

41. Test the 7-way plug to check that everything is connected properly and in working order.

NOTICE: Due to the installed **active** harness your vehicle will have to be programmed before testing can be completed. If programming is scheduled for a later time, refer to this section to test your wiring once the programming is completed.

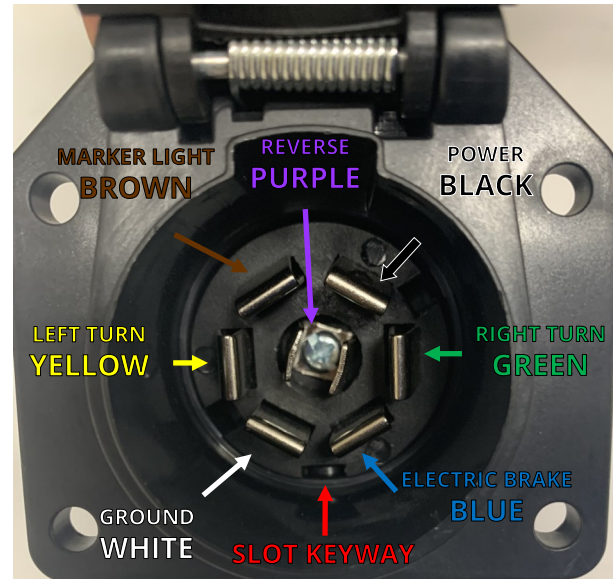

- Start by connecting the multimeter negative probe to the ground blade on the 7-way receptacle.
- Next, connect the multimeter positive probe to the power blade on the 7-way receptacle and check for 12 volts.
- Once that is confirmed, move the positive probe to the left turn blade on the 7-way receptacle and check for 12 volts when the vehicle left turn blinker is active. You should see it pulse.
- Next, move the positive probe to the right turn blade and check for 12 volts when the right turn blinker is active. You should see it pulse.
- Next, move the positive probe to the marker/taillights. With the vehicle lights on you should see 12 volts constant.
- Lastly, with the brake depressed, move the positive probe to the left turn blade where you should see 12 volts constant. Move the probe to the right turn blade where you should also see 12 volts constant.

42. Secure all wires and wiring components. Use the remaining cable ties to secure the wiring. Use the provided adhesive foam strips to secure the control module to an inside body panel. Reinstall the passenger side storage bin with provide plastic rivet, if removed. Wiring should not be visible once the vehicle is reassembled.

CUT ACCESS TO LATCH BLOCK



DREMEL TOOL



FILE

43. Trim edge of fascia, as shown, with Dremel tool. Use a file to smooth out the cut.

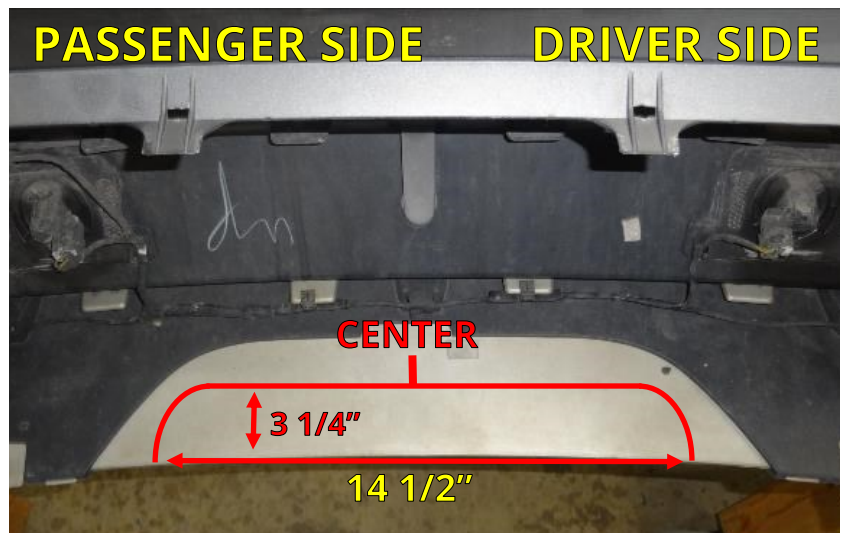

REINSTALL VEHICLE COMPONENTS

44. Replace the fascia support clips removed in Step 14. While holding the fascia close to the vehicle, plug in the PDC sensor plug. Push the fascia inward to replace.

NOTICE: Remember to plug in the sensor plug in Step 13 before reinstalling the fascia.

NOTE: Make sure to have all (4) clips under the clip guides before you push the fascia in, see Step 12.



45. Reattach and secure the taillights and other vehicle components in reverse order. Refer to Steps 1-11.

NOTE: Replace plastic rivets in the wheel well with supplied plastic rivets, see Step 5.



46. Finished view of Stealth hitch from underneath vehicle.



FINAL VEHICLE EXAMINATION

47. Examine the body panels to ensure that they are in a pre-installation condition. Test the electronic functions of the vehicle. Correct any inconsistencies.
48. Ensure that hitch components work properly.
 - **Verify that the lock works correctly.** Push in the safety lock on the latch block then unlock with key. The lock should slide back out with the key when unlocked.
 - **Verify that each accessory can be installed correctly.** Use the following steps to install and remove each accessory that will be used with the hitch. (*Rack Receiver and Ball Mount if purchased.*)
 1. Prepare latching mechanism. Turn handle clockwise if needed.
 2. Firmly insert “post” of accessory into latch block until handle releases indicating that the accessory is latched.
 3. Push in the safety locking pin until it fully engages. The locking pin prevents the handle from turning when pushed in, and confirms that the block is securely latched onto the accessory. The safety locking pin will not depress if the accessory is not fully latched.
 4. Use key to release safety locking pin.
 5. While holding on to the accessory, rotate handle clockwise to release and remove the accessory.
 - **Verify that no part of the accessories come into contact with the body of the vehicle.**

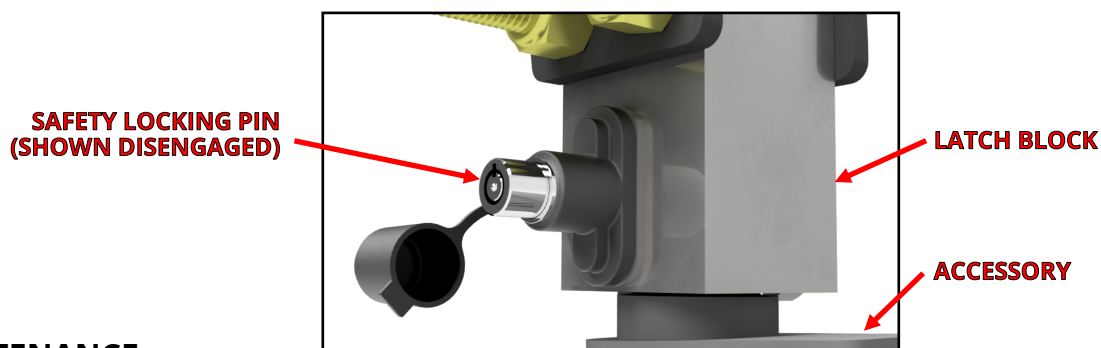

PRODUCT USE AND MAINTENANCE

NOTICE: If the hitch is being installed by a professional, the installer is responsible for training the end user in the use and maintenance of the product.

- **Accessory installation procedure:**
 1. Prepare latching mechanism. Turn handle clockwise if needed.
 2. Firmly insert “post” of accessory into latch block until handle spins counter-clockwise indicating that the accessory is latched.
 3. Always depress the safety locking pin and check that it has fully engaged.
- **Never use any accessory with the safety lock disengaged.** Until the safety locking pin is engaged, the handle is able to turn. A fully engaged safety locking pin is confirmation that the accessory is properly latched into the latch block.
- **Never use the rack receiver for towing.** The rack receiver accessory is only to be used with payload carrying products, such as bike racks or luggage racks.
- **Before each use, give the post of the accessory a light coating of lithium based grease.**
- **Before each use, inspect the hitch to ensure that all bolted connections are secure and that no cracks or damage are present.** Do not tow with the hitch if cracks or damage outside of normal wear is found.
- **Remove the Stealth accessories from the latch block after each use.** Do not leave accessories plugged in for extended periods of time.

SHR31029_(pn 2120-31029-2) 10 22 2021