



www.stealthhitches.com 833-694-4824

HITCH INSTALLATION INSTRUCTIONS

MAKE:	YEARS:	MODEL/TRIM:
BMW	2019-2021	X4 - xDrive 30i with M-sport package
	2022-2024	X4 - xDrive 30i (G02 Chassis)
	2019-2021	X4 - M40i (G02 Chassis)
	2019-2022	X4 - M (F98 Chassis)
	2019-2023	X4 - M Competition (F98 Chassis)

RACK RECEIVER KIT#: **SHR31023**

COMPATIBLE WITH TOW KIT: **SHT25008**



2" RACK RECEIVER MAXIMUM PAYLOAD: 600 LBS
MAXIMUM TOW RATING: 6000 LBS
MAXIMUM TONGUE WEIGHT: 600 LBS

UNDER VEHICLE TRIMMING:

HEAT SHIELD: **NO**
 FASCIA: **YES (G02 CHASSIS ONLY)**
 GRAVEL GUARD TRIMMING: **YES (SOME MODELS)**



READ ALL INSTRUCTION WARNINGS AND LABELS



NO WELDING, METAL DRILLING OR VISIBLE TRIMMING REQUIRED

PARTS SUPPLIED WITH RACK RECEIVER KIT:



LATCH BLOCK & KEYS



(2) BOLTS
5/8"-11 x 5"



(2) 5/8"
NYLOCK NUTS

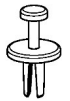

(6) PLASTIC
RIVETS



2" RACK
RECEIVER



8" CABLE TIE

ADDITIONAL PARTS FOR TOW KIT:

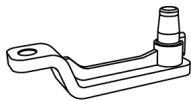

BALL MOUNT
5" RISE, SHORT



CHAIN HOOKS



2" BALL

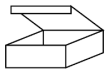

PASSIVE WIRING
KIT BOX

TOOLS REQUIRED:



15/16" OPEN
END WRENCH



18mm DEEP WELL,
8mm, 10mm, 13mm,
& 15/16" SOCKETS



RATCHET

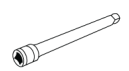

SOCKET
EXTENSION



10 mm
HOLLOW NUT
DRIVER

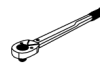

TORQUE
WRENCH



T20 TORX



PLASTIC
PRY TOOLS



SAFETY GLASSES



90 DEGREE
PICK



FLASHLIGHT



TIN SNIPS
(SOME VEHICLES)



PAINTER'S TAPE



DREMEL TOOL
(G02 ONLY)



FILE
(G02 ONLY)

ADDITIONAL TOOLS FOR TOW KITS:



PLIERS



DRILL, 3/8 BIT, &
5/16" BIT (NEEDED
FOR SOME MODELS)



SILICONE



MULTIMETER



STRIPPER/
CRIMPING
TOOL



PHILLIPS HEAD
SCREWDRIVER



FLATHEAD
SCREWDRIVER



T40 or T50
TORX
(F98 ONLY)

RACK RECEIVER INSTALLATION: USE STEPS 1-23, & 44-52
TOW KIT INSTALLATION: USE STEPS 1-52

<THESE INSTRUCTIONS MUST BE GIVEN TO THE END USER>

NOTICE: Installation of Stealth products may or may not require the addition of a wiring harness to the vehicle.

- The Rack Receiver only product does not require adding a wiring harness.
- The Rack Receiver plus Tow Kit requires the addition of a "Passive" wiring harness to the vehicle. The passive harness "reads" the output of the vehicle's lights and translates the signals to the trailer without being connected to the vehicle computer.

INSTALLATION NOTE: In most instances, these instructions will only outline disassembly of vehicle components. Re-installation of components will require the installer to retain vehicle hardware and work through disassembly instructions in reverse order. When installation is complete, double check that all vehicle components have been replaced and are secured.

IMPORTANT SAFETY NOTICE FOR STEALTH HITCH INSTALLERS AND CUSTOMERS.

Read all installation and operating instructions along with all labels before installing or using this product. Do not perform any installation or towing procedures without fully understanding the correct tools and actions for all steps. Call for support if needed.

⚠ WARNING Failure to comply with the safety information in these instructions could result in serious injury or death.

- ⚠ Do not modify this product in any manner. Doing so could alter its integrity and lead to a loss of attachment between the trailer and the tow vehicle.
- ⚠ Adding Stealth hitch components to the chassis of any vehicle can be hazardous. There is potential for unexpected combustion of fuel, electric shock, burns, shifting or falling of unstable vehicle, damage to vehicle, injury from tool usage and many other hazards. This installation must be completed by someone who is aware of the hazards involved. This person must be knowledgeable of proper safety procedures for a vehicle modification of this nature, and for usage of the equipment required to perform the installation.
- ⚠ Without proper knowledge, towing can be a dangerous activity. Understand all the risks involved with towing before proceeding. For information on towing safety, see "**The Trailer Handbook: A Guide to Understanding Trailer and Towing Safety**" from the National Association of Trailer Manufacturers, www.NATM.com and your trailer and tow vehicle manufacturer's owner's manual.
- ⚠ Do not exceed tow or tongue rating of coupler, tow or tongue rating of hitch, or tow or weight ratings of tow vehicle or trailer. See vehicle and trailer manufacturer information for ratings. Exceeding these ratings may cause damage to towing components or loss of attachment between the trailer and vehicle.
- ⚠ While installation is being performed, check for signs of damage or excessive corrosion. Do not install hitch components over vehicle parts that are broken or have compromised structural integrity.
- ⚠ This product was designed to fit vehicles in their original, "as manufactured" condition. Compatibility with vehicles having replacement parts, or other modifications is not guaranteed. Inspect vehicle for modifications before installation of this product.
- ⚠ Some accessories, like the rack receiver, are not rated for towing. Do not use any accessories without proper knowledge of their use.
- ⚠ A visual inspection of the hitch should be performed before each use. Regularly check that all connections are secure, including those that secure the hitch to the vehicle. Check for cracks or damage to the hitch. Do not use the hitch if cracks or damage outside of normal wear is found. Using a hitch that has unsecure connections and/or cracks or damage could result in damage to the tow vehicle, trailer, towing components and loss of attachment between the tow vehicle and trailer.
- ⚠ Stealth hitches are not compatible with any weight distribution or sway control products. Adding additional products to the trailer or chassis which modifies the function of the Stealth hitch may cause hitch failure.

NOTICE: Installation of hitch requires removal of vehicle parts and interaction with vehicular electronics. Before installation, check the condition of body panels and note any locations where panels are not flush. Check the electronic functions of the vehicle, such as: headlights, taillights, turn signals, cameras, backup sensors, Parking Distance Controller (PDC), foot activated cargo access, etc. It is the responsibility of the installer to restore the fit and function of the vehicle.

GAIN ACCESS TO MOUNTING AREA



1. Open the vehicle cargo area. Remove both taillight covers. Use plastic pry tool to remove plastic rivet, slide plastic cover upward and remove. On some vehicles a screw is present under the cover. Use an 8mm socket to remove (1) screw.



2. In the cargo area remove passenger and driver side compartment access panels.

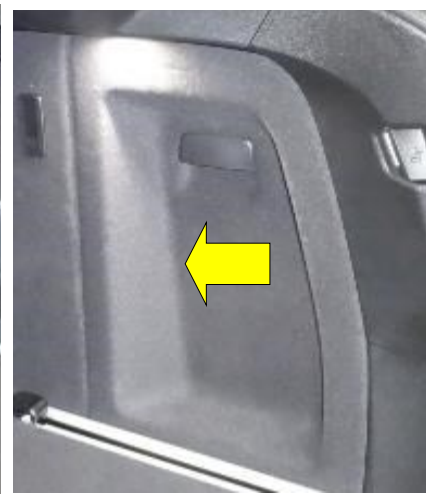

3. The rear trim panel needs to be removed to gain access to the taillights. Remove (2) Torx screws in side compartment. Dislodge the upper part of the trim panel by applying pressure to the inside of the vehicle. Lift upward to remove panel.



GAIN ACCESS TO MOUNTING AREA CONTINUED



10mm
SOCKET

- OR -



10 mm
HOLLOW NUT
DRIVER

4. Locate and remove (2) rubber grommets on the rear wall of the vehicle. Remove (2) nuts from inside the holes that were covered by grommets. These nuts secure the rear of the taillights.

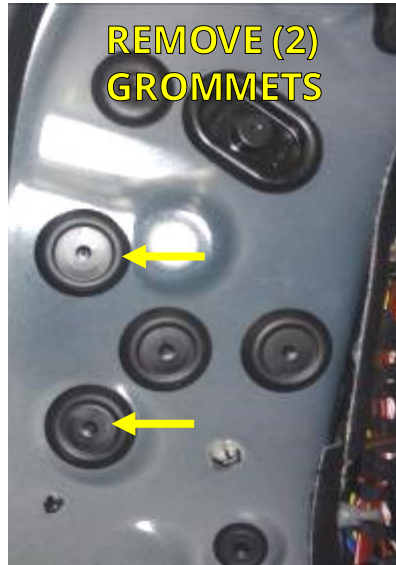

10mm
SOCKET

5. Locate and remove (1) nut on the side wall of the vehicle holding the taillights.
6. Unplug taillight connector (yellow arrow). Remove taillight. Repeat Steps 3-6 on other side of vehicle.



8mm
SOCKET

7. Use a socket to remove (2) screws from the top of the fascia.



GAIN ACCESS TO MOUNTING AREA CONTINUED



PLASTIC PRY TOOLS



90 DEGREE PICK

8. Locate the rivets inside the rear wheel wells. Use a 90 degree pick or a pry tool to remove (3) most rearward plastic rivets. The rivets secure the wheel well trim to the vehicle.

NOTE: Make sure not to damage the wheel well trim piece.

NOTE: Replacement plastic rivets are supplied.

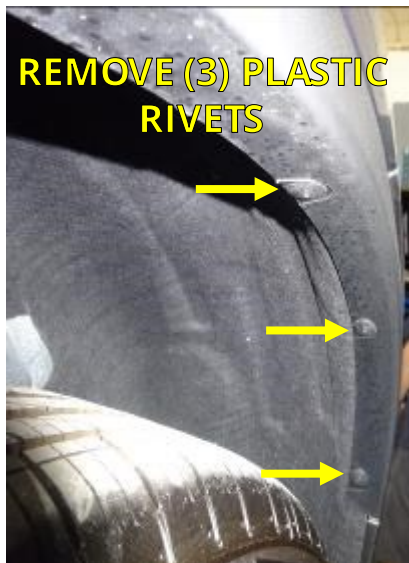

PLASTIC PRY TOOLS

9. To allow partial removal of the rear wheel well trim, (3) clips will need to be disconnected. Apply outward pressure on wheel well trim. Start with the bottom clip and work up. Push down on clip to disconnect. Use a plastic pry tool on hard to reach clips.



8mm SOCKET



PAINTER'S TAPE

10. Behind the rear wheel well trim are (2) screws holding the fascia. Pull the trim away from vehicle to expose screws. Use a socket to remove screws. Repeat Steps 9-10 on other side of vehicle.

NOTE: To protect the trim from being scratched during the removal or replacement, cover it with painter's tape or something similar.



GAIN ACCESS TO MOUNTING AREA CONTINUED



8mm
SOCKET

- OR -



10mm
SOCKET

11. X4 G02 2020 only

Underneath the vehicle, use a socket to remove (8) screws from the bottom of the fascia.



8mm
SOCKET

- OR -



10mm
SOCKET

12. All other models

Underneath the vehicle, use a socket to remove (10) screws from the gravel guard.

NOTE: Some vehicles do not have a gravel guard and that area will be exposed.

13. Remove (4) screws from the bottom edge of the fascia.

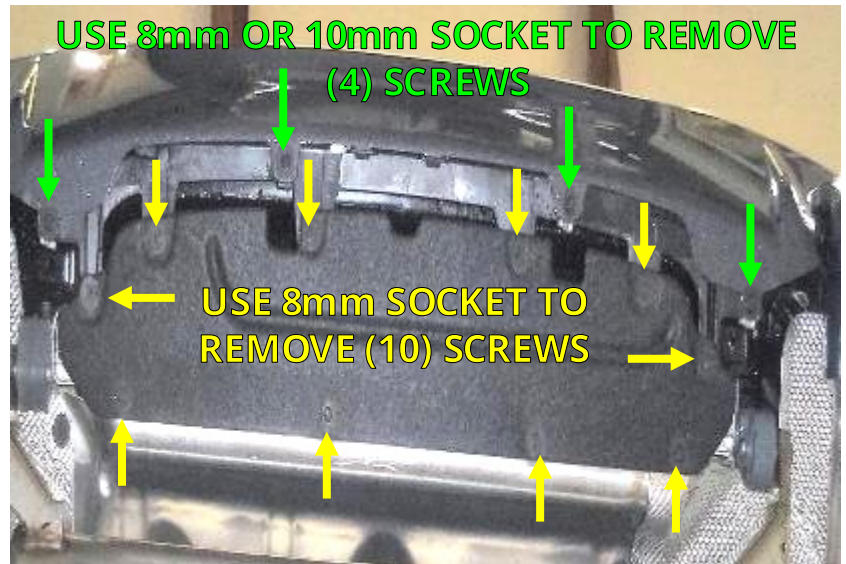

8mm
SOCKET

- OR -



10mm
SOCKET

14. Use a socket to remove (4) screws from the outer edges of the fascia, two on each side.

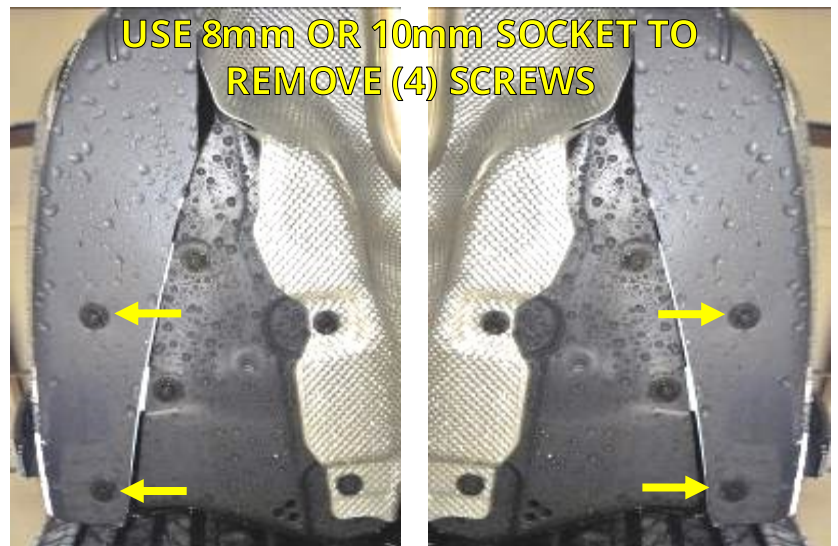

GAIN ACCESS TO MOUNTING AREA CONTINUED



NOTICE: If the rear reflectors are vertical instead of horizontal skip Step 15. Do not remove the reflectors if they are vertical.

15. Remove the rear fascia reflectors. Slide hand underneath vehicle, behind the fascia, to find the center clip of the reflector. Push upward and to the rear of the vehicle on the center clip. At the same time, release the metal clip using a plastic pry tool to pry from the inner corner, outward.

NOTE: On some vehicles the center clip of the reflector can be difficult to reach from underneath the vehicle, because of limited space.

16. A screw, which is holding the fascia, will be exposed when the reflector is removed. Use a socket to remove the screw. Repeat Steps 15-16 on other side of vehicle.

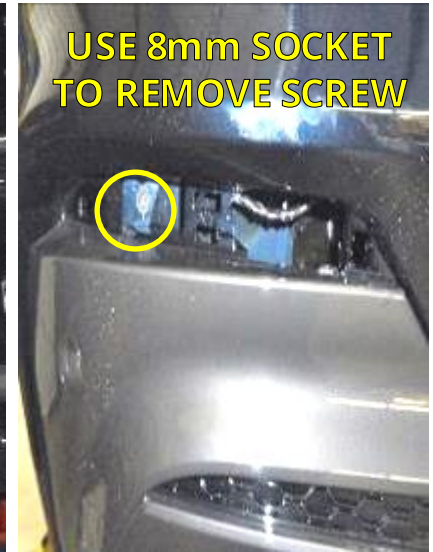

17. The fascia is clipped to the vehicle body directly behind the wheel wells. Pull outward on the fascia to expose the first clip in the seam. With a plastic pry tool, push down on the exposed clip to disconnect. Continue to pull outward on the fascia and disconnect clips as they are exposed. Continue until all clips are released. Repeat on other side of vehicle.



18. This step requires a partner. Pull the fascia rearward enough to access the (2) PDC sensor plugs, one on each side of the vehicle. Unplug the PDC sensor plugs. Remove the fascia completely.

NOTICE: Carefully remove the fascia and place on a blanket or pad.



GAIN ACCESS TO MOUNTING AREA CONTINUED



13mm
SOCKET

- OR -



13mm
DEEP WELL
SOCKET

19. Locate the two exhaust brackets under the rear of the vehicle, above the muffler. Use a socket to remove (1) exhaust bracket nut on each side of the vehicle.

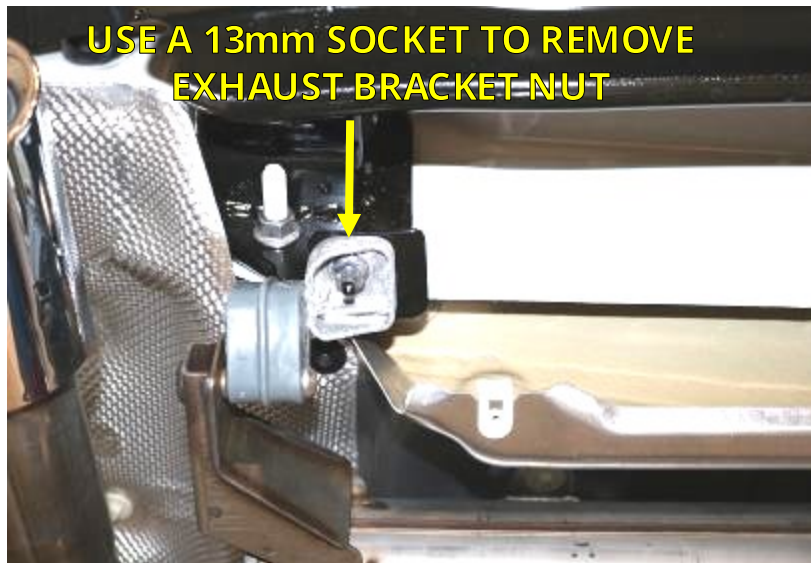

USE A 13mm SOCKET TO REMOVE
EXHAUST BRACKET NUT



90 DEGREE
PICK

20. Remove (6) plastic rivets from plastic insert secured to factory reinforcement beam. Do not unplug wires attached to plastic insert, let plastic insert hang free.



USE A 90 DEGREE PICK TO REMOVE
(6) RIVETS

FACTORY REINFORCEMENT BEAM



18mm
DEEP WELL
SOCKET

21. Remove (4) nuts from factory reinforcement beam and remove factory reinforcement beam. **Save** (4) nuts for reinstallation.

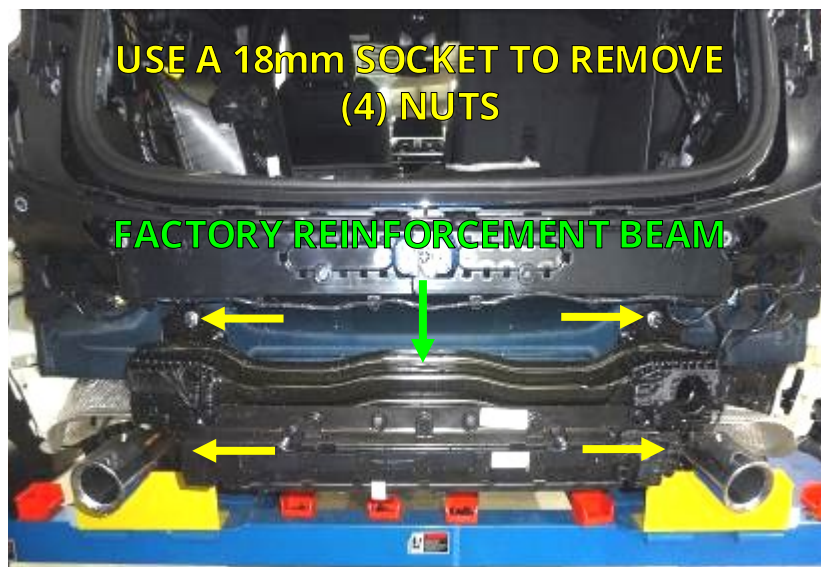

USE A 18mm SOCKET TO REMOVE
(4) NUTS

FACTORY REINFORCEMENT BEAM

INSTALL STEALTH HITCH FRAME



22. Install the Stealth hitch frame and factory reinforcement beam onto the vehicle using (4) factory nuts, as shown. Center the hitch frame and beam before tightening. Use a torque wrench to tighten the bolts to 85 ft.-lbs.

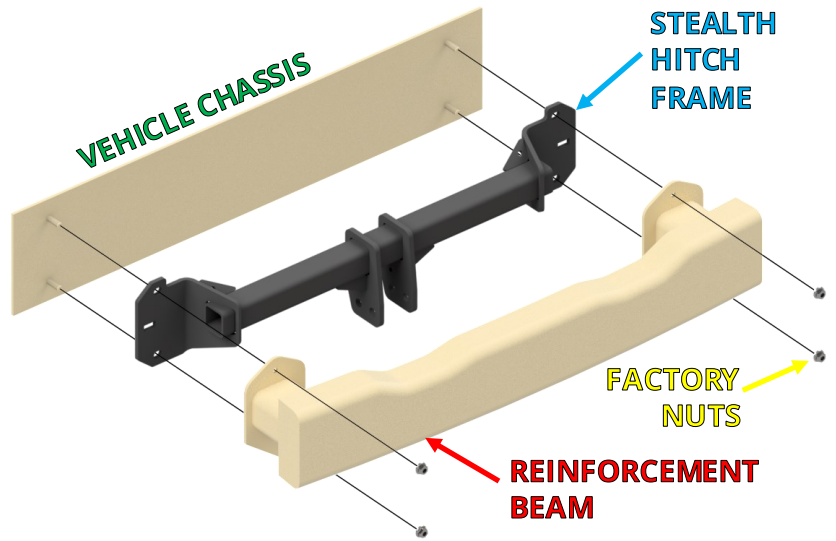

MOUNT LATCH BLOCK



23. Installation of the latch block varies depending on which kit you are installing.

- **Rack Receiver Kit:** Install the latch block with (2) 5/8"-11 x 5" bolts and (2) 5/8" nylock nuts. Tighten each bolt to 150 ft.-lbs.
- **Tow Kit:** Retrieve Z-bracket from wiring harness kit box. Install the latch block, (2) chain hooks, and Z-bracket with (2) 5/8"-11 x 5" bolts and (2) 5/8" nylock nuts. Tighten each bolt to 150 ft.-lbs.

NOTICE: Keys are packaged within the latch block, remove keys and store in safe location.

RACK RECEIVER KIT INSTALL



TOW KIT INSTALL

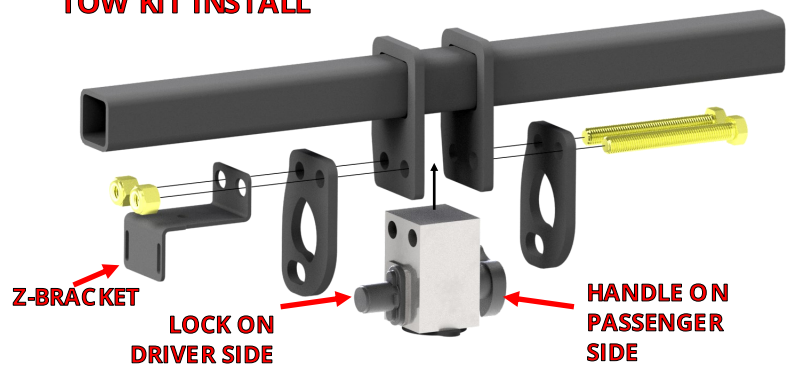

IF INSTALLING A RACK RECEIVER KIT, SKIP TO STEP 44.
IF INSTALLING A TOW KIT, CONTINUE TO STEP 24.

INSTALL PASSIVE WIRING KIT

#	DESCRIPTION	QTY
1	7-WAY WIRING HARNESS • FUSE HOLDER & FUSE • CONTROL MODULE & WIRES	1
2	ADHESIVE FOAM STRIP	2
3	FORK TERMINAL	1
4	CLAMP-ON CONNECTORS	5
5	5/8" LONG PHILLIPS SCREWS	4
6	M10 SERRATED FLANGE NUT	4
7	CABLE TIE - 8"	4
8	CABLE TIE - 14"	3
9	Z-BRACKET	1
10	MOUNTING BRACKET	1
11	7-POLE HOUSING	1
12	7-POLE TO 4-POLE ADAPTER	1



24. Locate the wiring kit box. Review the contents of the box against the list above to check for missing components. The passive wiring kit uses a control module to manage the functions of the trailer lighting. The module has an "input" side that receives power from the vehicle's battery and signals from the vehicle's taillights. The "output" side of the module delivers this information to the 7-way plug. The control module is connected to the vehicle's battery and taillight wiring as outlined in the next steps.

NOTICE: Do not allow electrical system to become disconnected from power or ground. Doing so may interrupt electrical systems.

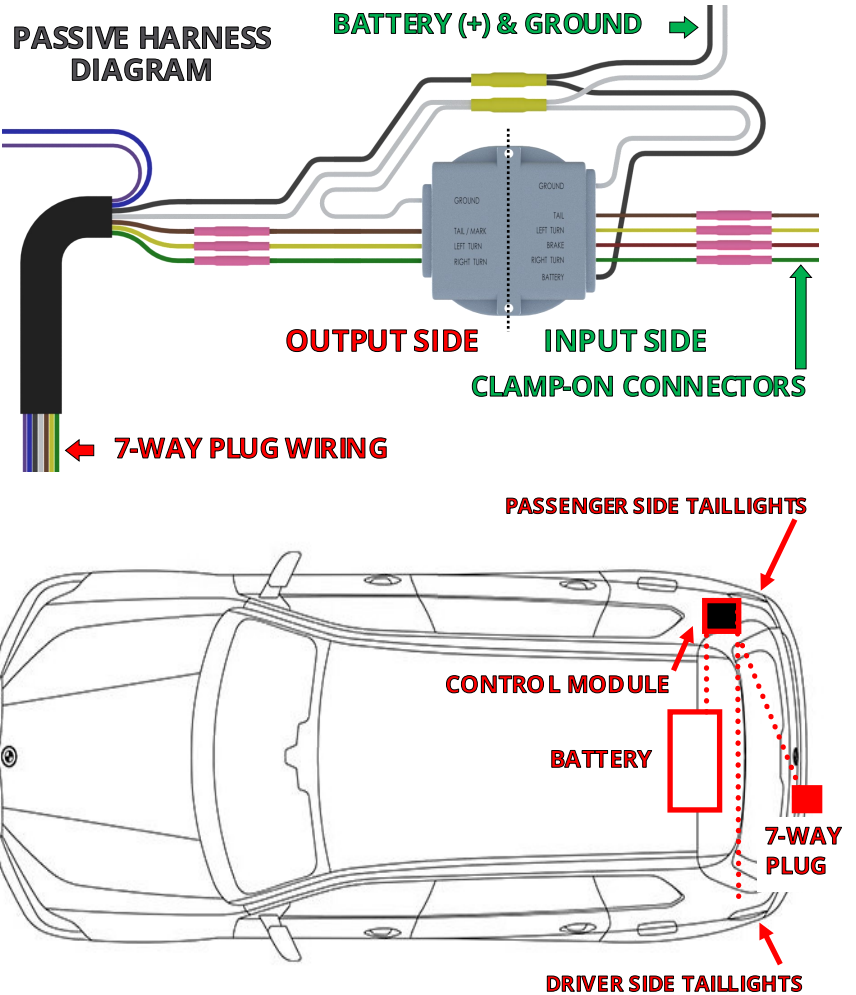

INSTALL WIRING KIT CONTINUED



T40 TORX

- OR -



T50 TORX

25. **F98 only** Open (2) plastic covers. Use torx to remove (2) screws. Remove cargo area floor panel from vehicle.



26. **F98 only** Unlatch strap, and remove spare tire from vehicle. Refer to owner's manual. Remove foam inserts from vehicle.

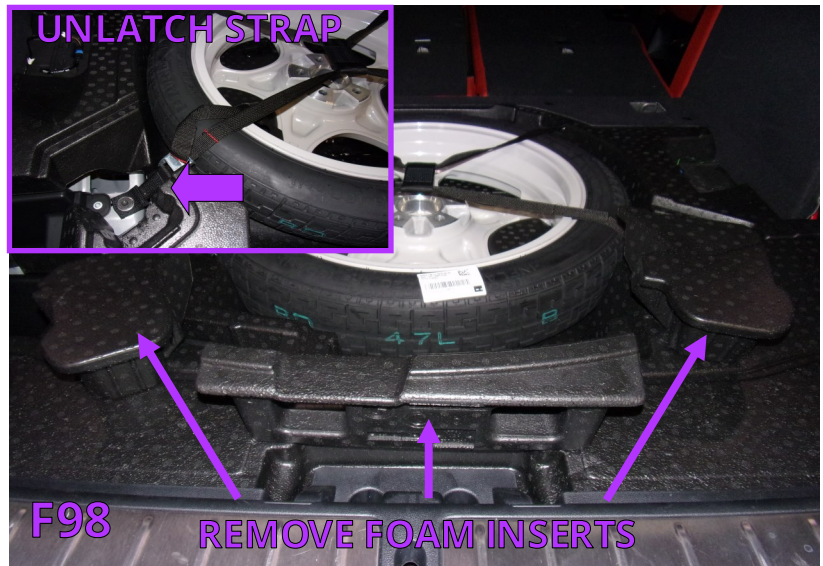

T20 TORX



PLASTIC PRY TOOLS

27. **F98 only** Use T20 Torx to remove (2) screws at rear of cargo area. Lift the threshold and remove.

28. **F98 only** Remove the long rear foam piece covering the battery.

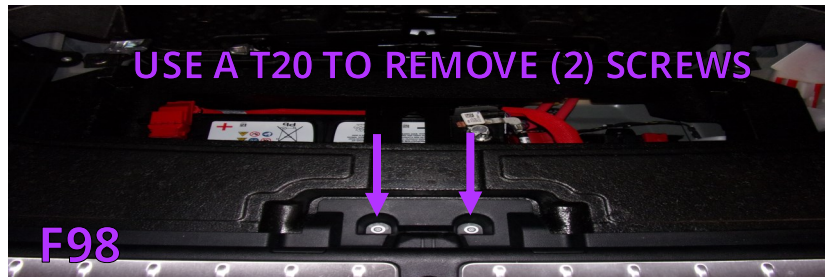

INSTALL WIRING KIT CONTINUED



FLATHEAD
SCREWDRIVER

29. **G02 only** Lift up the cargo area floor panel and hook it up. Remove (2) plastic rivets from under floor panel to gain access to battery compartment.



10mm
SOCKET

30. Locate and remove (5) nuts holding the plastic fascia support bracket. Remove fascia support bracket.



DRILL &
3/8" BIT

31. Locate wiring grommet on passenger side of vehicle. Drill a 3/8" hole in the grommet using indicated dimple as a guide.

NOTICE: Check for obstructions on other side of grommet before drilling. Use caution when drilling.

32. Feed output wires through grommet from inside vehicle to outside of vehicle.



INSTALL WIRING KIT CONTINUED



PLIERS



MULTIMETER

33. The wires on the input side of the wiring module need to be attached to the vehicle wiring. Using an existing vehicle wire harness as a guide route the yellow wire to the driver side of the vehicle. Locate the indicated part of the vehicle wiring harness. Use a clamp-on connector to connect the yellow wire to the left turn signal wire behind taillight. (See reference table below.)

Note: Vehicles may have different wire colors than those shown. Verify circuits (wire colors) with multimeter.

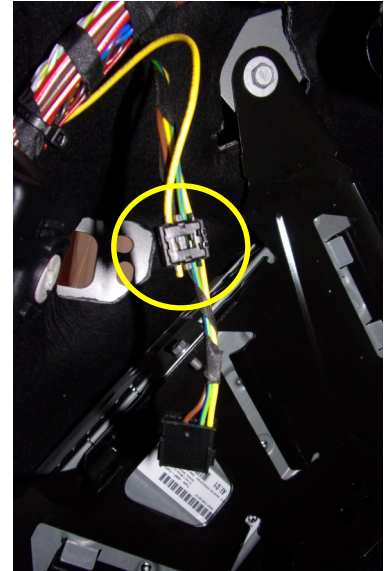

PLIERS







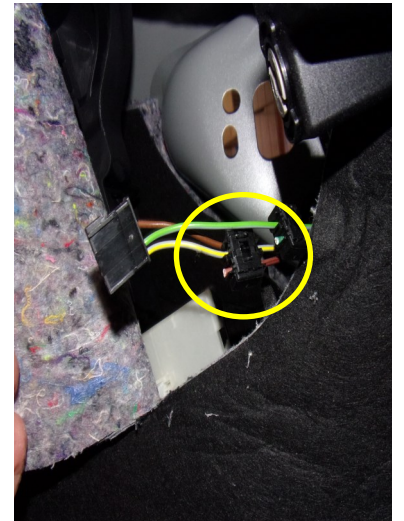





MULTIMETER

34. Inside the passenger side compartment locate the indicated part of the vehicle wiring harness. Use clamp-on connectors to connect the brown and green wires to wires behind taillight. (See reference table below.)



CLAMP-ON CONNECTOR COLOR REFERENCE TABLE

SIGNAL INPUT WIRES			POWER & GROUND WIRES		
FUNCTION	HARNESS	VEHICLE			
<u>LEFT TURN</u>	 YELLOW	 GREEN/BLUE	<u>12V+ (POWER)</u>	 BLACK	BATTERY (+)
<u>RIGHT TURN</u>	 GREEN	 GREEN/GRAY	<u>GROUND</u>	 WHITE	BATTERY (-) <i>or</i> GROUND STUD
<u>MARKER</u>	 BROWN	 GRAY/YELLOW			
<u>BRAKE</u>	 RED	Do not connect the red brake wire. This vehicle does not utilize a separate brake circuit. The brake signal is sent down the left and right turn circuits simultaneously.			
<u>REVERSE</u>	 PURPLE	For use with trailer reverse lights or to disable the trailer brakes when backing with surge brakes. To connect, isolate vehicle's reverse light circuit and connect the purple wire from the trailer wiring harness to vehicle reverse light circuit. Trailers rarely have reverse lights or surge brakes.			
<u>ELECTRIC BRAKE</u>	 BLUE	Only used when a hard wired brake controller is mounted inside the vehicle and your trailer has electric brakes. See brake controller instructions for this wire.			

NOTE: If two colors are listed, the first color is the dominant color.

INSTALL WIRING KIT CONTINUED



10mm
SOCKET



STRIPPER/
CRIMPING
TOOL

35. **F98 only** Locate the ground stud in the rear passenger side cargo area. Trim white ground wire so it will reach stud without excess wire. Crimp supplied fork terminal to the ground wire with a crimping tool. Loosen the ground stud and secure the fork to the ground stud.

NOTICE: Loosen ground stud just enough to install fork terminal, so vehicle wiring does not lose ground.

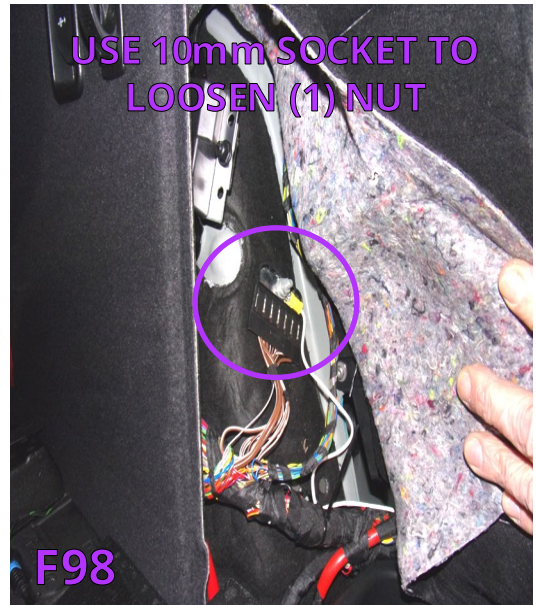

10mm
SOCKET

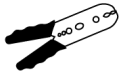

STRIPPER/
CRIMPING
TOOL

36. **G02 only** Trim white ground wire so it will reach negative battery terminal (-) without excess wire. Crimp supplied fork terminal to the ground wire with a crimping tool. Loosen the ground stud and secure the fork to the ground stud.

NOTICE: Loosen ground stud just enough to install fork terminal, so vehicle wiring does not lose ground.



10mm
SOCKET

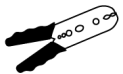

STRIPPER/
CRIMPING
TOOL

37. Trim black power wire so it will reach positive battery terminal (+) without excess wire. Locate the fuse holder supplied in the wiring kit box. Remove the fuse from the fuse holder. Route the power wire to the battery positive terminal. Crimp the fuse holder lead to the black power wire and connect to the positive battery terminal (+).

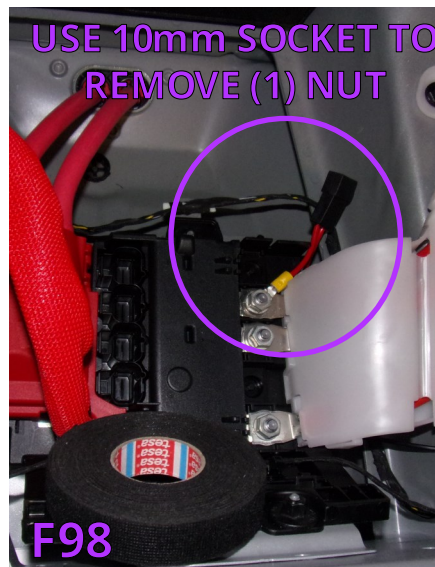

WIRE 7-WAY PLUG



PHILLIPS HEAD
SCREWDRIVER

38. Locate the 7-way housing. Use a screwdriver to loosen (2) screws. Remove 7-way round terminal block. Place the mounting bracket onto the 7-way housing as shown. Use a screwdriver to loosen the set screw at the bottom of the 7-way housing. Route output side wires of the wiring harness through the 7-way housing.

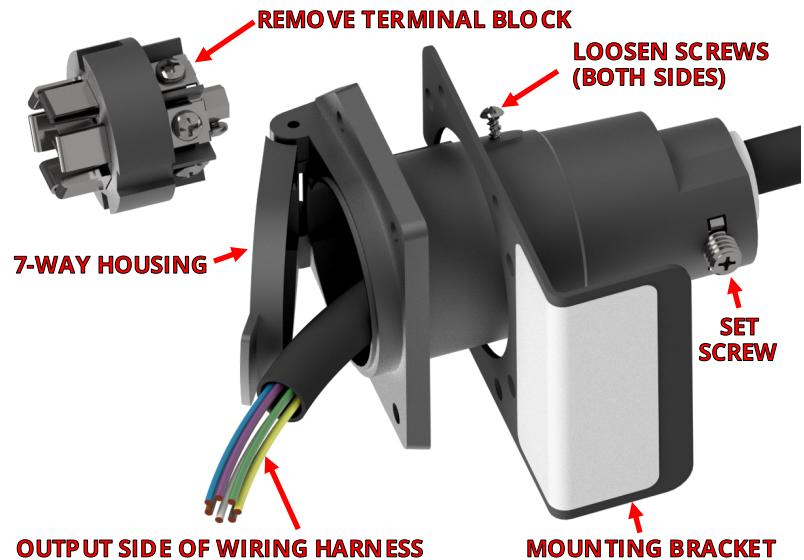

Please follow instructions below very carefully.
Incorrect wiring of the 7-way receptacle causes the vast majority of wiring problems.



PHILLIPS HEAD
SCREWDRIVER

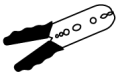

STRIPPER/
CRIMPING
TOOL

39. Locate the slot keyway. Starting from the keyway going **clockwise**, attach the wires as follows:

- Blue
- Green
- Black
- Brown
- Yellow
- White
- Purple (middle)

NOTICE: Markings on the receptacle may not match the correct wire configuration. Please disregard and follow the instruction above.

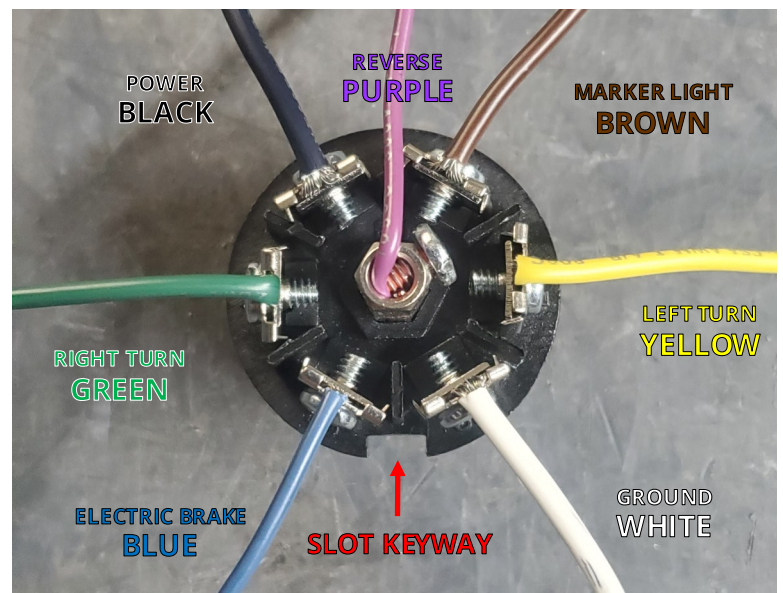

TEST 7-WAY HARNESS WIRING



PHILLIPS HEAD
SCREWDRIVER



MULTIMETER

40. Put the 7-way receptacle back together. While everything is still accessible, you should test the wiring to make sure everything is connected properly and in working order. **Replace the 20 Amp fuse into the fuse holder located near the battery.**

NOTE: *Taillights will need to be temporarily plugged in during testing.*

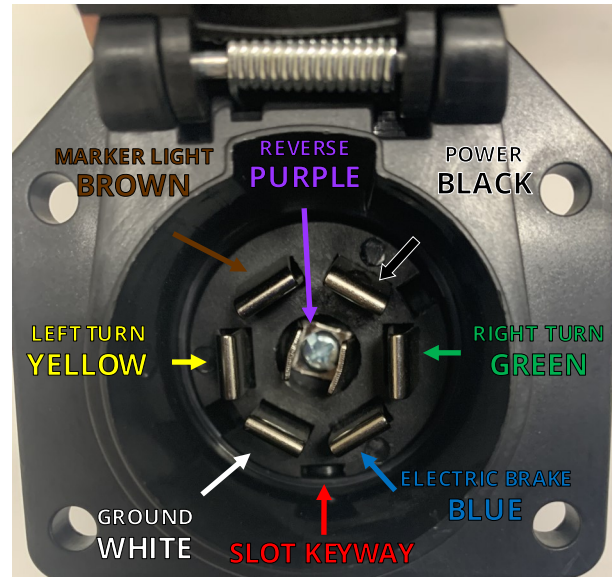

- Start by connecting the multimeter negative probe to the ground blade on the 7-way receptacle.
- Next, connect the multimeter positive probe to the power blade on the 7-way receptacle and check for 12 volts.
- Once that is confirmed, move the positive probe to the left turn blade on the 7-way receptacle and check for 12 volts when the vehicle left turn blinker is active. You should see it pulse.
- Next, move the positive probe to the right turn blade and check for 12 volts when the right turn blinker is active. You should see it pulse.
- Next, move the positive probe to the marker/taillights. With the vehicle lights on you should see 12 volts constant.
- Lastly, with the brake depressed, move the positive probe to the left turn blade where you should see 12 volts constant. Move the probe to the right turn blade where you should also see 12 volts constant.



PHILLIPS HEAD
SCREWDRIVER



SILICONE

41. Attach the mounting bracket and 7-way housing to the Stealth hitch frame as shown. Secure harness to Stealth hitch frame with cable ties.

42. Secure all wires and wiring components. Use the remaining cable ties to secure wiring so that it is not loose and will not interfere with replacement of the fascia. Wiring should not be visible once the vehicle is reassembled.

NOTE: *X4 G02 2020 needs keep 1 cable tie for kick wand bracket.*

43. Use the provided adhesive foam strips to secure the control module to an inside body panel. Use silicone to waterproof grommet.

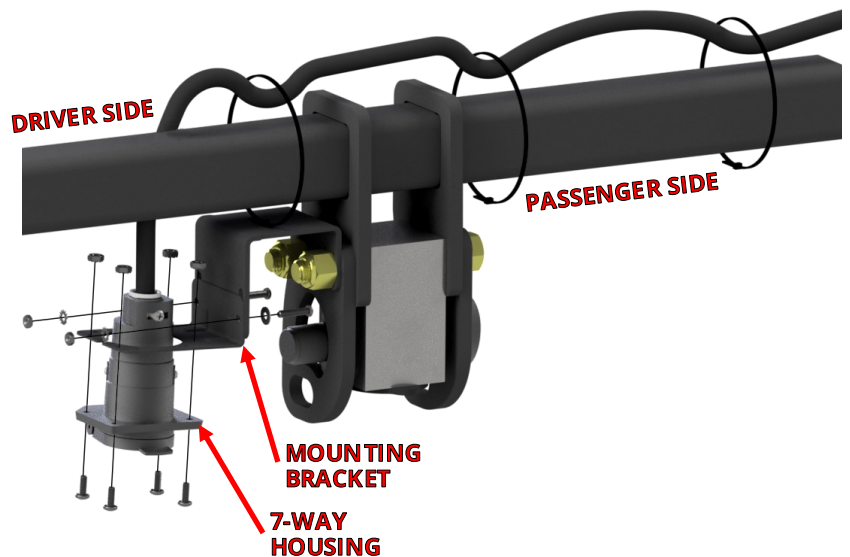

CUT ACCESS IN GRAVEL GUARD (SOME MODELS)



DREMEL TOOL



FILE

44. **X4 G02 2020 only** Remove the kick wand. Cut the kick wand bracket with a Dremel tool. Use a file to smooth out the cut.

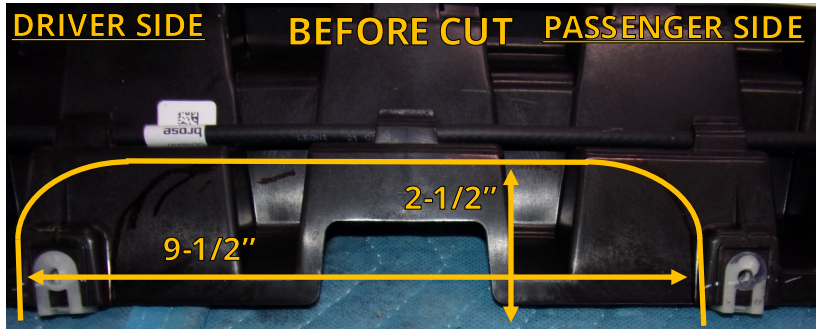

DRILL &
5/16" BIT

45. **X4 G02 2020 only** Drill two holes in the kick wand bracket with a 5/16" drill bit above the previous cut and attach the kick wand with a cable tie.



DREMEL TOOL



FILE

46. **X4 G02 2020 only** Cut the fascia with a Dremel tool. Use a file to smooth out the cut.

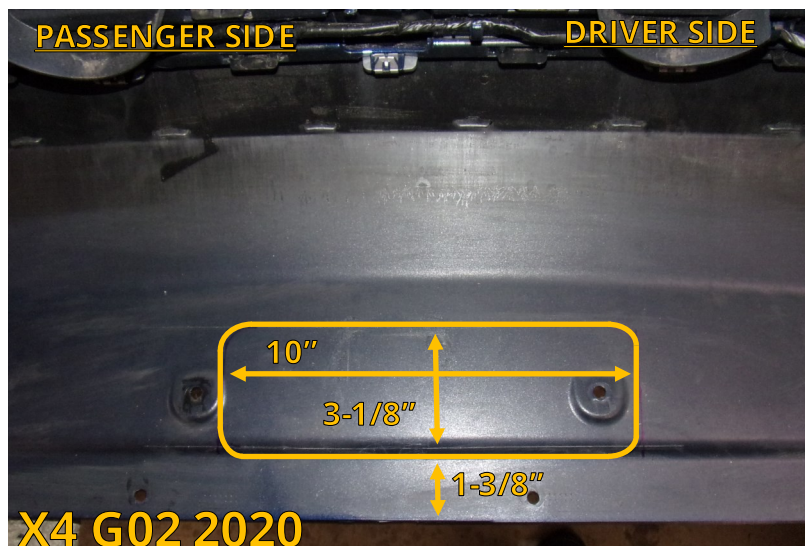

CUT ACCESS IN GRAVEL GUARD (SOME MODELS) CONTINUED

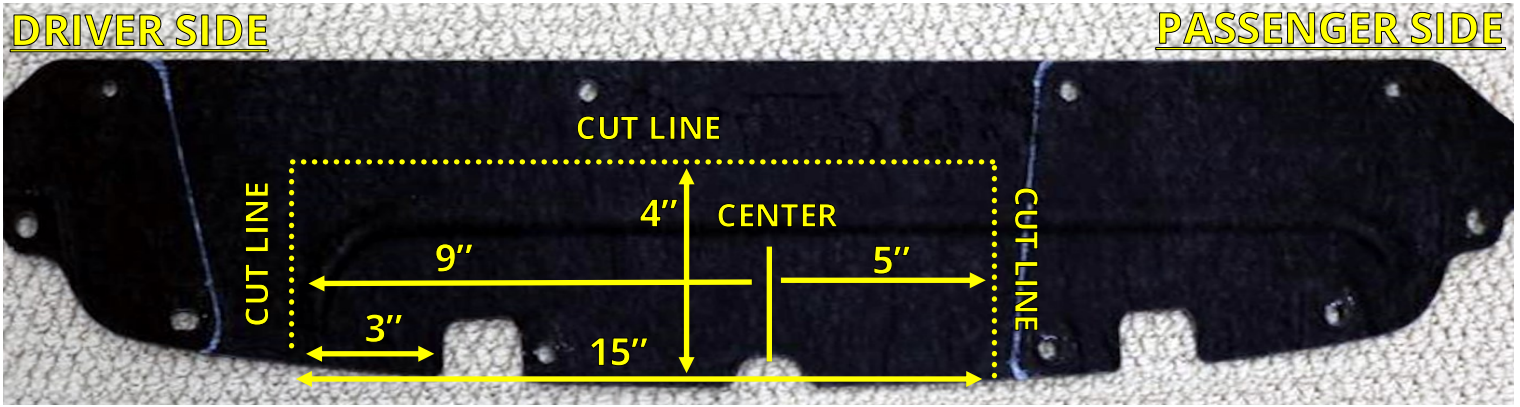

TIN SNIPS

47. Some models require the gravel guard to be cut for access to the latch block. Use tin snips to cut the gravel guard as indicated.



DREMEL TOOL



FILE

48. **G02 only** Cut off the fascia tab with Dremel tool. Use a file to smooth out the cut.



REINSTALL VEHICLE COMPONENTS



PLASTIC
PRY TOOLS

49. **G02 only** Before replacing the rear trim panels, check that the white plastic rivet is not stuck on the vehicle side. If stuck, the rivet needs to be removed and replaced into the rivet-slot on the rear of the trim panels as shown in images.

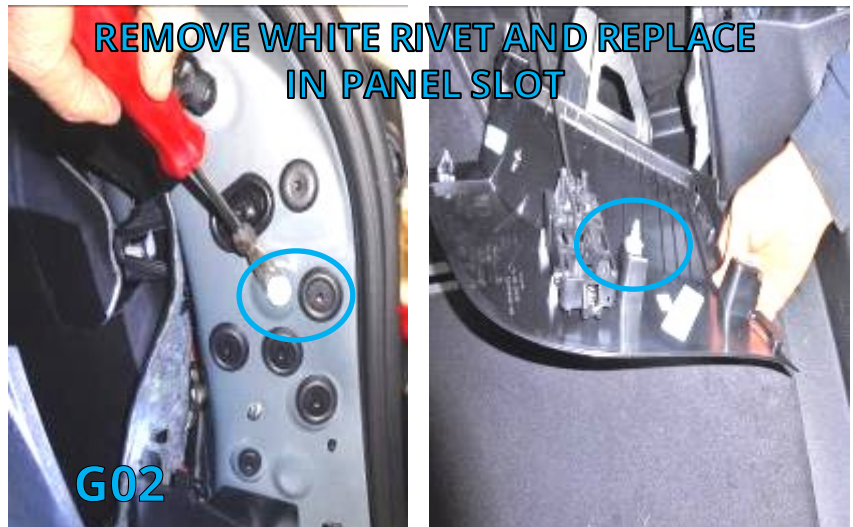

50. Reattach and secure the fascia, taillights, and other vehicle components in reverse order. Refer to Steps 25-30 and 1-20.

NOTICE: Remember to plug in the sensor plugs in Step 18 before reinstalling the fascia.

NOTE: Replace plastic rivets in the wheel well with supplied plastic rivets, see Step 8.



FINAL VEHICLE EXAMINATION

51. Examine the body panels to ensure that they are in a pre-installation condition. Test the electronic functions of the vehicle. Correct any inconsistencies.
52. Ensure that hitch components work properly.
 - **Verify that the lock works correctly.** Push in the safety lock on the latch block then unlock with key. The lock should slide back out with the key when unlocked.
 - **Verify that each accessory can be installed correctly.** Use the following steps to install and remove each accessory that will be used with the hitch. (*Rack Receiver* and *Ball Mount* if purchased.)
 1. Prepare latching mechanism. Turn handle clockwise if needed.
 2. Firmly insert "post" of accessory into latch block until handle releases indicating that the accessory is latched.
 3. Push in the safety locking pin until it fully engages. The locking pin prevents the handle from turning when pushed in, and confirms that the block is securely latched onto the accessory. The safety locking pin will not depress if the accessory is not fully latched.
 4. Use key to release safety locking pin.
 5. While holding on to the accessory, rotate handle clockwise to release and remove the accessory.
 - **Verify that no part of the accessories come into contact with the body of the vehicle.**

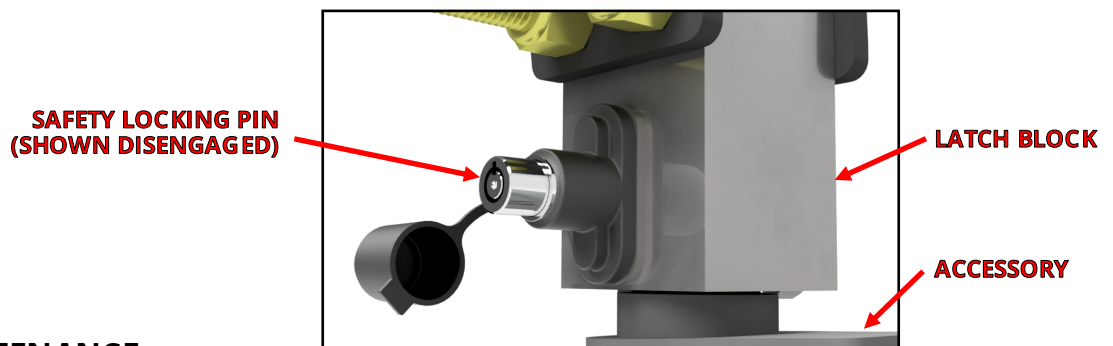

PRODUCT USE AND MAINTENANCE

NOTICE: If the hitch is being installed by a professional, the installer is responsible for training the end user in the use and maintenance of the product.

- **Accessory installation procedure:**
 1. Prepare latching mechanism. Turn handle clockwise if needed.
 2. Firmly insert "post" of accessory into latch block until handle spins counter-clockwise indicating that the accessory is latched.
 3. Always depress the safety locking pin and check that it has fully engaged.
- **Never use any accessory with the safety lock disengaged.** Until the safety locking pin is engaged, the handle is able to turn. A fully engaged safety locking pin is confirmation that the accessory is properly latched into the latch block.
- **Never use the rack receiver for towing.** The rack receiver accessory is only to be used with payload carrying products, such as bike racks or luggage racks.
- **Before each use, give the post of the accessory a light coating of lithium based grease.**
- **Before each use, inspect the hitch to ensure that all bolted connections are secure and that no cracks or damage are present.** Do not tow with the hitch if cracks or damage outside of normal wear is found.
- **Remove the Stealth accessories from the latch block after each use.** Do not leave accessories plugged in for extended periods of time.

SHR31023_(pn 2120-31023-2) 03 15 2024