



HITCH INSTALLATION INSTRUCTIONS

MAKE: BMW **YEARS:** 2020 - 2024 **MODEL/TRIM:** X3 M (F97 CHASSIS)
 2020 - 2024 X3 M COMPETITION (F97 CHASSIS)

www.stealthhitches.com 833-694-4824

RACK RECEIVER KIT#: **SHR31022**

COMPATIBLE WITH TOW KIT: **SHT25015**



2" RACK RECEIVER MAXIMUM PAYLOAD: 600 LBS
MAXIMUM TOW RATING: 6000 LBS
MAXIMUM TONGUE WEIGHT: 600 LBS

UNDER VEHICLE TRIMMING:

HEAT SHIELD: **NO**
 FASCIA: **NO**
 GRAVEL GUARD TRIMMING: **NO**



READ ALL INSTRUCTION WARNINGS AND LABELS



NO WELDING, METAL DRILLING OR VISIBLE TRIMMING REQUIRED

PARTS SUPPLIED WITH RACK RECEIVER KIT:



LATCH BLOCK & KEYS



(2) BOLTS
5/8"-11 x 5"



(2) 5/8"
NYLOCK NUTS

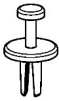

(6) PLASTIC RIVETS

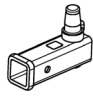

2" RACK RECEIVER

TOOLS REQUIRED:



15/16" OPEN END WRENCH



18mm DEEP WELL,
8mm, 10mm, 13mm & 15/16" SOCKETS

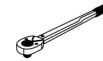

TORQUE WRENCH

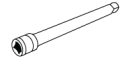

SOCKET EXTENSION



SAFETY GLASSES



FLASHLIGHT



RATCHET



PAINTER'S TAPE



PLASTIC PRY TOOLS



90 DEGREE PICK

ADDITIONAL PARTS FOR TOW KIT:



BALL MOUNT
5" RISE, SHORT



CHAIN HOOKS



2" BALL

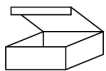

PASSIVE WIRING
KIT BOX

ADDITIONAL TOOLS FOR TOW KIT:



MULTIMETER



STRIPPER/
CRIMPING
TOOL



PHILLIPS HEAD
SCREWDRIVER



FLATHEAD
SCREWDRIVER



PLIERS



SILICONE



DRILL &
3/8" BIT

RACK RECEIVER INSTALLATION: USE STEPS 1-20, & 37-40
TOW KIT INSTALLATION: USE STEPS 1-40

<THESE INSTRUCTIONS MUST BE GIVEN TO THE END USER>

NOTICE: Installation of Stealth products may or may not require the addition of a wiring harness to the vehicle.









- The Rack Receiver only product does not require adding a wiring harness.
- The Rack Receiver plus Tow Kit requires the addition of a "Passive" wiring harness to the vehicle. The passive harness "reads" the output of the vehicle's lights and translates the signals to the trailer without being connected to the vehicle computer.

INSTALLATION NOTE: In most instances, these instructions will only outline disassembly of vehicle components. Re-installation of components will require the installer to retain vehicle hardware and work through disassembly instructions in reverse order. When installation is complete, double check that all vehicle components have been replaced and are secured.

IMPORTANT SAFETY NOTICE FOR STEALTH HITCH INSTALLERS AND CUSTOMERS.

Read all installation and operating instructions along with all labels before installing or using this product. Do not perform any installation or towing procedures without fully understanding the correct tools and actions for all steps. Call for support if needed.

WARNING Failure to comply with the safety information in these instructions could result in serious injury or death.

-  Do not modify this product in any manner. Doing so could alter its integrity and lead to a loss of attachment between the trailer and the tow vehicle.
-  Adding Stealth hitch components to the chassis of any vehicle can be hazardous. There is potential for unexpected combustion of fuel, electric shock, burns, shifting or falling of unstable vehicle, damage to vehicle, injury from tool usage and many other hazards. This installation must be completed by someone who is aware of the hazards involved. This person must be knowledgeable of proper safety procedures for a vehicle modification of this nature, and for usage of the equipment required to perform the installation.
-  Without proper knowledge, towing can be a dangerous activity. Understand all the risks involved with towing before proceeding. For information on towing safety, see "**The Trailer Handbook: A Guide to Understanding Trailer and Towing Safety**" from the National Association of Trailer Manufacturers, www.NATM.com and your trailer and tow vehicle manufacturer's owner's manual.
-  Do not exceed tow or tongue rating of coupler, tow or tongue rating of hitch, or tow or weight ratings of tow vehicle or trailer. See vehicle and trailer manufacturer information for ratings. Exceeding these ratings may cause damage to towing components or loss of attachment between the trailer and vehicle.
-  While installation is being performed, check for signs of damage or excessive corrosion. Do not install hitch components over vehicle parts that are broken or have compromised structural integrity.
-  This product was designed to fit vehicles in their original, "as manufactured" condition. Compatibility with vehicles having replacement parts, or other modifications is not guaranteed. Inspect vehicle for modifications before installation of this product.
-  Some accessories, like the rack receiver, are not rated for towing. Do not use any accessories without proper knowledge of their use.
-  A visual inspection of the hitch should be performed before each use. Regularly check that all connections are secure, including those that secure the hitch to the vehicle. Check for cracks or damage to the hitch. Do not use the hitch if cracks or damage outside of normal wear is found. Using a hitch that has unsecure connections and/or cracks or damage could result in damage to the tow vehicle, trailer, towing components and loss of attachment between the tow vehicle and trailer.
-  Stealth hitches are not compatible with any weight distribution or sway control products. Adding additional products to the trailer or chassis which modifies the function of the Stealth hitch may cause hitch failure.

NOTICE: Installation of hitch requires removal of vehicle parts and interaction with vehicular electronics. Before installation, check the condition of body panels and note any locations where panels are not flush. Check the electronic functions of the vehicle, such as: headlights, taillights, turn signals, cameras, backup sensors, Parking Distance Controller (PDC), foot activated cargo access, etc. It is the responsibility of the installer to restore the fit and function of the vehicle.

GAIN ACCESS TO MOUNTING AREA

1. Open vehicle cargo area and remove driver and passenger side panels for access to rear of the taillights.



PLASTIC
PRY TOOLS



10mm
SOCKET

2. Remove the taillight cover. Use a plastic pry tool to remove plastic rivet. Slide plastic cover upward to remove.



3. Remove (2) nuts from taillight with a socket.

4. Locate and remove third screw holding the taillight inside the vehicle.



5. Remove taillight. Unplug taillight by pushing down on "release clip" then pulling outward.



10mm
SOCKET

GAIN ACCESS TO MOUNTING AREA CONTINUED



8mm
SOCKET

6. Use a socket to remove screw holding fascia that was exposed by removing taillight.



NOTICE: If the rear reflectors are vertical instead of horizontal skip Step 7 & 8. Do not remove the reflectors if they are vertical.



PLASTIC
PRY TOOLS



8mm
SOCKET

7. Remove rear reflector with a plastic pry tool. Start on the side closest to the center of the vehicle and pry outward.
8. A screw will be exposed when the reflector is removed. Use a socket to remove the screw. Repeat Steps 2-8 on other side of vehicle.



PLASTIC
PRY TOOLS

9. Locate and remove (3) plastic rivets inside the rear wheel wells that secure the wheel well trim to the vehicle. Remove the rivets with a plastic pry tool.

NOTE: Make sure not to damage the wheel well trim piece.

NOTE: Replacement plastic rivets are supplied.

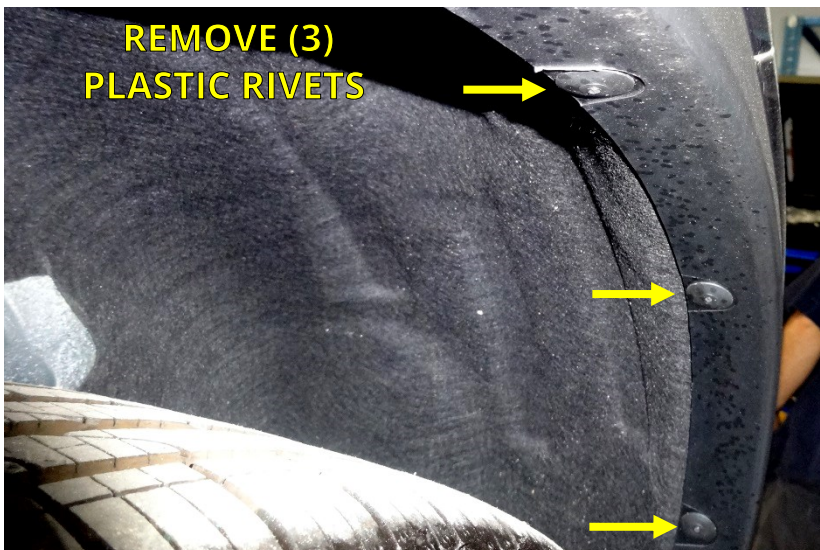

GAIN ACCESS TO MOUNTING AREA CONTINUED



8mm
SOCKET

or



10mm
SOCKET



PLASTIC
PRY TOOLS

10. Remove (1) screw at the bottom of the rear wheel well trim with a socket.

11. To allow partial removal of the rear wheel well trim (6) clips will need to be released. Apply outward pressure on the wheel well trim. Start with the bottom clip and work up. Push down on clip to disconnect. Use plastic pry tools on hard to reach clips.



8mm
SOCKET



PAINTER'S TAPE

12. Behind the rear wheel well trim are (2) screws holding the fascia. Pull the trim away from vehicle to expose screws. Use a socket to remove screws. Repeat Steps 10-12 on other side of vehicle.

NOTE: To protect the trim from being scratched during the removal or replacement, cover it with painter's tape or something similar.



8mm
SOCKET

or



10mm
SOCKET

13. Underneath the vehicle, use a socket to remove (14) screws from the fascia.

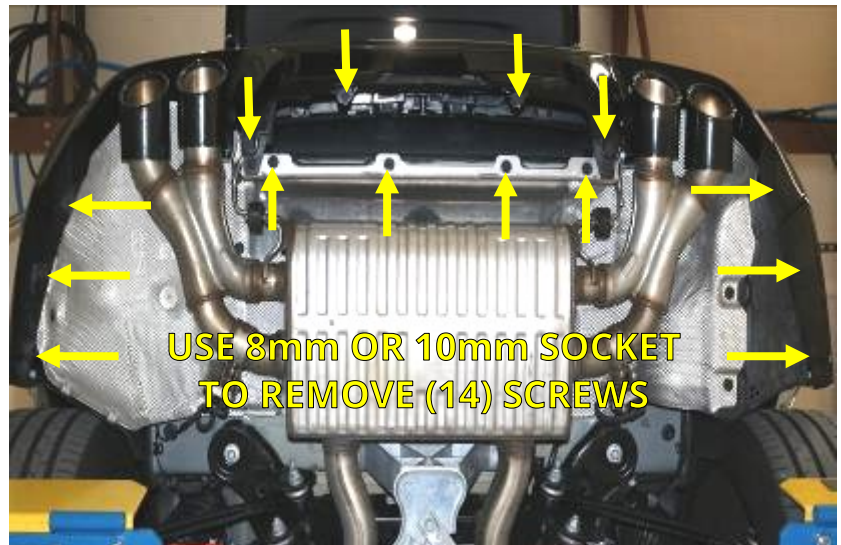

GAIN ACCESS TO MOUNTING AREA CONTINUED



14. The fascia is clipped to the vehicle body directly behind the wheel wells. Pull outward on the fascia to expose the first clip in the seam. With a plastic pry tool, push down on the exposed clip to disconnect. Continue to pull outward on the fascia and disconnect clips as they are exposed until all the clips are released. Repeat on other side of vehicle.



15. This step requires a partner. Pull the fascia rearward enough to access the PDC sensor plug on the passenger side. Press down on the clips to unplug the PDC sensor plug. In some cases a 90 degree pick tool will be needed to disconnect the sensor plug. Remove the fascia completely.

NOTICE: Carefully remove the fascia and place on a blanket or pad.

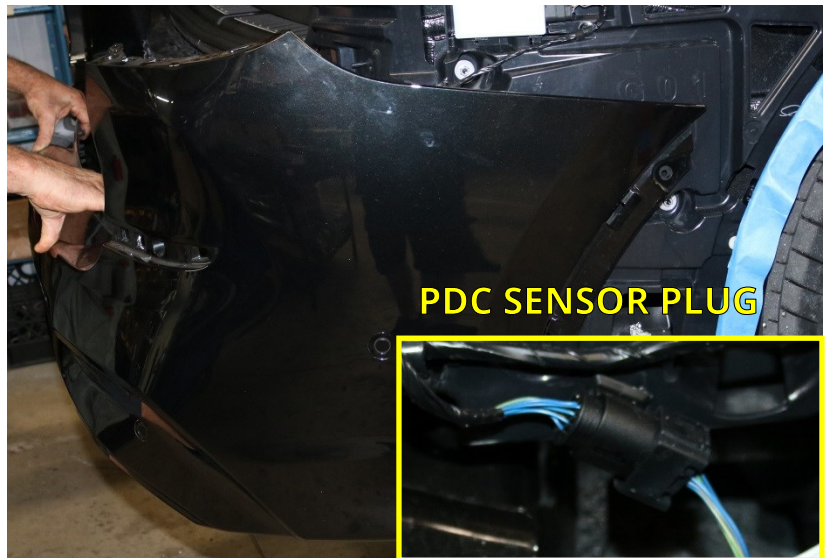

16. Locate the two exhaust brackets under the rear of the vehicle, above the muffler. Use a socket to remove (1) exhaust bracket nut on each side of the vehicle.

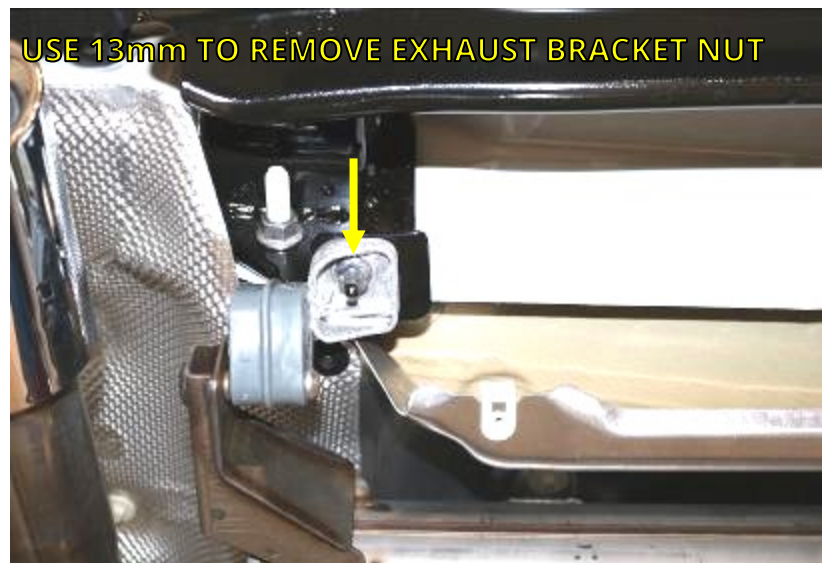

GAIN ACCESS TO MOUNTING AREA CONTINUED



90 DEGREE PICK



18mm DEEP WELL SOCKET

17. Remove (4) plastic rivets from the plastic insert securing it to the factory reinforcement beam. Do not disconnect the wire harness connected to the insert.

18. Remove (4) nuts from factory reinforcement beam and remove factory reinforcement beam. **Save** the factory nuts and reinforcement beam for reinstallation.



INSTALL STEALTH HITCH FRAME

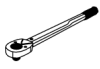

TORQUE WRENCH



18mm DEEP WELL SOCKET

19. Install the Stealth hitch frame and factory reinforcement beam onto the vehicle studs. Use the (4) nuts saved from the factory reinforcement beam. Center the hitch frame and beam before tightening. Use a torque wrench to tighten the nuts to 85 ft.-lbs.

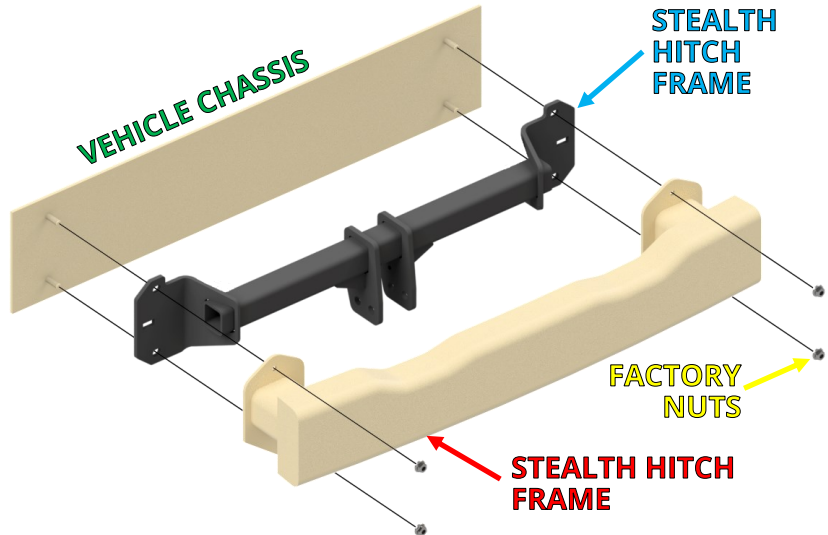

MOUNT LATCH BLOCK



15/16" SOCKET



15/16" OPEN END WRENCH



TORQUE WRENCH

20. Installation of the latch block varies depending on which kit you are installing.

- **Rack Receiver Kit:** Install the latch block with (2) 1/5/8"-11 x 5" bolts and (2) 5/8" nylock nuts. Tighten each bolt to 150 ft.-lbs.
- **Tow Kit:** Retrieve Z-bracket from wiring harness kit box. Install the latch block, (2) chain hooks, and Z-bracket with (2) 5/8"-11 x 5" bolts and (2) 1/2" nylock nuts. Tighten each bolt to 150 ft.-lbs.

NOTICE: Keys are packaged within the latch block, remove keys and store in safe location.

RACK RECEIVER KIT INSTALL



TOW KIT INSTALL

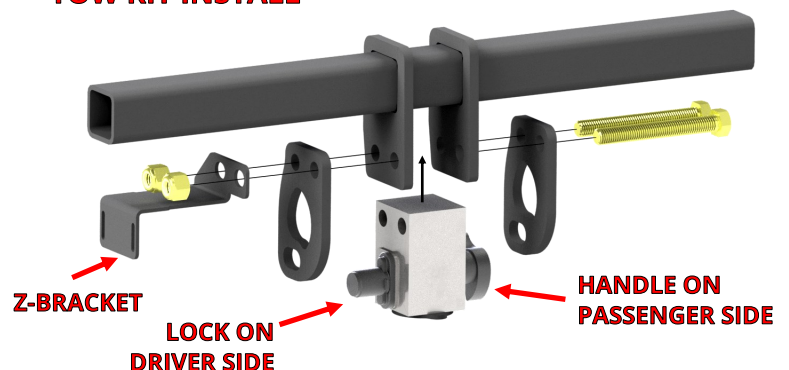

IF INSTALLING A RACK RECEIVER KIT, SKIP TO STEP 37.
IF INSTALLING A TOW KIT, CONTINUE TO STEP 21.

INSTALL PASSIVE WIRING KIT

#	DESCRIPTION	QTY
1	7-WAY WIRING HARNESS • FUSE HOLDER & FUSE • CONTROL MODULE & WIRES	1
2	ADHESIVE FOAM STRIP	2
3	FORK TERMINAL	1
4	5/8" LONG PHILLIPS SCREWS	4
5	#10 LOCK NUT	4
6	CLAMP-ON CONNECTORS	5
7	CABLE TIE - 8"	4
8	CABLE TIE - 14"	3
9	Z-BRACKET	1
10	MOUNTING BRACKET	1
11	7-POLE HOUSING	1
12	7-POLE TO 4-POLE ADAPTER	1



21. Locate the wiring kit box. Review the contents of the box against the list above to check for missing components. The passive wiring kit uses a control module to manage the functions of the trailer lighting. The module has an **"input"** side that receives power from the vehicle's battery and signals from the vehicle's taillights. The **"output"** side of the module delivers this information to the 7-way plug. The control module is connected to the vehicle's battery and taillight wiring as outlined in the next steps.

NOTICE: Do not allow electrical system to become disconnected from power or ground. Doing so may interrupt electrical systems.

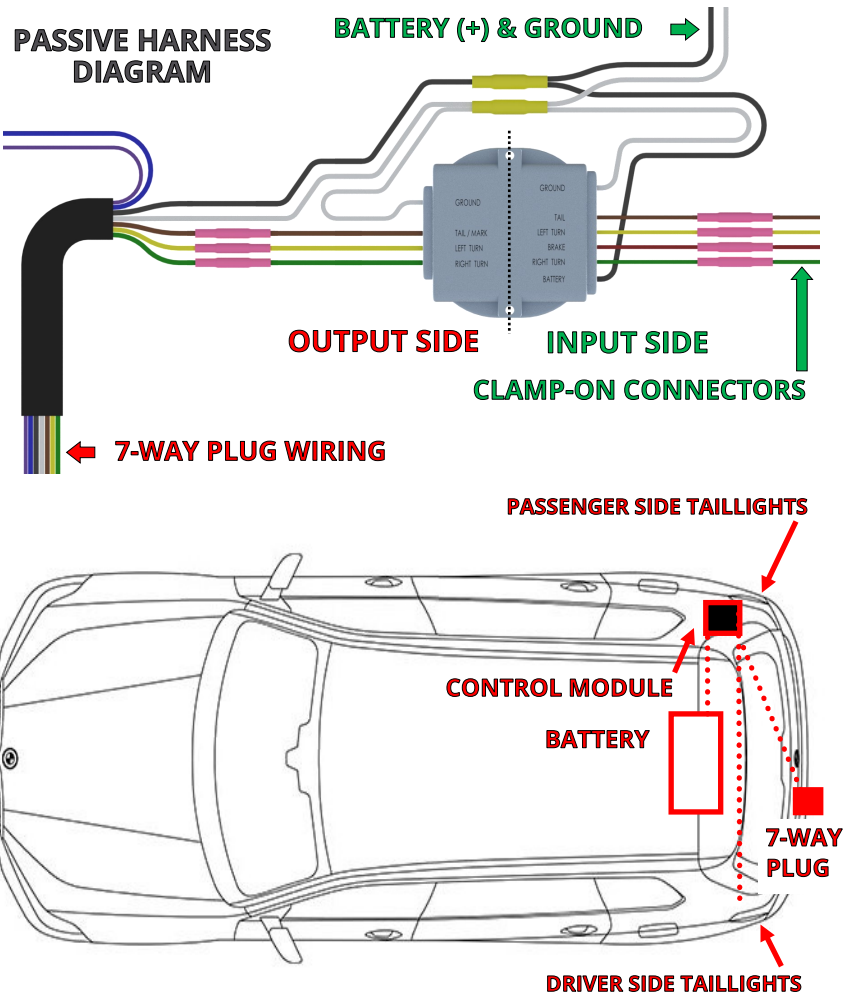

INSTALL WIRING KIT CONTINUED

22. Lift up the cargo area floor panel and prop it open. Remove (2) Styrofoam inserts. Unstrap and remove spare tire.



23. Remove the Styrofoam holder to gain access to battery compartment.

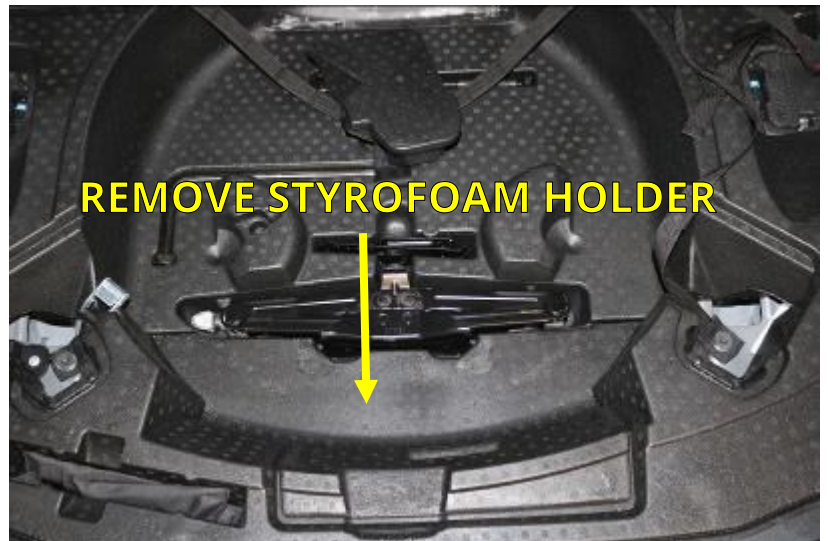

24. Remove (4) nuts holding plastic fascia support bracket on the passenger side of the vehicle.

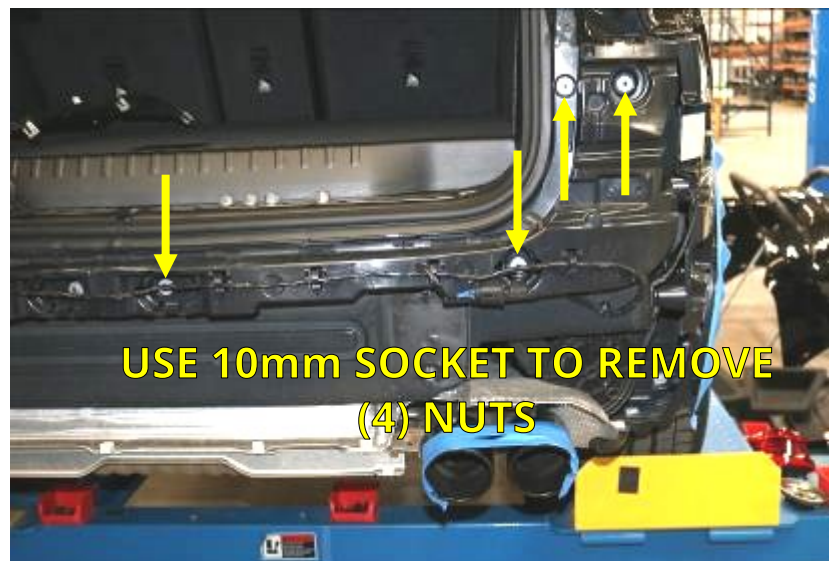

INSTALL WIRING KIT CONTINUED



DRILL &
3/8" BIT

25. Locate wiring grommet on passenger side rear of vehicle. Using one of the divots, drill a hole through grommet with a 3/8" drill bit. Make sure to drill through grommet only and not to damage harness.

NOTICE: Confirm that there is nothing inside vehicle behind grommet that can be damaged.

26. Place control module in passenger side cargo area. Feed output wires through grommet from inside to outside of vehicle.



PLIERS



MULTIMETER

27. The wires on the input side of the wiring module need to be attached to the vehicle wiring. Route the yellow wire to the driver side. Use a clamp-on connector to clamp the yellow wire to the left turn signal wire, behind taillight. (See reference tables on next page.)

Note: Vehicles may have different wire colors than those shown. Verify circuits (wire colors) with multimeter.

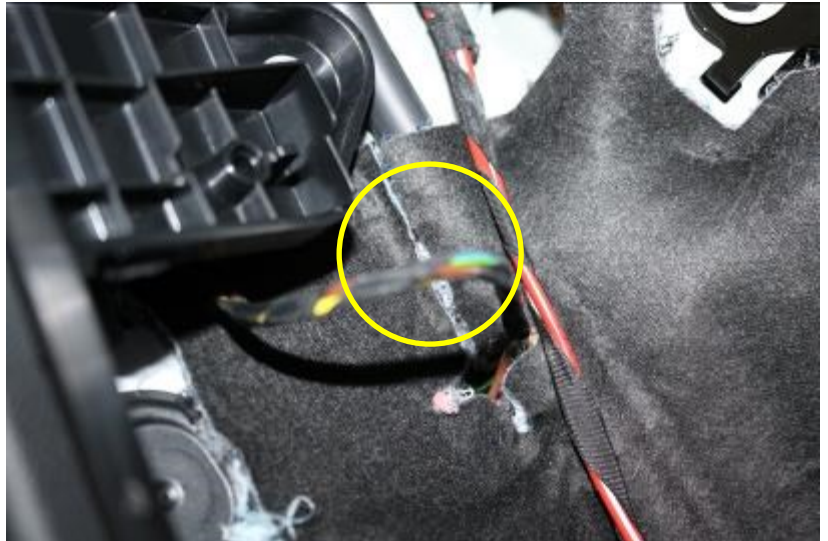

PLIERS













MULTIMETER

28. Inside the passenger side compartment, use clamp-on connectors to connect the green and brown wires to wires behind taillight. (See reference tables on next page.)



INSTALL WIRING KIT CONTINUED

CLAMP-ON CONNECTOR COLOR REFERENCE TABLE

SIGNAL INPUT WIRES			POWER & GROUND WIRES		
FUNCTION	HARNESS	VEHICLE			
LEFT TURN	 YELLOW	 GREEN/BLUE	12V+ (POWER)	 BLACK	BATTERY (+)
RIGHT TURN	 GREEN	 GREEN/GRAY	GROUND	 WHITE	GROUND STUD
MARKER	 BROWN	 GREY/YELLOW			
BRAKE	 RED	<i>Do not connect the red brake wire. This vehicle does not utilize a separate brake circuit. The brake signal is sent down the left and right turn circuits simultaneously.</i>			
REVERSE	 PURPLE	For use with trailer reverse lights or to disable the trailer brakes when backing with surge brakes. To connect, isolate vehicle's reverse light circuit and connect the purple wire from the trailer wiring harness to vehicle reverse light circuit. Trailers rarely have reverse lights or surge brakes.			
ELECTRIC BRAKE	 BLUE	Only used when a hard wired brake controller is mounted inside the vehicle and your trailer has electric brakes. See brake controller instructions for this wire.			

NOTE: If two colors are listed, the first color is the dominant color.



10mm
SOCKET

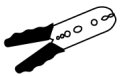

STRIPPER/
CRIMPING
TOOL

29. Locate the ground stud in the rear passenger side cargo area. Trim white ground wire so it will reach stud without excess wire. Crimp supplied fork terminal to the ground wire with a crimping tool. Loosen the ground stud and secure the fork to the ground stud.

NOTICE: Loosen ground stud just enough to install fork terminal, so vehicle wiring does not lose ground.



10mm
SOCKET



STRIPPER/
CRIMPING
TOOL

30. Locate the fuse holder supplied in the wiring kit box. Remove the fuse from fuse holder. Crimp fuse holder lead to black power wire and connect to the positive battery terminal (+).



WIRE 7-WAY PLUG



PHILLIPS HEAD
SCREWDRIVER

31. Locate the 7-way housing. Use a screwdriver to loosen (2) screws. Remove 7-way round terminal block. Place the mounting bracket onto the 7-way housing as shown. Use a screwdriver to loosen the set screw at the bottom of the 7-way housing. Route output side wires of the wiring harness through the 7-way housing.

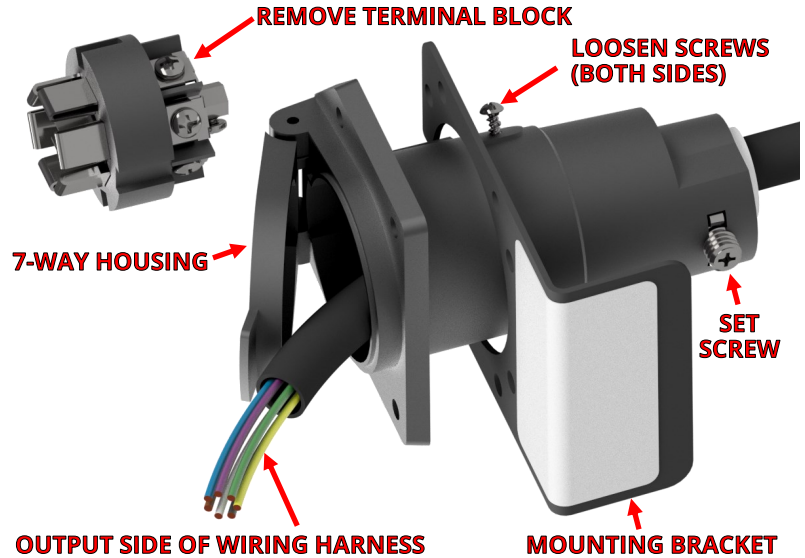

Please follow instructions below very carefully.

Incorrect wiring of the 7-way receptacle causes the vast majority of wiring problems.



PHILLIPS HEAD
SCREWDRIVER

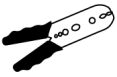

STRIPPER/
CRIMPING
TOOL

32. Locate the slot keyway. Starting from the keyway going **clockwise**, attach the wires as follows:

- Blue
- Green
- Black
- Brown
- Yellow
- White
- Purple (middle)

NOTICE: Markings on the receptacle may not match the correct wire configuration. Please disregard and follow the instruction above.

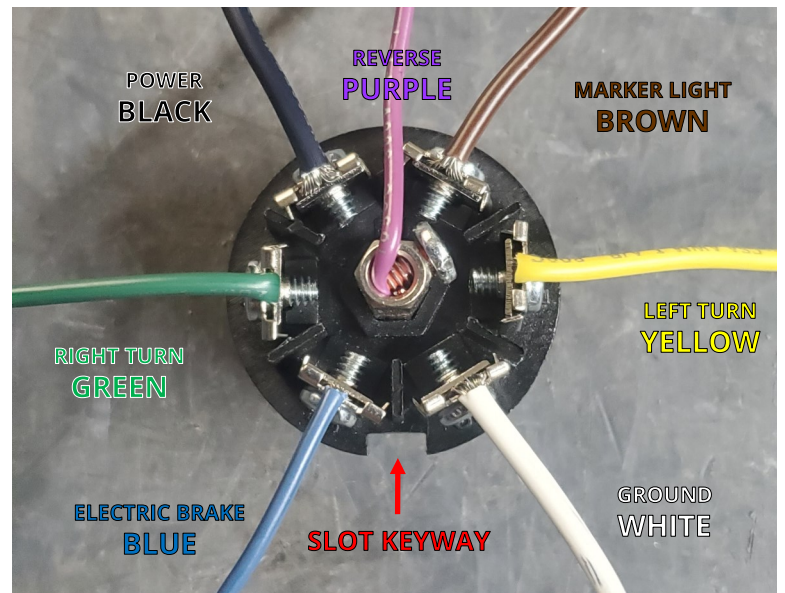

TEST 7-WAY HARNESS WIRING



PHILLIPS HEAD
SCREWDRIVER



MULTIMETER

33. Put the 7-way receptacle back together. While everything is still accessible, you should test the wiring to make sure everything is connected properly and in working order. **Replace the 20 Amp fuse into the fuse holder located near the battery.**

NOTE: Taillights will need to be temporarily plugged in during testing.

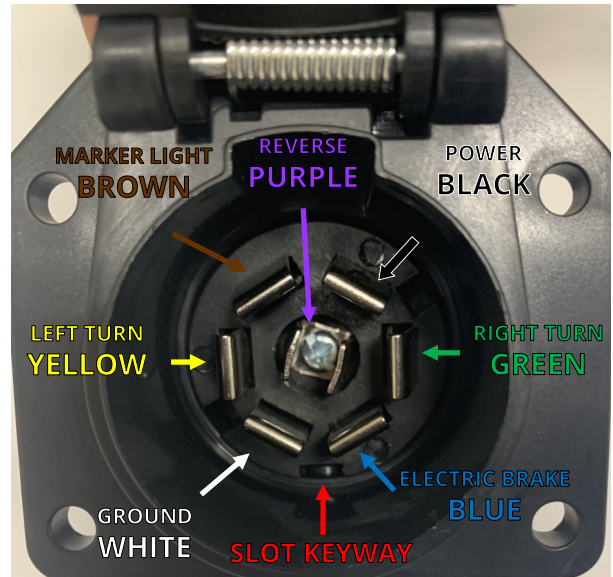

- Start by connecting the multimeter negative probe to the ground blade on the 7-way receptacle.
- Next, connect the multimeter positive probe to the power blade on the 7-way receptacle and check for 12 volts.
- Once that is confirmed, move the positive probe to the left turn blade on the 7-way receptacle and check for 12 volts when the vehicle left turn blinker is active. You should see it pulse.
- Next, move the positive probe to the right turn blade and check for 12 volts when the right turn blinker is active. You should see it pulse.
- Next, move the positive probe to the marker/taillights. With the vehicle lights on you should see 12 volts constant.
- Lastly, with the brake depressed, move the positive probe to the left turn blade where you should see 12 volts constant. Move the probe to the right turn blade where you should also see 12 volts constant.



PHILLIPS HEAD
SCREWDRIVER



SILICONE

34. Attach the mounting bracket and 7-way housing to the Stealth hitch frame as shown. Secure harness to Stealth hitch frame with cable ties.

35. Secure all wires and wiring components. Use the remaining cable ties to secure wiring so that it is not loose and will not interfere with replacement of the fascia. Wiring should not be visible once the vehicle is reassembled.

36. Use the provided adhesive foam strips to secure the control module to an inside body panel. Use silicone to waterproof the grommet.

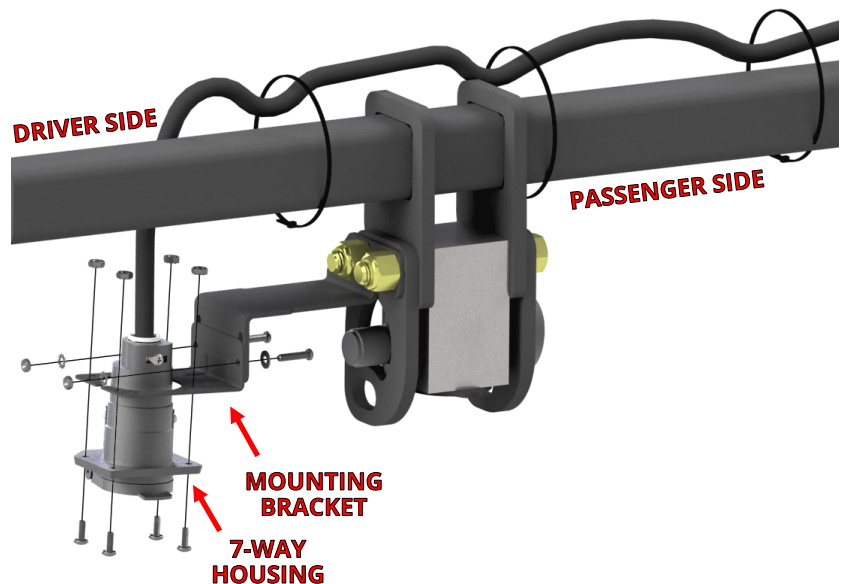

REINSTALL VEHICLE COMPONENTS

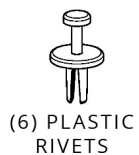

37. Reattach and secure the fascia, taillights and other vehicle components in reverse order. Refer to Steps 22-24 and 1-17.

NOTICE: Remember to plug in the sensor plug in Step 15 before reinstalling the fascia.

NOTE: Replace plastic rivets in the wheel well with supplied plastic rivets, see Step 9.



38. The finished, under vehicle view.

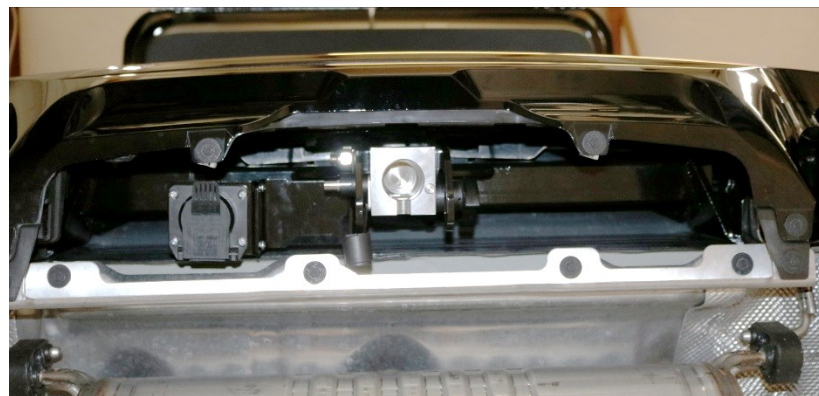

FINAL VEHICLE EXAMINATION

39. Examine the body panels to ensure that they are in a pre-installation condition. Test the electronic functions of the vehicle. Correct any inconsistencies.
40. Ensure that hitch components work properly.
 - **Verify that the lock works correctly.** Push in the safety lock on the latch block then unlock with key. The lock should slide back out with the key when unlocked.
 - **Verify that each accessory can be installed correctly.** Use the following steps to install and remove each accessory that will be used with the hitch. (*Rack Receiver and Ball Mount if purchased.*)
 1. Prepare latching mechanism. Turn handle clockwise if needed.
 2. Firmly insert "post" of accessory into latch block until handle releases indicating that the accessory is latched.
 3. Push in the safety locking pin until it fully engages. The locking pin prevents the handle from turning when pushed in, and confirms that the block is securely latched onto the accessory. The safety locking pin will not depress if the accessory is not fully latched.
 4. Use key to release safety locking pin.
 5. While holding on to the accessory, rotate handle clockwise to release and remove the accessory.
 - **Verify that no part of the accessories come into contact with the body of the vehicle.**

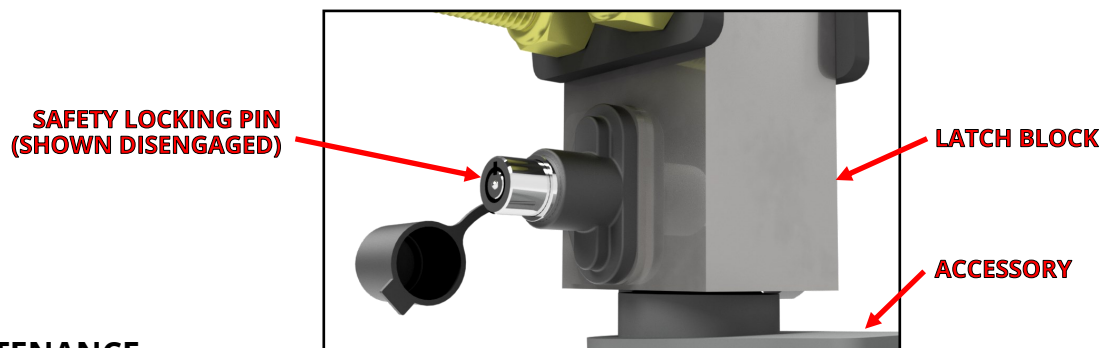

PRODUCT USE AND MAINTENANCE

NOTICE: If the hitch is being installed by a professional, the installer is responsible for training the end user in the use and maintenance of the product.

- **Accessory installation procedure:**
 1. Prepare latching mechanism. Turn handle clockwise if needed.
 2. Firmly insert "post" of accessory into latch block until handle spins counter-clockwise indicating that the accessory is latched.
 3. Always depress the safety locking pin and check that it has fully engaged.
- **Never use any accessory with the safety lock disengaged.** Until the safety locking pin is engaged, the handle is able to turn. A fully engaged safety locking pin is confirmation that the accessory is properly latched into the latch block.
- **Never use the rack receiver for towing.** The rack receiver accessory is only to be used with payload carrying products, such as bike racks or luggage racks.
- **Before each use, give the post of the accessory a light coating of lithium based grease.**
- **Before each use, inspect the hitch to ensure that all bolted connections are secure and that no cracks or damage are present.** Do not tow with the hitch if cracks or damage outside of normal wear is found.
- **Remove the Stealth accessories from the latch block after each use.** Do not leave accessories plugged in for extended periods of time.