



www.stealthhitches.com 833-694-4824

HITCH INSTALLATION INSTRUCTIONS

MAKE:	YEARS:	MODEL/TRIM:
BMW	2018-2024	X3 - M40i
	2018-2024	X3 - 30i s/xDrive & M-sport
	2020-2024	X3 - 30e xDrive Hybrid
	2016-2018	X4 - M40i (SHT25023)

RACK RECEIVER KIT#: **SHR31019**

COMPATIBLE WITH TOW KITS: **SHT25008, SHT25023, & SHT25013A**

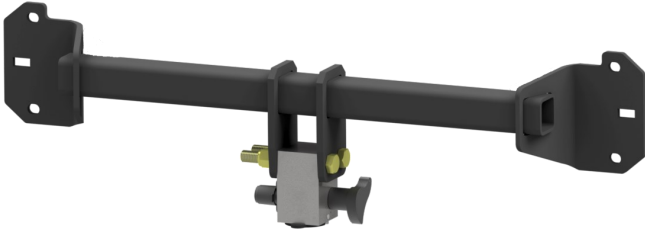

2" RACK RECEIVER MAXIMUM PAYLOAD: 600 LBS
MAXIMUM TOW RATING: 6000 LBS
MAXIMUM TONGUE WEIGHT: 600 LBS

UNDER VEHICLE TRIMMING:

HEAT SHIELD: **NO**
 FASCIA: **NO**
 GRAVEL GUARD TRIMMING: **YES**



READ ALL INSTRUCTION WARNINGS AND LABELS



NO WELDING, METAL DRILLING OR VISIBLE TRIMMING REQUIRED

PARTS SUPPLIED WITH RACK KIT:

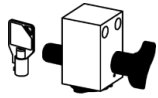

LATCH BLOCK & KEYS



(2) BOLTS
5/8"-11 x 5"



(2) 5/8" NYLOCK NUTS



2" RACK RECEIVER



(6) PLASTIC RIVETS

ADDITIONAL PARTS FOR TOW KIT:

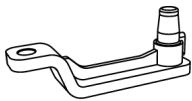

BALL MOUNT
5" RISE, SHORT



CHAIN HOOKS

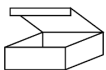

PASSIVE OR **ACTIVE**
WIRING KIT BOX



2" BALL

TOOLS REQUIRED:



15/16" OPEN
END WRENCH



18mm DEEP WELL,
8mm, 10mm, 13 mm
& 15/16" SOCKETS



RATCHET

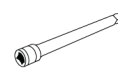

SOCKET
EXTENSION



TORQUE
WRENCH



FLASHLIGHT



PLASTIC
PRY TOOLS



PAINTER'S TAPE



SAFETY GLASSES



90 DEGREE
PICK



TIN SNIPS
(X3 ONLY)



DREMEL TOOL
(X4 ONLY)



FILE
(X4 ONLY)

ADDITIONAL TOOLS FOR **ACTIVE** & **PASSIVE** TOW KITS:

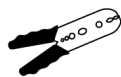

STRIPPER/
CRIMPING
TOOL



MULTIMETER



PHILLIPS HEAD
SCREWDRIVER



FLATHEAD
SCREWDRIVER



DRILL &
3/8" BIT



SILICONE



RAZOR KNIFE
(**ACTIVE** ONLY)

ADDITIONAL TOOLS FOR **PASSIVE** TOW KIT:



PLIERS



T30 TORX
(X4 ONLY)

RACK RECEIVER INSTALLATION: USE STEPS 1-25, & 55-61
PASSIVE TOW KIT INSTALLATION: USE STEPS 1-43, & 51-61
ACTIVE TOW KIT INSTALLATION: USE STEPS 1-33, & 44-61

NOTICE: If installing an **ACTIVE tow kit, the vehicle must be programmed before trailer lights will function, see notice on Page 3.**

<THESE INSTRUCTIONS MUST BE GIVEN TO THE END USER>

NOTICE: Installation of Stealth products may or may not require the addition of a wiring harness to the vehicle.

- The Rack Receiver only product does not require adding a wiring harness.
- The Rack Receiver plus Tow Kit requires the addition a wiring harness that is compatible with the vehicle's wiring. Depending on the vehicle, the harness will be one of two types, "Active" or "Passive." The wiring section of the instructions will indicate which wiring harness style is being used and how to install it.
- The **Active Harness** plugs into the vehicle's wiring so that the vehicle's computer can communicate with the trailer wiring. This allows certain functions such as cameras or backup alarms to continue to operate as designed. Some active harnesses require reprogramming of the vehicle's computer before the trailer wiring is functional. For BMW vehicles that need programming, Stealth provides this service remotely. Refer to the Active Harness section of the instructions to determine if programming is required for this install. ***This programming must be taken into account when planning the timing of the Stealth product install. The remote BMW programming needs to be scheduled approximately 1 week in advance.***
- The **Passive Harness** is independent of the vehicle's computer and communication system. The module of the harness is powered directly from the battery rather than the vehicle's wiring harness. The module monitors the output signals from the vehicle's lights. It then powers and activates the trailer lighting accordingly.









INSTALLATION NOTE: In most instances, these instructions will only outline disassembly of vehicle components. Re-installation of components will require the installer to retain vehicle hardware and work through disassembly instructions in reverse order. When installation is complete, double check that all vehicle components have been replaced and are secured.

IMPORTANT SAFETY NOTICE FOR STEALTH HITCH INSTALLERS AND CUSTOMERS.

Read all installation and operating instructions along with all labels before installing or using this product. Do not perform any installation or towing procedures without fully understanding the correct tools and actions for all steps. Call for support if needed.

WARNING

Failure to comply with the safety information in these instructions could result in serious injury or death.

-  Do not modify this product in any manner. Doing so could alter its integrity and lead to a loss of attachment between the trailer and the tow vehicle.
-  Adding Stealth hitch components to the chassis of any vehicle can be hazardous. There is potential for unexpected combustion of fuel, electric shock, burns, shifting or falling of unstable vehicle, damage to vehicle, injury from tool usage and many other hazards. This installation must be completed by someone who is aware of the hazards involved. This person must be knowledgeable of proper safety procedures for a vehicle modification of this nature, and for usage of the equipment required to perform the installation.
-  Without proper knowledge, towing can be a dangerous activity. Understand all the risks involved with towing before proceeding. For information on towing safety, see "**The Trailer Handbook: A Guide to Understanding Trailer and Towing Safety**" from the National Association of Trailer Manufacturers, www.NATM.com and your trailer and tow vehicle manufacturer's owner's manual.
-  Do not exceed tow or tongue rating of coupler, tow or tongue rating of hitch, or tow or weight ratings of tow vehicle or trailer. See vehicle and trailer manufacturer information for ratings. Exceeding these ratings may cause damage to towing components or loss of attachment between the trailer and vehicle.
-  While installation is being performed, check for signs of damage or excessive corrosion. Do not install hitch components over vehicle parts that are broken or have compromised structural integrity.
-  This product was designed to fit vehicles in their original, "as manufactured" condition. Compatibility with vehicles having replacement parts, or other modifications is not guaranteed. Inspect vehicle for modifications before installation of this product.
-  Some accessories, like the rack receiver, are not rated for towing. Do not use any accessories without proper knowledge of their use.
-  A visual inspection of the hitch should be performed before each use. Regularly check that all connections are secure, including those that secure the hitch to the vehicle. Check for cracks or damage to the hitch. Do not use the hitch if cracks or damage outside of normal wear is found. Using a hitch that has unsecure connections and/or cracks or damage could result in damage to the tow vehicle, trailer, towing components and loss of attachment between the tow vehicle and trailer.
-  Stealth hitches are not compatible with any weight distribution or sway control products. Adding additional products to the trailer or chassis which modifies the function of the Stealth hitch may cause hitch failure.

NOTICE: Installation of hitch requires removal of vehicle parts and interaction with vehicular electronics. Before installation, check the condition of body panels and note any locations where panels are not flush. Check the electronic functions of the vehicle, such as: headlights, taillights, turn signals, cameras, backup sensors, Parking Distance Controller (PDC), foot activated cargo access, etc. It is the responsibility of the installer to restore the fit and function of the vehicle.

NOTICE: If installing an active wiring harness, your vehicle must be programmed. Arrangements can be made with Code My Car (585-496-4648). Please allow at least a week to make programming arrangements. Programming will require your vehicle to be connected to a computer and an internet connection. **Note:** A programming code is affixed to the control module and the programming cord which will be needed when contacting Code My Car. Additional programming changes may be available at time of programming. Arrangements can be made when contacting Code My Car.

GAIN ACCESS TO MOUNTING AREA

1. **X3 only** Open vehicle cargo area and remove driver and passenger side panels for access to rear of the taillights.



PLASTIC
PRY TOOLS



10mm
SOCKET

2. Next to the taillight, slide plastic cover upward to remove.

NOTICE: X3 only Use a plastic pry tool to remove plastic rivet before sliding cover upward.

3. Remove (2) nuts attaching the taillight to the vehicle with a socket.



GAIN ACCESS TO MOUNTING AREA CONTINUED



10mm
SOCKET

4. **X3 only** Locate and remove third screw holding taillight inside the vehicle.
5. Locate and unplug taillight wiring by pushing down on "release clip" then pulling outward.



IF INSTALLING HITCH ON 2022 VEHICLE MODELS - SKIP STEP 6 & 7.

NOTICE: If the rear reflectors are vertical instead of horizontal skip Steps 6 & 7. Do not remove the reflectors if they are vertical.



PLASTIC
PRY TOOLS

6. **2021 and older models.** Remove rear reflector. On some vehicles, the center clip securing the reflector is easily accessible from underneath the vehicle. If so, push upwards to rear of vehicle to remove the reflector. If it is not easily accessible, pry the reflector with a plastic pry tool starting in the center of the vehicle, working outwards.

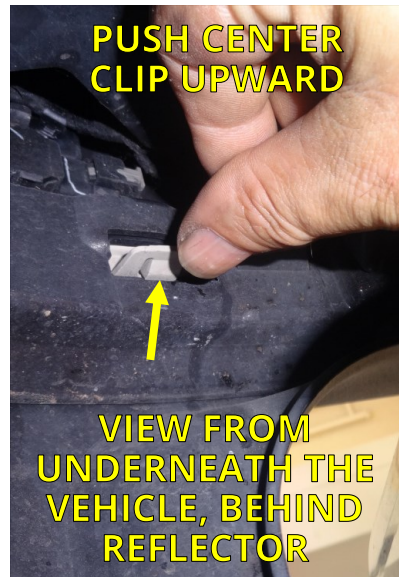

8mm
SOCKET

7. **2021 and older models.** A screw will be exposed when the reflector is removed. Use a socket to remove screw. Repeat Steps 2-7 on other side of vehicle.



GAIN ACCESS TO MOUNTING AREA CONTINUED



PLASTIC PRY TOOLS



90 DEGREE PICK



8mm SOCKET



PLASTIC PRY TOOLS



8mm SOCKET



PAINTER'S TAPE

8. Locate the rivets inside the rear wheel wells. Use a 90 degree pick or a pry tool to remove (3) most rearward plastic rivets. The rivets secure the wheel well trim to the vehicle.

NOTE: Make sure not to damage the wheel well trim piece.

NOTE: Replacement plastic rivets are supplied.

- **2022 M-sport and M40i Vehicle models only.** Use a 8mm socket to remove screw holding the bottom of the wheel well trim.

9. To allow partial removal of the rear wheel well trim (3) clips will need to be released. Apply outward pressure on the wheel well trim. Start with the bottom clip and work up. Push down on clip to disconnect. Use plastic pry tools on hard to reach clips.

10. Behind the rear wheel well trim are (2) screws holding the fascia. Pull the trim away from vehicle to expose screws. Use a socket to remove the screws. Repeat Steps 8-10 on other side of vehicle.

NOTE: To protect the trim from being scratched during the removal or replacement, cover it with painter's tape or something similar.

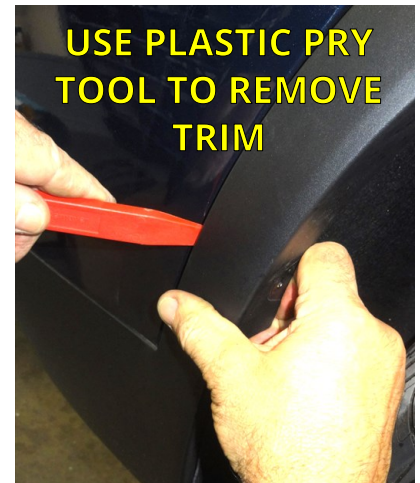

GAIN ACCESS TO MOUNTING AREA CONTINUED



8mm
SOCKET

11. **X3 only** Use a socket to remove screw holding fascia that was exposed by removing taillight.



8mm
SOCKET

-or-



10mm
SOCKET

12. **X3 only** Underneath the vehicle, use a socket to remove (10) screws from the gravel guard. (blue arrows)
13. **X3 only** Remove (4) screws from the rear edge of the fascia. (green arrows)



8mm
SOCKET

-or-



10mm
SOCKET

14. **X3 only** Use a socket to remove (6) screws from the outer edges of the fascia.



GAIN ACCESS TO MOUNTING AREA CONTINUED



8mm
SOCKET



10mm
SOCKET

15. **X4 only** Underneath the vehicle, use a socket to remove (7) screws from the edges of the fascia. (purple arrows)

16. **X4 only** Remove (4) nuts to detach the gravel guard. (green arrows)

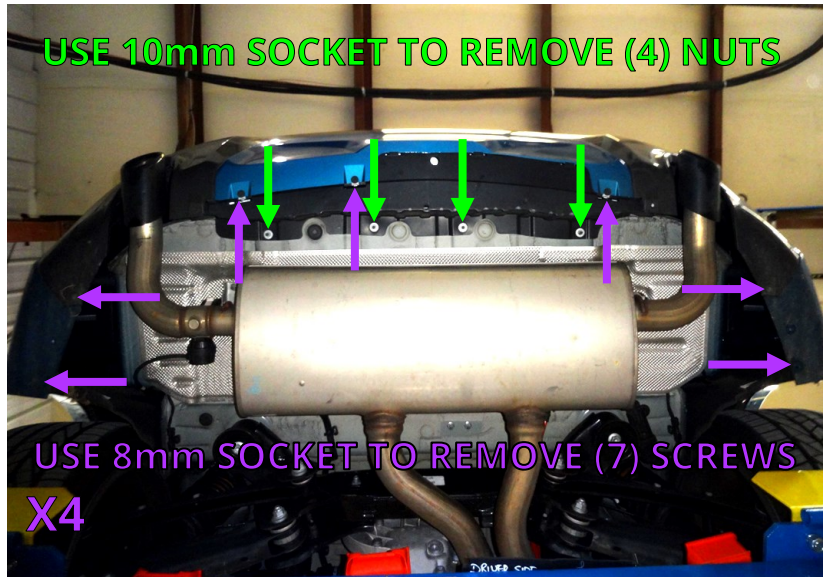

17. **X4 only** Pull gravel guard down to remove.



PLASTIC
PRY TOOLS

18. The fascia is clipped to the vehicle body directly behind the wheel wells. Pull outward on the fascia to expose the first clip in the seam. With a plastic pry tool, push down on the exposed clip to disconnect. Continue to pull outward on the fascia and disconnect clips as they are exposed until all the clips are released. Repeat on other side of vehicle.

NOTE: X3 will look slightly different.

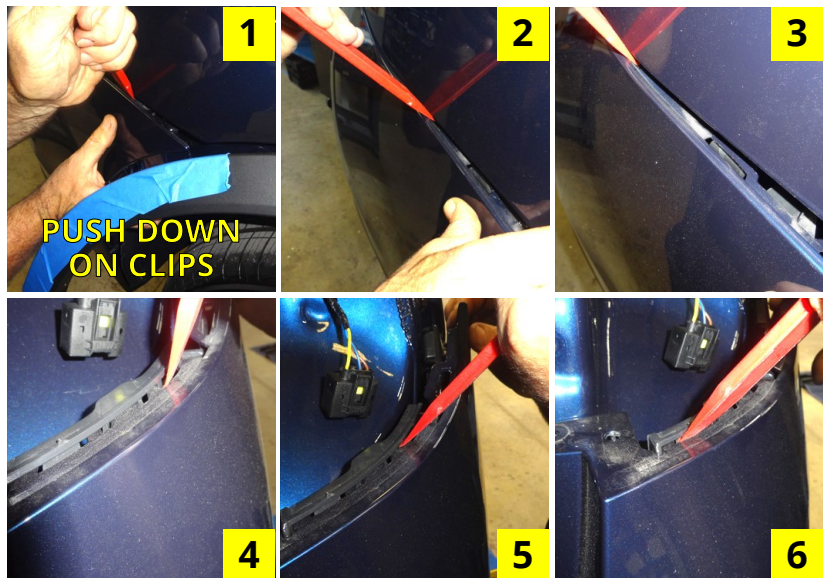

GAIN ACCESS TO MOUNTING AREA



90 DEGREE PICK

19. This step requires a partner. Pull the fascia rearward enough to access the PDC sensor plug on the passenger side. Use a 90 degree pick to open the clip and unplug the PDC sensor plug. Remove the fascia completely.

NOTICE: Carefully remove the fascia and place on a blanket or pad.

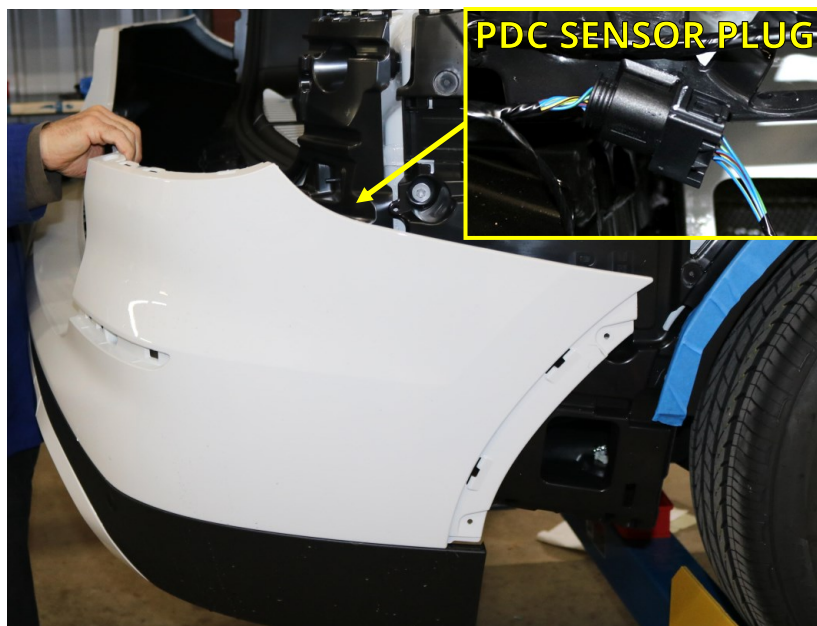

13mm SOCKET

20. **X3 only** Locate the two exhaust brackets under the rear of the vehicle, above the muffler. Use a socket to remove (1) exhaust bracket nut on each side of the vehicle.



90 DEGREE PICK

21. Remove (6) plastic rivets from plastic insert securing it to the factory reinforcement beam. Do not disconnect the wires connected to plastic insert. Save the rivets for reinstallation.



GAIN ACCESS TO MOUNTING AREA CONTINUED



22. Remove (4) nuts from factory reinforcement beam and remove factory reinforcement beam. Save the reinforcement beam and (4) nuts for reinstallation.

NOTICE: If installing on an X4 M40i (2016-2018) The reinforcement beam will not be reinstalled in Step 23, and may be discarded.

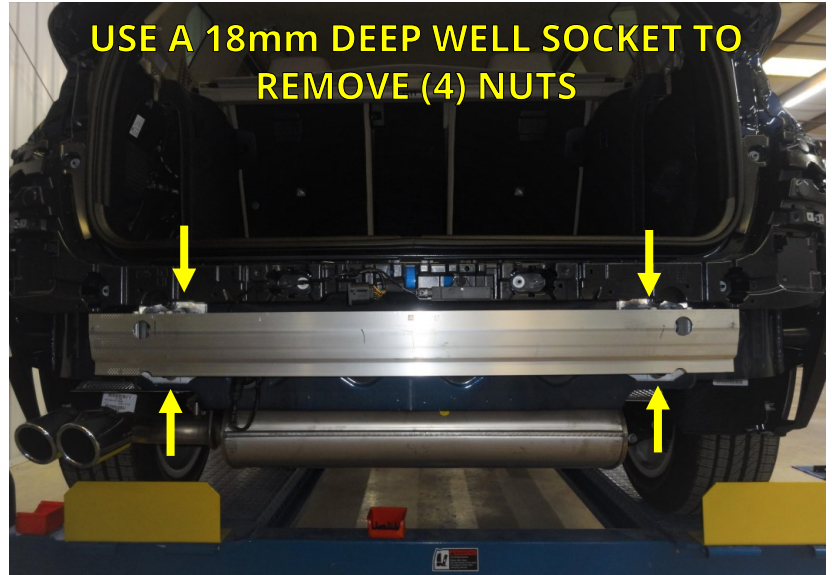

INSTALL STEALTH HITCH FRAME

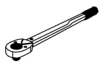

TORQUE
WRENCH

23. Install the Stealth hitch frame and factory reinforcement beam onto the vehicle studs. Use the (4) nuts saved from the factory reinforcement beam. Center the hitch frame and beam before tightening. Use a torque wrench to tighten the nuts to 85 ft.-lbs.

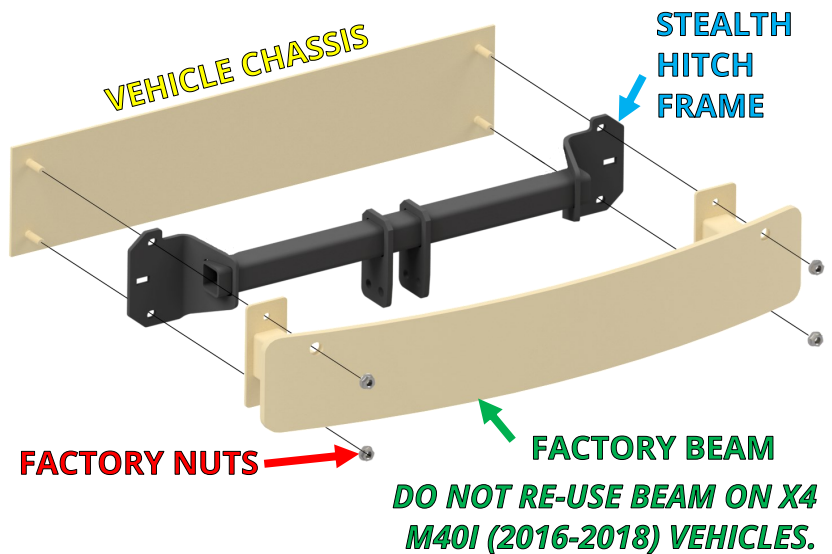

24. Reinstall the plastic insert secured to the factory reinforcement beam.



MOUNT LATCH BLOCK



15/16" SOCKET



15/16" OPEN END WRENCH



TORQUE WRENCH

25. Installation of the latch block varies depending on which kit you are installing.

- **Rack Receiver Kit:** Install the latch block with (2) 5/8"-11 x 5" bolts and (2) 5/8" nylock nuts. Tighten each bolt to 150 ft.-lbs.
- **Tow Kit:** Retrieve Z-bracket (X3) or C-bracket (X4) from wiring harness kit box. Install the latch block, (2) chain hooks, and bracket with (2) 5/8"-11 x 5" bolts and (2) 5/8" nylock nuts. Tighten each bolt to 150 ft.-lbs.

NOTICE: Keys are packaged within the latch block, remove keys and store in safe location.

RACK RECEIVER KIT INSTALL



X3 PASSIVE & ACTIVE TOW KIT INSTALL

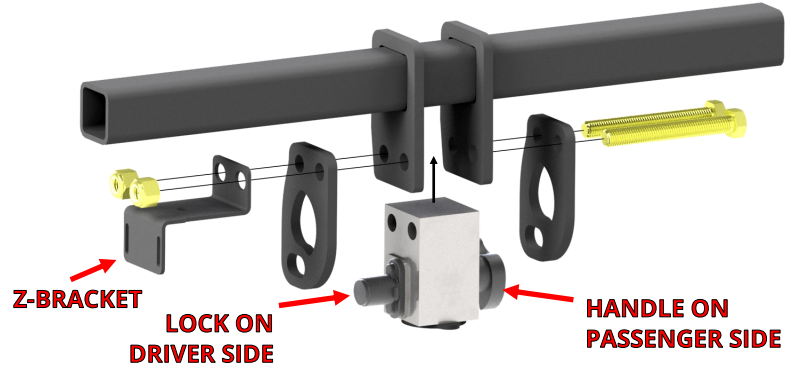

X4 TOW KIT INSTALL

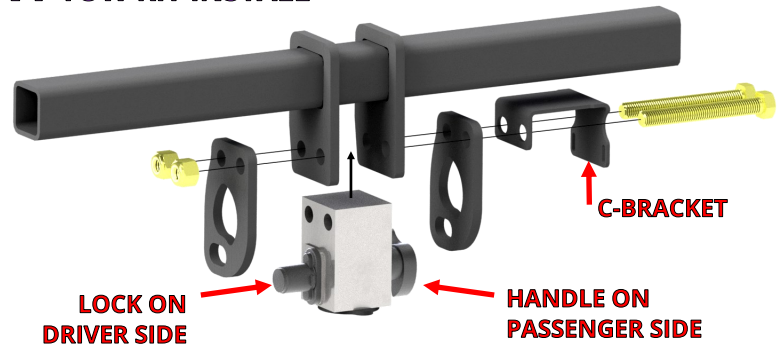

IF INSTALLING A RACK RECEIVER KIT, SKIP TO STEP 55.
IF INSTALLING A TOW KIT, CONTINUE TO STEP 26.

INSTALL WIRING KIT



26. Locate the wiring kit box. Review the contents of the box against the list below to check for missing components.

- **The passive wiring kit** uses a control module to manage the functions of the trailer lighting. The module has an “input” side that receives power from the vehicle’s battery and signals from the vehicle’s taillights. The “output” side of the module delivers this information to the 7-way plug, *see passive harness diagram*. The control module is connected to the vehicle’s battery and taillight wiring as outlined in the next steps.
- **The active wiring kit** uses a BMW computer control module to manage the functions of the trailer lighting. The module must be “programmed” before it will be functional. The module will connect to the vehicle through an included wire harness. The harness has an “input” side that receives power and signals from the vehicle’s electronic systems. The “output” side of the harness delivers this information to the 7-way plug. The harness and computer module installation are outlined in the next steps.

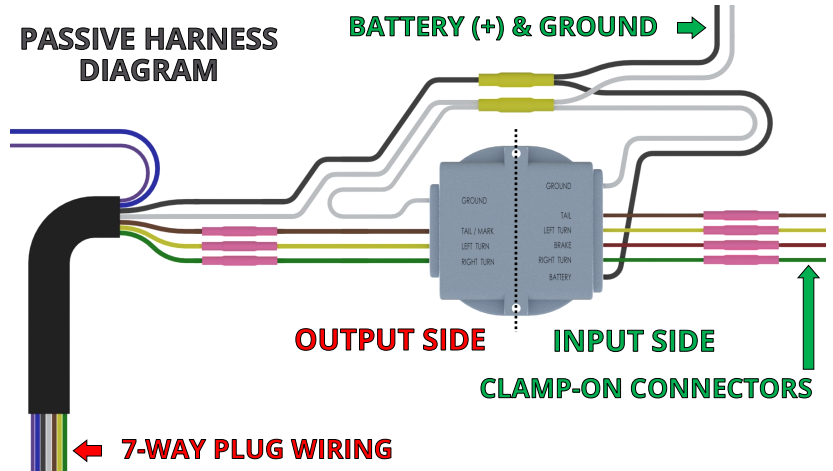

NOTICE: Do not allow electrical system to become disconnected from power or ground. Doing so may interrupt electrical systems.

PASSIVE WIRING KIT BOX

PASSIVE WIRING KIT BOX ITEMS

#	DESCRIPTION	X3 QTY	X4 QTY
1	7-WAY WIRING HARNESS <ul style="list-style-type: none"> • FUSE HOLDER & FUSE • CONTROL MODULE & WIRES 	1	1
2	ADHESIVE FOAM STRIP	2	2
3	FORK TERMINAL	1	1
4	5/8" LONG PHILLIPS SCREWS	4	6
5	#10 LOCK NUT	4	6
6	CLAMP-ON CONNECTORS	5	5
7	CABLE TIE - 8"	4	8
8	CABLE TIE - 14"	3	3
9	Z-BRACKET	1	
10	C-BRACKET		1
11	MOUNTING BRACKET	1	1
12	7-POLE HOUSING	1	1
13	7-POLE TO 4-POLE ADAPTER	1	1

ACTIVE WIRING KIT BOX



ACTIVE WIRING KIT BOX ITEMS

#	DESCRIPTION	QTY
1	BMW WIRING HARNESS	1
2	BMW CONTROL MODULE	1
3	7-WAY CONNECTOR CABLE	1
4	VEHICLE PROGRAMMING CABLE	1
5	5/8" LONG PHILLIPS SCREWS	6
6	#10 LOCK NUT	6
7	CABLE TIE - 8"	4
8	CABLE TIE - 14"	2
9	CABLE TIE - 8" (BUNDLE)	10
10	Z-BRACKET	1
11	MOUNTING BRACKET	1
12	7-POLE HOUSING	1
13	7-POLE TO 4-POLE ADAPTER	1

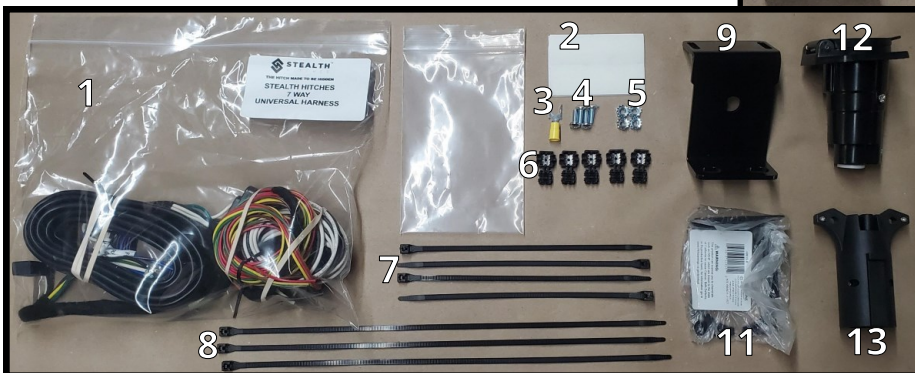

INSTALL WIRING KIT CONTINUED



90 DEGREE PICK



T30 TORX

27. **X4 only** Inside the rear cargo area, remove both rear side cargo panels. Next, Remove the plastic cargo holder on the passenger side of the cargo area by removing (2) plastic rivets with a 90 degree pick. Use a Torx to remove (1) screw.

NOTE: Save rivets for reinstallation.



28. Lift up the cargo area floor panel.



29. In the floor of the rear cargo area, remove (2) plastic screws with a flathead screwdriver.

30. **X4 only** Remove (4) plastic rivets under floor panel using 90 degree pick, as shown.

NOTE: X3 will look slightly different.



90 DEGREE PICK



INSTALL WIRING KIT CONTINUED

31. Lift up to gain access to battery compartment.

NOTE: X3 will look slightly different.



32. Some vehicle models may have insulation behind each taillight. If present, Fold back to gain access to rear taillight wiring harness.



33. X3 only Remove (4) nuts holding plastic fascia support bracket on the passenger side of the vehicle.



10mm
SOCKET

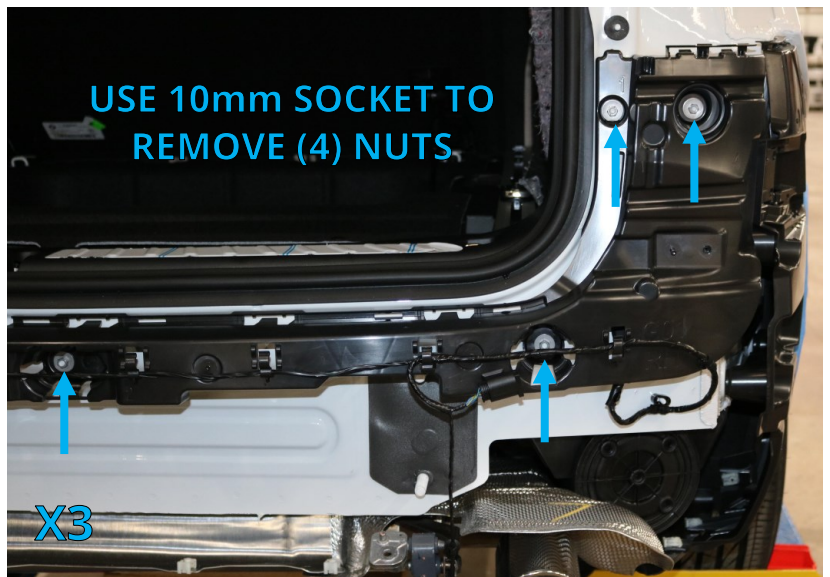

IF INSTALLING AN **ACTIVE** WIRING HARNESS, SKIP TO STEP 44.
IF INSTALLING A **PASSIVE** WIRING HARNESS, CONTINUE TO STEP 34.

INSTALL PASSIVE WIRING KIT



DRILL &
3/8" BIT

34. Locate wiring grommet on passenger side rear of vehicle. Use a 3/8" drill bit to drill a hole through grommet. Make sure to drill through grommet only and not to damage harness. Use the factory dimple location in the grommet to drill the hole.

NOTICE: Confirm that there is nothing inside vehicle behind grommet that can be damaged.

35. Place control module in passenger side cargo area. Feed output wires through grommet from inside to the outside of the vehicle.

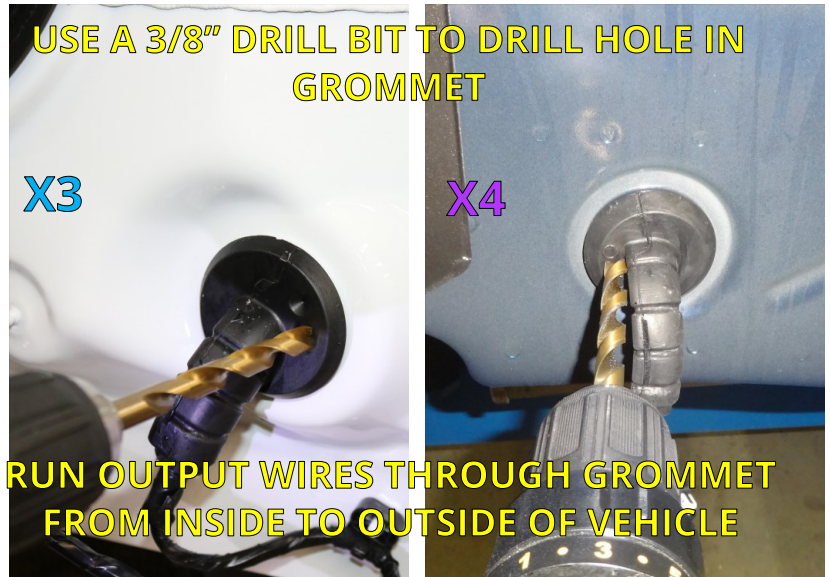

PLIERS



MULTIMETER

36. The wires on the input side of the wiring module need to be attached to the vehicle wiring. Route the yellow wire to the driver side. Use a clamp-on connector to clamp the yellow wire to the left turn signal wire, behind taillight. (See reference tables on next page.)

Note: Vehicles may have different wire colors than those shown. Verify circuits (wire colors) with multimeter.

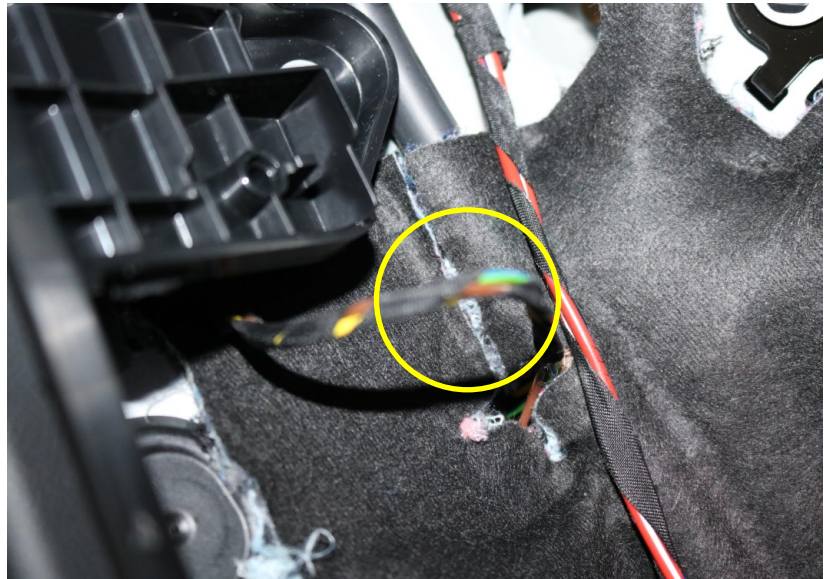

PLIERS











MULTIMETER



37. Inside the passenger side compartment, use clamp-on connectors to connect to wires behind taillight. (See reference tables on next page.)













X3 CLAMP-ON CONNECTOR COLOR REFERENCE TABLE

SIGNAL INPUT WIRES			POWER & GROUND WIRES		
FUNCTION	HARNESS	VEHICLE			
LEFT TURN	 YELLOW	 GREEN/BLUE	12V+ (POWER)	 BLACK	BATTERY (+)
RIGHT TURN	 GREEN	 GREEN/GRAY	GROUND	 WHITE	GROUND STUD
MARKER	 BROWN	 GRAY/YELLOW			
BRAKE	 RED	<i>Do not connect the red brake wire. This vehicle does not utilize a separate brake circuit. The brake signal is sent down the left and right turn circuits simultaneously.</i>			



X4 WITH XENON LIGHTS CLAMP-ON CONNECTOR COLOR REFERENCE TABLE

SIGNAL INPUT WIRES			POWER & GROUND WIRES		
FUNCTION	HARNESS	VEHICLE			
LEFT TURN	 YELLOW	 BLUE/GREEN	12V+ (POWER)	 BLACK	BATTERY (+)
RIGHT TURN	 GREEN	 BLUE/BROWN	GROUND	 WHITE	BATTERY (-)
MARKER	 BROWN	 YELLOW/PURPLE			
BRAKE	 RED	 BLUE/BLACK			

X4 WITHOUT XENON LIGHTS CLAMP-ON CONNECTOR COLOR REFERENCE TABLE

SIGNAL INPUT WIRES			POWER & GROUND WIRES		
FUNCTION	HARNESS	VEHICLE			
LEFT TURN	 YELLOW	 BLUE/GREEN	12V+ (POWER)	 BLACK	BATTERY (+)
RIGHT TURN	 GREEN	 BLUE/BROWN	GROUND	 WHITE	BATTERY (-)
MARKER	 BROWN	 GRAY/PURPLE			
BRAKE	 RED	 BLACK/YELLOW			

ALL VEHICLES CLAMP-ON CONNECTOR COLOR REFERENCE TABLE

REVERSE	 PURPLE	For use with trailer reverse lights or to disable the trailer brakes when backing with surge brakes. To connect, isolate vehicle's reverse light circuit and connect the purple wire from the trailer wiring harness to vehicle reverse light circuit. Trailers rarely have reverse lights or surge brakes.
ELECTRIC BRAKE	 BLUE	Only used when a hard wired brake controller is mounted inside the vehicle and your trailer has electric brakes. See brake controller instructions for this wire.

NOTE: If two colors are listed, the first color is the dominant color.

INSTALL PASSIVE WIRING KIT CONTINUED



10mm
SOCKET



STRIPPER/
CRIMPING
TOOL

38. **X3 only** Locate the ground stud in the rear passenger side cargo area. Trim white ground wire so it will reach stud without excess wire. Crimp supplied fork terminal to the ground wire with a crimping tool. Loosen the ground stud and secure the fork to the ground stud.

NOTICE: Loosen ground stud just enough to install fork terminal, so vehicle wiring does not lose ground.



10mm
SOCKET

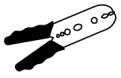

STRIPPER/
CRIMPING
TOOL

39. **X4 only** Trim white ground wire so it will reach the negative battery terminal (-) without excess wire. Crimp supplied fork terminal to the ground wire with a crimping tool. Connect ground wire to negative battery terminal (-). Replace the nut and tighten.

NOTICE: Do not allow vehicle wiring to lose ground contact.



10mm
SOCKET

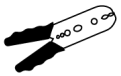

STRIPPER/
CRIMPING
TOOL

40. Locate the fuse holder supplied in the wiring kit box. Remove the fuse from fuse holder. Crimp fuse holder lead to black power wire and connect to the positive battery terminal (+).

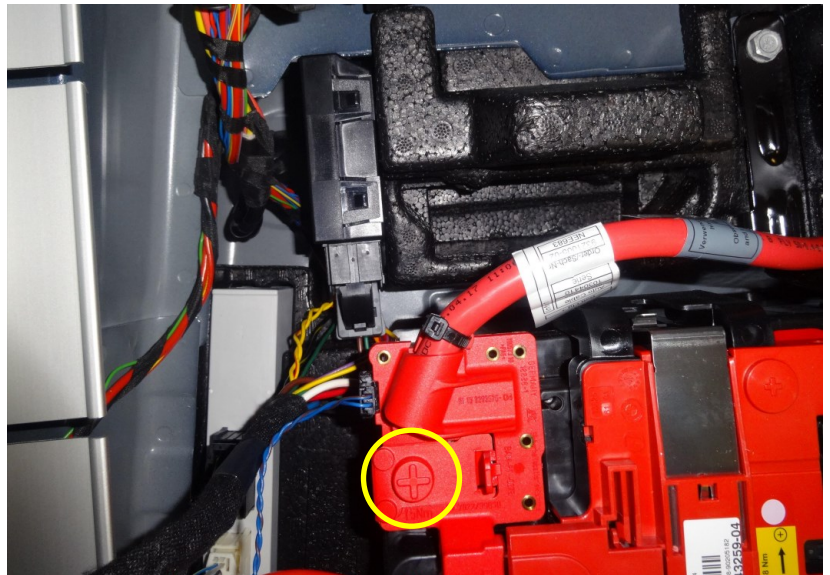

WIRE 7-WAY PLUG



PHILLIPS HEAD
SCREWDRIVER

41. Locate the 7-way housing. Use a screwdriver to loosen (2) screws. Remove 7-way round terminal block. Place the mounting bracket onto the 7-way housing as shown. Use a screwdriver to loosen the set screw at the bottom of the 7-way housing. Route output side wires of the wiring harness through the 7-way housing.

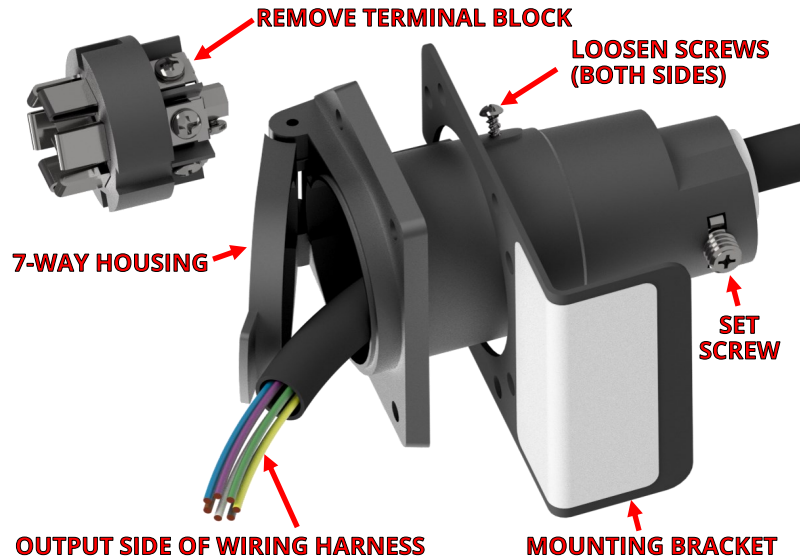

Please follow instructions below very carefully.

Incorrect wiring of the 7-way receptacle causes the vast majority of wiring problems.



PHILLIPS HEAD
SCREWDRIVER

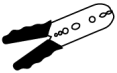

STRIPPER/
CRIMPING
TOOL

42. Locate the slot keyway. Starting from the keyway going **clockwise**, attach the wires as follows:

- Blue
- Green
- Black
- Brown
- Yellow
- White
- Purple (middle)

NOTICE: Markings on the receptacle may not match the correct wire configuration. Please disregard and follow the instruction above.

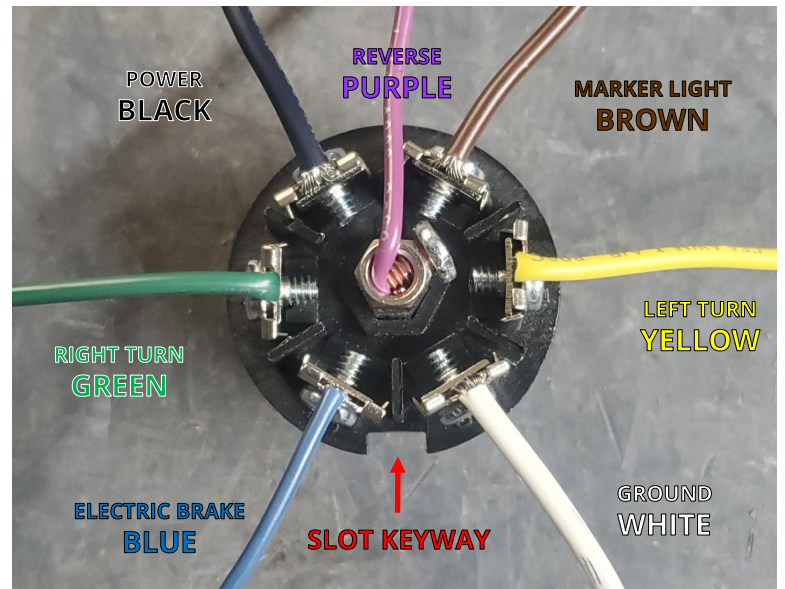

PHILLIPS HEAD
SCREWDRIVER

43. Put the 7-way receptacle back together. **Replace the 20 Amp fuse into the fuse holder located near the battery.**



Skip to Step 51 to complete installation.

INSTALL **ACTIVE** WIRING KIT



DRILL &
3/8" BIT

44. Locate wiring grommet on passenger side rear of vehicle. Use a 3/8" drill bit to drill a hole through grommet. Make sure to drill through grommet only and not to damage harness. Use the factory dimple location in the grommet to drill the hole.

NOTICE: Confirm that there is nothing inside vehicle behind grommet that can be damaged.



RAZOR KNIFE

45. After drilling the hole through the grommet. Remove the grommet and cut a slit from the drilled hole to the outside edge of the grommet. Locate the BMW wiring harness in the wiring kit box. From the inside of the vehicle pass the output plugs through the hole where the grommet was seated, see image in next step. Push the wiring harness wire into the slit in the grommet and then replace the grommet.

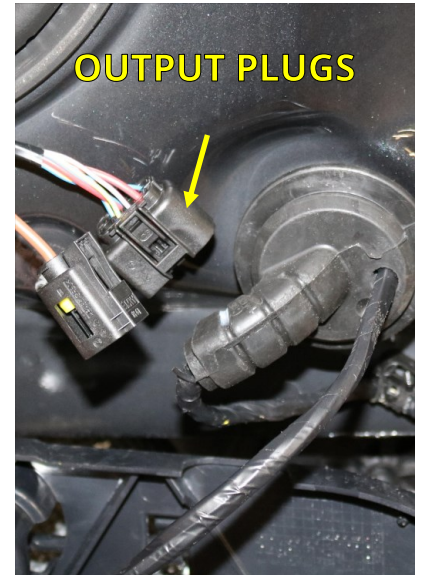

46. Locate the 7-way connector cable in the wiring kit box. Plug the two square plugs from the 7-way connector into the BMW wiring harness.

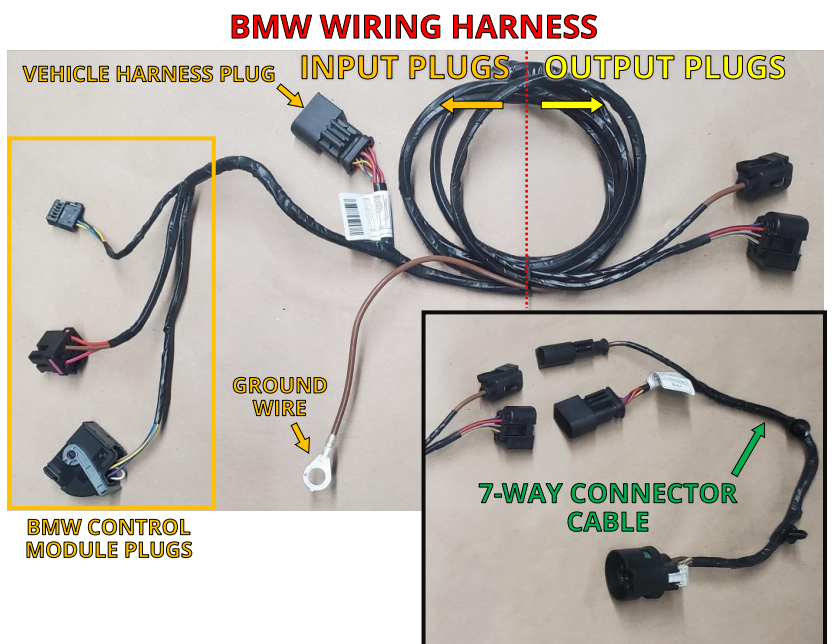

INSTALL **ACTIVE** WIRING KIT CONTINUED



10mm
SOCKET

47. Inside the vehicle, locate the ground stud in the rear passenger side cargo area and the grounding ring on the BMW wiring harness. Carefully remove the ground stud and at the same time, keep the wires grounded here in continuous contact with the stud. Place the ground ring connector over the stud. Replace the nut and tighten.

NOTICE: Do not allow vehicle wiring to lose ground contact.



48. Plug the BMW trailer harness into the vehicle harness plug on the passenger side.

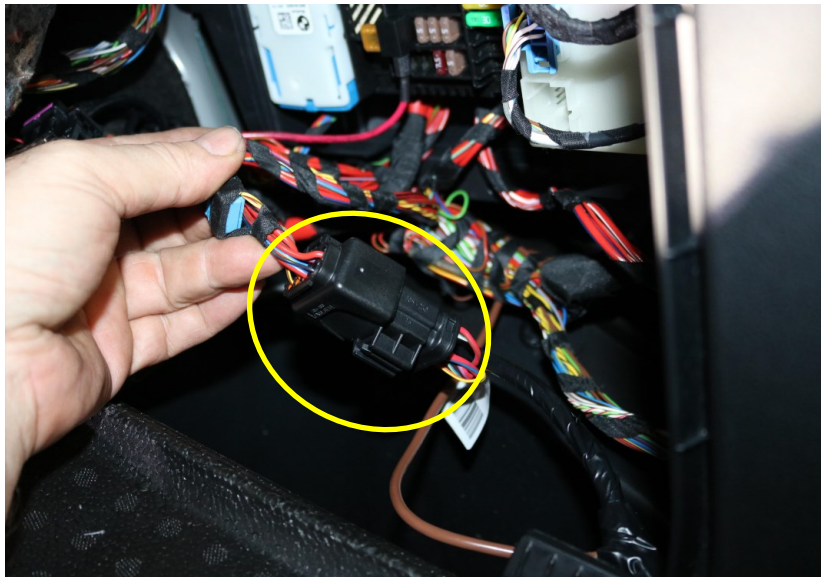

49. In the active wiring kit box locate the BMW control module. Plug the (24) pin connector into the control module and lock it with the lock clip in first slot, as shown. Plug the (6) pin and (10) pin connectors in the control module in the next two slots, as shown.

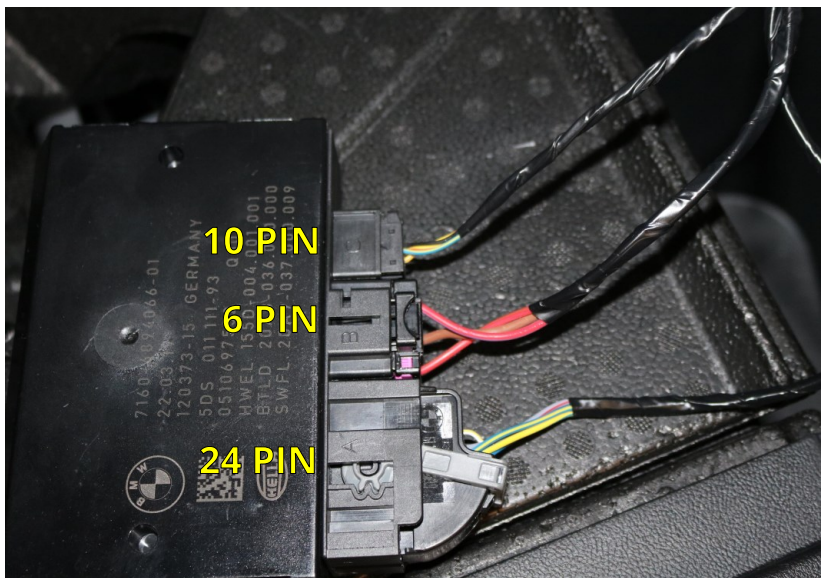

INSTALL **ACTIVE** WIRING KIT CONTINUED

50. Insert the control module into the slot shown in the fuse panel.

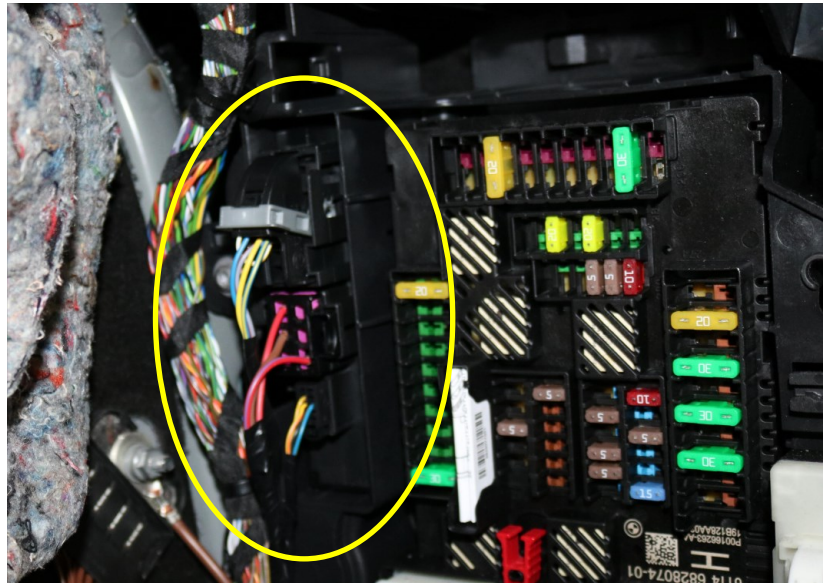

TEST 7-WAY HARNESS WIRING



PHILLIPS HEAD
SCREWDRIVER



MULTIMETER

51. While everything is still accessible, you should test the wiring to make sure everything is connected properly and in working order. **If installing the passive harness, replace the 20 Amp fuse into the fuse holder located near the battery.**

NOTICE: Most **Active** harness installations will require programming before testing can be completed. Testing Active wiring harness installations with a multimeter or LED tester may not work. Some vehicles may need to "sense" the current being used by the plug to function. After programming is complete, use an incandescent light testing device or trailer to test in these specific cases.

NOTE: Taillights will need to be temporarily plugged in during testing.

- Start by connecting the multimeter negative probe to the ground blade on the 7-way receptacle.
- Next, connect the multimeter positive probe to the power blade on the 7-way receptacle and check for 12 volts.
- Once that is confirmed, move the positive probe to the left turn blade on the 7-way receptacle and check for 12 volts when the vehicle left turn blinker is active. You should see it pulse.
- Next, move the positive probe to the right turn blade and check for 12 volts when the right turn blinker is active. You should see it pulse.
- Next, move the positive probe to the marker/taillights. With the vehicle lights on you should see 12 volts constant.
- Lastly, with the brake depressed, move the positive probe to the left turn blade where you should see 12 volts constant. Move the probe to the right turn blade where you should also see 12 volts constant.

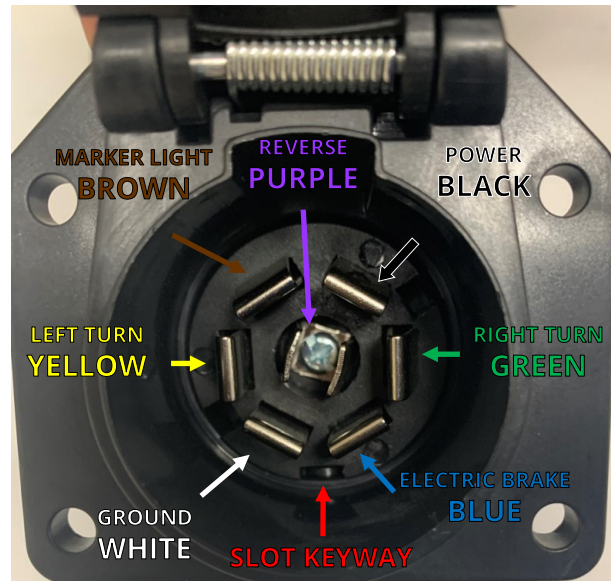

ATTACH 7-WAY HARNESS WIRING



PHILLIPS HEAD
SCREWDRIVER



SILICONE

52. Attach the mounting bracket and 7-way housing to the Stealth hitch frame as shown. Secure harness to Stealth hitch frame with cable ties.
53. Secure all wires and wiring components. Use the remaining cable ties to secure wiring so that it is not loose and will not interfere with replacement of the fascia. Wiring should not be visible once the vehicle is reassembled.
54. Waterproof grommet with silicone. If installing passive wiring kit, use the provided adhesive foam strips to secure the control module to an inside body panel.

X3 PASSIVE TOW KIT INSTALL

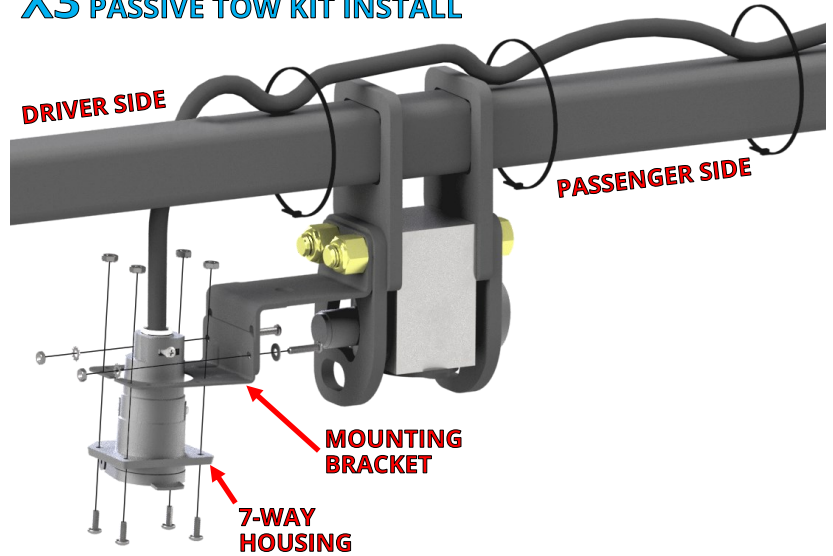

X4 PASSIVE TOW KIT INSTALL

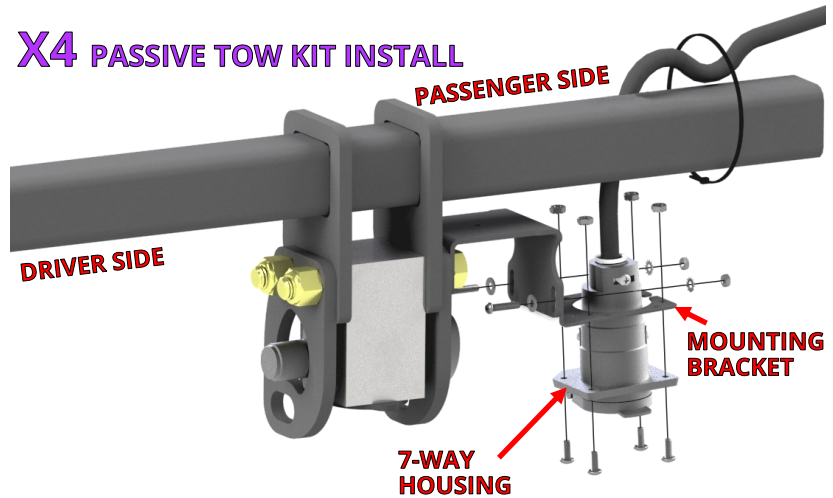

ACTIVE TOW KIT INSTALL

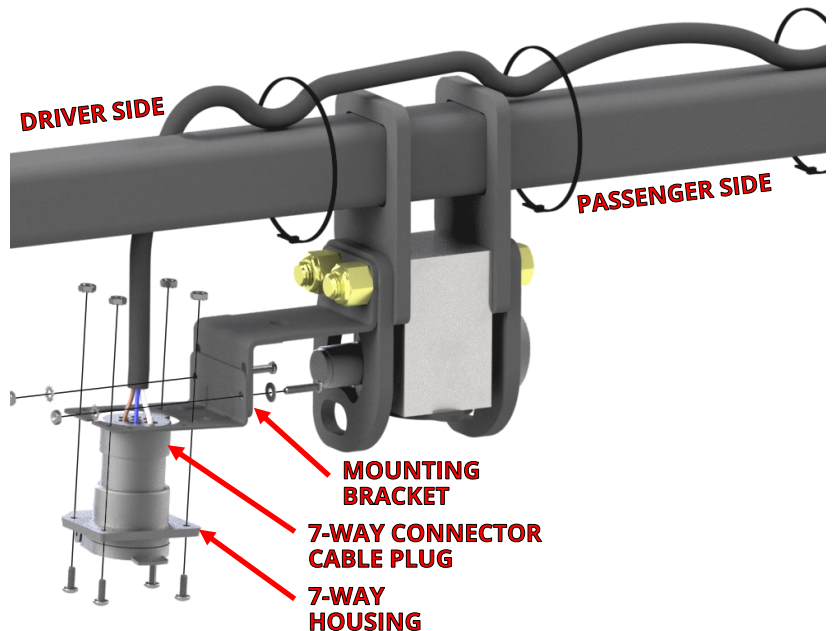

CUT ACCESS HOLE IN GRAVEL GUARD



TIN SNIPS

55. **X3 only** Cut out the gravel guard with tin snips, as shown.

X3 RACK RECEIVER KIT

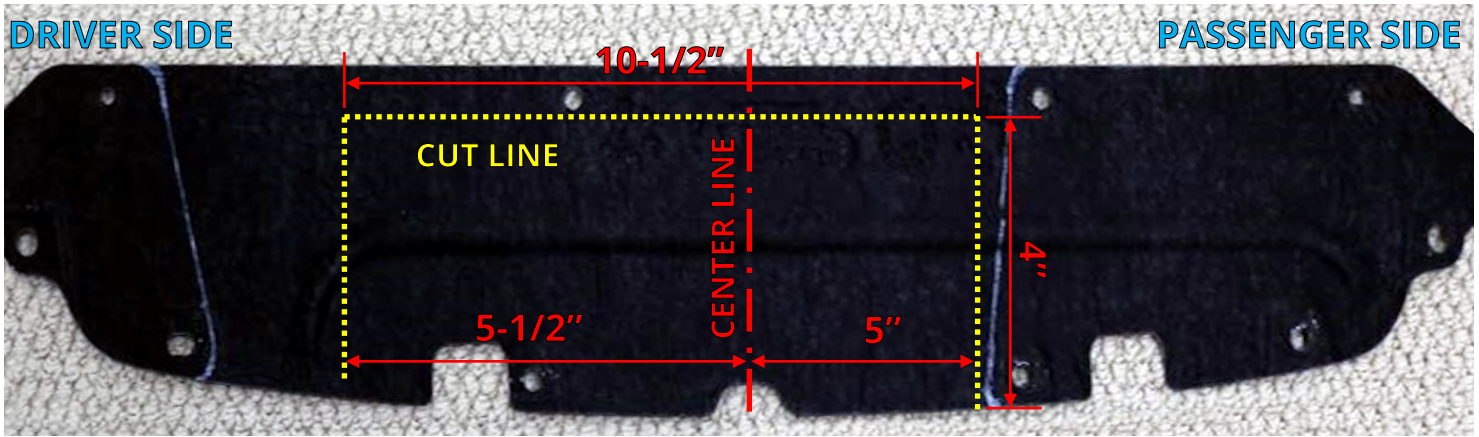

X3 TOW KIT (PASSIVE AND ACTIVE)

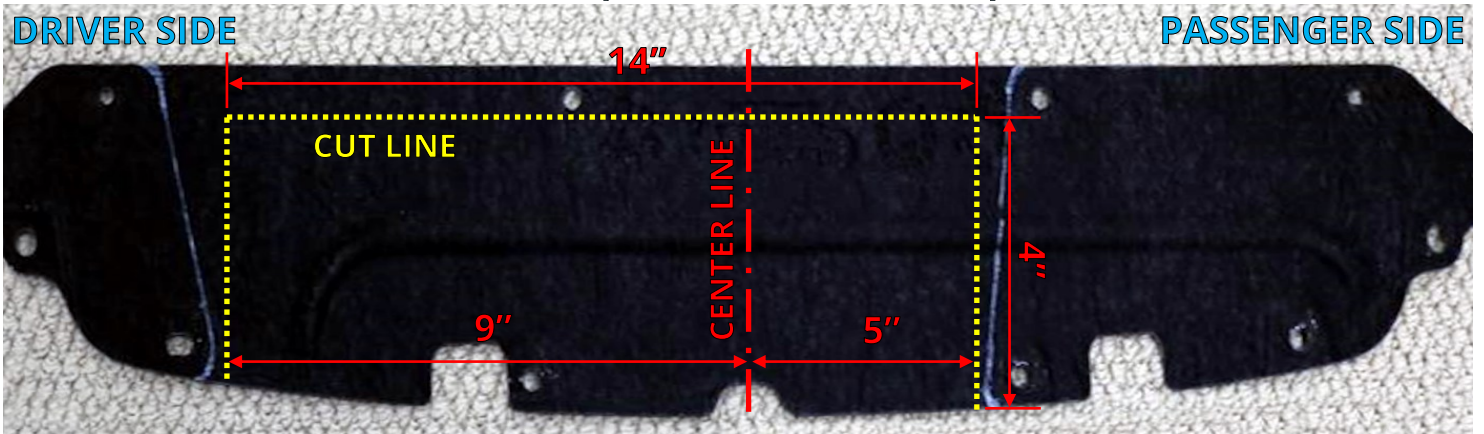

DREMEL TOOL



FILE

56. **X4 only** Cut out the gravel guard with Dremel tool. Use a file to smooth out the cut.

- **Rack receiver kit:** Cut the right side of the center line to **6"**, making the cutout a total of **13"** wide.
- **Tow kit:** Cut the right side of the center line to **9"**, making the cut out **16"** wide.

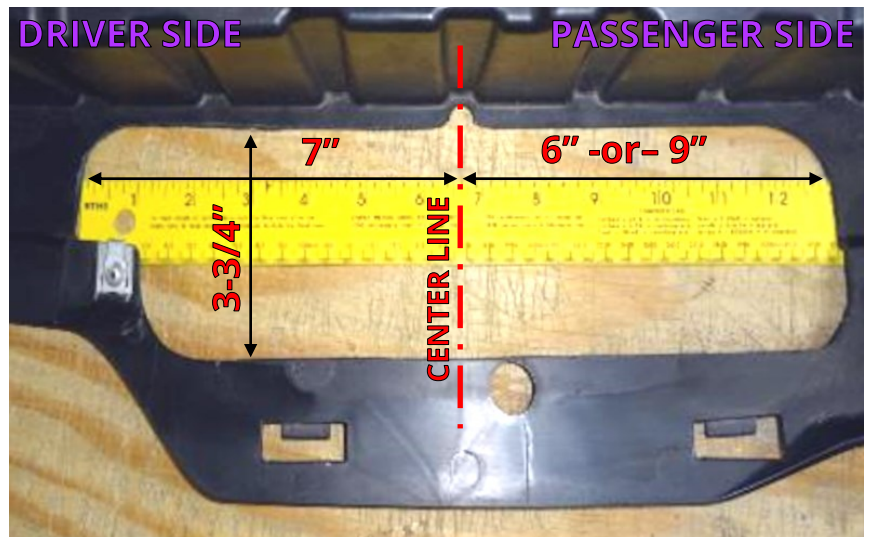

NOTE: IMAGE SHOWS RACK RECEIVER CUTOUT

REINSTALL VEHICLE COMPONENTS



10mm
SOCKET

57. **X3 only** Replace the plastic fascia support bracket removed in Step 33.
58. If installing the tow kit, reinstall the side panels, cargo holder, and floor panel in reverse order. Refer Steps 27-32.

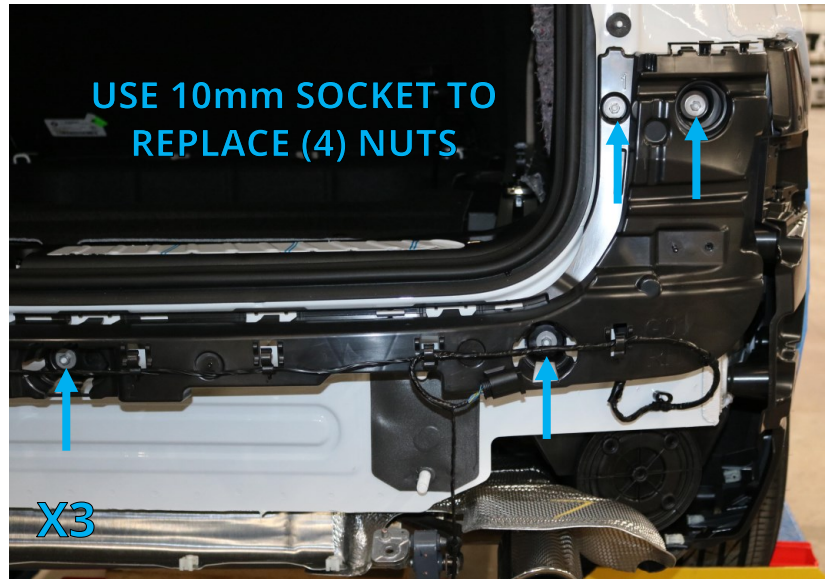

(6) PLASTIC
RIVETS

59. Reattach and secure the fascia, taillights and other vehicle components in reverse order. Refer to Steps 1-21.

NOTICE: Remember to plug in the sensor plug in Step 19 before reinstalling the fascia.

NOTE: Replace plastic rivets in the wheel well with supplied plastic rivets, see Step 8.



FINAL VEHICLE EXAMINATION

60. Examine the body panels to ensure that they are in a pre-installation condition. Test the electronic functions of the vehicle. Correct any inconsistencies.
61. Ensure that hitch components work properly.
 - **Verify that the lock works correctly.** Push in the safety lock on the latch block then unlock with key. The lock should slide back out with the key when unlocked.
 - **Verify that each accessory can be installed correctly.** Use the following steps to install and remove each accessory that will be used with the hitch. (*Rack Receiver and Ball Mount if purchased.*)
 1. Prepare latching mechanism. Turn handle clockwise if needed.
 2. Firmly insert "post" of accessory into latch block until handle releases indicating that the accessory is latched.
 3. Push in the safety locking pin until it fully engages. The locking pin prevents the handle from turning when pushed in, and confirms that the block is securely latched onto the accessory. The safety locking pin will not depress if the accessory is not fully latched.
 4. Use key to release safety locking pin.
 5. While holding on to the accessory, rotate handle clockwise to release and remove the accessory.
 - **Verify that no part of the accessories come into contact with the body of the vehicle.**

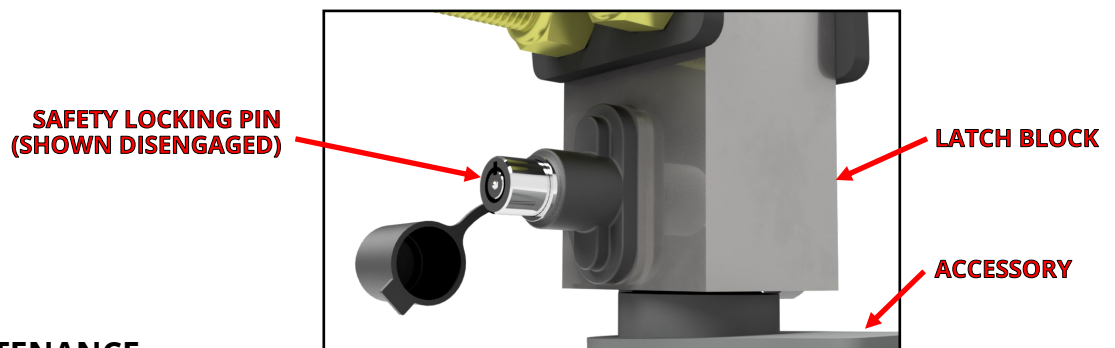

PRODUCT USE AND MAINTENANCE

NOTICE: If the hitch is being installed by a professional, the installer is responsible for training the end user in the use and maintenance of the product.

- **Accessory installation procedure:**
 1. Prepare latching mechanism. Turn handle clockwise if needed.
 2. Firmly insert "post" of accessory into latch block until handle spins counter-clockwise indicating that the accessory is latched.
 3. Always depress the safety locking pin and check that it has fully engaged.
- **Never use any accessory with the safety lock disengaged.** Until the safety locking pin is engaged, the handle is able to turn. A fully engaged safety locking pin is confirmation that the accessory is properly latched into the latch block.
- **Never use the rack receiver for towing.** The rack receiver accessory is only to be used with payload carrying products, such as bike racks or luggage racks.
- **Before each use, give the post of the accessory a light coating of lithium based grease.**
- **Before each use, inspect the hitch to ensure that all bolted connections are secure and that no cracks or damage are present.** Do not tow with the hitch if cracks or damage outside of normal wear is found.
- **Remove the Stealth accessories from the latch block after each use.** Do not leave accessories plugged in for extended periods of time.