



www.stealthhitches.com 833+694+4824

HITCH INSTALLATION INSTRUCTIONS

MAKE: BMW **YEARS:** 2012 - 2015 **MODEL/TRIM:** X1 (E84 CHASSIS)
 2007 - 2013 M3 (E90 CHASSIS)

RACK RECEIVER KIT#: **SHR31012**

COMPATIBLE WITH TOW KITS: **SHT25002 & SHT25000**

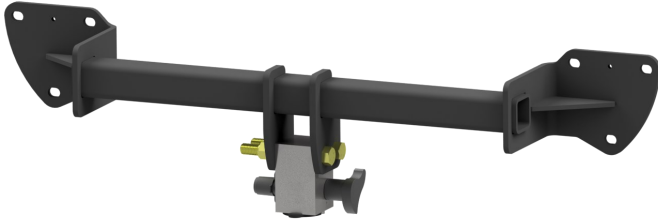

2" RACK RECEIVER MAXIMUM PAYLOAD: 350 LBS
MAXIMUM TOW RATING: 3500 LBS
MAXIMUM TONGUE WEIGHT: 350 LBS

UNDER VEHICLE TRIMMING:

HEAT SHIELD: **NO**
 FASCIA: **YES**
 GRAVEL GUARD TRIMMING: **YES**
 (X1 only)



READ ALL INSTRUCTION WARNINGS AND LABELS



NO WELDING, METAL DRILLING OR VISIBLE TRIMMING REQUIRED

PARTS SUPPLIED WITH RACK RECEIVER KIT:

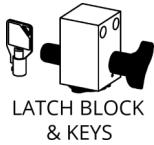

LATCH BLOCK & KEYS



(2) BOLTS
5/8"-11 x 5"



(2) 5/8"
NYLOCK NUTS



2" RACK RECEIVER

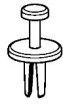

(6) PLASTIC RIVETS
(X1 only)

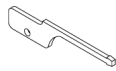

EXHAUST BRACKET
(X1 only)

ADDITIONAL PARTS FOR TOW KIT:



BALL MOUNT
5" RISE, SHORT
(X1 only)



BALL MOUNT
7" RISE, SHORT
(M3 only)



CHAIN HOOKS



2" BALL

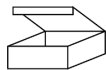

PASSIVE WIRING
KIT BOX

TOOLS REQUIRED:



15/16" OPEN
END WRENCH



18mm DEEP WELL,
8mm, & 15/16"
SOCKETS



RATCHET

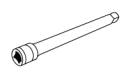

SOCKET
EXTENSION



TORQUE
WRENCH



SAFETY GLASSES



FLASHLIGHT



PLASTIC
PRY TOOLS



90 DEGREE
PICK



DREMEL TOOL



T20
(X1 only)

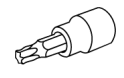

T25 TORX
(M3 only)



FILE

ADDITIONAL TOOLS FOR TOW KIT:



STRIPPER/
CRIMPING
TOOL



MULTIMETER



SILICONE



10mm
SOCKET



RAZOR KNIFE



PLIERS



13mm
SOCKET
(M3 only)



SIDE
CUTTERS
(M3 only)



T40 TORX
(X1 only)

M3 RACK RECEIVER INSTALLATION: USE STEPS 1-5, 13, 15-16, 18-19, 38-39, & 41-42
M3 TOW KIT INSTALLATION: USE STEPS 1-5, 13, 15-16, 18-20, 25-35, 38-39, & 41-42
X1 RACK RECEIVER INSTALLATION: USE STEPS 6-19, 36-37, & 39-42
X1 TOW KIT INSTALLATION: USE STEPS 6-24, 26-37, & 39-42

<THESE INSTRUCTIONS MUST BE GIVEN TO THE END USER>

NOTICE: Installation of Stealth products may or may not require the addition of a wiring harness to the vehicle.

- The Rack Receiver only product does not require adding a wiring harness.
- The Rack Receiver plus Tow Kit requires the addition of a "Passive" wiring harness to the vehicle. The passive harness "reads" the output of the vehicle's lights and translates the signals to the trailer without being connected to the vehicle computer.

INSTALLATION NOTE: In most instances, these instructions will only outline disassembly of vehicle components. Re-installation of components will require the installer to retain vehicle hardware and work through disassembly instructions in reverse order. When installation is complete, double check that all vehicle components have been replaced and are secured.

IMPORTANT SAFETY NOTICE FOR STEALTH HITCH INSTALLERS AND CUSTOMERS.

Read all installation and operating instructions along with all labels before installing or using this product. Do not perform any installation or towing procedures without fully understanding the correct tools and actions for all steps. Call for support if needed.

⚠ WARNING Failure to comply with the safety information in these instructions could result in serious injury or death.

- ⚠ Do not modify this product in any manner. Doing so could alter its integrity and lead to a loss of attachment between the trailer and the tow vehicle.
- ⚠ Adding Stealth hitch components to the chassis of any vehicle can be hazardous. There is potential for unexpected combustion of fuel, electric shock, burns, shifting or falling of unstable vehicle, damage to vehicle, injury from tool usage and many other hazards. This installation must be completed by someone who is aware of the hazards involved. This person must be knowledgeable of proper safety procedures for a vehicle modification of this nature, and for usage of the equipment required to perform the installation.
- ⚠ Without proper knowledge, towing can be a dangerous activity. Understand all the risks involved with towing before proceeding. For information on towing safety, see "**The Trailer Handbook: A Guide to Understanding Trailer and Towing Safety**" from the National Association of Trailer Manufacturers, www.NATM.com and your trailer and tow vehicle manufacturer's owner's manual.
- ⚠ Do not exceed tow or tongue rating of coupler, tow or tongue rating of hitch, or tow or weight ratings of tow vehicle or trailer. See vehicle and trailer manufacturer information for ratings. Exceeding these ratings may cause damage to towing components or loss of attachment between the trailer and vehicle.
- ⚠ While installation is being performed, check for signs of damage or excessive corrosion. Do not install hitch components over vehicle parts that are broken or have compromised structural integrity.
- ⚠ This product was designed to fit vehicles in their original, "as manufactured" condition. Compatibility with vehicles having replacement parts, or other modifications is not guaranteed. Inspect vehicle for modifications before installation of this product.
- ⚠ Some accessories, like the rack receiver, are not rated for towing. Do not use any accessories without proper knowledge of their use.
- ⚠ A visual inspection of the hitch should be performed before each use. Regularly check that all connections are secure, including those that secure the hitch to the vehicle. Check for cracks or damage to the hitch. Do not use the hitch if cracks or damage outside of normal wear is found. Using a hitch that has unsecure connections and/or cracks or damage could result in damage to the tow vehicle, trailer, towing components and loss of attachment between the tow vehicle and trailer.
- ⚠ Stealth hitches are not compatible with any weight distribution or sway control products. Adding additional products to the trailer or chassis which modifies the function of the Stealth hitch may cause hitch failure.

NOTICE: Installation of hitch requires removal of vehicle parts and interaction with vehicular electronics. Before installation, check the condition of body panels and note any locations where panels are not flush. Check the electronic functions of the vehicle, such as: headlights, taillights, turn signals, cameras, backup sensors, Parking Distance Controller (PDC), foot activated cargo access, etc. It is the responsibility of the installer to restore the fit and function of the vehicle.

IF INSTALLING HITCH INTO A BMW M3, START BY COMPLETING STEPS 1-5
IF INSTALLING HITCH INTO A BMW X1, START BY COMPLETING STEPS 6-12

M3 only GAIN ACCESS TO MOUNTING AREA

1. Open the vehicle cargo area. Remove the driver and passenger side panels by turning the knob counterclockwise.



8mm
SOCKET

2. Locate and remove (3) nuts securing the taillights. Disconnect light connector. Slide taillight rearward to remove.

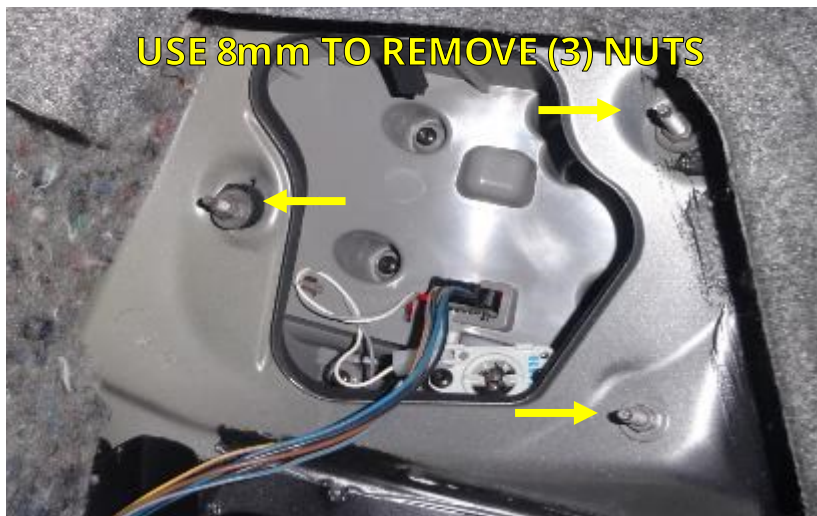

90 DEGREE
PICK

3. Locate and remove a plastic cover on each side of the hatch. Remove screw that was exposed with Torx.



T25 TORX

M3 only GAIN ACCESS TO MOUNTING AREA CONTINUED



8mm
SOCKET

4. Inside the rear wheel well, behind the tire, locate the (3) screws which are holding the wheel well liner (yellow arrows). Remove these screws and move the liner back toward the tire. Behind the liner locate (1) additional screw and remove it (green arrow).



8mm
SOCKET

5. Under the rear of the vehicle, remove (8) screws from the bottom of the fascia.

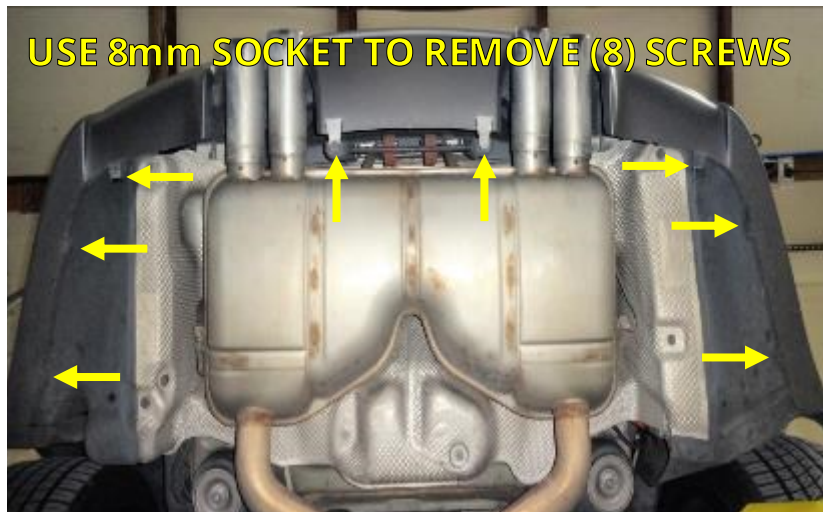

Skip to Step 13 to continue installation.

X1 only GAIN ACCESS TO MOUNTING AREA



8mm SOCKET



PLASTIC PRY TOOLS

6. Open the vehicle cargo area. Remove rear taillight panels from inside cargo area, with plastic pry tool. Use a socket to remove (3) nuts from behind the taillights.
7. Unplug the wiring harness and remove the taillights.



8mm SOCKET



PLASTIC PRY TOOLS



90 DEGREE PICK



T20 TORX

8. Remove (2) 8mm screws from inside rear wheel well liner.
9. Locate the rivets inside the rear wheel wells. Use a 90 degree pick or a pry tool to remove (3) most rearward plastic rivets. The rivets secure the wheel well trim to the vehicle.

NOTE: Replacement plastic rivets are supplied.

NOTE: Make sure not to damage the wheel well trim piece.



10. Partially remove the wheel well trim, starting at the bottom. Behind the rear wheel well trim is (1) screw holding the fascia. Pull trim away from vehicle to expose screw. Use a Torx to remove screw. Repeat Steps 9-11 on other side of vehicle.



8mm SOCKET

11. Under the rear of the vehicle, remove (9) screws from the bottom of the fascia.

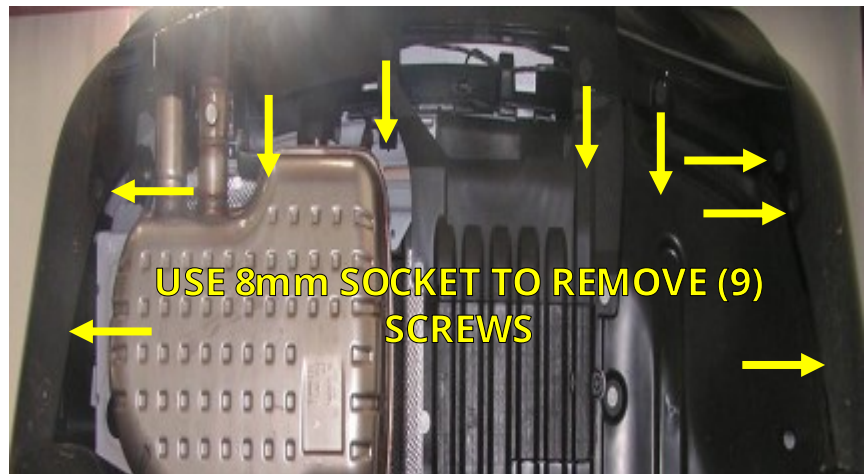

GAIN ACCESS TO MOUNTING AREA

12. This step requires a partner. The fascia is clipped to the vehicle body directly behind the wheel wells. Pull outward on the fascia to expose the first clip in the seam. With a plastic pry tool, push down on the exposed clip to disconnect. Continue to pull outward on the fascia and disconnect clips as they are exposed.



90 DEGREE PICK

13. Pull the fascia rearward enough to access the (4) PDC sensor plugs inside the fascia. Press down on the clips to unplug the PDC sensor plugs. In some cases a 90 degree pick tool will be needed to disconnect the sensor plug. Remove the fascia completely.

NOTICE: Carefully remove the fascia and place on a blanket or pad.



18mm DEEP WELL SOCKET

14. **X1 only** Disconnect the rubber exhaust hanger under the factory reinforcement beam.
15. Remove (6) nuts that secure the factory reinforcement beam with a socket. Save the nuts for hitch installation. Discard the factory reinforcement beam.



INSTALL STEALTH HITCH FRAME



18mm
DEEP WELL
SOCKET

16. Install the Stealth hitch frame onto the vehicle studs. Use the (6) saved nuts.

17. **X1 only** On the driver side bottom stud, put the exhaust rubber hanger bracket onto the hanger bracket supplied. Place the new hanger bracket onto the bottom stud and tighten the nut to secure the hanger bracket on top of the hitch profile.



18mm
DEEP WELL
SOCKET

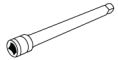

SOCKET
EXTENSION



TORQUE
WRENCH

18. Center the hitch frame. Torque all the nuts to 85 ft.-lbs.



MOUNT LATCH BLOCK



15/16"
SOCKET



15/16" OPEN
END WRENCH



TORQUE
WRENCH

19. Installation of the latch block varies depending on which kit you are installing.

- **Rack Receiver Kit:** Install the latch block with (2) 5/8"-11 x 5" bolts and (2) 5/8" nylock nuts. Tighten each bolt to 150 ft.-lbs.
- **Tow Kit:** Install the latch block and (2) chain hooks with (2) 5/8"-11 x 5" bolts and (2) 5/8" nylock nuts. Tighten each bolt to 150 ft.-lbs.

NOTICE: Keys are packaged within the latch block, remove keys and store in safe location.

RACK RECEIVER KIT INSTALL



TOW KIT INSTALL

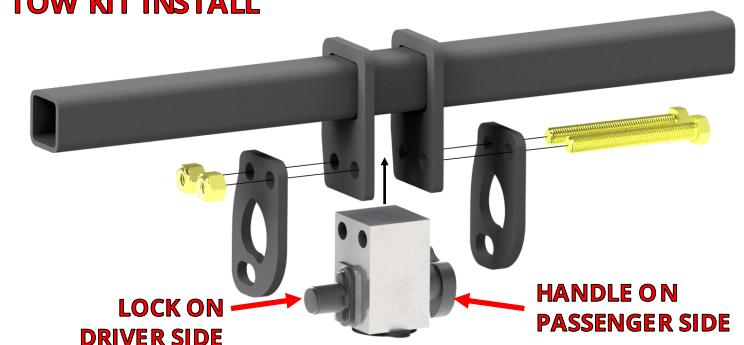

IF INSTALLING THE **X1** RACK RECEIVER KIT, SKIP TO STEP 36.
IF INSTALLING THE **M3** RACK RECEIVER KIT, SKIP TO STEP 38.
IF INSTALLING A TOW KIT, CONTINUE TO STEP 20.

INSTALL PASSIVE WIRING KIT

| # | DESCRIPTION | QTY |
|----|-------------------------|-----|
| 1 | 4-WAY CONNECTOR HARNESS | 1 |
| 2 | CONTROL MODULE | 1 |
| 3 | 4-WAY CONNECTOR COVER | 1 |
| 4 | CABLE TIE - 8" | 4 |
| 5 | CABLE TIE - 14" | 2 |
| 6 | MAGNETIC CABLE HOLDER | 1 |
| 7 | M8 SERRATED FLANGE NUT | 1 |
| 8 | FORK TERMINAL | 1 |
| 9 | ADHESIVE FOAM STRIP | 2 |
| 10 | BUTT CONNECTOR (RED) | 4 |
| 11 | CLAMP-ON CONNECTORS | 4 |



20. Locate the wiring kit box. Review the contents of the box against the list above to check for missing components. The passive wiring kit uses a control module to manage the functions of the trailer lighting. The module has an **"input"** side that receives power from the vehicle's battery and signals from the vehicle's taillights. The **"output"** side of the module delivers this information to the 4-way plug. The control module is connected to the vehicle's battery and taillight wiring as outlined in the next steps.

NOTICE: Do not allow electrical system to become disconnected from power or ground. Doing so may interrupt electrical systems.

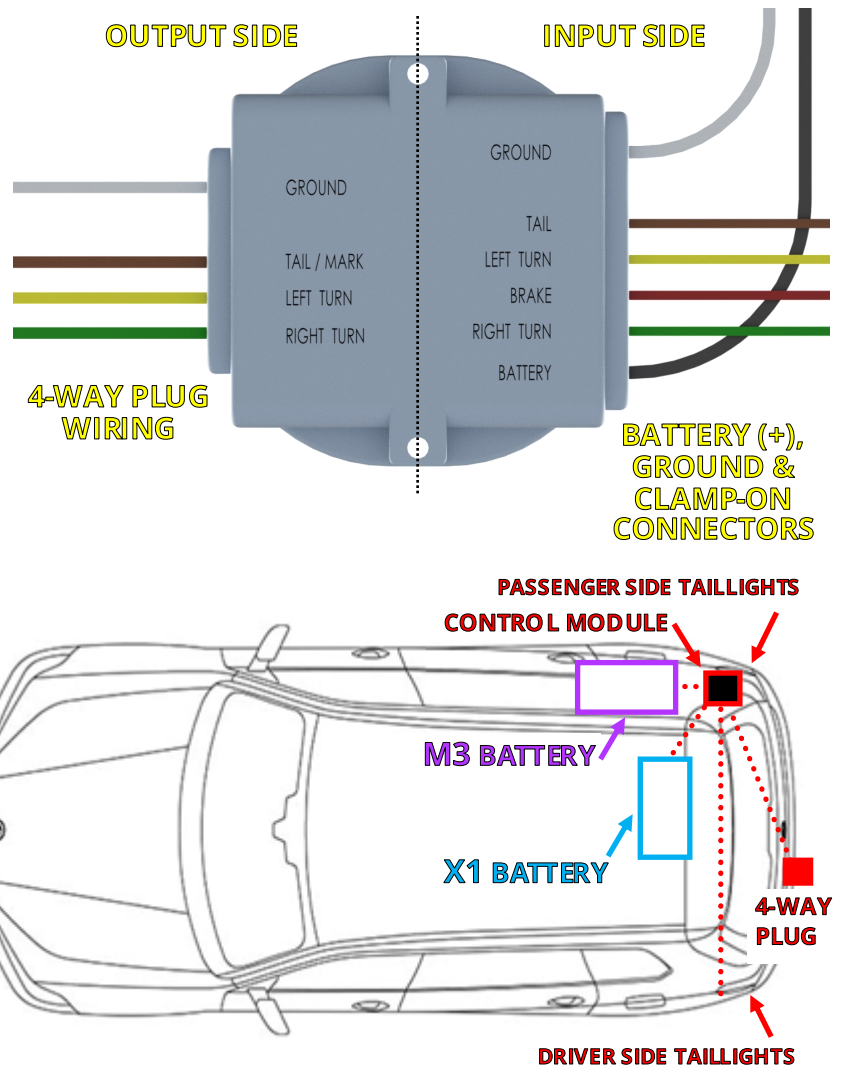

IF INSTALLING AN **X1**, CONTINUE TO STEP 21.
IF INSTALLING AN **M3**, SKIP TO STEP 25.

X1 only INSTALL WIRING KIT



T40 TORX



T20 TORX



90 DEGREE PICK

21. Remove (2) cargo hooks that are held by T40 Torx screws inside the rear wall (yellow arrows).

22. Remove (2) T20 Torx screws holding the threshold along the rear wall (green arrows). Lift up to remove the threshold. Remove the floor panel and divider tray from the cargo area.

USE T40 SOCKET TO REMOVE (2) CARGO HOOKS

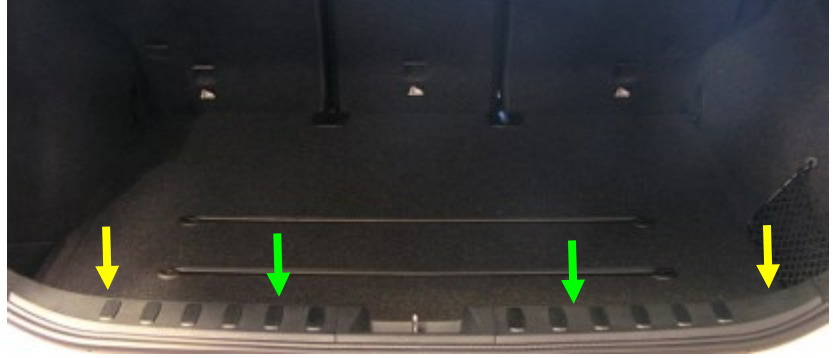

USE T20 SOCKET TO REMOVE (2) SCREWS

23. Locate indicated wiring harness grommet on the passenger side of the vehicle. Pull outlet wiring through the grommet to the exterior.



RAZOR KNIFE

24. Cut slit in grommet. Route the 4-way plug wires into the vehicle through the grommet hole. Insert 4-way plug wires into slit in grommet and reseal the grommet.



INSTALL WIRING KIT CONTINUED



SIDE CUTTERS

25. **M3 only** Locate indicated wiring harness grommet on the passenger side of the vehicle. Use side cutters to make a 3/8" hole in the grommet for wiring harness. Make sure to cut through grommet only and not to damage harness.

NOTICE: Confirm that there is nothing inside vehicle behind grommet that can be damaged.

26. Retrieve the 4-way connector harness from the wiring kit box. Route the 4-way plug wires through hole in grommet from outside of the vehicle to the inside of the vehicle.



STRIPPER/
CRIMPING
TOOL

27. On the passenger side of the vehicle, place the wiring harness control module in the cargo compartment area. Locate the tail of the 4-way connector wire and the output side wires of the control module. Attach each similar color wire to each other using a red butt connector and crimping tool.

NOTICE (OPTIONAL): The butt splice connectors are heat shrink connectors. Apply heat to waterproof the connectors after crimping.

RED BUTT CONNECTOR WITH HEAT-SHRINK ENDS

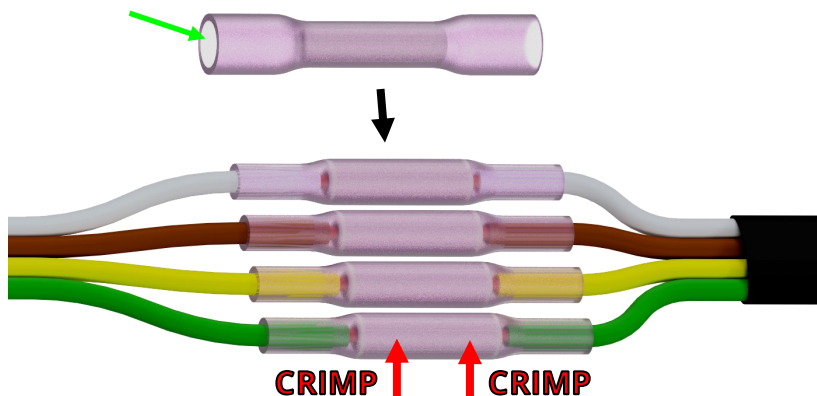

MATCH THE WIRE COLORS AND CRIMP EACH WIRE INTO THE SIDE OF EACH BUTT CONNECTOR. APPLY HEAT TO WATERPROOF AFTER CRIMPING

28. Secure harness to Stealth hitch frame with cable ties. Maintain an 18" loop from the cable tie to the 4-way plug. Add the magnetic cable holder and secure to the harness close to the 4-way plug, with a cable tie.

SECURE OUTPUT WIRES TO HITCH FRAME ADD MAGNETIC CABLE HOLDER HERE

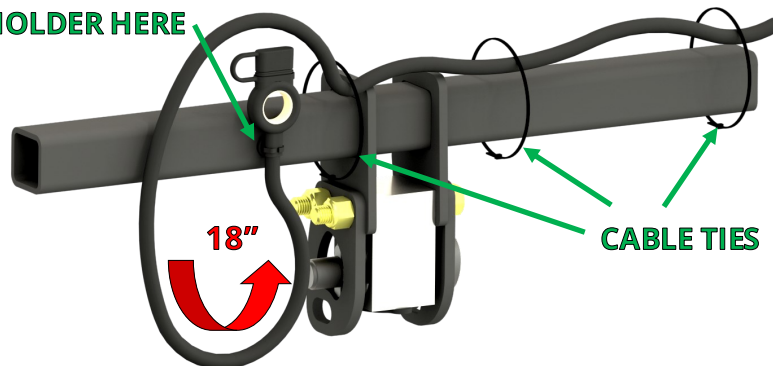

INSTALL WIRING KIT CONTINUED



PLIERS



MULTIMETER



RAZOR KNIFE

29. The wires on the input side of the module need to be attached to the vehicle wiring. In the passenger side of cargo area, locate the indicated part of the vehicle wiring harness. Remove enough tape to gain access to taillight wiring. Use clamp-on connectors to connect the harness wires to wires behind taillight. (As shown in reference table below.)

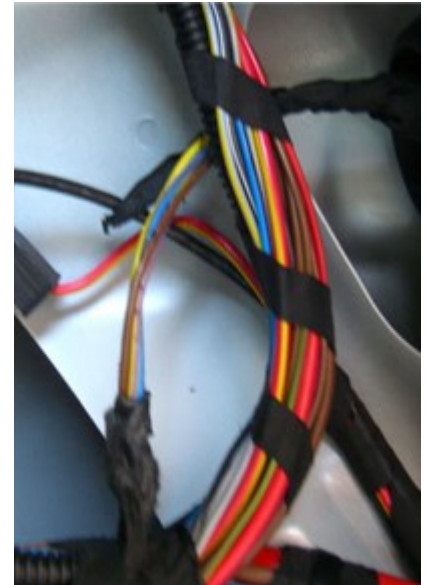
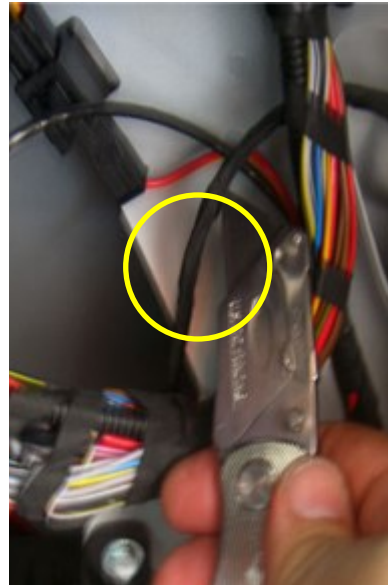

NOTE: Vehicles may have different wire colors than those shown. Verify circuits (wire colors) with multimeter.



PLIERS



MULTIMETER



RAZOR KNIFE



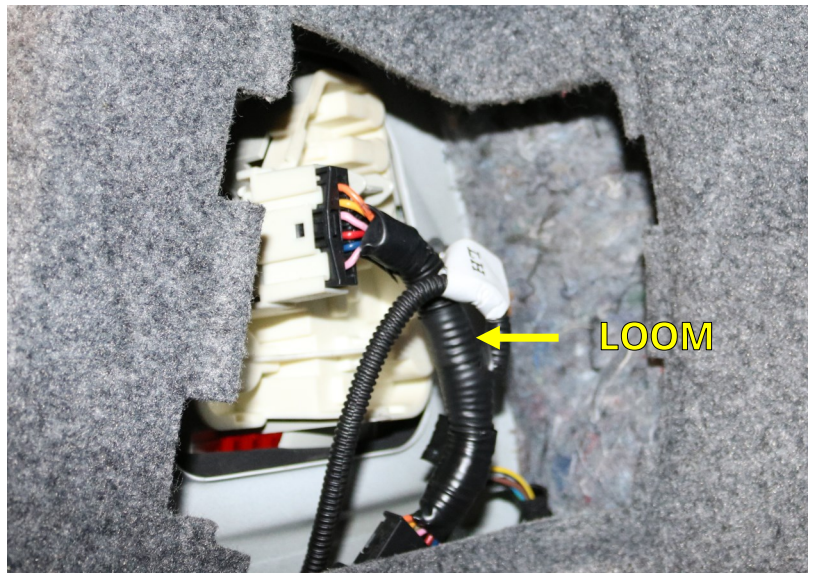







30. Using an existing vehicle wire harness as a guide, route the yellow input wire to the driver side of the vehicle. The threshold at the bottom of the trunk opening may need to be removed. Remove enough of the driver side wire loom to gain access to taillight wiring. Use a clamp-on connector to connect the yellow wire to left turn signal wire behind the taillight. (As shown in reference table below.)



CLAMP-ON CONNECTOR COLOR REFERENCE TABLE

SIGNAL INPUT WIRES

POWER & GROUND WIRES

| FUNCTION | HARNESS | VEHICLE | POWER & GROUND WIRES | | |
|------------|--|---|----------------------|---|-------------|
| LEFT TURN |  YELLOW |  BLUE/GREEN | <u>12V+ (POWER)</u> |  BLACK | BATTERY (+) |
| RIGHT TURN |  GREEN |  BLUE/BROWN | <u>GROUND</u> |  WHITE | BATTERY (-) |
| MARKER |  BROWN |  YELLOW/PURPLE | | | |
| BRAKE |  RED |  X1 - BLACK/BLUE  M3 - GREY/BLUE | | | |

NOTE: If two colors are listed, the first color is the dominant color.

INSTALL WIRING KIT CONTINUED



10mm
SOCKET

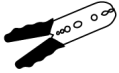

STRIPPER/
CRIMPING
TOOL



13mm
SOCKET
(M3 only)

31. **X1 & M3** If not already accessible, uncover the vehicle battery. Trim white ground wire so it will reach the negative battery terminal (-) without excess wire. Crimp supplied fork terminal to the ground wire with a crimping tool. Connect the ground wire to the negative battery terminal (-).

NOTICE: Loosen battery terminals just enough to install wiring, so vehicle wiring does not lose ground or power.

32. **X1 & M3** Locate the fuse holder supplied in the wiring kit box. Remove the fuse from fuse holder. Trim black power wire so it will reach the positive battery terminal (+) without excess. Crimp fuse holder lead to power wire. Connect fuse ring terminal to the positive battery terminal (+).



SILICONE

33. Reinstall the 20 Amp fuse in the fuse holder. Test the 4-way plug using a multimeter or connect the plug to a trailer and verify that the lights and brakes work correctly.
34. Use the provided adhesive foam strips to secure the control module to an inside body panel. Use silicone to waterproof the grommet.
35. Secure all wires and wiring components. Use the remaining cable ties to secure wiring so that it is not loose and will not interfere with replacement of the fascia. Wiring should not be visible once the vehicle is reassembled.

X1

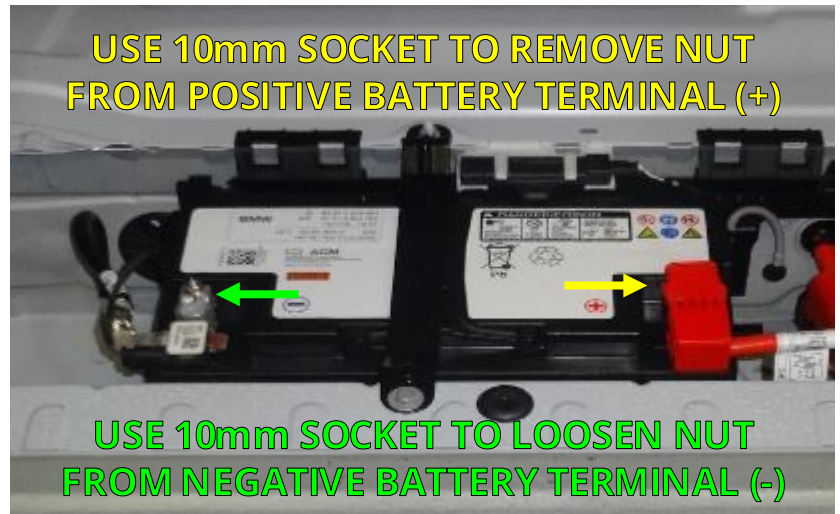

M3



CUT ACCESS TO LATCH BLOCK



DREMEL TOOL



FILE

36. **X1 only** Use a Dremel tool to trim bottom of fascia. Use a file to smooth out the cut.

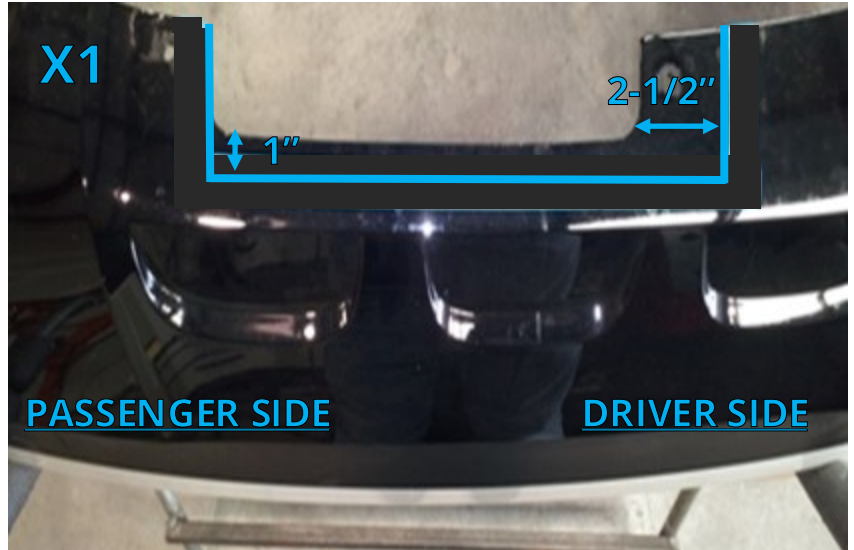

DREMEL TOOL



FILE

37. **X1 only** Trim the gravel guard, as shown. Use a file to smooth out the cut.

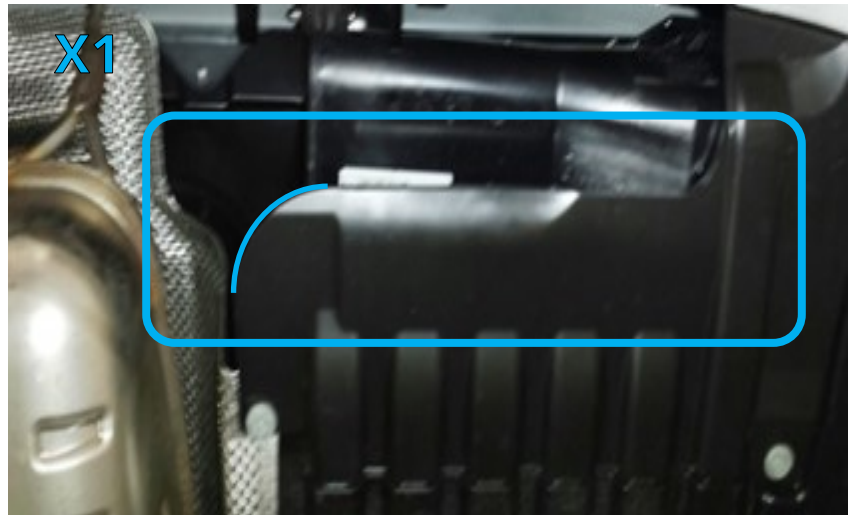

DREMEL TOOL



FILE

38. **M3 only** Cut out the gravel guard with Dremel tool, as shown. Use a file to smooth out the cut.

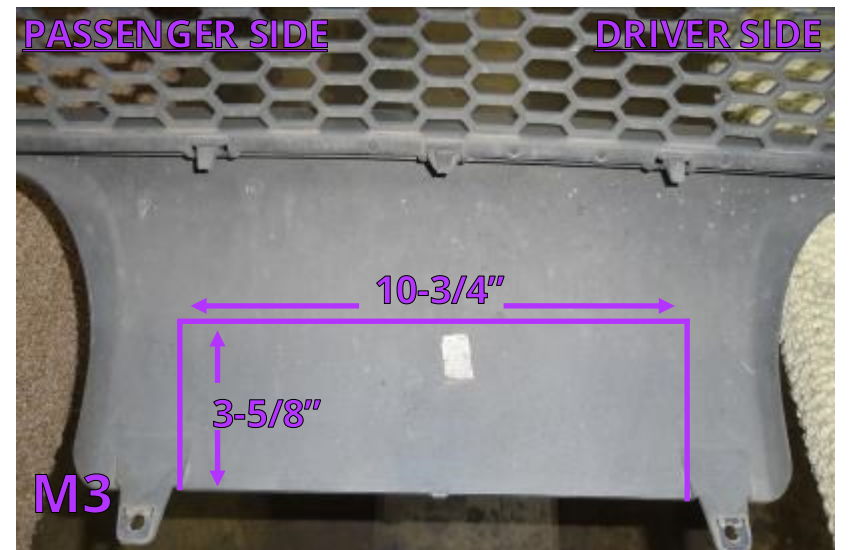

REINSTALL VEHICLE COMPONENTS

39. Reattach and secure the fascia, taillights, and other vehicle components in reverse order. Refer to Steps 1-13.
40. **X1 only** Use the (6) supplied rivets to replace the rivets in the wheel wells.

NOTICE: Remember to plug in the (4) sensor plugs in Step 13 before reinstalling the fascia.



FINAL VEHICLE EXAMINATION

41. Examine the body panels to ensure that they are in a pre-installation condition. Test the electronic functions of the vehicle. Correct any inconsistencies.
42. Ensure that hitch components work properly.
 - **Verify that the lock works correctly.** Push in the safety lock on the latch block then unlock with key. The lock should slide back out with the key when unlocked.
 - **Verify that each accessory can be installed correctly.** Use the following steps to install and remove each accessory that will be used with the hitch. (*Rack Receiver* and *Ball Mount* if purchased.)
 1. Prepare latching mechanism. Turn handle clockwise if needed.
 2. Firmly insert "post" of accessory into latch block until handle releases indicating that the accessory is latched.
 3. Push in the safety locking pin until it fully engages. The locking pin prevents the handle from turning when pushed in, and confirms that the block is securely latched onto the accessory. The safety locking pin will not depress if the accessory is not fully latched.
 4. Use key to release safety locking pin.
 5. While holding on to the accessory, rotate handle clockwise to release and remove the accessory.
 - **Verify that no part of the accessories come into contact with the body of the vehicle.**

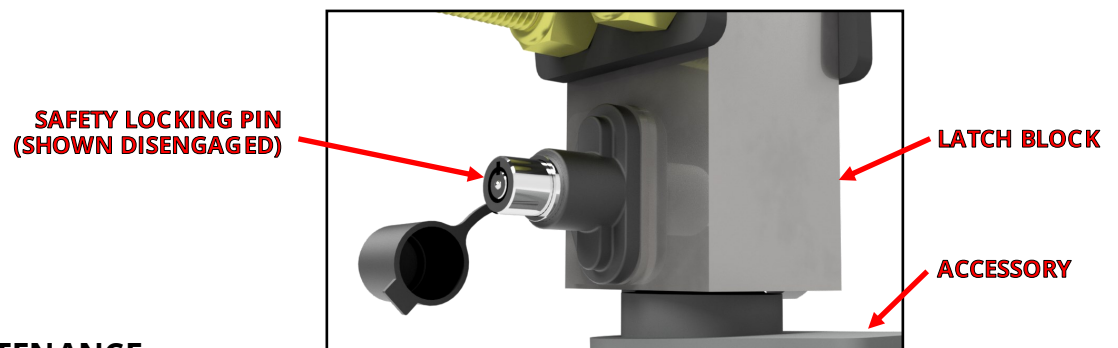

PRODUCT USE AND MAINTENANCE

NOTICE: *If the hitch is being installed by a professional, the installer is responsible for training the end user in the use and maintenance of the product.*

- **Accessory installation procedure:**
 1. Prepare latching mechanism. Turn handle clockwise if needed.
 2. Firmly insert "post" of accessory into latch block until handle spins counter-clockwise indicating that the accessory is latched.
 3. Always depress the safety locking pin and check that it has fully engaged.
- **Never use any accessory with the safety lock disengaged.** Until the safety locking pin is engaged, the handle is able to turn. A fully engaged safety locking pin is confirmation that the accessory is properly latched into the latch block.
- **Never use the rack receiver for towing.** The rack receiver accessory is only to be used with payload carrying products, such as bike racks or luggage racks.
- **Before each use, give the post of the accessory a light coating of lithium based grease.**
- **Before each use, inspect the hitch to ensure that all bolted connections are secure and that no cracks or damage are present.** Do not tow with the hitch if cracks or damage outside of normal wear is found.
- **Remove the Stealth accessories from the latch block after each use.** Do not leave accessories plugged in for extended periods of time.

SHR31012_(pn2120-31012-2) 05 22 2023